

STANDARD TVS ARRAYS

APPLICATIONS

- ✓ Low Frequency I/O Ports
- ✓ RS-232 & 423 Data Lines
- ✓ Power Bus Lines
- ✓ Monitoring & Industrial Data Ports
- ✓ Microprocessor Based Equipment

IEC COMPATIBILITY (EN61000-4)

- ✓ 61000-4-2 (ESD): Air - 15kV, Contact - 8kV
- ✓ 61000-4-4 (EFT): 40A - 5/50ns
- ✓ 61000-4-5 (Surge): 24A, 8/20 μ s - Level 2(Line-Gnd) & Level 3(Line-Line)

FEATURES

- ✓ **ESD PROTECTION > 40 kilovolts**
- ✓ 800 Watts Peak Pulse Power Dissipation per Line (8/20 μ s)
- ✓ Protects 8 to 12 Lines
- ✓ Unidirectional & Bidirectional Configurations

MECHANICAL CHARACTERISTICS

- ✓ Molded Plastic Dual-in-Line 16 Pin Package
- ✓ Weight 1.2 grams (Approximate)
- ✓ Flammability Rating UL 94V-0
- ✓ Device Marking: Logo, Part Number & Pin One Defined By DOT on Top of Package

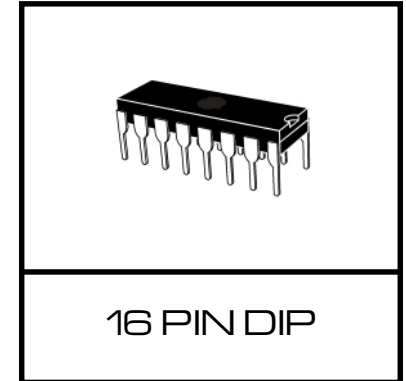

CIRCUIT DIAGRAMS

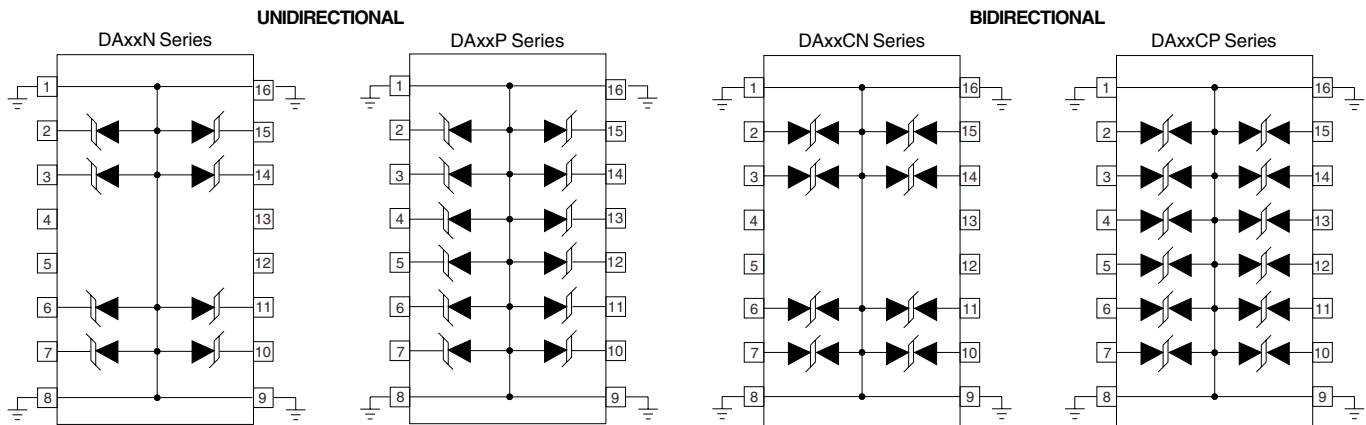

DEVICE CHARACTERISTICS

MAXIMUM RATINGS @ 25°C Unless Otherwise Specified			
PARAMETER	SYMBOL	VALUE	UNITS
Peak Pulse Power ($t_p = 8/20\mu s$) - See Figure 1	P_{PP}	800	Watts
Operating Temperature	T_J	-55°C to 150°C	°C
Storage Temperature	T_{STG}	-55°C to 150°C	°C
Forward Surge Rating (1/20 seconds @ 25°C)	V_F	10	Amps

ELECTRICAL CHARACTERISTICS PER LINE @ 25°C Unless Otherwise Specified						
PART NUMBER (See Notes 1 & 2)	RATED STAND-OFF VOLTAGE V_{WM} VOLTS	MINIMUM BREAKDOWN VOLTAGE @ 1mA $V_{(BR)}$ VOLTS	MAXIMUM CLAMPING VOLTAGE (See Fig. 2) @ $I_p = 1A$ V_C VOLTS	MAXIMUM CLAMPING VOLTAGE (See Fig. 2) @ 8/20 μs $V_C @ I_{PP}$	MAXIMUM LEAKAGE CURRENT @ V_{WM} I_D μA	TYPICAL CAPACITANCE 0V @ 1 MHz C pF
DA05N	5.0	6.0	12.5	24.6V @ 45A	200	880
DA12N	12.0	13.3	26.0	32.9V @ 34A	2	440
DA15N	15.0	16.7	33.0	37.7V @ 27A	2	400
DA24N	24.0	26.7	52.1	48.5V @ 22A	2	275
DA05P	5.0	6.0	12.5	24.6V @ 45A	200	880
DA12P	12.0	13.3	26.0	32.9V @ 34A	2	440
DA15P	15.0	16.7	33.0	37.7V @ 27A	2	400
DA24P	24.0	26.7	52.1	48.5V @ 22A	2	275
DA05CN	5.0	6.0	12.5	24.6V @ 45A	200	500
DA12CN	12.0	13.3	26.0	32.9V @ 34A	2	385
DA15CN	15.0	16.7	33.0	37.7V @ 27A	2	300
DA24CN	24.0	26.7	52.1	48.5V @ 22A	2	200
DA05CP	5.0	6.0	12.5	24.6V @ 45A	200	500
DA12CP	12.0	13.3	26.0	32.9V @ 34A	2	385
DA15CP	15.0	16.7	33.0	37.7V @ 27A	2	300
DA24CP	24.0	26.7	52.1	48.5V @ 22A	2	200

Note 1: Unidirectional Only: $V_F = 1.5$ Volts @ 10A, 300 μs (square wave).

Note 2: The "C" suffix specifies a bidirectional device, such as DA05CN or DA12CP.

GRAPHS

FIGURE 1
PEAK PULSE POWER VS PULSE TIME

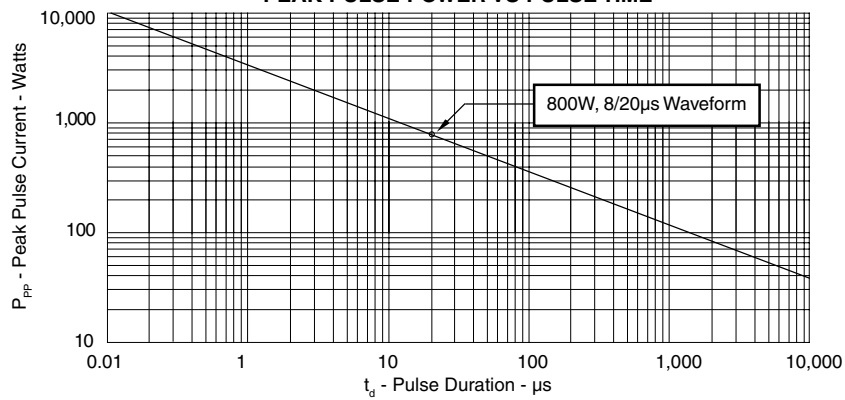

FIGURE 2
PULSE WAVE FORM

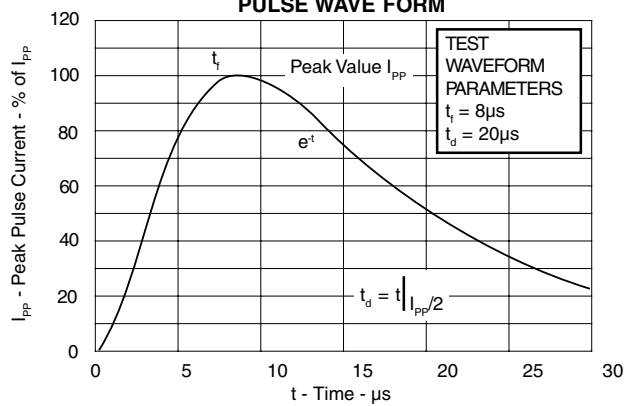
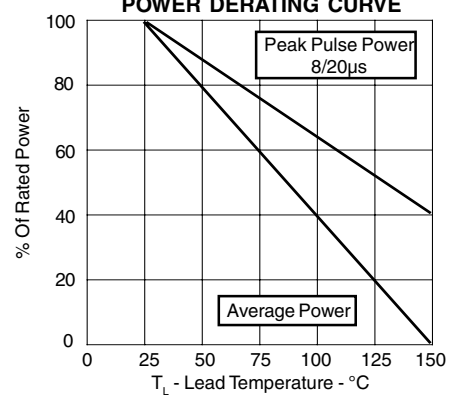
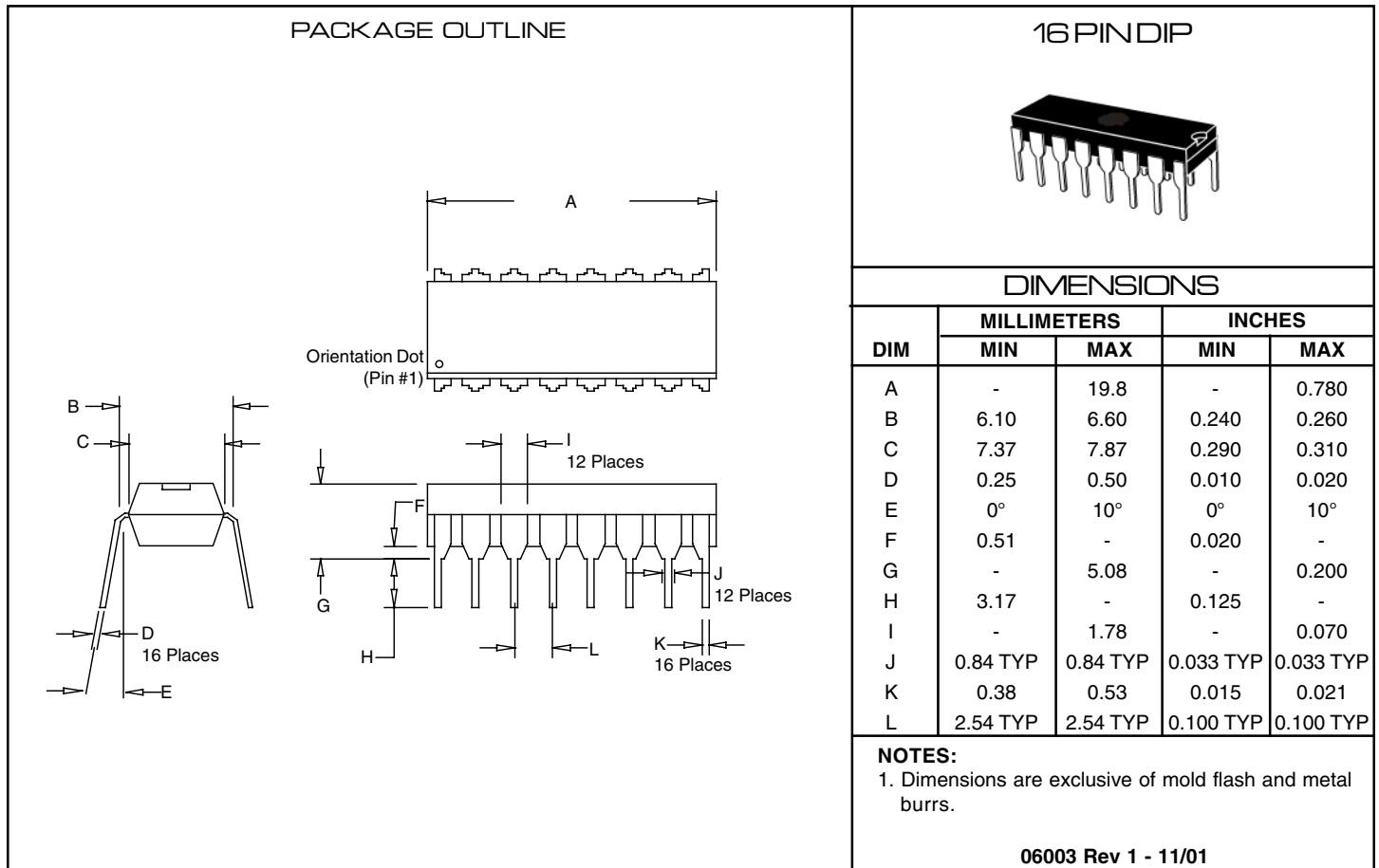

FIGURE 3
POWER DERATING CURVE



DA05N thru DA24CP

PACKAGE OUTLINE & DIMENSIONS



ProTek Devices
2929 South Fair Lane, Tempe, AZ 85282
Tel: 602-431-8101 Fax: 602-431-2288
E-Mail: sales@protekdevices.com
Web Site: www.protekdevices.com

COPYRIGHT © ProTek Devices 2001

SPECIFICATIONS: ProTek reserves the right to change the electrical and or mechanical characteristics described herein without notice (except JEDEC).

DESIGN CHANGES: ProTek reserves the right to discontinue product lines without notice, and that the final judgement concerning selection and specifications is the buyer's and that in furnishing engineering and technical assistance, ProTek assumes no responsibility with respect to the selection or specifications of such products.