

To all our customers

Regarding the change of names mentioned in the document, such as Mitsubishi Electric and Mitsubishi XX, to Renesas Technology Corp.

The semiconductor operations of Hitachi and Mitsubishi Electric were transferred to Renesas Technology Corporation on April 1st 2003. These operations include microcomputer, logic, analog and discrete devices, and memory chips other than DRAMs (flash memory, SRAMs etc.) Accordingly, although Mitsubishi Electric, Mitsubishi Electric Corporation, Mitsubishi Semiconductors, and other Mitsubishi brand names are mentioned in the document, these names have in fact all been changed to Renesas Technology Corp. Thank you for your understanding. Except for our corporate trademark, logo and corporate statement, no changes whatsoever have been made to the contents of the document, and these changes do not constitute any alteration to the contents of the document itself.

Note : Mitsubishi Electric will continue the business operations of high frequency & optical devices and power devices.

Renesas Technology Corp.
Customer Support Dept.
April 1, 2003

M62501P,FP

PWM IC for the synchronized deflection system control

GENERAL DESCRIPTION

The M62501P/FP is a controller for a deflection system of CRT display monitors. It performs a stable PWM control over a wide fluctuation of external signals, thanks to the built-in trigger mode oscillator. The IC is suitable for an application to a high voltage drive of monitors because of its following circuits and functions;

- low voltage malfunction protection circuit,
- over or under voltage protection circuit for a control line,
- soft-start function.

It is also applicable to a horizontal output correction.

FEATURES

- PWM output synchronized with external signals
- Wide pulse width modulation control frequency
15kHz to 150kHz
- Soft start function
- The under voltage output malfunction protection circuit
start $V_{cc} > 9V$ stop $V_{cc} < 6V$
- Built-in over voltage protection (OVP) and under voltage protection (UVP) control

APPLICATION

- CRT display monitor

PIN CONFIGURATION(TOP VIEW)

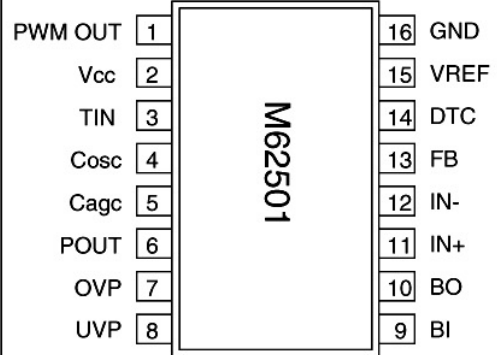

outline P: 16P4
FP: 16P2S

BLOCK DIAGRAM

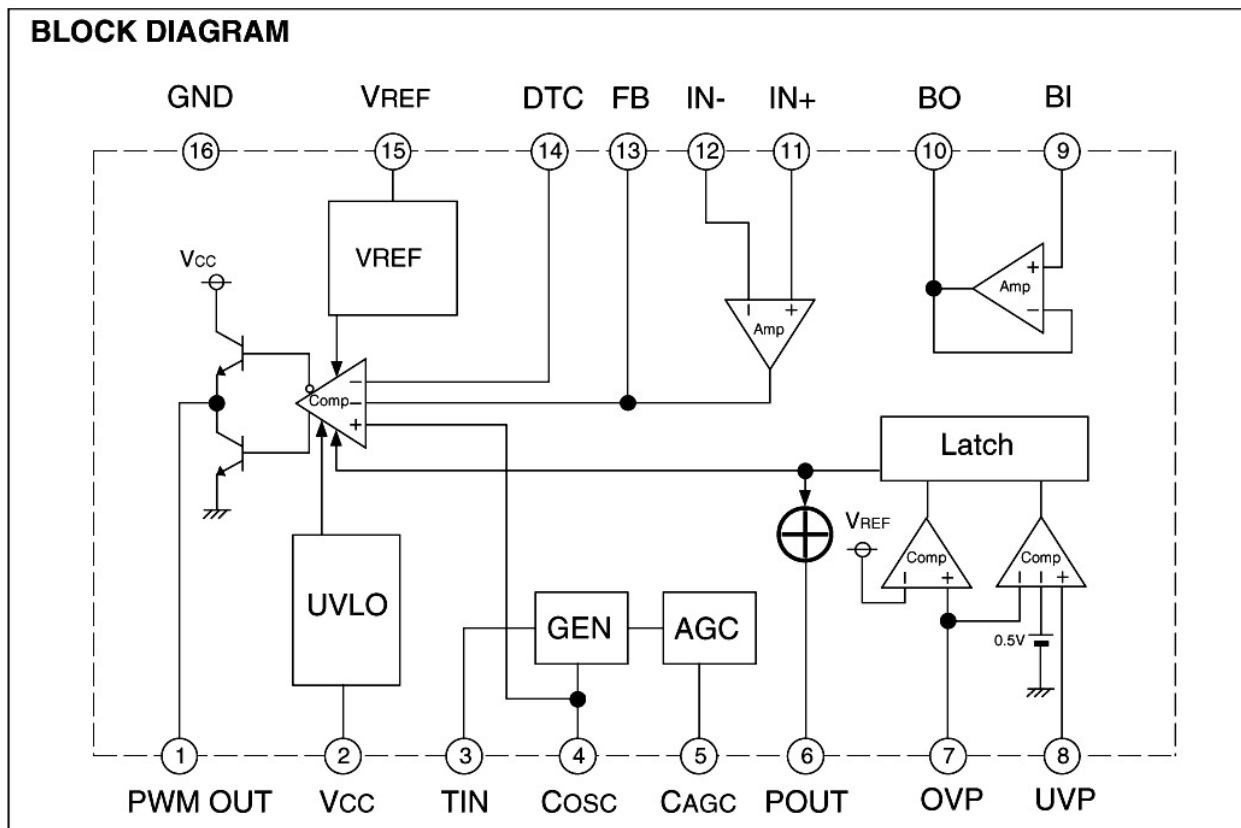

M62501P,FP

PWM IC for the synchronized deflection system control

Terminal Number and The facility

PIN No.	Symbol	Functional Description
1	PWM OUT	PWM output
2	VCC	Power supply
3	TIN	Trigger input
4	COSC	Setting oscillating frequency
5	CAGC	AGC setting
6	P.OUT	Error signal output
7	OVP	Input of over voltage protection
8	UVP	Input of under voltage protection
9	BI	Positive input of buffer Amp.
10	BO	Output of buffer Amp.
11	IN+	Positive input of Op-Amp.
12	IN-	Negative input of Op-Amp.
13	FB	Output of Op-Amp.
14	DTC	Dead time control (Soft start function)
15	VREF	Output of reference voltage (5V)
16	GND	Ground

ABSOLUTE MAXIMUM RATINGS (Ta=25°C,unless otherwise noted)

Symbol	Parameter	Conditions	Ratings	Unit
VCC	Supply voltage		15	V
VOUT	Output voltage		15	V
IOUT	Output current		±100	mA
VICM	Error Amplifier input common mode voltage		-0.3 ~ VCC	V
VID	Error Amplifier differential input voltage		VCC	V
Pd	Power dissipation		P	mW
			1200	
Kθ	Thermal derating	Ta ≥ 25°C	P	mW/°C
			9.6	
Topr	Operating temperature		-20 ~ +75	°C
Tstg	Storage Temperature		-40 ~ +150	°C

M62501P,FP

PWM IC for the synchronized deflection system control

ELECTRICAL CHARACTERISTICS (Vcc = 12V, TIN = 40kHz, Ta = 25°C, unless otherwise noted)

Block	Symbol	Parameter	Test conditions	Limits			Unit
				Min	Typ	Max	
All Device	Vcc	Range of power supply		VCC OFF		14	V
	Icc	Circuit current	Output off mode		20		mA
Reference voltage section	VREF	Reference voltage	IREF=-5mA	4.80	5.00	5.20	V
	Reg-in	Input regulation	Vcc=7 ~ 14V IREF=-5mA		1.0	10	mV
	Reg-L	Load regulation	IREF=0 ~ -5mA		2.0	20	mV
	TCVREF	Reference voltage thermal coefficient			0.01		% / °C
	IREF MAX	Maximum reference current			-30		mA
	Is	Short-circuit current			-30		mA
Error Amp.	Vio	Input offset voltage				7	mV
	Iib	Input bias current		-100			nA
	Iio	Input offset current		-100		100	nA
	VICM	Common mode input voltage range		-0.3		VCC-2	V
	AV	Open loop transmission gain		70	110		dB
	SR	Slew rate			4		V / μs
	VOR	Output voltage range		0.3		VREF-1.5	V
	Isink	Output sink current		10			mA
	Isource	Output source current				-10	mA
Buffer Amp.	Ib	Input bias current		-20			nA
	SR	Slew rate			4		V / μs
	VOR	Output voltage		0.3		Vcc-2.5	V
	Isink	Output sink current		2			mA
	Isource	Output source current				-10	mA
Oscillator	fOSC	Oscillation frequency		15		150	kHz
	VOSC H	The oscillator waveform bound voltage			3.5		V
	VOSC L	The oscillator waveform lower limit voltage			1.5		V
	VTIN H	High level of TIN		2.5		VCC	V
	VTIN L	Low level of TIN				1.0	V
PWM output section	Vsat L	Output saturation voltage L	IO=100mA		0.7	1.4	V
	Vsat H	Output saturation voltage H	IO=-100mA	9.5	10.5		V
UVLO section	VTH ON	ON threshold voltage		8.0	9.0	10.0	V
	VTH OFF	OFF threshold voltage		5.4	6.0	6.6	V
OVP section	VTH OVP	OVP terminal threshold voltage		4.75	5.00	5.25	V
	IIN OVP	OVP terminal input current				1.0	μA
UVP section	VUVPO	Input offset voltage				7	mV
	IIN UVP	UVP terminal input current				1.0	μA
P.OUT section	Vsat	Output saturation voltage	IPO=10mA			0.4	V
	IL	Output leakage current	VPO=12V			1.0	μA

M62501P,FP

PWM IC for the synchronized deflection system control

Terminal functional description and equivalent circuit

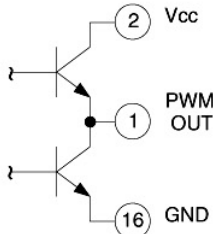
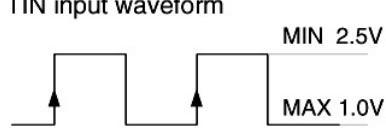
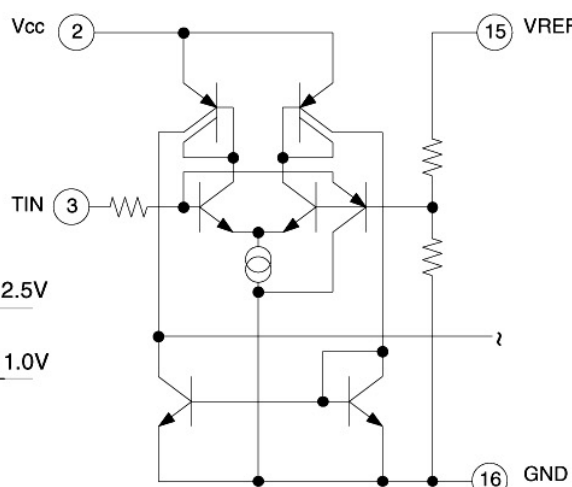
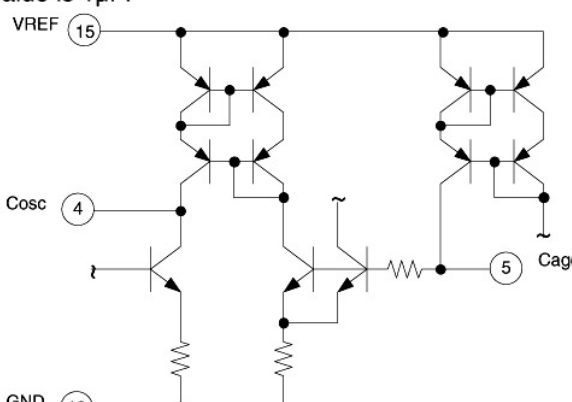
Terminal No.	Symbol	Function and terminal circumscription circuitry
1	PWM OUT	<ul style="list-style-type: none"> •PWM output terminal •The PWM output synchronized with the TIN input. •Output "H" level = 10.5V typ (The output load current:-100mA, Vcc=12V) •Output "L" level = 0.7V Typ (The output load current:+100mA, Vcc=12V) 
2	Vcc	Power supply terminal
3	TIN	<ul style="list-style-type: none"> •Trigger input terminal •Frequency range 15kHz ~ 150kHz •It takes in a start edge. <p>TIN input waveform</p>  
4	Cosc	<ul style="list-style-type: none"> •Cosc terminal •It generates a saw wave by connecting capacitor between 4pin and GND. •Recommended capacitor value is 1000pF.
5	Cagc	<ul style="list-style-type: none"> •Cagc terminal •It sets up sensitivity of AGC by connecting capacitor between 5pin and GND. •Recommended capacitor value is 1μF. 

M62501P,FP

PWM IC for the synchronized deflection system control

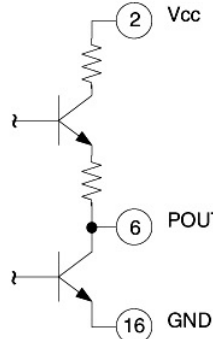
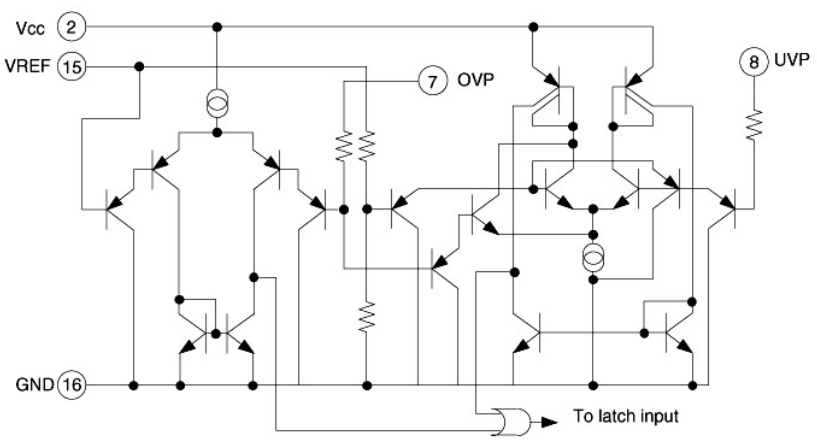
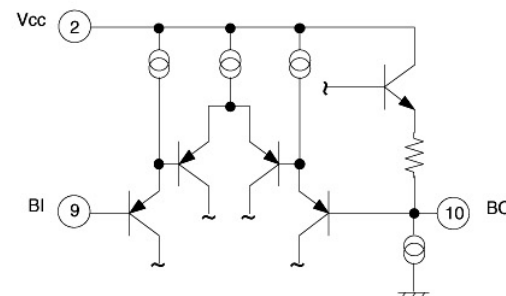
Terminal No.	Symbol	Function and terminal circumscription circuitry
6	POUT	<ul style="list-style-type: none"> •The abnormal state detection output terminal •The output becomes "H" from "L" when an abnormality is detected in the OVP or UVP terminal. Then the PWM output terminal becomes "H" settlement, too. •Do OFF of power supply (Vcc) to remove latch of abnormal state. •In abnormal state detection ; Output "H" level = 10.5V typ (The output load current : no-load, Vcc=12V) Output "L" level = 1.5V typ (The output load current : -1mA, Vcc=12V) •In normal state ; Output "L" level = 0.4V typ (The output load current : +10mA, Vcc=12V) 
7 8	OVP UVP	<ul style="list-style-type: none"> •Over voltage protection of the control line (OVP) •Setting terminal voltage ; $GND \leq VOVP < VREF$ •Under voltage protection of the control line (UVP) •Setting terminal voltage ; $GND \leq VUVP < VOVP$  <p>Note:It is connected to GND when the abnormal detection terminal is not used.</p>
9 10	BI BO	<ul style="list-style-type: none"> •The input terminal of a buffer Amp. (BI) •The output terminal of a buffer Amp. (BO) 

M62501P,FP

PWM IC for the synchronized deflection system control

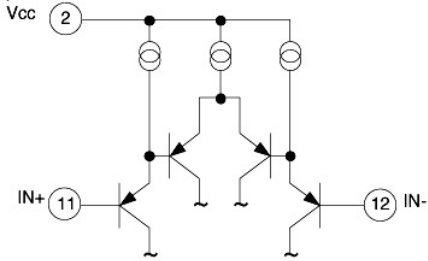
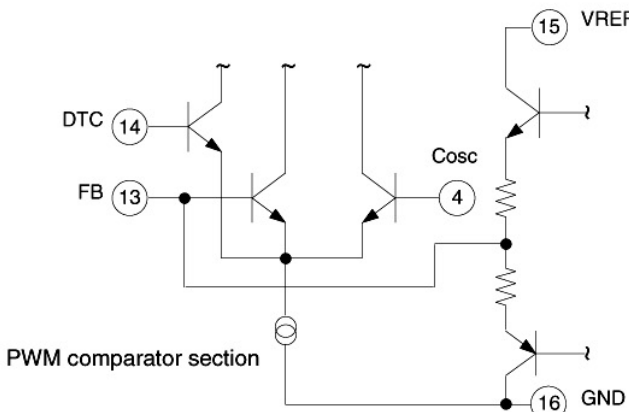
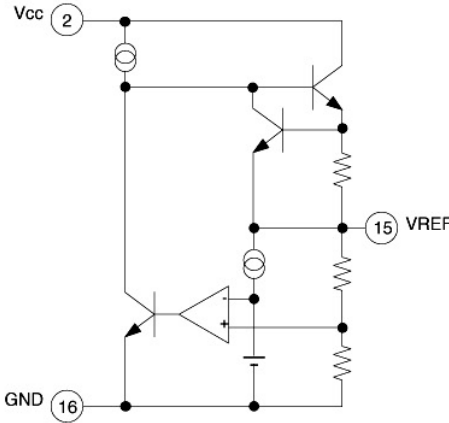
Terminal No.	Symbol	Function and terminal circumscription circuitry
11	IN+	<ul style="list-style-type: none"> •Positive input terminal of an Op-Amp. (IN+) •Negative input terminal of an Op-Amp. (IN-) 
13	FB	<ul style="list-style-type: none"> •Output terminal of an Op-Amp. (FB) •Dead time control terminal (DTC) •It can do soft start during power-on under keeping time constant.
14	DTC	
15	VREF	<ul style="list-style-type: none"> •Reference voltage terminal •5V output voltage (The terminal can begin to take outside connected load 5mA.) 
16	GND	<ul style="list-style-type: none"> •Ground terminal

M62501P,FP

PWM IC for the synchronized deflection system control

M62501 APPLICATION

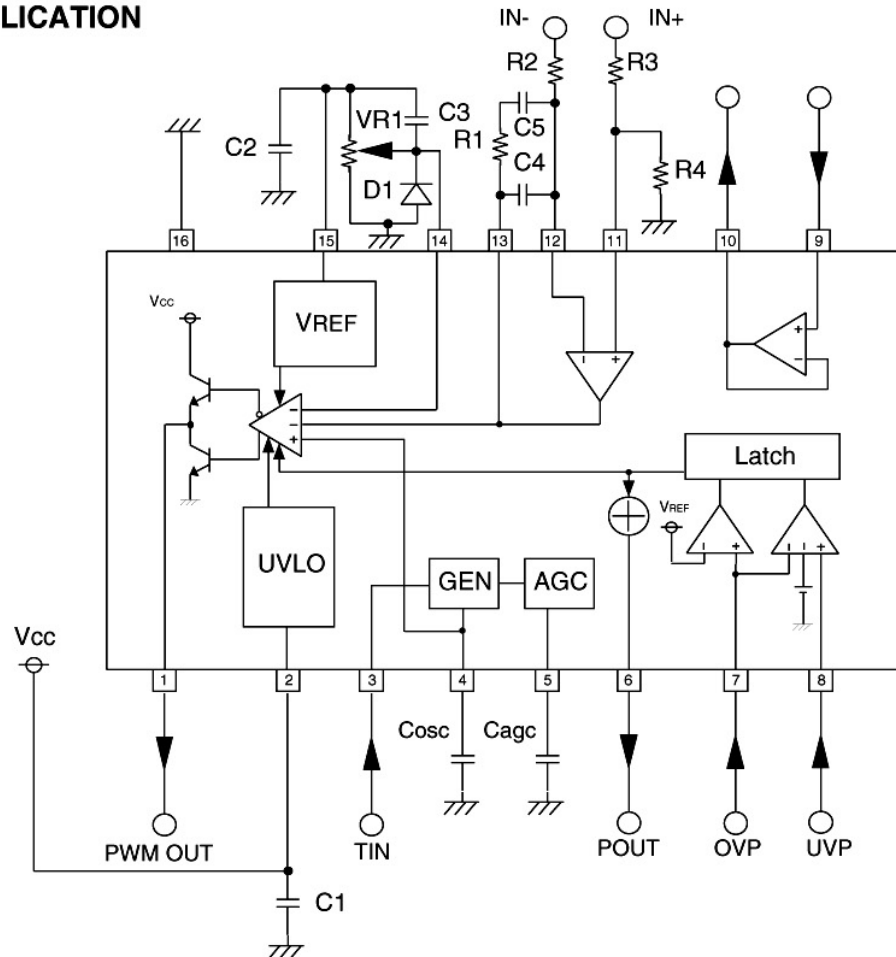

- C1,C2 Stabilization capacitors of Vcc and VREF.
- VR1 It is decided considering a load capacity of VREF.
(A load capacity is approximately 5mA.)
Recommended value is around 10kΩ.
- C3,D1 They are for the soft start function. A time constant is decided considering VR1.
- Cagc This capacitor is for stabilization of AGC. A larger capacitor improves a stability of the system, however a system response is degraded.
Recommended value is around 1μF.
- Cosc This capacitor is for a saw wave generation. Recommended value is around 1000pF.
- R1,R2,R3,R4 They are for a gain setting of the error Amp. R2 should be several kΩ to dozens of kΩ to set a voltage gain 20dB to 40 dB at f = 1kHz, so that the feed back loop is stable.
When the voltage gain is too low, it causes jitter.
Recommended values of C4, C5 and R1 are ;
C4 = dozens of pF to several hundreds pF
C5 = several thousands pF to tens of thousands pF
R1 = dozens of kΩ to several hundreds kΩ.

*Annotation:Connect 7pin and 8pin terminal to GND when don't use under voltage protection (UVP).

M62501P,FP

PWM IC for the synchronized deflection system control

EXAMPLE OF APPLICATION CIRCUIT

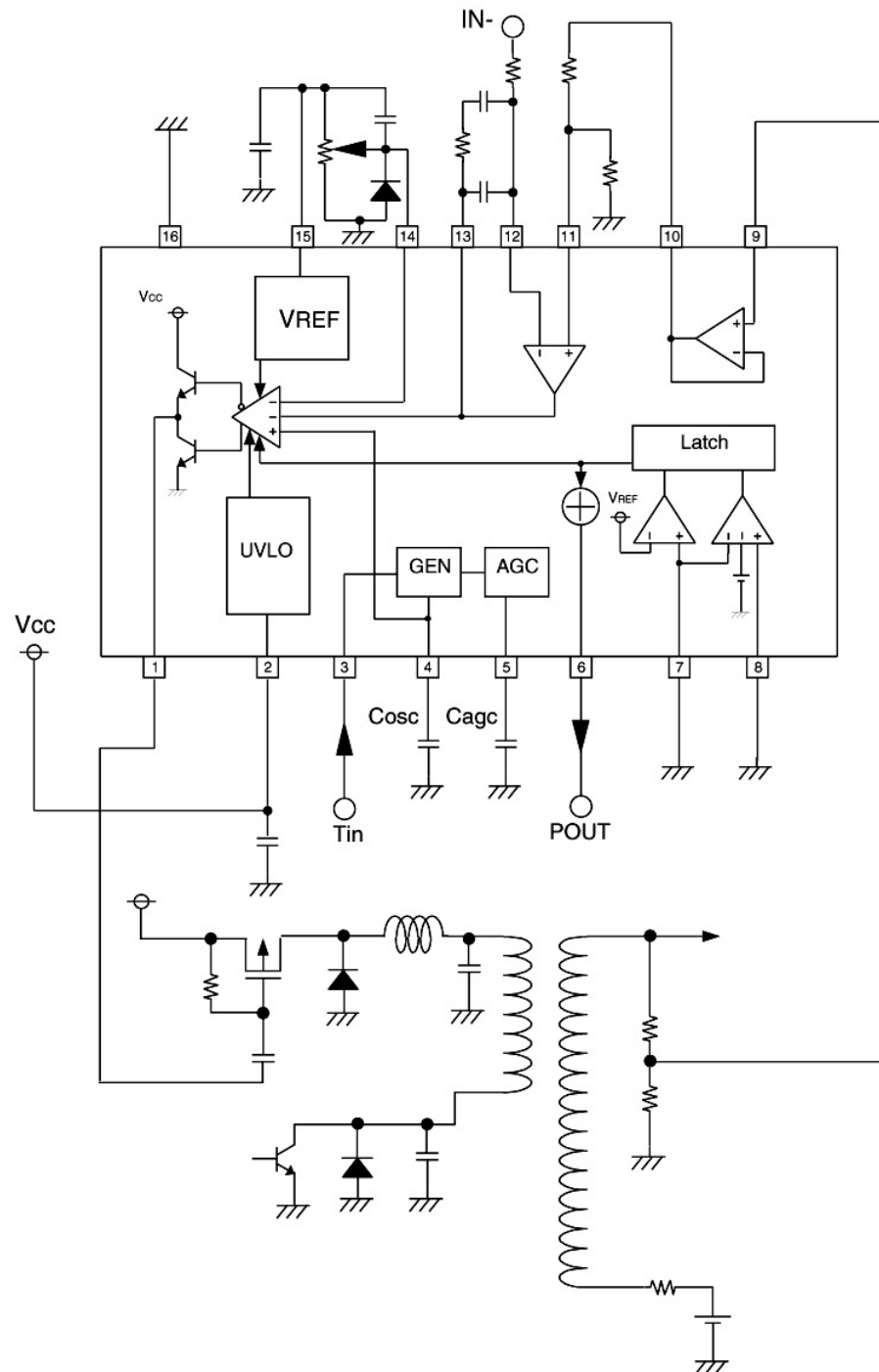

M62501P,FP

PWM IC for the synchronized deflection system control

Timing chart

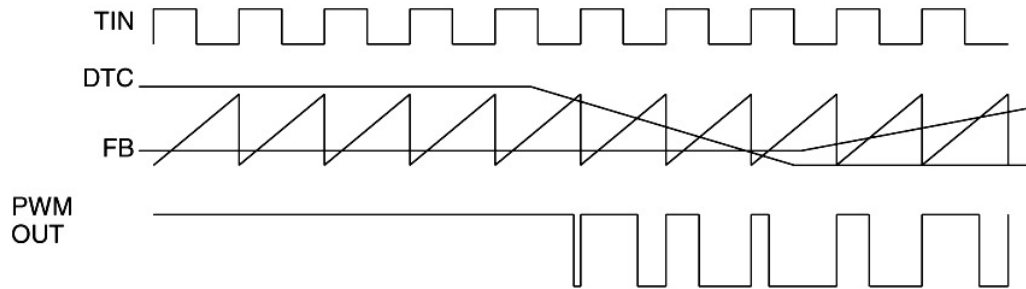

- PWM OUT ON Duty is fixed in the voltage of higher one between DTC terminal and FB terminal voltage.

- Waveform at "H" was taken from "L", and having put TIN up (PWM output is fixed in "H", too when fix TIN terminal in "H".)

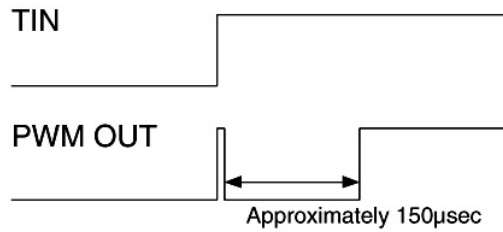

- Waveform at "L" was taken from "H", and having put TIN up (PWM output is fixed in "L", too when fix TIN terminal in "L".)

