

μP Compatible 8-Bit A/D Converter with 8-Channel Multiplexer

GENERAL DESCRIPTION

The ML2258 combines an 8-bit A/D converter, 8-channel analog multiplexer, and a microprocessor compatible 8-bit parallel interface and control logic in a single monolithic device.

Easy interface to microprocessors is provided by the latched and decoded multiplexer address inputs and latched three-state outputs.

The device is suitable for a wide range of applications from process and machine control to consumer, automotive, and telecommunication applications.

The ML2258 is an enhanced, pin-compatible, second source for the industry standard ADC0808/ADC0809. The ML2258 enhancements are faster conversion time, true sample and hold function, superior power supply rejection, wider reference range, and a double buffered data bus as well as faster digital timing. All parameters are guaranteed over temperature with a power supply voltage of $5V \pm 10\%$.

FEATURES

- Conversion time 6.6μs
- Total unadjusted error $\pm 1/2\text{LSB}$ or $\pm 1\text{LSB}$
- No missing codes
- Sample and hold 390ns acquisition
- Capable of digitizing a 5V, 50kHz sine wave
- 8-input multiplexer
- 0V to 5V analog input range with single 5V power supply
- Operates ratiometrically or with up to 5V voltage reference
- No zero-or full-scale adjust required
- Analog input protection 25mA per input min
- Low power dissipation 3mA max
- TTL and CMOS compatible digital inputs and outputs
- Standard 28-pin DIP or surface mount PCC
- Superior pin compatible replacement for ADC0808 and ADC0809

BLOCK DIAGRAM

* Some Packages Are End Of Life As Of August 1, 2000

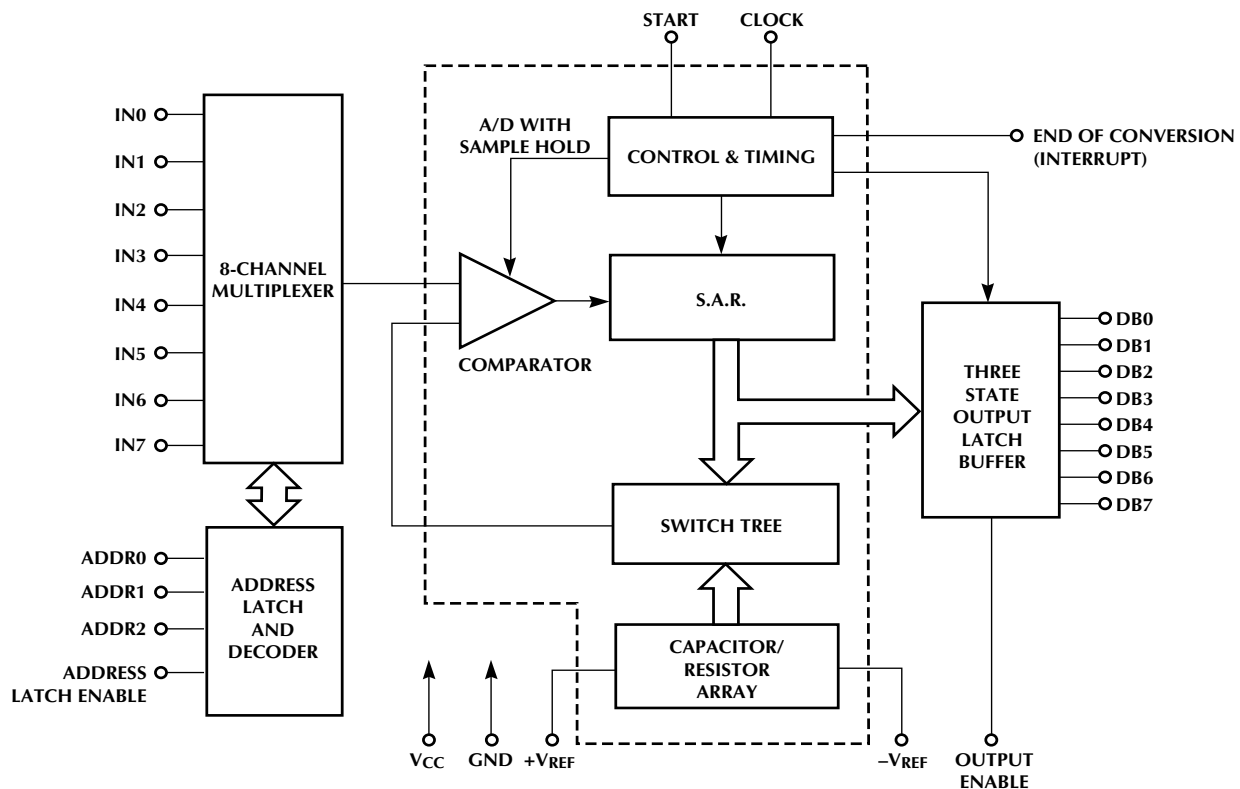

PIN CONFIGURATION

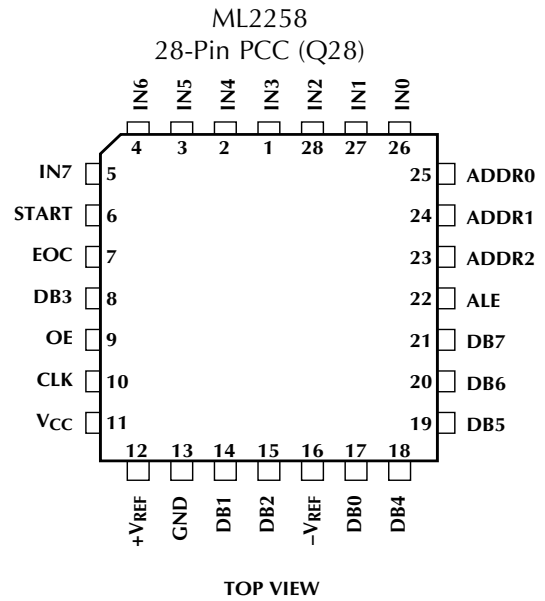
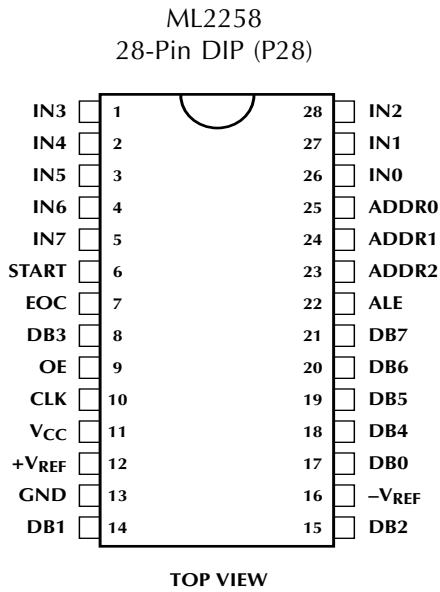

PIN DESCRIPTION

PIN#	NAME	FUNCTION	PIN#	NAME	FUNCTION
1	IN3	Analog input 3.	13	GND	Ground. 0V, all analog and digital inputs or outputs are reference to this point.
2	IN4	Analog input 4.	14	DB1	Data output 1.
3	IN5	Analog input 5.	15	DB2	Data output 2.
4	IN6	Analog input 6.	16	-V _{REF}	Negative reference voltage.
5	IN7	Analog input 7.	17	DB0	Data output 0.
6	START	Start of conversion. Active high digital input pulse initiates conversion.	18	DB4	Data output 4.
7	EOC	End of conversion. This output goes low after a START pulse occurs, stays low for the entire A/D conversion, and goes high after conversion is completed. Data on DB0–DB7 is valid on rising edge of EOC and stays valid until next EOC rising edge.	19	DB5	Data output 5.
8	DB3	Data output 3.	20	DB6	Data output 6.
9	OE	Output enable input. When OE = 0, DB0–DB7 are in high impedance state; OE = 1, DB0–DB7 are active outputs.	21	DB7	Data output 7.
10	CLK	Clock. Clock input provides timing for A/D converter, S/H, and digital interface.	22	ALE	Address latch enable. Input to latch in the digital address (ADDR2–0) on the rising edge of the multiplexer.
11	V _{CC}	Positive supply. 5V ± 10%.	23	ADDR0	Address input 0 to multiplexer. Digital input for selecting analog input.
12	+V _{REF}	Positive reference voltage.	24	ADDR1	Address input 1 to multiplexer. Digital input for selecting analog input.
			25	ADDR2	Address input 2 to multiplexer. Digital input for selecting analog input.
			26	IN0	Analog input 0.
			27	IN1	Analog input 1.
			28	IN2	Analog input 2.

ABSOLUTE MAXIMUM RATINGS

(Note 1)

Supply Voltage, V_{CC}	6.5V
Voltage	
Logic Inputs	-0.3V to $V_{CC} + 0.3V$
Analog Inputs	-0.3V to $V_{CC} + 0.3V$
Input Current per Pin (Note 2)	$\pm 25mA$
Storage Temperature	-65°C to +150°C
Package Dissipation	
at $T_A = 25^\circ C$ (Board Mount)	875mW
Lead Temperature (Soldering 10 sec.)	
Dual-In-Line Package (Plastic)	260°C

Molded Chip Carrier Package

Vapor Phase (60 sec.) 215°C

Infrared (15 sec.) 220°C

OPERATING CONDITIONS

Supply Voltage, V_{CC}	4.5V _{DC} to 6.3V _{DC}
Temperature Range (Note 3)	$T_{MIN} - T_A - T_{MAX}$
ML2258BIP, ML2258BIQ, ML2258CIP,	
ML2258CIQ	-40°C to +85°C

ELECTRICAL CHARACTERISTICS

Unless otherwise specified, $T_A = T_{MIN}$ to T_{MAX} , $V_{CC} = +V_{REF} = 5V \pm 10\%$, $-V_{REF} = GND$ and $f_{CLK} = 10.24MHz$

PARAMETER	NOTES	CONDITIONS	ML2258B			ML2258C			UNITS
			MIN	TYP (NOTE 4)	MAX	MIN	TYP (NOTE 4)	MAX	
Converter and Multiplexer									
Total Unadjusted Error	5, 7	$V_{REF} = V_{CC}$			$\pm 1/2$			± 1	LSB
+ V_{REF} Voltage Range	6		$-V_{REF}$		$V_{CC} + 0.1$	$-V_{REF}$		$V_{CC} + 0.1$	V
- V_{REF} Voltage Range	6		$GND - 0.1$		+ V_{REF}	$GND - 0.1$		+ V_{REF}	V
Reference Input Resistance	5		14	20	28	14	20	28	k Ω
Analog Input Range	5, 8		$GND - 0.1$		$V_{CC} + 0.1$	$GND - 0.1$		$V_{CC} + 0.1$	V
Power Supply Sensitivity	6	DC, $V_{CC} = 5V \pm 10\%$		$\pm 1/32$	$\pm 1/4$		$\pm 1/32$	$\pm 1/4$	LSB
		100mVp-p, 100kHz sine on V_{CC} , $V_{IN} = 0$		$\pm 1/16$			$\pm 1/16$		LSB
I_{OFF} , Off Channel Leakage Current (Note 9)	5, 9	On Channel = V_{CC} Off Channel = 0V	-1			-1			μA
		On Channel = 0V Off Channel = V_{CC}			1		1		μA
I_{ON} , On Channel Leakage Current (Note 9)	5, 9	On Channel = 0V Off Channel = V_{CC}	-1			-1			μA
		On Channel = V_{CC} Off Channel = 0V			1		1		μA
Digital and DC									
$V_{IN(1)}$, Logical "1" Input Voltage	5		2.0			2.0			V
$V_{IN(0)}$, Logical "0" Input Voltage	5				0.8			0.8	V
$I_{IN(1)}$, Logical "1" Input Current	5	$V_{IN} = V_{CC}$			1			1	μA
$I_{IN(0)}$, Logical "0" Input Current	5	$V_{IN} = 0V$	-1			-1			μA
$V_{OUT(1)}$, Logical "1" Output Voltage	5	$I_{OUT} = -2mA$	4.0			4.0			V
$V_{OUT(0)}$, Logical "0" Output Voltage	5	$I_{OUT} = 2mA$			0.4			0.4	V
I_{OUT} , Three-State Output Current	5	$V_{OUT} = 0V$	-1			-1			μA
		$V_{OUT} = V_{CC}$			1		1		μA
I_{CC} , Supply Current	5			1.5	3		1.5	3	mA

ELECTRICAL CHARACTERISTICS (Continued)

SYMBOL	PARAMETER	NOTES	CONDITIONS	MIN	TYP (NOTE 4)	MAX	UNITS
AC and Dynamic Performance Characteristics (Note 10)							
t_{ACQ}	Sample and Hold Acquisition				4		$1/f_{CLK}$
f_{CLK}	Clock Frequency	5		100		10240	kHz
t_C	Conversion Time	5			67	$67 + 250\text{ns}$	$1/f_{CLK}$
SNR	Signal to Noise Ratio		$V_{IN} = 51\text{kHz}$, 5V sine. $f_{CLK} = 10.24\text{MHz}$ ($f_{SAMPLING} > 150\text{kHz}$). Noise is sum of all nonfundamental components up to 1/2 of $f_{SAMPLING}$		47		dB
THD	Total Harmonic Distortion		$V_{IN} = 51\text{kHz}$, 5V sine. $f_{CLK} = 10.24\text{MHz}$ ($f_{SAMPLING} > 150\text{kHz}$). THD is sum of 2, 3, 4, 5 harmonics relative to fundamental		-60		dB
IMD	Intermodulation Distortion		$V_{IN} = f_A + f_B$. $f_A = 49\text{kHz}$, 2.5V sine. $f_B = 47.8\text{kHz}$, 2.5V sine, $f_{CLK} = 10.24\text{MHz}$ ($f_{SAMPLING} > 150\text{kHz}$). IMD is ($f_A + f_B$), ($f_A - f_B$), ($2f_A + f_B$), ($2f_A - f_B$), ($f_A + 2f_B$), ($f_A - 2f_B$) relative to fundamental		-60		dB
FR	Frequency Response		$V_{IN} = 0$ to 50kHz. 5V sine relative to 1kHz		0.1		dB
t_{DC}	Clock Duty Cycle	6, 11		40		60	%
t_{EOC}	End of Conversion Delay	5			8	$8 + 250\text{ns}$	$1/f_{CLK}$
t_{WS}	Start Pulse Width	5		50			ns
t_{SS}	Start Pulse Setup Time	6, 12	Synchronous only	40			ns
t_{WALE}	Address Latch Enable Pulse Width	5		50			ns
t_S	Address Setup	5		0			ns
t_H	Address Hold	5		50			ns
$t_{H1, H0}$	Output Enable for DB0–DB7	6	Figure 1, $C_L = 50\text{pF}$			100	ns
		6	Figure 1, $C_L = 10\text{pF}$			50	ns
$t_{1H, 0H}$	Output Disable for DB0–DB7	6	Figure 1, $C_L = 50\text{pF}$			200	ns
		6	Figure 1, $C_L = 10\text{pF}$			100	ns
C_{IN}	Capacitance of Logic Input				5		pF
C_{OUT}	Capacitance of Logic Outputs				10		pF

Note 1: Absolute maximum ratings are limits beyond which the life of the integrated circuit may be impaired. All voltages unless otherwise specified are measured with respect to ground.

Note 2: When the input voltage (V_{IN}) at any pin exceeds the power supply rails ($V_{IN} < V_-$ or $V_{IN} > V_+$) the absolute value of current at that pin should be limited to 25mA or less.

Note 3: -40°C to $+85^\circ\text{C}$ operating temperature range devices are 100% tested with temperature limits guaranteed by 100% testing, sampling, or by correlation with worst-case test conditions.

Note 4: Typicals are parametric norm at 25°C .

Note 5: Parameter guaranteed and 100% production tested.

Note 6: Parameter guaranteed. Parameters not 100% tested are not in outgoing quality level calculation.

Note 7: Total unadjusted error includes offset, full scale, linearity, multiplexer and sample and hold errors.

Note 8: For $-V_{REF} \cdot V_{IN}$ (+) the digital output code will be 0000 0000. Two on-chip diodes are tied to each analog input which will forward conduct for analog input voltages one diode drop below ground or one diode drop greater than the V_{CC} supply. Be careful, during testing at low V_{CC} levels (4.5V), as high level analog inputs (5V) can cause this input diode to conduct — especially at elevated temperatures, and cause errors for analog inputs near full scale. The spec allow 100mV forward bias of either diode. This means that as long as the analog V_{IN} or V_{REF} does not exceed the supply voltage by more than 100mV, the output code will be correct. To achieve an absolute $0V_{DC}$ to $5V_{DC}$ input voltage range will therefore require a minimum supply voltage of $4.900V_{DC}$ over temperature variations, initial tolerance and loading.

Note 9: Leakage current is measured with the clock not switching.

Note 10: $C_L = 50\text{pF}$, timing measured at 50% point.

Note 11: A 40% to 60% clock duty cycle range insures proper operation at all clock frequencies. In the case that an available clock has a duty cycle outside of these limits, the minimum time the clock is high or the minimum time the clock is low must be at least 40ns. The maximum time the clock can be high or low is 60 μs .

Note 12: The conversion start setup time requirement only needs to be satisfied if a conversion must be synchronized to a given clock rising edge. If the setup time is not met, start conversion will have an uncertainty of one clock pulse.

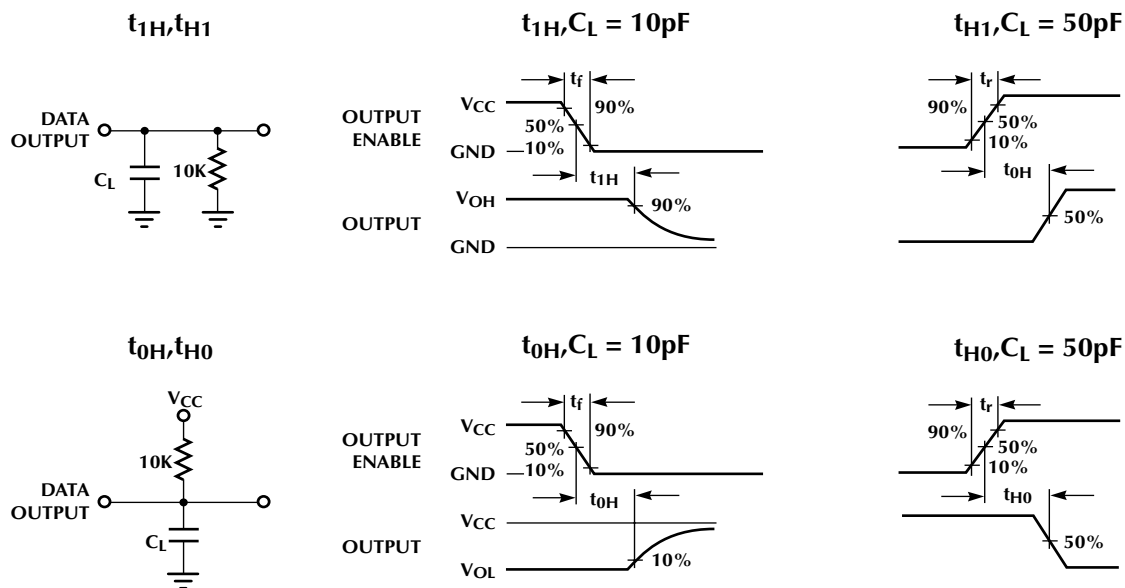

Figure 1. High Impedance Test Circuits and Waveforms

TYPICAL PERFORMANCE CURVES

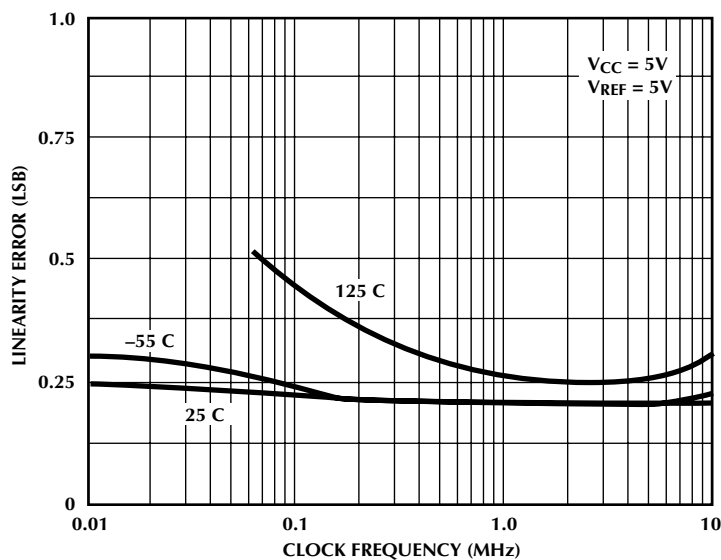

Figure 2. Linearity Error vs f_{CLK}

TYPICAL PERFORMANCE CURVES (Continued)

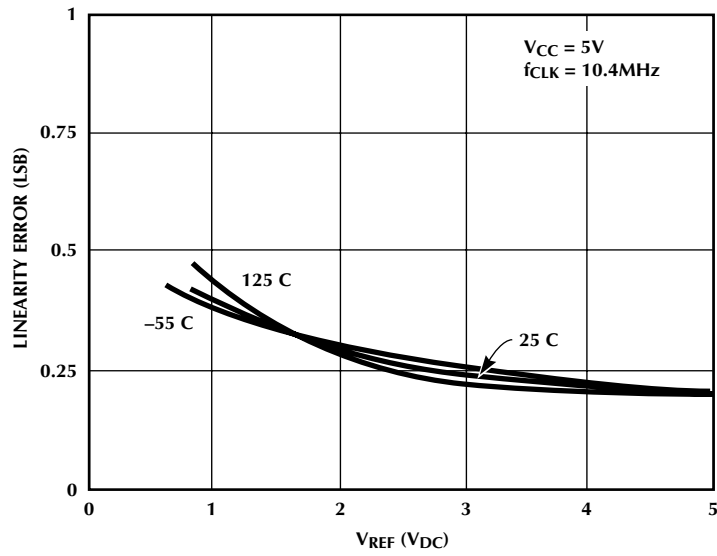

Figure 3. Linearity Error vs V_{REF} Voltage

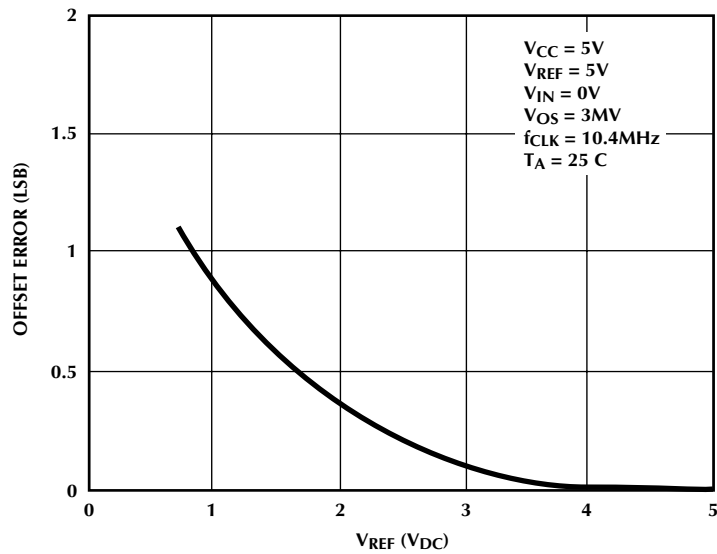

Figure 4. Unadjusted Offset Error vs V_{REF} Voltage

1.0 FUNCTIONAL DESCRIPTION

1.1 MULTIPLEXER ADDRESSING

The ML2258 contains an 8-channel single ended analog multiplexer. A particular input channel is selected by using the address decoder. The relationship between the address inputs, ADDR0–ADDR2, and the analog input selected is shown in Table 1. The address inputs are latched into the decoder on the rising edge of the address latch signal ALE.

SELECTED ANALOG CHANNEL	ADDRESS INPUT		
	ADDR2	ADDR1	ADDR0
IN0	0	0	0
IN1	0	0	1
IN2	0	1	0
IN3	0	1	1
IN4	1	0	0
IN5	1	0	1
IN6	1	1	0
IN7	1	1	1

Table 1. Multiplexer Address Decoding

1.2 A/D CONVERTER

The A/D converter uses successive approximation to perform the conversion. The converter is composed of the successive approximation register, the DAC and the comparator.

The DAC generates the precise levels that determine the linearity and accuracy of the conversion. The DAC is composed of a capacitor upper array and a resistor lower array. The capacitor upper array generates the 4 MSB decision levels while the series resistor lower array generates the 4 LSB decision levels. A switch decoder tree is used to decode the proper level from both arrays.

The capacitor/resistor array offers fast conversion, superior linearity and accuracy since matching is only required between $2^4 = 16$ elements (as opposed to $2^8 = 256$ elements in conventional designs). And since the levels are based on the ratio of capacitors to capacitors and resistors to resistors, the accuracy and long term stability of the converter is improved. This also guarantees monotonicity and no missing codes, as well as eliminating any linearity temperature or power supply dependence.

The successive approximation register is a digital block used to store the bit decisions from the conversion.

The comparator design is unique in that it is fully differential and auto-zeroed. The fully differential architecture provides excellent noise immunity, excellent power supply rejection, and wide common mode range. The comparator is auto zeroed at the start of each conversion in order to remove any DC offset and full scale gain error, thus improving accuracy and linearity.

Another advantage of the capacitor array approach used in the ML2258 over conventional designs is the inherent sample and hold function. This true S/H allows an accurate conversion to be done on the input even if the analog signal is not stable. Linearity and accuracy are maintained for analog signals up to 1/2 the sampling frequency. As a result, input signals up to 75kHz can be converted without degradation in linearity or accuracy.

The sequence of events during a conversion is shown in figure 5. The rising edge of a START pulse resets the internal registers and the falling edge initiates a conversion on the next rising edge of CLK. Four CLK pulses later, sampling of the analog input begins. The input is then sampled for the next four CLK periods until EOC goes low. EOC goes low on the rising edge of the 8th CLK pulse indicating that the conversion is now beginning. The actual conversion now takes place for the next 56 CLK pulses, one bit for each 7 CLK pulses. After the conversion is done, the data is updated on DB0–DB7 and EOC goes high on the rising edge of the 67th CLK pulse, indicating that the conversion has been completed and data is valid on DB0–DB7. The data will stay

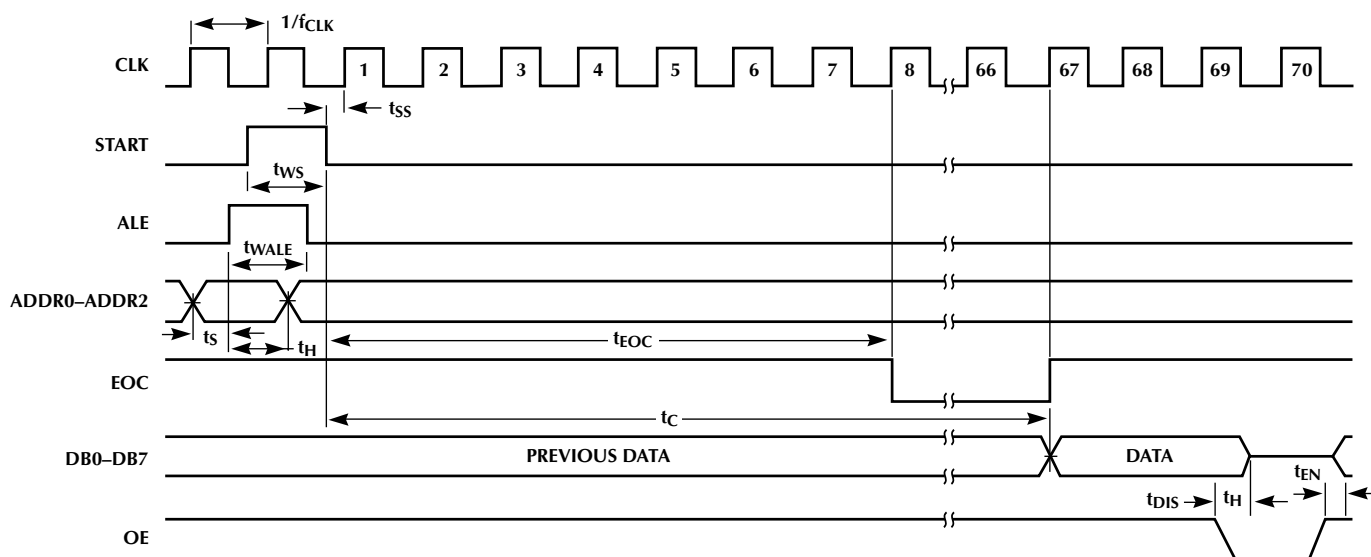

Figure 5. Timing Diagram

valid on DB0–DB7 until the next conversion updates the data word on the next rising edge of EOC.

A conversion can be interrupted and restarted at any time by a new START pulse.

1.3 ANALOG INPUTS AND SAMPLE/HOLD

The ML2258 has a true sample and hold circuit which samples both the selected input and ground simultaneously. This simultaneous sampling with a true S/H will give common mode rejection and AC linearity performance that is superior to devices where the two input terminals are not sampled at the same instant and where true sample and hold capability does not exist. Thus, the ML2258 can reject AC common mode signals from DC–50kHz as well as maintain linearity for signals from DC–50kHz.

The plot below (figure 6) shows a 2048 point FFT of the ML2258 converting a 50kHz, 0 to 5V, low distortion sine wave input. The ML2258 samples and digitizes, at its specified accuracy, dynamic input signals with frequency components up to the Nyquist frequency (one-half the sampling rate). The output spectra yields precise measurements of input signal level, harmonic components, and signal to noise ratio up to the 8-bit level. The near-ideal signal to noise ratio is maintained independent of increasing analog input frequencies to 50kHz.

The signal at the analog input is sampled during the interval when the sampling switch is open prior to conversion start. The sampling window (S/H acquisition time) is 4 CLK periods long and occurs 4 CLK periods after START goes low. When the sampling switch closes at the start of the S/H acquisition time, 8pF of capacitance is thrown onto the analog input. 4 CLK periods later, the sampling switch opens, the signal present at analog input is stored and conversion starts. Since any error on the analog input at the end of the S/H acquisition time will cause additional conversion error, care should be taken to insure adequate settling and charging time from the

source. If more charging or settling time is needed to reduce these analog input errors, a longer CLK period can be used.

The ML2258 has improved latchup immunity. Each analog input has dual diodes to the supply rails, and a minimum of $\pm 25\text{mA}$ ($\pm 100\text{mA}$ typically) can be injected into each analog input without causing latchup.

1.4 REFERENCE

The voltage applied to the $+V_{\text{REF}}$ and $-V_{\text{REF}}$ inputs defines the voltage span of the analog input (the difference between V_{INMAX} and V_{INMIN}) over which the 256 possible output codes apply. The devices can be used in either ratiometric applications or in systems requiring absolute accuracy. The reference pins must be connected to a voltage source capable of driving the reference input resistance, typically 20k Ω .

In a ratiometric system, the analog input voltage is proportional to the voltage used for the A/D reference. This voltage is typically the system power supply, so the $+V_{\text{REF}}$ pin can be tied to V_{CC} and $-V_{\text{REF}}$ tied to GND. This technique relaxes the stability requirements of the system reference as the analog input and A/D reference move together maintaining the same output code for a given input condition.

For absolute accuracy, where the analog input varies between specific voltage limits, the reference pins can be biased with a time and temperature stable voltage source.

In contrast to the ADC0808 and ADC0809, the ML2258 $-V_{\text{REF}}$ and $+V_{\text{REF}}$ reference values do not have to be symmetric around one half of the supply. $+V_{\text{REF}}$ and $-V_{\text{REF}}$ can be at any voltage between V_{CC} and GND. In addition, the difference between $+V_{\text{REF}}$ and $-V_{\text{REF}}$ can be set to small values for conversions over smaller voltage ranges. Particular care must be taken with regard to noise pickup, circuit layout and system error voltage sources when operating with a reduced span due to the increased sensitivity of the converter.

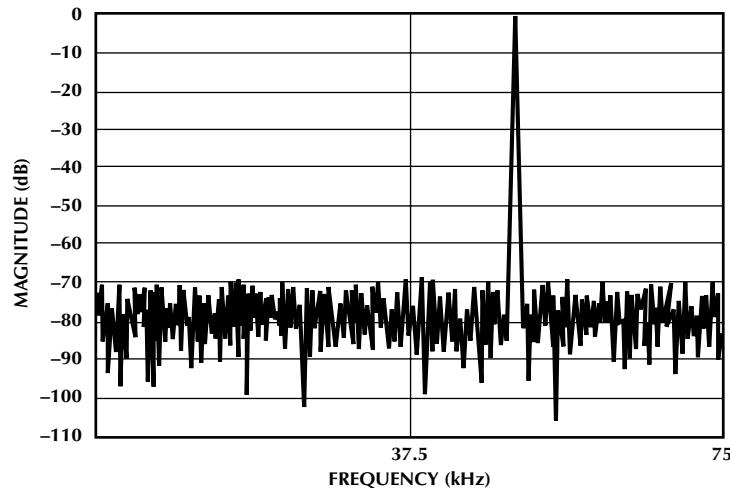

Figure 6. Output Spectrum

1.5 POWER SUPPLY AND REFERENCE DECOUPLING

A 10 μ F electrolytic capacitor is recommended to bypass V_{CC} to GND, using as short a lead length as possible. In addition, with clock frequencies above 1MHz, a 0.1 μ F ceramic disc capacitor should be used to bypass V_{CC} to GND.

If REF+ and REF- inputs are driven by long lines, they should be bypassed by 0.1 μ F Ceramic disc capacitors at the reference pins (pins 12, 16).

1.6 DYNAMIC PERFORMANCE

Signal-to-Noise Ratio

Signal-to-noise ratio (SNR) is the measured signal to noise at the output of the converter. The signal is the rms magnitude of the fundamental. Noise is the rms sum of all the nonfundamental signals up to half the sampling frequency. SNR is dependent on the number of quantization levels used in the digitization process; the more levels, the smaller the quantization noise. The theoretical SNR for a sine wave is given by

$$\text{SNR} = (6.02N + 1.76)\text{dB}$$

where N is the number of bits. Thus for ideal 8-bit converter, SNR = 49.92dB.

Harmonic Distortion

Harmonic distortion is the ratio of the rms sum of harmonics to the fundamental. Total harmonic distortion (THD) of the ML2258 is defined as

$$\text{THD} = 20 \log \frac{\left(V_2^2 + V_3^2 + V_4^2 + V_5^2 \right)^{1/2}}{V_1}$$

where V_1 is the rms amplitude of the fundamental and V_2 , V_3 , V_4 , V_5 are the rms amplitudes of the individual harmonics.

Intermodulation Distortion

With inputs consisting of sine waves at two frequencies, f_A and f_B , any active device with nonlinearities will create distortion products, of order (m+n), at sum and difference frequencies of $mf_A + nf_B$, where m, n = 0, 1, 2, 3, Intermodulation terms are those for which m or n is not equal to zero. The ML2258 (IMD) intermodulation distortion specification includes the second order terms ($f_A + f_B$) and ($f_A - f_B$) and the third order terms ($2f_A + f_B$), ($2f_A - f_B$), ($f_A + 2f_B$) and ($f_A - 2f_B$) only.

1.7 DIGITAL INTERFACE

The analog inputs are selected by the digital addresses, ADDR0-ADDR2, and latched on the rising edge of ALE. This is described in the Multiplexer Addressing section.

A conversion is initiated by the rising edge of a START pulse. As long as this pulse is high, the internal logic is reset.

The sampling interval starts with the 4th CLK rising edge after a START falling edge and ends on the 8th rising edge of CLK, 4 CLK periods later. On the rising edge of the 8th CLK pulse, the conversion starts and EOC goes low.

Each bit conversion in the successive approximation process takes 7 CLK periods. On the rising edge of the 64th CLK pulse, the digital output of the conversion is updated on the outputs DB0-DB7. On the rising edge of the 65th CLK pulse, EOC goes high indicating the conversion is done and data on DB0-DB7 is valid.

One feature of the ML2258 over conventional devices is that the data is double-buffered. This means that the outputs DB0-DB7 will stay valid until updated at the end of the next conversion and will not become invalid when the next conversion starts. This facilitates interfacing with external logic of μ P.

The signal OE drives the data bus, DB0-DB7, into a high impedance state when held low. This allows the ML2258 to be tied directly to a μ P system bus without any latches or buffers.

2.0 TYPICAL APPLICATIONS

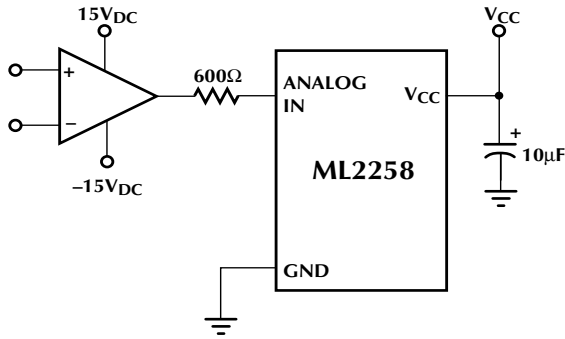

Figure 7. Protecting the Input from Overvoltage

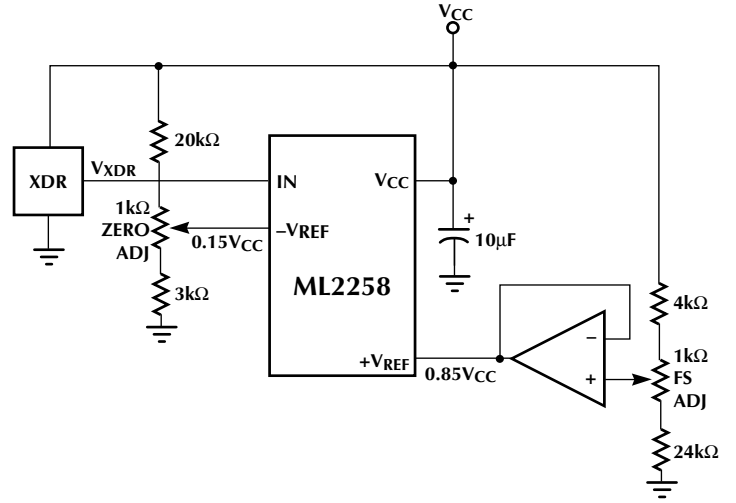

Figure 8. Operating with Ratiometric Transducers
 $15\% \text{ of } V_{CC} - V_{XDR} - 85\% \text{ of } V_{CC}$

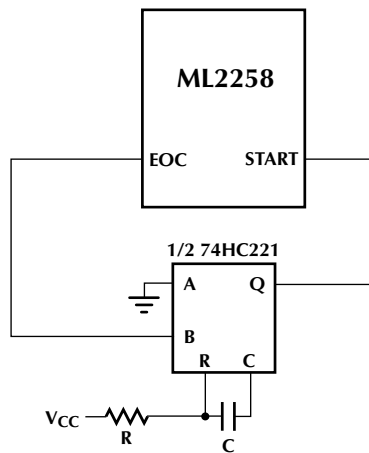
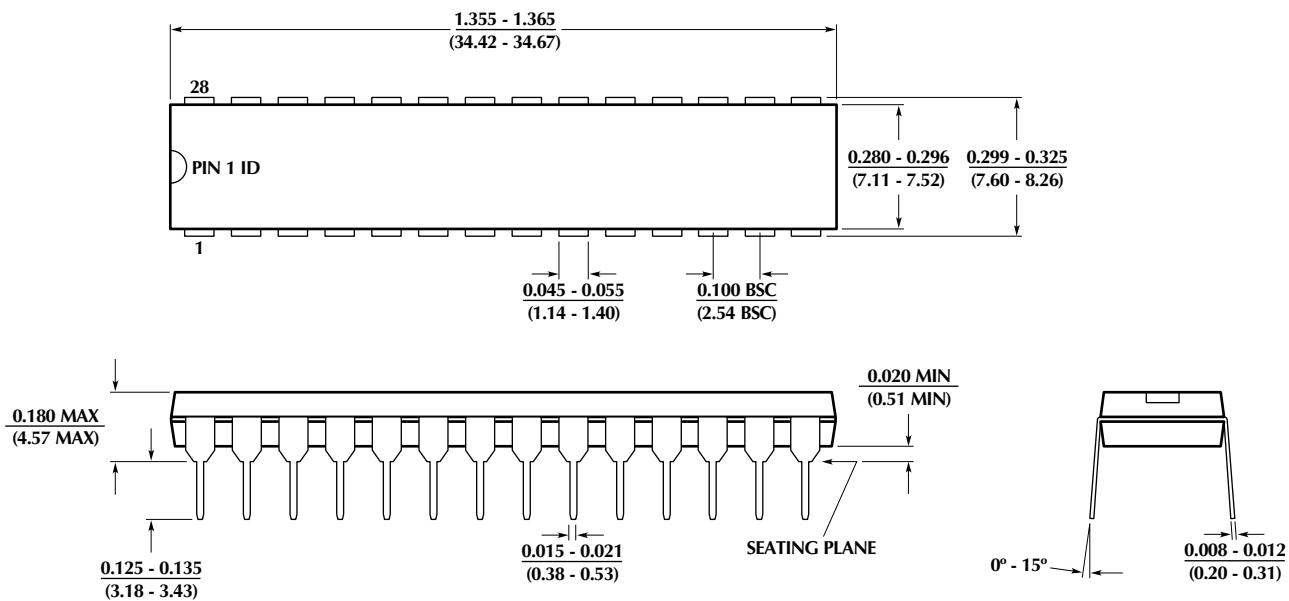

Figure 9. Continuous Conversion Mode

PHYSICAL DIMENSIONS inches (millimeters)

Package: P28N
28-Pin Narrow PDIP



Package: Q28
28-Pin PLCC

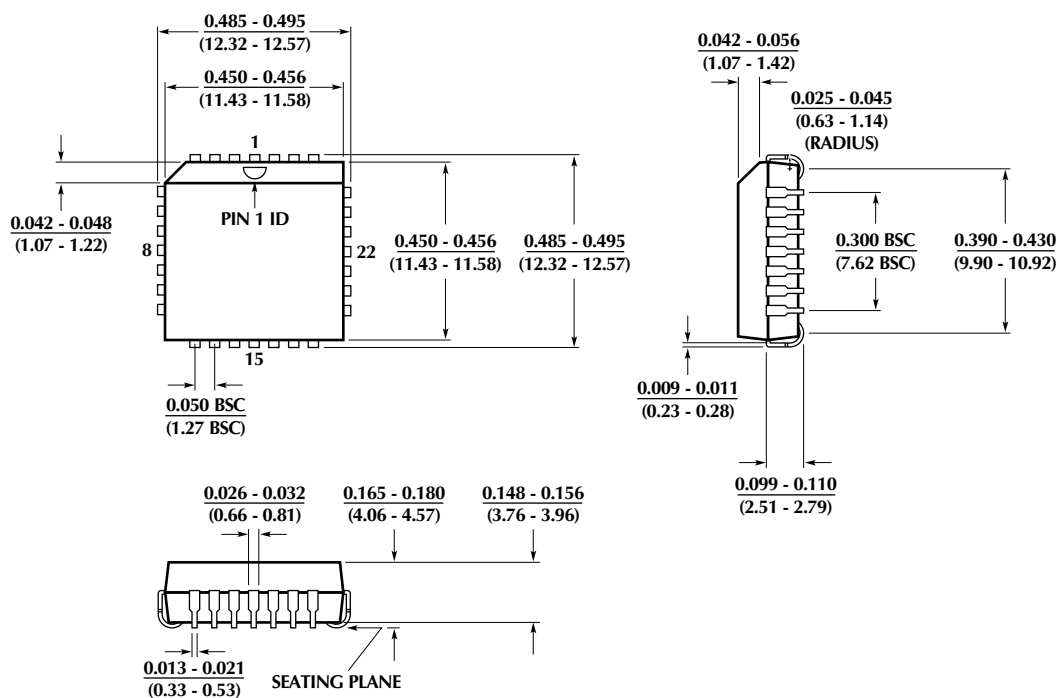

ORDERING INFORMATION

PART NUMBER	ALTERNATE PART NUMBER	TOTAL UNADJUSTED ERROR	TEMPERATURE RANGE	PACKAGE
ML2258BIP (EOL) ML2258BIQ	ADC0808CCN ADC0808CCV	±1/2 LSB	-40°C to 85°C -40°C to 85°C	Molded DIP (P28N) Molded PCC (Q28)
ML2258CIP (EOL) ML2258CIQ	ADC0809CCN ADC0809CCV	±1 LSB	-40°C to 85°C -40°C to 85°C	Molded DIP (P28N) Molded PCC (Q28)

© Micro Linear 1997.  **Micro Linear** is a registered trademark of Micro Linear Corporation

Products described in this document may be covered by one or more of the following patents, U.S.: 4,897,611; 4,964,026; 5,027,116; 5,281,862; 5,283,483; 5,418,502; 5,508,570; 5,510,727; 5,523,940; 5,546,017; 5,559,470; 5,565,761; 5,592,128; 5,594,376; Japan: 2598946; 2619299. Other patents are pending.

Micro Linear reserves the right to make changes to any product herein to improve reliability, function or design. Micro Linear does not assume any liability arising out of the application or use of any product described herein, neither does it convey any license under its patent right nor the rights of others. The circuits contained in this data sheet are offered as possible applications only. Micro Linear makes no warranties or representations as to whether the illustrated circuits infringe any intellectual property rights of others, and will accept no responsibility or liability for use of any application herein. The customer is urged to consult with appropriate legal counsel before deciding on a particular application.

2092 Concourse Drive
San Jose, CA 95131
Tel: 408/433-5200
Fax: 408/432-0295