

P89C669

80C51 8-bit microcontroller family with extended memory;
96 kB Flash with 2 kB RAM

Rev. 01 — 08 May 2003

Product data

1. General description

The P89C669 represents the first Flash microcontroller based on Philips Semiconductors' new 51MX core. The P89C669 features 96 kbytes of Flash program memory and 2 kbytes of data SRAM. In addition, this device is equipped with a Programmable Counter Array (PCA), a watchdog timer that can be configured to different time ranges through SFR bits, as well as two enhanced UARTs and byte based I²C-bus serial interface.

Philips Semiconductors' 51MX (Memory eXtension) core is an accelerated 80C51 architecture that executes instructions at twice the rate of standard 80C51 devices. The linear address range of the 51MX has been expanded to support up to 8 Mbytes of program memory and 8 Mbytes of data memory. It retains full program code compatibility to enable design engineers to re-use 80C51 development tools, eliminating the need to move to a new, unfamiliar architecture. The 51MX core also retains 80C51 bus compatibility to allow for the continued use of 80C51-interfaced peripherals and Application Specific Integrated Circuits (ASICs).

The P89C669 provides greater functionality, increased performance and overall lower system cost. By offering an embedded memory solution combined with the enhancements to manage the memory extension, the P89C669 eliminates the need for software work-arounds. The increased program memory enables design engineers to develop more complex programs in a high-level language like C, for example, without struggling to contain the program within the traditional 64 kbytes of program memory. These enhancements also greatly improve C Language efficiency for code size below 64 kbytes.

The P89C669 device contains a non-volatile Flash program memory that is both parallel programmable and serial In-System and In-Application Programmable. In-System Programming (ISP) allows the user to download new code while the microcontroller sits in the application. In-Application Programming (IAP) means that the microcontroller fetches new program code and reprograms itself while in the system. This allows for remote programming over a modem link. A default serial loader (boot loader) program in ROM allows serial In-System programming of the Flash memory via the UART without the need for a loader in the Flash code. For In-Application Programming, the user program erases and reprograms the Flash memory by use of standard routines contained in ROM.

The 51MX core is described in more detail in the *51MX Architecture Reference*.



PHILIPS

2. Features

2.1 Key features

- Extended features of the 51MX Core:
 - ◆ 23-bit program memory space and 23-bit data memory space
 - ◆ Linear program and data address range expanded to support up to 8 Mbytes each
 - ◆ Program counter expanded to 23 bits
 - ◆ Stack pointer extended to 16 bits enabling stack space beyond the 80C51 limitation
 - ◆ New 23-bit extended data pointer and two 24-bit universal pointers greatly improve C compiler code efficiency in using pointers to access variables in different spaces
- 100% binary compatibility with the classic 80C51 so that existing code is completely reusable
- Up to 24 MHz CPU clock with 6 clock cycles per machine cycle
- 96 kbytes of on-chip program Flash
- 2 kbytes of on-chip data RAM
- Programmable Counter Array (PCA)
- Two full-duplex enhanced UARTs
- Byte based Fast I²C serial interface (400 kbits/s)

2.2 Key benefits

- Increases program/data address range to 8 Mbytes each
- Enhances performance and efficiency for C programs
- Fully 80C51-compatible microcontroller
- Provides seamless and compelling upgrade path from classic 80C51
- Preserves 80C51 code base, investment/knowledge, and peripherals and ASICs
- Supported by wide range of 80C51 development systems and programming tools vendors
- The P89C669 makes it possible to develop applications at lower cost and with a reduced time-to-market

2.3 Complete features

- Fully static
- Up to 24 MHz CPU clock with 6 clock cycles per machine cycle
- 96 kbytes of on-chip Flash with In-System Programming (ISP) and In-Application Programming (IAP) capability
- 2 kbytes of on-chip RAM
- 23-bit program memory space and 23-bit data memory space
- Four-level interrupt priority
- 32 I/O lines (4 ports)
- Three Timers: Timer0, Timer1 and Timer2
- Two full-duplex enhanced UARTs with baud rate generator

- Byte based Fast I²C-bus serial interface (400 kbits/s)
- Framing error detection
- Automatic address recognition
- Power control modes
- Clock can be stopped and resumed
- Idle mode
- Power-down mode
- Second DPTR register
- Asynchronous port reset
- Programmable Counter Array (PCA) (compatible with 8xC51Rx+) with five Capture/Compare modules
- Low EMI (inhibit ALE)
- Watchdog timer with programmable prescaler for different time ranges (compatible with 8xC66x with added prescaler)

3. Ordering information

Table 1: Ordering information

Type number	Package		
	Name	Description	Version
P89C669FA	PLCC44	plastic leaded chip carrier; 44 leads	SOT187-2
P89C669BBD	LQFP44	plastic low profile quad flat package; 44 leads; body 10 × 10 × 1.4 mm	SOT389-1

3.1 Ordering options

Table 2: Ordering options

Type number	Memory		Temperature range	V _{DD} voltage range	Frequency
	OTP	RAM			
P89C669FA	96 kB	2048 B	−40 °C to +85 °C	4.5 to 5.5 V	0 to 24 MHz
P89C669BBD	96 kB	2048 B	0 °C to +70 °C	4.5 to 5.5 V	0 to 24 MHz

4. Block diagram

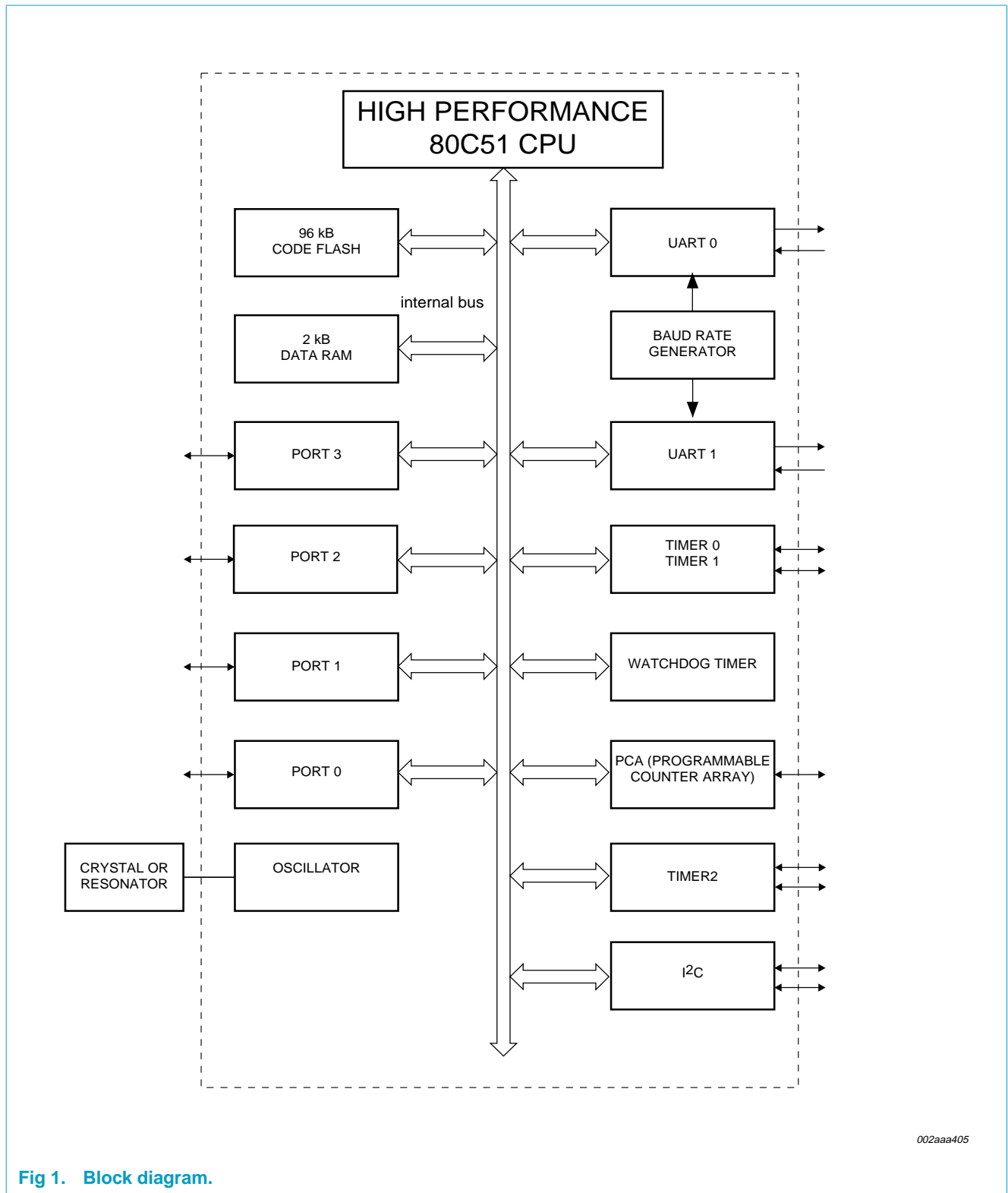

002aaa405

Fig 1. Block diagram.

5. Functional diagram

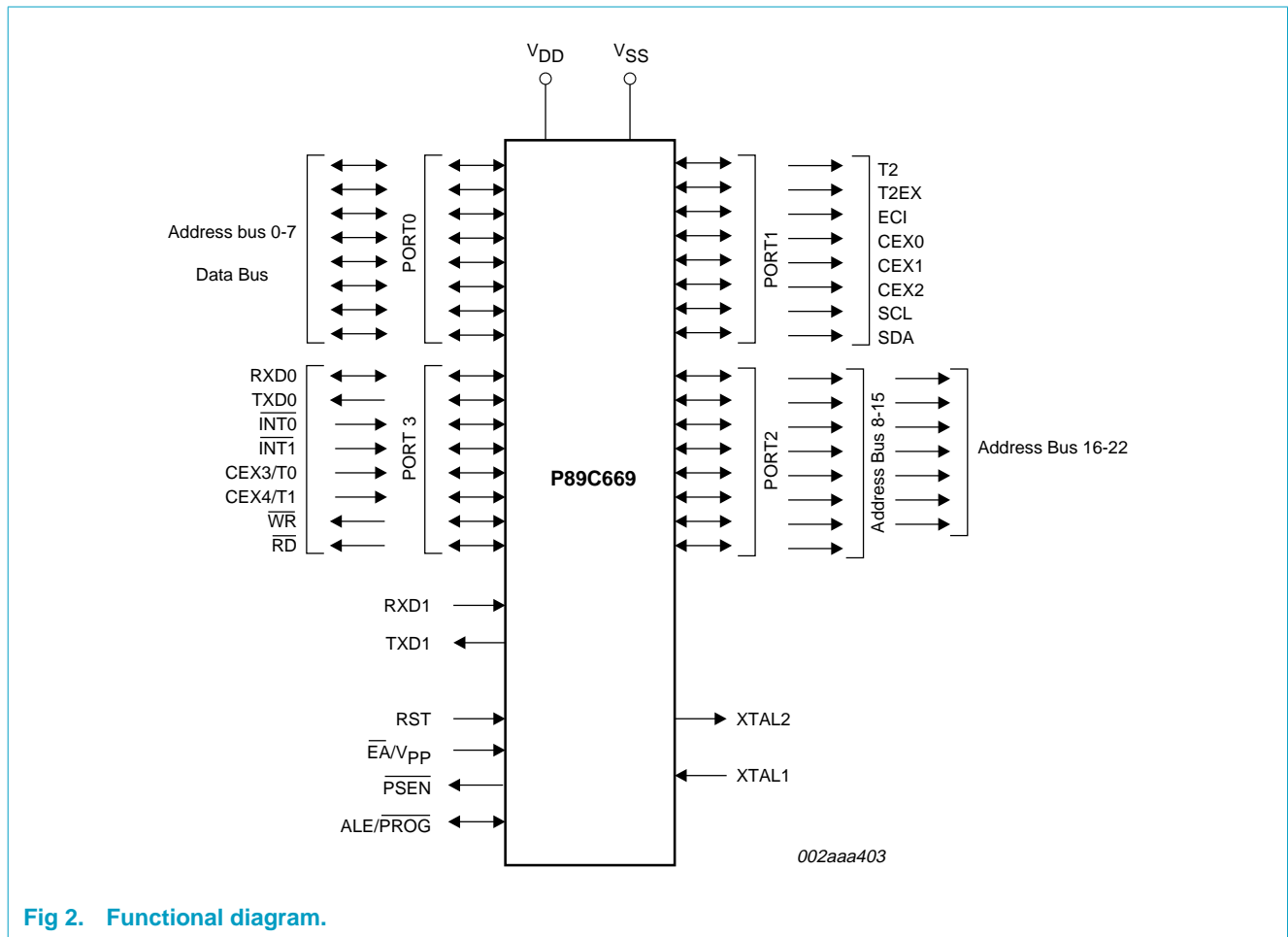

Fig 2. Functional diagram.

6. Pinning information

6.1 Pinning

6.1.1 Plastic leaded chip carrier

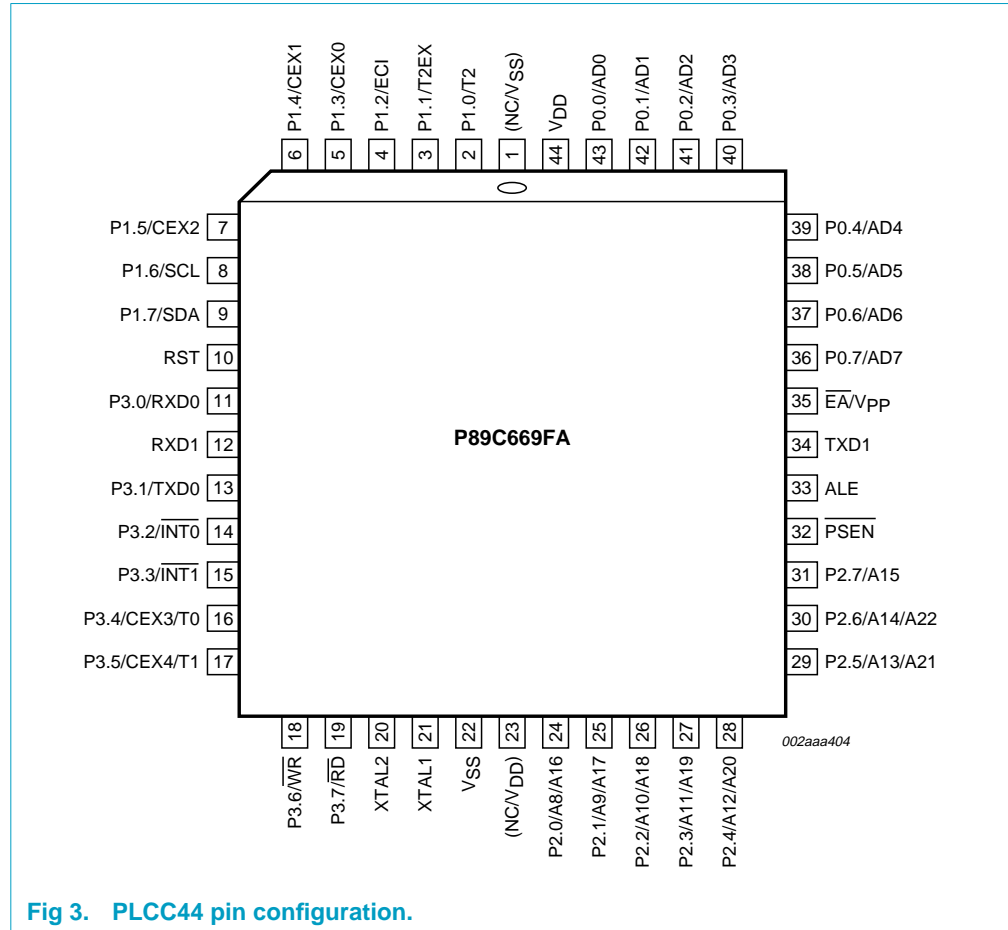

Fig 3. PLCC44 pin configuration.

6.1.2 Plastic low profile quad flat package

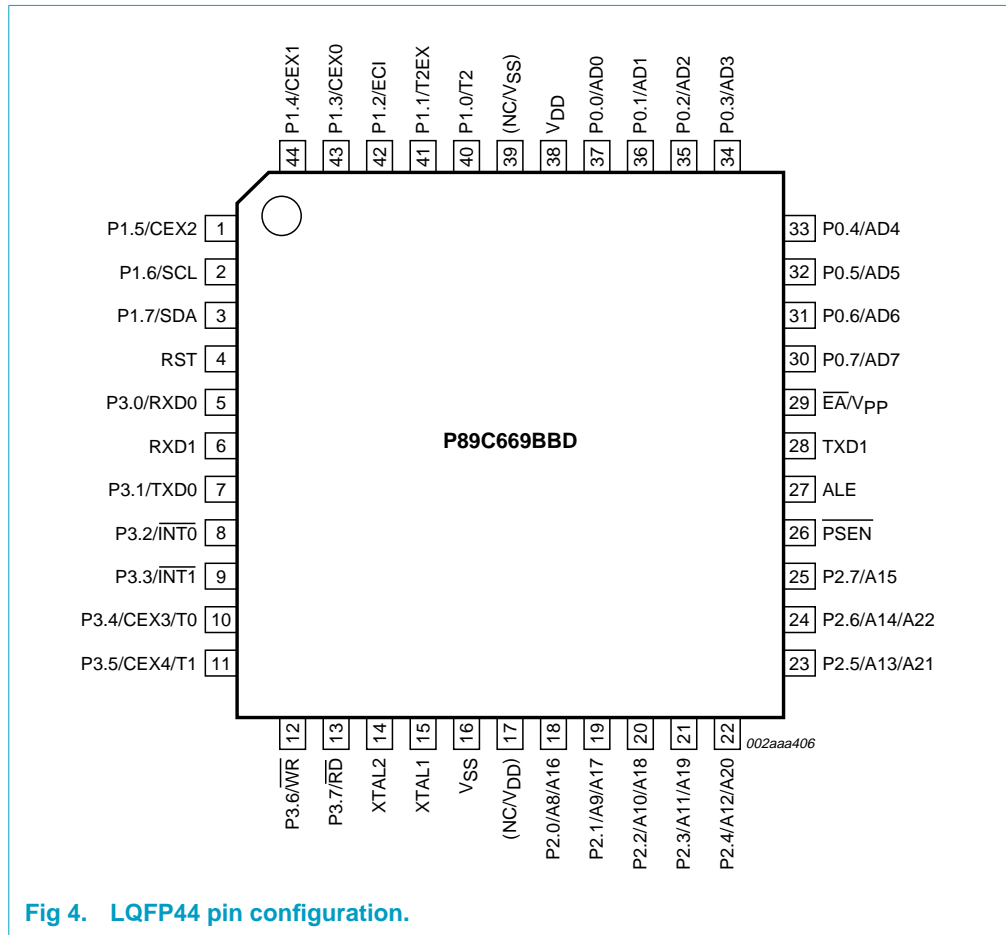

Fig 4. LQFP44 pin configuration.

6.2 Pin description

Table 3: Pin description

Symbol	Pin		Type	Description	
	PLCC	LQFP			
P0.0 - P0.7	43 - 36	30 - 37	I/O	Port 0: Port 0 is an open drain, bidirectional I/O port. Port 0 pins that have 1s written to them float and can be used as high-impedance inputs. Port 0 is also the multiplexed low-order address and data bus during accesses to external program and data memory. In this application, it uses strong internal pull-ups when emitting 1s.	
P1.0 - P1.7	2 - 9	1 - 3, 40 - 44	I/O	Port 1: Port 1 is an 8-bit bidirectional I/O port with internal pull-ups on all pins. Port 1 pins that have 1s written to them are pulled HIGH by the internal pull-ups and can be used as inputs. As inputs, Port 1 pins that are externally pulled LOW will source current because of the internal pull-ups.	
		2	40	I/O	<ul style="list-style-type: none"> • P1.0, T2 <ul style="list-style-type: none"> – Timer/Counter 2 external count input/Clock out
		3	41	I	<ul style="list-style-type: none"> • P1.1, T2EX <ul style="list-style-type: none"> – Timer/Counter 2 Reload/Capture/Direction Control
		4	42	I	<ul style="list-style-type: none"> • P1.2, ECI <ul style="list-style-type: none"> – External Clock Input to the PCA
		5	43	I/O	<ul style="list-style-type: none"> • P1.3, CEX0 <ul style="list-style-type: none"> – Capture/Compare External I/O for PCA module 0
		6	44	I/O	<ul style="list-style-type: none"> • P1.4, CEX1 <ul style="list-style-type: none"> – Capture/Compare External I/O for PCA module 1 (with pull-up on pin)
		7	1	I/O	<ul style="list-style-type: none"> • P1.5, CEX2 <ul style="list-style-type: none"> – Capture/Compare External I/O for PCA module 2 (with pull-up on pin)
		8	2	I/O	<ul style="list-style-type: none"> • P1.6, SCL <ul style="list-style-type: none"> – I²C serial clock (when I²C is used, this pin is open-drain and requires external pull-up due to I²C-bus specification)
		9	3	I/O	<ul style="list-style-type: none"> • P1.7, SDA <ul style="list-style-type: none"> – I²C serial data (when I²C is used, this pin is open-drain and requires external pull-up due to I²C-bus specification)
P2.0 - P2.7	24 - 31	18 - 25	I/O	<p>Port 2: Port 2 is a 8-bit bidirectional I/O port with internal pull-ups. Port 2 pins that have 1s written to them are pulled HIGH by the internal pull-ups and can be used as inputs. As inputs, port 2 pins that are externally being pulled LOW will source current because of the internal pull-ups. (See Section 9 “Static characteristics”, I_{IL}). Port 2 emits the high-order address byte during fetches from external program memory and during accesses to external data memory that use 16-bit addresses (MOVX @ DPTR) or 23-bit addresses (MOVX @ EPTR, EMOV). In this application, it uses strong internal pull-ups when emitting 1s. During accesses to external data memory that use 8-bit addresses (MOV @ Ri), port 2 emits the contents of the P2 Special Function Register.</p> <p>Note that when 23-bit address is used, address bits A16-A22 will be outputted to P2.0-P2.6 when ALE is HIGH, and address bits A8-A14 are outputted to P2.0-P2.6 when ALE is LOW. Address bit A15 is outputted on P2.7 regardless of ALE.</p>	

Table 3: Pin description...continued

Symbol	Pin		Type	Description
	PLCC	LQFP		
P3.0 - P3.7	11, 13 - 19	5, 7 - 13	I/O	Port 3: Port 3 is an 8-bit bidirectional I/O port with internal pull-ups. Port 3 pins that have 1s written to them are pulled HIGH by the internal pull-ups and can be used as inputs. As inputs, Port 3 pins that are externally pulled LOW will source current because of the internal pull-ups.
	11	5	I	<ul style="list-style-type: none"> • P3.0, RXD0 <ul style="list-style-type: none"> – Serial input port 0
	13	7	O	<ul style="list-style-type: none"> • P3.1, TXD0 <ul style="list-style-type: none"> – Serial output port 0
	14	8	I	<ul style="list-style-type: none"> • P3.2, $\overline{\text{INT0}}$ <ul style="list-style-type: none"> – External interrupt 0
	15	9	I	<ul style="list-style-type: none"> • P3.3, $\overline{\text{INT1}}$ <ul style="list-style-type: none"> – External interrupt 1
	16	10	I	<ul style="list-style-type: none"> • P3.4, T0/CEX3 <ul style="list-style-type: none"> – Timer0 external input/capture/compare external I/O for PCA module 3
	17	11	I	<ul style="list-style-type: none"> • P3.5, T1/CEX4 <ul style="list-style-type: none"> – Timer1 external input/capture/compare external I/O for PCA module 3
	18	12	O	<ul style="list-style-type: none"> • P3.6, $\overline{\text{WR}}$ <ul style="list-style-type: none"> – External data memory write strobe
	19	13	O	<ul style="list-style-type: none"> • P3.7, $\overline{\text{RD}}$ <ul style="list-style-type: none"> – External data memory read strobe
RXD1	12	6	I	<ul style="list-style-type: none"> • RXD1 <ul style="list-style-type: none"> – Serial input port 1 (with pull-up on pin)
TXD1	34	28	O	<ul style="list-style-type: none"> • TXD1 <ul style="list-style-type: none"> – Serial output port 1 (with pull-up on pin)
RST	10	4	I	Reset: A HIGH on this pin for two machine cycles, while the oscillator is running, resets the device. An internal diffused resistor to V_{SS} permits a power-on reset using only an external capacitor to V_{DD} .
ALE	33	27	O	Address Latch Enable: Output pulse for latching the LOW byte of the address during an access to external memory. In normal operation, ALE is emitted at a constant rate of $\frac{1}{6}$ the oscillator frequency, and can be used for external timing or clocking. Note that one ALE pulse is skipped during each access to external data memory. ALE can be disabled by setting SFR AUXR.0. With this bit is set, ALE will be active only during a MOVX instruction.
$\overline{\text{PSEN}}$	32	26	O	Program Store Enable: The read strobe to external program memory. When executing code from the external program memory, $\overline{\text{PSEN}}$ is activated twice each machine cycle, except that two $\overline{\text{PSEN}}$ activations are skipped during each access to external data memory. $\overline{\text{PSEN}}$ is not activated during fetches from internal program memory.
$\overline{\text{EA}}/V_{PP}$	35	29	I	External Access Enable/Programming Supply Voltage: $\overline{\text{EA}}$ must be externally held LOW to enable the device to fetch code from external program memory locations. If $\overline{\text{EA}}$ is held HIGH, the device executes from internal program memory. The value on the $\overline{\text{EA}}$ pin is latched when RST is released and any subsequent changes have no effect.
XTAL1	21	15	I	Crystal 1: Input to the inverting oscillator amplifier and input to the internal clock generator circuits.

Table 3: Pin description...continued

Symbol	Pin		Type	Description
	PLCC	LQFP		
XTAL2	20	14	O	Crystal 2: Output from the inverting oscillator amplifier.
V _{SS}	22	16	I	Ground: 0 V reference.
V _{DD}	44	38	I	Power Supply: This is the power supply voltage for normal operation as well as Idle and Power-down modes.
(NC/V _{SS})	1	39	I	No Connect/Ground: This pin is internally connected to V _{SS} on the P89C669. If connected externally, this pin must only be connected to the same V _{SS} as at pin 22. (Note: Connecting the second pair of V _{SS} and V _{DD} pins is not required. However, they may be connected in addition to the primary V _{SS} and V _{DD} pins to improve power distribution, reduce noise in output signals, and improve system-level EMI characteristics.)
(NC/V _{DD})	23	17	I	No Connect/Power Supply: This pin is internally connected to V _{DD} on the P89C669. If connected externally, this pin must only be connected to the same V _{DD} as at pin 44. (Note: Connecting the second pair of V _{SS} and V _{DD} pins is not required. However, they may be connected in addition to the primary V _{SS} and V _{DD} pins to improve power distribution, reduce noise in output signals, and improve system-level EMI characteristics.)

7. Functional description

7.1 Flash memory description

The P89C669 contains 96 kbytes of Flash program memory. It is organized as 12 separate blocks, each block containing 8 kbytes.

The P89C669 Flash memory augments EPROM functionality with in-circuit electrical erasure and programming. The Flash can be read and written as bytes. The Chip Erase operation will erase the entire program memory. The Block Erase function can erase any Flash byte block. In-system programming and standard parallel programming are both available. On-chip erase and write timing generation contribute to a user friendly programming interface. The P89C669 Flash reliably stores memory contents even after 10,000 erase and program cycles. The cell is designed to optimize the erase and programming mechanisms. In addition, the combination of advanced tunnel oxide processing and low internal electric fields for erase and programming operations produces reliable cycling. The P89C669 uses a +5 V V_{PP} supply to perform the Program/Erase algorithms.

- Flash internal program memory with Block Erase.
- Internal 4 kbytes Boot Flash, containing low-level in-system programming routines and a default UART loader. User program can call these routines to perform In-Application Programming (IAP). The BootFlash can be turned off to provide access to the full 8 Mbytes memory space.
- Boot vector allows user provided Flash loader code to reside anywhere in the Flash memory space. This configuration provides flexibility to the user.
- Default loader in BootFlash allows programming via the UART interface without the need for a user provided loader.
- Up to 8 Mbytes of external program memory if the internal program memory is disabled ($\overline{EA} = 0$).
- +5 V programming and erase voltage.
- Read/Programming/Erase using ISP/IAP:
 - Byte Programming (20 μ s).
 - Typical quick erase times (including preprogramming time):
 - Block Erase (8 kbytes) in 1 second.
 - Full Erase (96 kbytes) in 1 second.
- Parallel programming with 87C51-like hardware interface to programmer.
- Programmable security for the code in the Flash.
- 10,000 minimum erase/program cycles for each byte.
- 10 year minimum data retention.

7.2 Memory arrangement

P89C669 has 96 kbytes of Flash (MX universal map range: 80:0000-81:7FFF) and 2 kbytes of on-chip RAM:

Table 4: Memory arrangement

Data memory		Size (Bytes) and MX universal memory map range
Type	Description	P89C669
DATA	memory that can be addressed both directly and indirectly; can be used as stack	128 (7F:0000-7F:007F)
IDATA	superset of DATA; memory that can be addressed indirectly (where direct address for upper half is for SFR only); can be used as stack	256 (7F:0000-7F:00FF)
EDATA	superset of DATA/IDATA; memory that can be addressed indirectly using Universal Pointers (PR0,1); can be used as stack	1280 (7F:0000-7F:04FF)
XDATA	memory (on-chip 'External Data') that is accessed via the MOVX/EMOV instructions using DPTR/EPTR	768 (00:0000-00:02FF)

For more detailed information, please refer to the *P89C669 User Manual*.

7.3 Special function registers

Special Function Register (SFR) accesses are restricted in the following ways:

- User must **not** attempt to access any SFR locations not defined.
- Accesses to any defined SFR locations must be strictly for the functions for the SFRs.
- SFR bits labeled '-', '0', or '1' can **only** be written and read as follows:
 - '-' **must** be written with '0', but can return any value when read (even if it was written with '0'). It is a reserved bit and may be used in future derivatives.
 - '0' **must** be written with '0', and will return a '0' when read.
 - '1' **must** be written with '1', and will return a '1' when read.

Table 5: Special function registers

Name	Description	SFR addr.	Bit functions and addresses								Reset value	
			MSB				LSB					
			Bit address	E7	E6	E5	E4	E3	E2	E1	E0	
ACC ^[1]	Accumulator	E0H										00H
AUXR ^[2]	Auxiliary Function Register	8EH	-	-	-	-	-	-	-	EXTRAM	AO	00H ^[6]
AUXR1 ^[2]	Auxiliary Function Register 1	A2H	-	-	ENBOOT	-	GF2	0	-	-	DPS	00H ^[6]
			Bit address	F7	F6	F5	F4	F3	F2	F1	F0	
B ^[1]	B Register	F0H										00H
BRGCON ^[2]	Baud Rate Generator Control	85H ^[3]	-	-	-	-	-	-	-	S0BRGS	BRGEN	00H ^[6]
BRGR0 ^{[2][5]}	Baud Rate Generator Rate LOW	86H ^[3]										00H
BRGR1 ^{[2][5]}	Baud Rate Generator Rate HIGH	87H ^[3]										00H ^[6]
CCAP0H ^[2]	Module 0 Capture HIGH	FAH										XXH
CCAP1H ^[2]	Module 1 Capture HIGH	FBH										XXH
CCAP2H ^[2]	Module 2 Capture HIGH	FCH										XXH
CCAP3H ^[2]	Module 3 Capture HIGH	FDH										XXH
CCAP4H ^[2]	Module 4 Capture HIGH	FEH										XXH
CCAP0L ^[2]	Module 0 Capture LOW	EAH										XXH
CCAP1L ^[2]	Module 1 Capture LOW	EBH										XXH
CCAP2L ^[2]	Module 2 Capture LOW	ECH										XXH
CCAP3L ^[2]	Module 3 Capture LOW	EDH										XXH
CCAP4L ^[2]	Module 4 Capture LOW	EEH										XXH
CCAPM0 ^[2]	Module 0 Mode	DAH	-	ECOM_0	CAPP_0	CAPN_0	MAT_0	TOG_0	PWM_0	ECCF_0		00H ^[6]
CCAPM1 ^[2]	Module 1 Mode	DBH	-	ECOM_1	CAPP_1	CAPN_1	MAT_1	TOG_1	PWM_1	ECCF_1		00H ^[6]
CCAPM2 ^[2]	Module 2 Mode	DCH	-	ECOM_2	CAPP_2	CAPN_2	MAT_2	TOG_2	PWM_2	ECCF_2		00H ^[6]
CCAPM3 ^[2]	Module 3 Mode	DDH	-	ECOM_3	CAPP_3	CAPN_3	MAT_3	TOG_3	PWM_3	ECCF_3		00H ^[6]
CCAPM4 ^[2]	Module 4 Mode	DEH	-	ECOM_4	CAPP_4	CAPN_4	MAT_4	TOG_4	PWM_4	ECCF_4		00H ^[6]
			Bit address	DF	DE	DD	DC	DB	DA	D9	D8	
CCON ^{[1][2]}	PCA Counter Control	D8H	CF	CR	-	CCF4	CCF3	CCF2	CCF1	CCF0		00H ^[6]
CH ^[2]	PCA Counter HIGH	F9H										00H
CL ^[2]	PCA Counter LOW	E9H										00H
CMOD ^[2]	PCA Counter Mode	D9H	CIDL	WDTE	-	-	-	CPS1	CPS0	ECF		00H ^[6]
DPTR	Data Pointer (2 bytes)											00H

Table 5: Special function registers...continued

Name	Description	SFR addr.	Bit functions and addresses								Reset value
			MSB				LSB				
DPH	Data Pointer HIGH	83H									00H
DPL	Data Pointer LOW	82H									00H
EPL ^[2]	Extended Data Pointer LOW	FCH ^[3]									00H
EPM ^[2]	Extended Data Pointer Middle	FDH ^[3]									00H
EPH ^[2]	Extended Data Pointer HIGH	FEH ^[3]									00H
I2ADR	I ² C Slave Address Register	94H	addr.6	addr.5	addr.4	addr.3	addr.2	addr.1	addr.0	GC	00H
I2CON	I ² C Control Register	91H	-	I2EN	STA	STO	SI	AA	-	CRSEL	00H
I2DAT	I ² C Data Register	93H									
I2CLH	I ² C Clock Generator HIGH Register	96H									00H
I2CLL	I ² C Clock Generator LOW Register	95H									00H
I2STA	I ² C Status Register	92H	code.4	code.3	code.2	code.1	code.0	0	0	0	F8H
IEN0 ^[1]	Interrupt Enable 0	A8H	Bit address AF	AE	AD	AC	AB	AA	A9	A8	00H
			\overline{EA}	EC	ET2	ES0/ ES0R	ET1	EX1	ET0	EX0	
IEN1 ^[1]	Interrupt Enable 1	E8H	Bit address EF	EE	ED	EC	EB	\overline{EA}	E9	E8	00H ^[6]
			-	-	-	EI2C	-	ES1T	ES0T	ES1/ ES1R	
IP0 ^[1]	Interrupt Priority	B8H	Bit address BF	BE	BD	BC	BB	BA	B9	B8	00H
			-	PPC	PT2	PS0/ PS0R	PT1	PX1	PT0	PX0	
IP0H	Interrupt Priority 0 HIGH	B7H	-	PPCH	PT2H	PS0H/ PS0RH	PT1H	PX1H	PT0H	PX0H	00H
IP1 ^[1]	Interrupt Priority 1	F8H	Bit address FF	FE	FD	FC	FB	FA	F9	F8	00H ^[6]
			-	-	-	PI2C	-	PS1T	PS0T	PS1/ PS1R	
IP1H	Interrupt Priority 1 HIGH	F7H	-	-	-	PI2CH	-	PS1TH	PS0TH	PS1H/ PS1RH	00H ^[6]
MXCON ^[2]	MX Control Register	FFH ^[3]	-	-	-	-	-	EAM	ESMM	EIFM	00H ^[6]

Table 5: Special function registers...continued

Name	Description	SFR addr.	Bit functions and addresses								Reset value
			MSB				LSB				
		Bit address	87	86	85	84	83	82	81	80	
P0 ^[1]	Port 0	80H	AD7	AD6	AD5	AD4	AD3	AD2	AD1	AD0	FFH
		Bit address	97	96	95	94	93	92	91	90	
P1 ^[1]	Port 1	90H	CEX4	CEX3	CEX2/ SPICLK	CEX1/ MOSI	CEX0	ECI	T2EX	T2	FFH
		Bit address	A7	A6	A5	A4	A3	A2	A1	A0	
P2 ^[1]	Port 2	A0H	AD15	AD14/ AD22	ADA13/ AD21	AD12/ AD20	AD11/ AD19	AD10/ AD18	AD9/ AD17	AD8/ AD16	FFH
		Bit address	B7	B6	B5	B4	B3	B2	B1	B0	
P3 ^[1]	Port 3	B0H	RD	WR	T1	T0	INT1	INT0	TxD0	RxD0	FFH
PCON ^[2]	Power Control Register	87H	SMOD1	SMOD0	-	POF	GF1	GF0	PD	IDL	00H/ 10H ^[4]
		Bit address	D7	D6	D5	D4	D3	D2	D1	D0	
PSW ^[1]	Program Status Word	D0H	CY	AC	F0	RS1	RS0	OV	F1	P	00H
RCAP2H ^[2]	Timer2 Capture HIGH	CBH									00H
RCAP2L ^[2]	Timer2 Capture LOW	CAH									00H
		Bit address	9F	9E	9D	9C	9B	9A	99	98	
S0CON ^[1]	Serial Port 0 Control	98H	SM0_0/ FE_0	SM1_0	SM2_0	REN_0	TB8_0	RB8_0	TI_0	RI_0	00H
S0BUF	Serial Port 0 Data Buffer Register	99H									xxH
S0ADDR	Serial Port 0 Address Register	A9H									00H
S0ADEN	Serial Port 0 Address Enable	B9H									00H
S0STAT ^[2]	Serial Port 0 Status	8CH ^[3]	DBMOD_0	INTLO_0	CIDIS_0	DBISEL_0	FE_0	BR_0	OE_0	STINT_0	00H ^[6]
		Bit address	87^[3]	86^[3]	85^[3]	84^[3]	83^[3]	82^[3]	81^[3]	80^[3]	
S1CON ^{[1][2]}	Serial Port 1 Control	80H ^[3]	SM0_1/ FE_1	SM1_1	SM2_1	REN_1	TB8_1	RB8_1	TI_1	RI_1	00H
S1BUF ^[2]	Serial Port 1 Data buffer Register	81H ^[3]									XXH
S1ADDR ^[2]	Serial Port 1 Address Register	82H ^[3]									00H

Table 5: Special function registers...continued

Name	Description	SFR addr.	Bit functions and addresses								Reset value
			MSB				LSB				
S1ADEN ^[2]	Serial Port 1 Address Enable	83H ^[3]									00H
S1STAT ^[2]	Serial Port 1 Status	84H ^[3]	DBMOD_1	INTLO_1	CIDIS_1	DBISEL1	FE_1	BR_1	OE_1	STINT_1	00H ^[6]
SP	Stack Pointer (Stack Pointer LOW Byte)	81H									07H
SPE ^[2]	Stack Pointer HIGH	FBH ^[3]									00H
			Bit address	8F	8E	8D	8C	8B	8A	89	88
TCON ^[1]	Timer Control Register	88H	TF1	TR1	TF0	TR0	IE1	IT1	IE0	IT0	00H
			CF	CE	CD	CC	CB	CA	C9	C8	
T2CON ^{[1][2]}	Timer2 Control Register	C8H	TF2	EXF2	RCLK	TCLK	EXEN2	TR2	C/T $\bar{2}$	CP/RL $\bar{2}$	00H
T2MOD ^[2]	Timer2 Mode Control	C9H	-	-	-	-	-	-	T2OE	DCEN	00H ^[6]
TH0	Timer 0 HIGH	8CH									00H
TH1	Timer 1 HIGH	8DH									00H
TH2	Timer 2 HIGH	CDH									00H
TL0	Timer 0 LOW	8AH									00H
TL1	Timer 1 LOW	8BH									00H
TL2	Timer 2 LOW	CCH									00H
TMOD	Timer 0 and 1 Mode	89H	GATE	C/T	M1	M0	GATE	C/T	M1	M0	00H
WDTRST ^[2]	Watchdog Timer Reset	A6H									FFH
WDCON ^[2]	Watchdog Timer Control	8FH ^[3]	-	-	-	-	-	WDPRE2	WDPRE1	WDPRE0	00H ^[6]

[1] SFRs are bit addressable.

[2] SFRs are modified from or added to the 80C51 SFRs.

[3] Extended SFRs accessed by preceding the instruction with MX escape (opcode A5h).

[4] Power-on reset is 10H. Other reset is 00H.

[5] BRGR1 and BRGR0 must only be written if BRGEN in BRGCON SFR is '0'. If any of them is written if BRGEN = 1, result is unpredictable.

[6] The unimplemented bits (labeled '-') in the SFRs are X's (unknown) at all times. '1's should NOT be written to these bits, as they may be used for other purposes in future derivatives. The reset values shown for these bits are '0's although they are unknown when read.

7.4 Security bits

The P89C669 has security bits to protect users' firmware codes. With none of the security bits programmed, the code in the program memory can be verified. When only security bit 1 (see Table 6) is programmed, MOVC instructions executed from external program memory are disabled from fetching code bytes from the internal memory. \overline{EA} is latched on Reset and all further programming of EPROM is disabled. When security bits 1 and 2 are programmed, in addition to the above, verify mode is disabled. When all three security bits are programmed, all of the conditions above apply and all external program memory execution is disabled.

Table 6: EPROM security bits

Security Bits ^{[1][2]}				
	Bit 1	Bit 2	Bit 3	Protection description
1	U	U	U	No program security features enabled. Flash is programmable and verifiable.
2	P	U	U	MOVC instructions executed from external program memory are disabled from fetching code bytes from internal memory, \overline{EA} is sampled and latched on Reset, and further programming of the EPROM is disabled.
3	P	P	U	Same as 2, also verification is disabled.
4	P	P	P	Same as 3, external execution is disabled.

[1] P - programmed. U - unprogrammed.

[2] Any other combination of security bits is not defined.

8. Limiting values

Table 7: Limiting values

In accordance with the Absolute Maximum Rating System (IEC 60134).

Symbol	Parameter	Conditions	Min	Max	Unit
T _{amb}	operating temperature	under bias	0	+70	°C
			-40	+85	°C
T _{stg}	storage temperature range		-65	+150	°C
V _I	input voltage on \overline{EA}/V_{PP} pin to V _{SS}		0	+13	V
	input voltage on any other pin to V _{SS}		-0.5	V _{DD} + 0.5	V
I _I , I _O	maximum I _{OL} per I/O pin		-	20	mA
P	power dissipation	based on package heat transfer, not device power consumption	-	1.5	W

[1] The following applies to the Limiting values:

- Stresses above those listed under Limiting values may cause permanent damage to the device. This is a stress rating only and functional operation of the device at these or any conditions other than those described in Section 9 "Static characteristics" and Section 10 "Dynamic characteristics" of this specification is not implied.
- This product includes circuitry specifically designed for the protection of its internal devices from the damaging effects of excessive static charge. Nonetheless, it is suggested that conventional precautions be taken to avoid applying greater than the rated maxima.
- Parameters are valid over operating temperature range unless otherwise specified. All voltages are with respect to V_{SS} unless otherwise noted.

9. Static characteristics

Table 8: DC electrical characteristics

$T_{amb} = 0\text{ }^{\circ}\text{C}$ to $+70\text{ }^{\circ}\text{C}$ for commercial, unless otherwise specified; $V_{DD} = 4.5\text{ V}$ to 5.5 V unless otherwise specified.

Symbol	Parameter	Conditions	Min	Typ ^[1]	Max	Unit
V_{IL}	LOW-level input voltage		-0.5	-	$0.2V_{DD} - 0.1$	V
V_{IH}	HIGH-level input voltage (ports 0, 1, 2, 3, 4, \overline{EA})		$0.2V_{DD} + 0.9$	-	$V_{DD} + 0.5$	V
V_{IH1}	HIGH-level input voltage, XTAL1, RST		$0.7V_{DD}$	-	$V_{DD} + 0.5$	V
V_{OL}	LOW-level output voltage, ports 1, 2, 3, 4 ^[8]	$V_{DD} = 4.5\text{ V}$; $I_{OL} = 1.6\text{ mA}$	-	-	0.4	V
V_{OL1}	LOW-level output voltage, port 0, ALE, \overline{PSEN} ^{[7][8]}	$V_{DD} = 4.5\text{ V}$; $I_{OL} = 3.2\text{ mA}$	-	-	0.4	V
V_{OH}	HIGH-level output voltage, ports 1, 2, 3, 4	$V_{DD} = 4.5\text{ V}$; $I_{OH} = -30\text{ A}$	$V_{DD} - 0.7$	-	-	V
V_{OH1}	HIGH-level output voltage (port 0 in external bus mode), ALE ^[9] , \overline{PSEN} ^[3]	$V_{DD} = 4.5\text{ V}$; $I_{OH} = -3.2\text{ mA}$	$V_{DD} - 0.7$	-	-	V
I_{IL}	Logical 0 input current, ports 1, 2, 3, 4	$V_{IN} = 0.4\text{ V}$	-1	-	-75	μA
I_{TL}	Logical 1-to-0 transition current, ports 1, 2, 3, 4 ^[8]	$4.5\text{ V} < V_{DD} < 5.5\text{ V}$; $V_{IN} = 2.0\text{ V}$	^[4] -	-	-650	μA
I_{L1}	Input leakage current, port 0	$0.45 < V_{IN} < V_{DD} - 0.3$	-	-	± 10	μA
I_{CC}	Power supply current		^[5] -	-	-	
	Active mode ^[5]	$V_{DD} = 5.5\text{ V}$	-	-	$7 + 2.7 \times f_{osc}[\text{MHz}]$	mA
	Idle mode ^[5]		-	-	$4 + 1.3 \times f_{osc}[\text{MHz}]$	mA
	Power-down mode or clock stopped (see Figure 13 for conditions)		-	20	100	μA
R_{RST}	Internal reset pull-down resistor		40	-	225	k Ω
C_{10}	Pin capacitance ^[10] (except EA)		-	-	15	pF

[1] Typical ratings are not guaranteed. The values listed are at room temperature ($+25\text{ }^{\circ}\text{C}$), 5 V, unless otherwise stated.

[2] Capacitive loading on ports 0 and 2 may cause spurious noise to be superimposed on the V_{OL} of ALE and ports 1, 3 and 4. The noise is due to external bus capacitance discharging into the Port 0 and Port 2 pins when these pins make 1-to-0 transitions during bus operations. In the worst cases (capacitive loading $>100\text{ pF}$), the noise pulse on the ALE pin may exceed 0.8 V. In such cases, it may be desirable to qualify ALE with a Schmitt Trigger, or use an address latch with a Schmitt Trigger STROBE input. I_{OL} can exceed these conditions provided that no single output sinks more than 5 mA and no more than two outputs exceed the test conditions.

[3] Capacitive loading on ports 0 and 2 may cause the V_{OH} on ALE and \overline{PSEN} to momentarily fall below the $V_{DD} - 0.7\text{ V}$ specification when the address bits are stabilizing.

[4] Pins of ports 1, 2, 3 and 4 source a transition current when they are being externally driven from '1' to '0'. The transition current reaches its maximum value when V_{IN} is approximately 2 V for $4.5\text{ V} < V_{DD} < 5.5\text{ V}$.

[5] See [Figure 10](#) through [Figure 13](#) for I_{CC} test conditions. f_{osc} is the oscillator frequency in MHz.

[6] This value applies to $T_{amb} = 0\text{ }^{\circ}\text{C}$ to $+70\text{ }^{\circ}\text{C}$.

[7] Load capacitance for port 0, ALE, and $\overline{PSEN} = 100\text{ pF}$, load capacitance for all other outputs = 80 pF.

[8] Under steady state (non-transient) conditions, I_{OL} must be externally limited as follows:

- Maximum I_{OL} per port pin: 15 mA
- Maximum I_{OL} per 8-bit port: 26 mA

c) Maximum total I_{OL} for all outputs: 71 mA

If I_{OL} exceeds the test condition, V_{OL} may exceed the related specification. Pins are not guaranteed to sink current greater than the listed test conditions.

[9] ALE is tested to V_{OH1} , except when ALE is off then V_{OH} is the voltage specification.

[10] Pin capacitance is characterized but not tested.

10. Dynamic characteristics

Table 9: AC electrical characteristics

$T_{amb} = 0^{\circ}\text{C}$ to $+70^{\circ}\text{C}$ for commercial unless otherwise specified. Formulae including t_{CLCL} assume oscillator signal with 50/50 duty cycle.^{[1][2][3]}

Symbol	Figure	Parameter	4.5 V < V_{DD} < 5.5 V				Unit
			Variable clock ^[4]		$f_{OSC} = 24\text{ MHz}$ ^[4]		
			Min	Max	Min	Max	
f_{OSC}	5	Oscillator frequency	0	24	-	-	MHz
t_{CLCL}	5	Clock cycle	-	-	41.5	-	ns
t_{LHLL}	5	ALE pulse width	$t_{CLCL} - 15$	-	26	-	ns
t_{AVLL}	5, 6, 7	Address valid to ALE LOW	$0.5t_{CLCL} - 15$	-	5	-	ns
t_{LLAX}	5, 6, 7	Address hold after ALE LOW	$0.5t_{CLCL} - 15$	-	5	-	ns
t_{LLIV}	5	ALE LOW to valid instruction in	-	$2t_{CLCL} - 30$	-	53	ns
t_{LLPL}	5	ALE LOW to \overline{PSEN} LOW	$0.5t_{CLCL} - 12$	-	8	-	ns
t_{PLPH}	5	\overline{PSEN} pulse width	$1.5t_{CLCL} - 20$	-	42	-	ns
t_{PLIV}	5	\overline{PSEN} LOW to valid instruction in	-	$1.5t_{CLCL} - 35$	-	27	ns
t_{PXIX}	5	Input instruction hold after \overline{PSEN}	0	-	0	-	ns
t_{PXIZ}	5	Input instruction float after \overline{PSEN}	-	$0.5t_{CLCL} - 5$	-	15	ns
t_{AVIV}	5	Address to valid instruction in (non-Extended Addressing Mode)	-	$2.5t_{CLCL} - 30$	-	74	ns
t_{AVIV1}	5	Address (A16-A22) to valid instruction in (Extended Addressing Mode)	-	$1.5t_{CLCL} - 34$	-	28	ns
t_{PLAZ}	5	\overline{PSEN} LOW to address float	-	8	-	8	ns
Data Memory							
t_{RLRH}	6	\overline{RD} pulse width	$3t_{CLCL} - 20$	-	105	-	ns
t_{WLWH}	7	\overline{WR} pulse width	$3t_{CLCL} - 20$	-	105	-	ns
t_{RLDV}	6	\overline{RD} LOW to valid data in	-	$2.5t_{CLCL} - 40$	-	64	ns
t_{RHDX}	6	Data hold after \overline{RD}	0	-	0	-	ns
t_{RHDZ}	6	Data float after \overline{RD}	-	$t_{CLCL} - 15$	-	26	ns
t_{LLDV}	6	ALE LOW to valid data in	-	$4t_{CLCL} - 35$	-	131	ns
t_{AVDV}	6	Address to valid data in (non-Extended Addressing Mode)	-	$4.5t_{CLCL} - 30$	-	157	ns
t_{AVDV1}	6	Address (A16-A22) to valid data in (Extended Addressing Mode)	-	$3.5t_{CLCL} - 35$	-	110	ns
t_{LLWL}	6, 7	ALE LOW to \overline{RD} or \overline{WR} LOW	$1.5t_{CLCL} - 10$	$1.5t_{CLCL} + 20$	52	82	ns
t_{AVWL}	6, 7	Address valid to \overline{WR} or \overline{RD} LOW (non-Extended Addressing Mode)	$2t_{CLCL} - 5$	-	78	-	ns
t_{AVWL1}	6, 7	Address (A16-A22) valid to \overline{WR} or \overline{RD} LOW (Extended Addressing Mode)	$t_{CLCL} - 10$	-	31	-	ns

Table 9: AC electrical characteristics...continued

$T_{amb} = 0^{\circ}\text{C}$ to $+70^{\circ}\text{C}$ for commercial unless otherwise specified. Formulae including t_{CLCL} assume oscillator signal with 50/50 duty cycle.^{[1][2][3]}

Symbol	Figure	Parameter	4.5 V < V _{DD} < 5.5 V				Unit
			Variable clock ^[4]		f _{OSC} = 24 MHz ^[4]		
			Min	Max	Min	Max	
t _{QVWX}	7	Data valid to \overline{WR} transition	0.5t _{CLCL} – 15	-	5	-	ns
t _{WHQX}	7	Data hold after \overline{WR}	0.5t _{CLCL} – 11	-	9	-	ns
t _{QVWH}	7	Data valid to \overline{WR} HIGH	3.5t _{CLCL} – 10	-	135	-	ns
t _{RLAZ}	6	\overline{RD} LOW to address float	-	0	-	0	ns
t _{WHLH}	6, 7	\overline{RD} or \overline{WR} HIGH to ALE HIGH	0.5t _{CLCL} – 11	0.5t _{CLCL} + 10	9	30	ns
External Clock							
t _{CHCX}	9	HIGH time	16	t _{CLCL} – t _{CLCX}	16	-	ns
t _{CLCX}	9	LOW time	16	t _{CLCL} – t _{CHCX}	16	-	ns
t _{CLCH}	9	Rise time	-	4	-	4	ns
t _{CHCL}	9	Fall Time	-	4	-	4	ns
Shift Register							
t _{XLXL}	8	Serial port clock cycle time	6t _{CLCL}	-	250	-	ns
t _{QVXH}	8	Output data set-up to clock rising edge	5t _{CLCL} – 10	-	198	-	ns
t _{XHQX}	8	Output data hold after clock rising edge	t _{CLCL} – 15	-	26	-	ns
t _{XHDX}	8	Input data hold after clock rising edge	0	-	0	-	ns
t _{XHDV}	8	Clock rising edge to input data valid	-	5t _{CLCL} – 35	-	173	ns

[1] Parameters are valid over operating temperature range unless otherwise specified.

[2] Load capacitance for port 0, ALE, and \overline{PSEN} = 100 pF, load capacitance for all other outputs = 80 pF.

[3] Interfacing the microcontroller to devices with float times up to 45 ns is permitted. This limited bus contention will not cause damage to Port 0 drivers.

[4] Parts are tested down to 2 MHz, but are guaranteed to operate down to 0 Hz.

Table 10: I²C-bus interface characteristics

Symbol	Parameter	Conditions	Input	Output
t _{HD;STA}	START condition hold time		≥ 7t _{CLCL}	> 4.0 μs
t _{LOW}	SCL LOW time		≥ 8t _{CLCL}	> 4.7 μs
t _{HIGH}	SCL HIGH time		≥ 7t _{CLCL}	> 4.0 μs
t _{RC}	SCL rise time		≤ 1 μs	-
t _{FC}	SCL fall time		≤ 0.3 μs	< 0.3 μs
t _{SU;DAT1}	Data set-up time		≥ 250 ns	> 10t _{CLCL} - t _{RD}
t _{SU;DAT2}	SDA set-up time	before repeated START condition	≥ 250 ns	> 1 μs
t _{SU;DAT3}	SDA set-up time	before STOP condition	≥ 250 ns	> 4t _{CLCL}
t _{HD;DAT}	Data hold time		≥ 0 ns	> 4t _{CLCL} - t _{FC}
t _{SU;STA}	Repeated START set-up time		≥ 7t _{CLCL}	> 4.7 μs
t _{SU;STO}	STOP condition set-up time		≥ 7t _{CLCL}	> 4.0 μs
t _{BUF}	Bus free time		≥ 7t _{CLCL}	> 4.7 μs
t _{RD}	SDA rise time		≤ 1 μs	-
t _{FD}	SDA fall time		≤ 300 ns	< 0.3 μs

[1] Parameters are valid over operating temperature range unless otherwise specified.

[2] Load capacitance for port 0, ALE, and $\overline{\text{PSEN}}$ = 100 pF, load capacitance for all other outputs = 80 pF.

[3] Interfacing the microcontroller to devices with float times up to 45 ns is permitted. This limited bus contention will not cause damage to Port 0 drivers.

[4] Parts are tested down to 2 MHz, but are guaranteed to operate down to 0 Hz.

10.1 Explanation of AC symbols

Each timing symbol has five characters. The first character is always 't' (= time). The other characters, depending on their positions, indicate the name of a signal or the logical status of that signal. The designations are:

- A** — Address
- C** — Clock
- D** — Input data
- H** — Logic level HIGH
- I** — Instruction (program memory contents)
- L** — Logic level LOW, or ALE
- P** — $\overline{\text{PSEN}}$
- Q** — Output data
- R** — $\overline{\text{RD}}$ signal
- t** — Time
- V** — Valid
- W** — $\overline{\text{WR}}$ signal
- X** — No longer a valid logic level
- Z** — Float

Examples:

t_{AVLL} — Time for address valid to ALE LOW.

t_{LLPL} — Time for ALE LOW to \overline{PSEN} LOW.

10.2 Timing diagrams

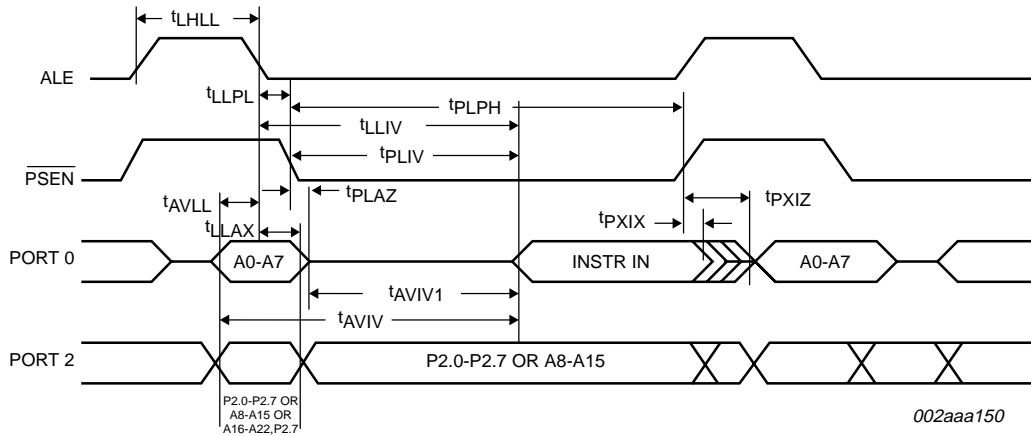

Fig 5. External program memory read cycle.

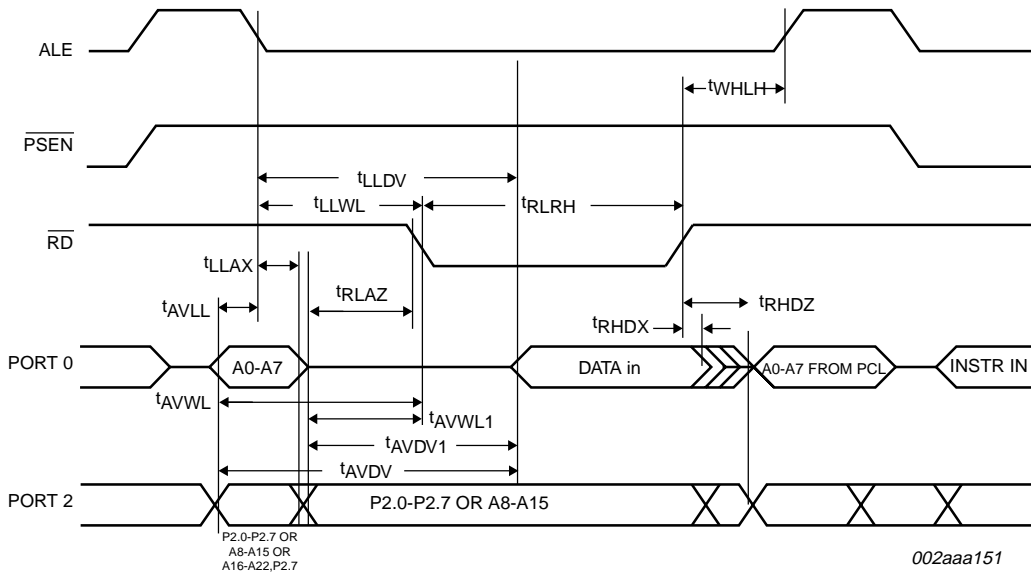
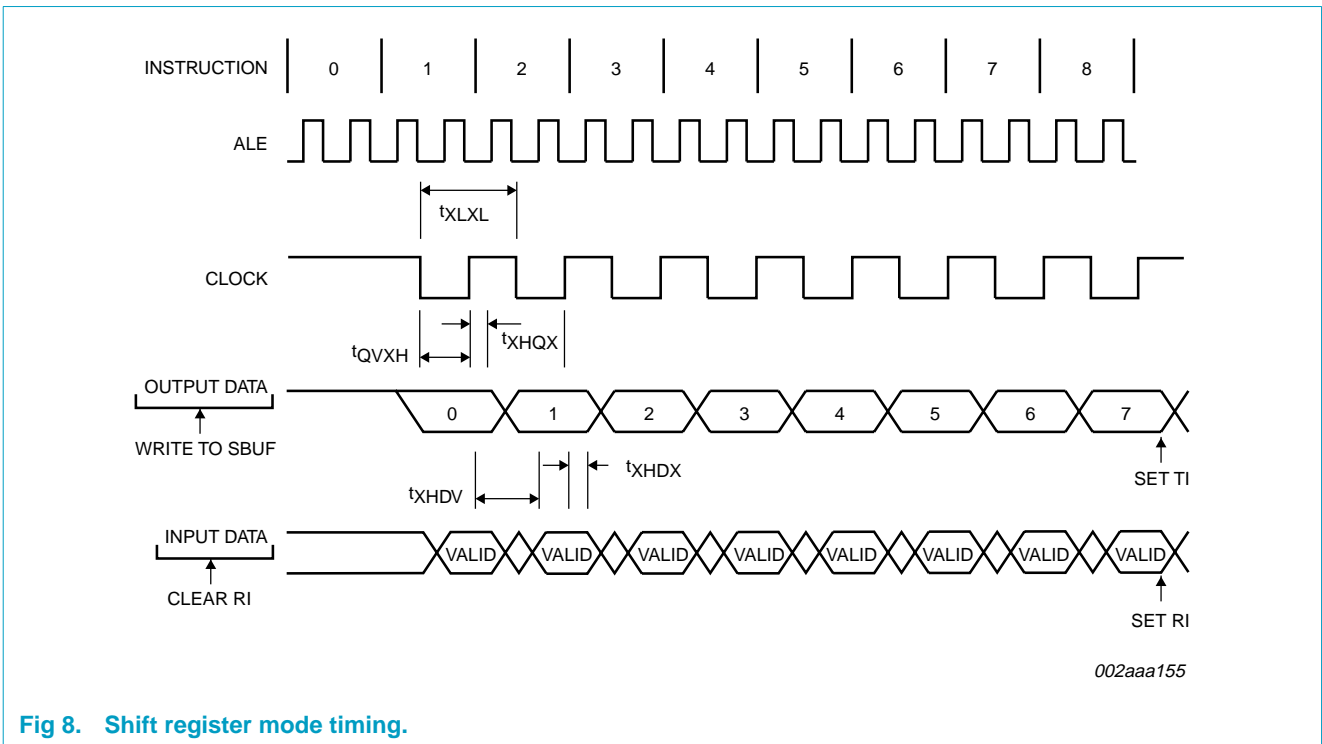
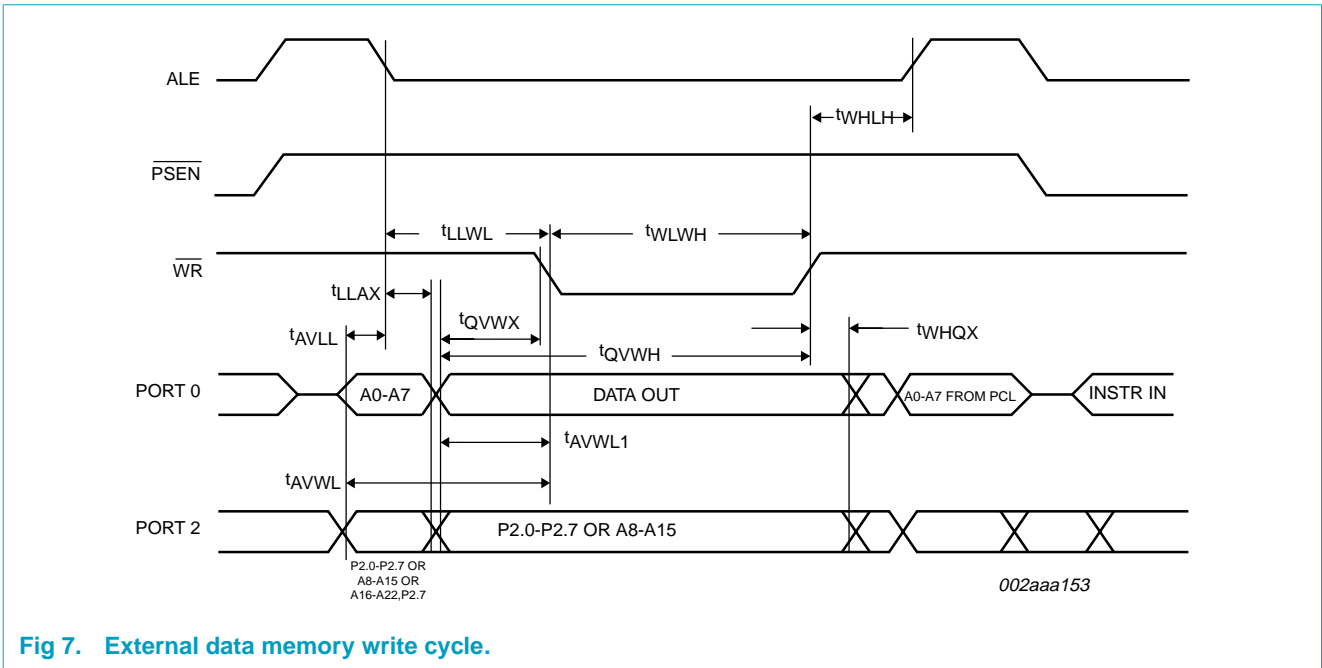

Fig 6. External data memory read cycle.



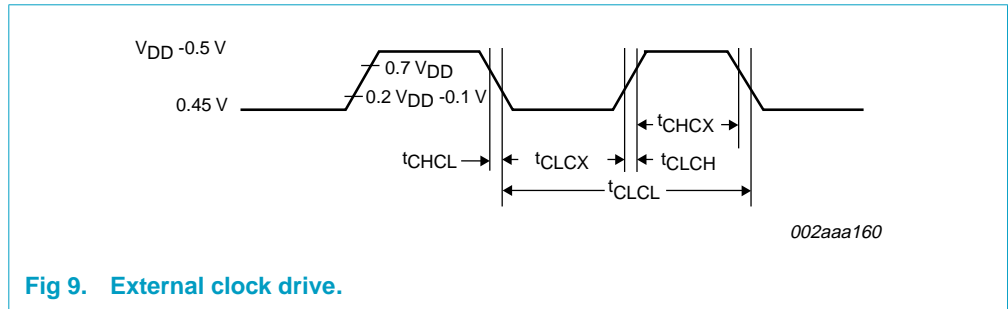

Fig 9. External clock drive.

11. Test information

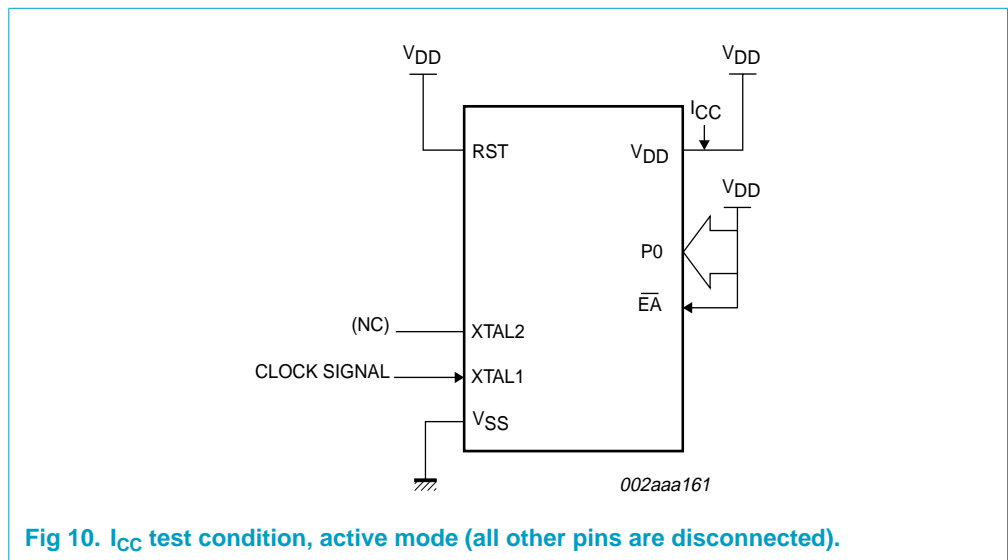

Fig 10. I_{CC} test condition, active mode (all other pins are disconnected).

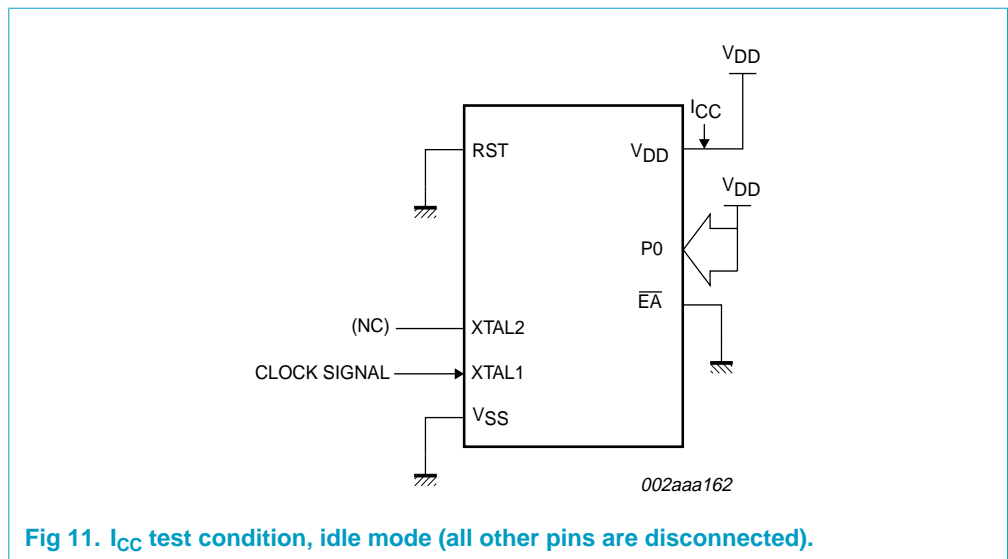
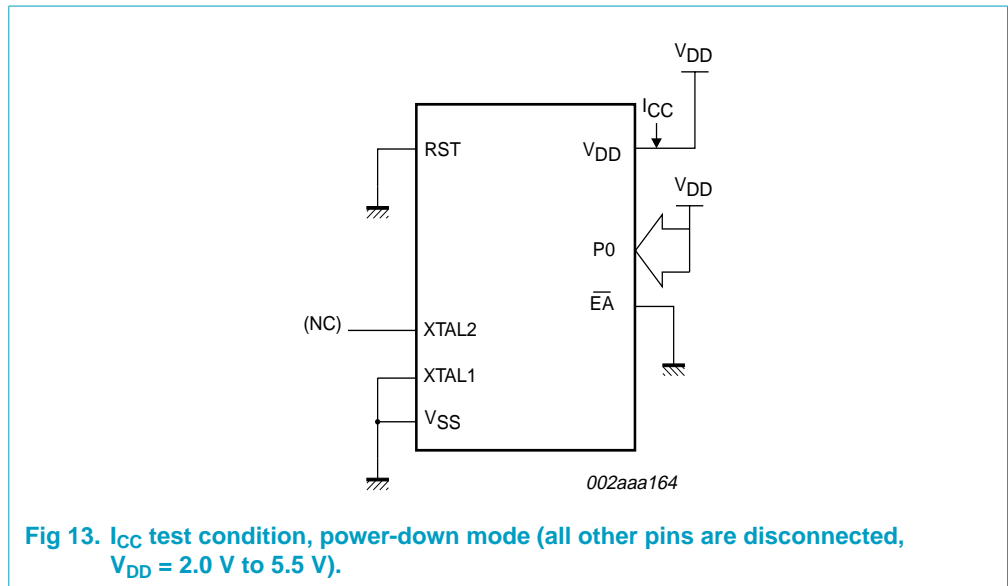
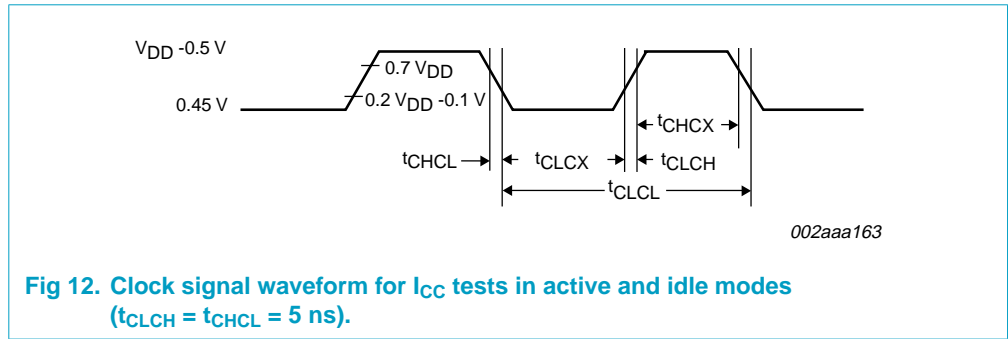

Fig 11. I_{CC} test condition, idle mode (all other pins are disconnected).



12. Package outline

PLCC44: plastic leaded chip carrier; 44 leads

SOT187-2

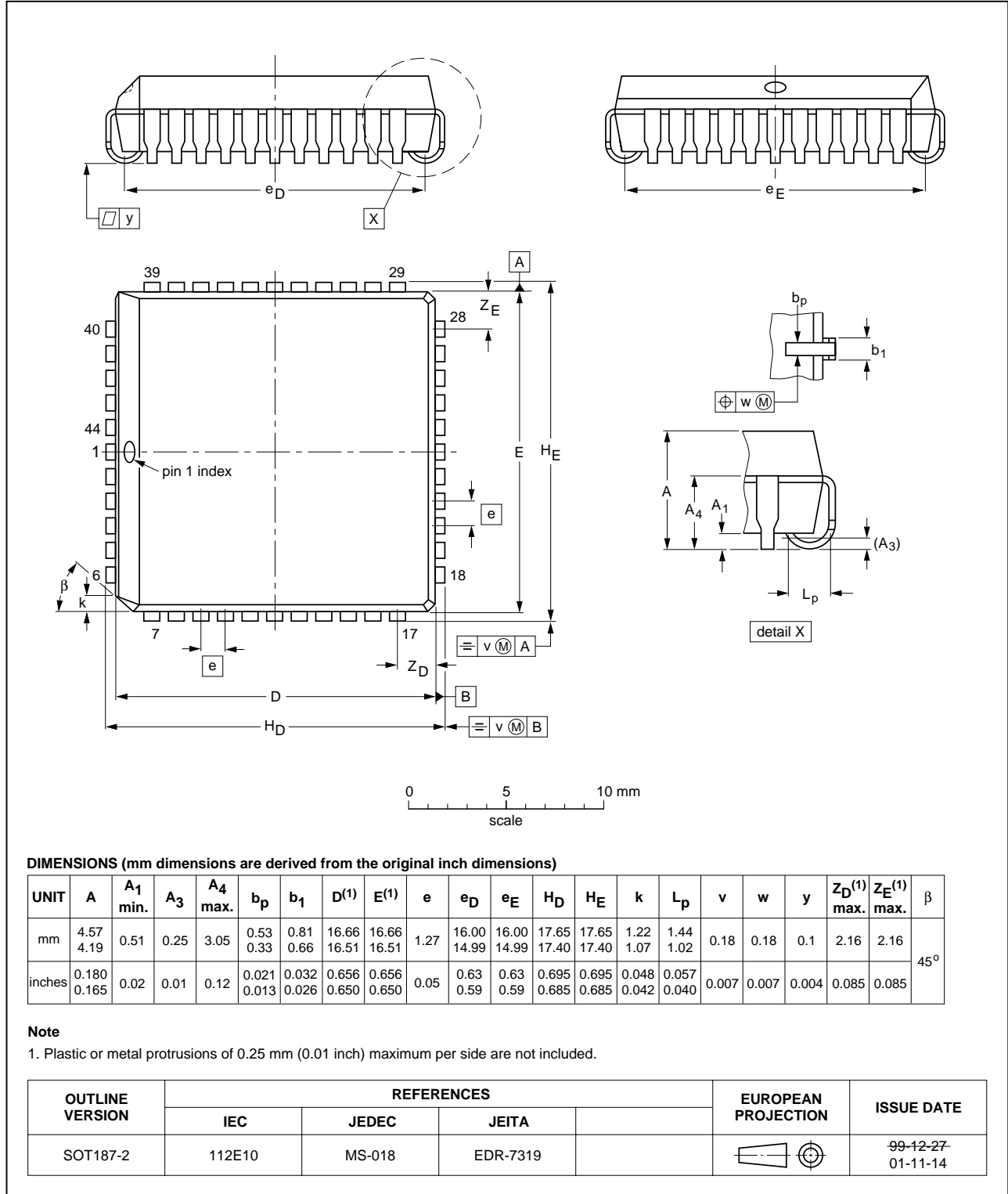

Fig 14. SOT187-2.

LQFP44: plastic low profile quad flat package; 44 leads; body 10 x 10 x 1.4 mm

SOT389-1

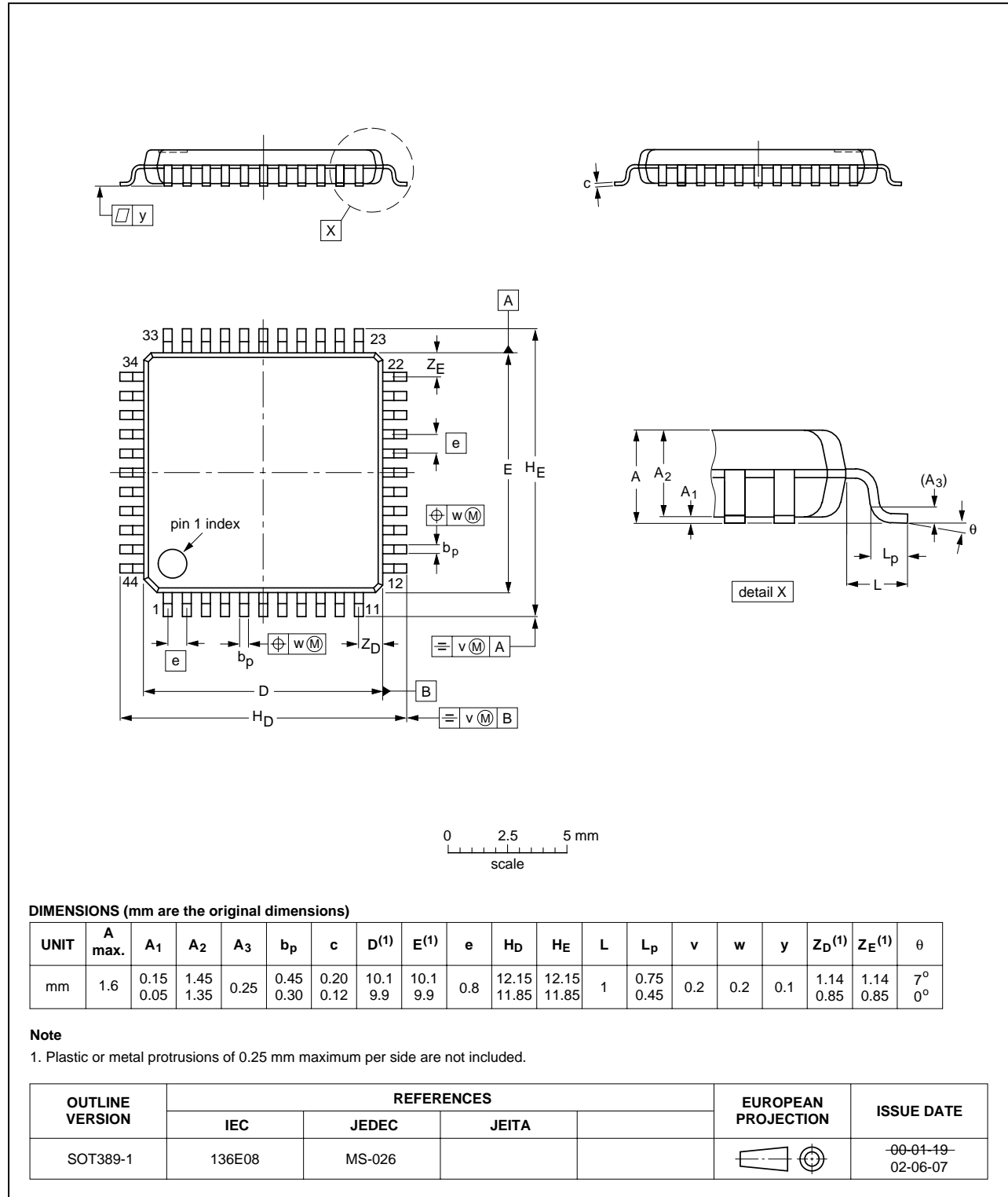

Fig 15. SOT389-1.

13. Soldering

13.1 Introduction to soldering surface mount packages

This text gives a very brief insight to a complex technology. A more in-depth account of soldering ICs can be found in our *Data Handbook IC26; Integrated Circuit Packages* (document order number 9398 652 90011).

There is no soldering method that is ideal for all IC packages. Wave soldering can still be used for certain surface mount ICs, but it is not suitable for fine pitch SMDs. In these situations reflow soldering is recommended. In these situations reflow soldering is recommended.

13.2 Reflow soldering

Reflow soldering requires solder paste (a suspension of fine solder particles, flux and binding agent) to be applied to the printed-circuit board by screen printing, stencilling or pressure-syringe dispensing before package placement. Driven by legislation and environmental forces the worldwide use of lead-free solder pastes is increasing.

Several methods exist for reflowing; for example, convection or convection/infrared heating in a conveyor type oven. Throughput times (preheating, soldering and cooling) vary between 100 and 200 seconds depending on heating method.

Typical reflow peak temperatures range from 215 to 270 °C depending on solder paste material. The top-surface temperature of the packages should preferably be kept:

- below 220 °C (SnPb process) or below 245 °C (Pb-free process)
 - for all the BGA packages
 - for packages with a thickness ≥ 2.5 mm
 - for packages with a thickness < 2.5 mm and a volume ≥ 350 mm³ so called thick/large packages.
- below 235 °C (SnPb process) or below 260 °C (Pb-free process) for packages with a thickness < 2.5 mm and a volume < 350 mm³ so called small/thin packages.

Moisture sensitivity precautions, as indicated on packing, must be respected at all times.

13.3 Wave soldering

Conventional single wave soldering is not recommended for surface mount devices (SMDs) or printed-circuit boards with a high component density, as solder bridging and non-wetting can present major problems.

To overcome these problems the double-wave soldering method was specifically developed.

If wave soldering is used the following conditions must be observed for optimal results:

- Use a double-wave soldering method comprising a turbulent wave with high upward pressure followed by a smooth laminar wave.

- For packages with leads on two sides and a pitch (e):
 - larger than or equal to 1.27 mm, the footprint longitudinal axis is **preferred** to be parallel to the transport direction of the printed-circuit board;
 - smaller than 1.27 mm, the footprint longitudinal axis **must** be parallel to the transport direction of the printed-circuit board.

The footprint must incorporate solder thieves at the downstream end.

- For packages with leads on four sides, the footprint must be placed at a 45° angle to the transport direction of the printed-circuit board. The footprint must incorporate solder thieves downstream and at the side corners.

During placement and before soldering, the package must be fixed with a droplet of adhesive. The adhesive can be applied by screen printing, pin transfer or syringe dispensing. The package can be soldered after the adhesive is cured.

Typical dwell time of the leads in the wave ranges from 3 to 4 seconds at 250 °C or 265 °C, depending on solder material applied, SnPb or Pb-free respectively.

A mildly-activated flux will eliminate the need for removal of corrosive residues in most applications.

13.4 Manual soldering

Fix the component by first soldering two diagonally-opposite end leads. Use a low voltage (24 V or less) soldering iron applied to the flat part of the lead. Contact time must be limited to 10 seconds at up to 300 °C.

When using a dedicated tool, all other leads can be soldered in one operation within 2 to 5 seconds between 270 and 320 °C.

13.5 Package related soldering information

Table 11: Suitability of surface mount IC packages for wave and reflow soldering methods

Package ^[1]	Soldering method	
	Wave	Reflow ^[2]
BGA, LBGA, LFBGA, SQFP, TFBGA, VFBGA	not suitable	suitable
DHVQFN, HBCC, HBGA, HLQFP, HSQFP, HSOP, HTQFP, HTSSOP, HVQFN, HVSON, SMS	not suitable ^[3]	suitable
PLCC ^[4] , SO, SOJ	suitable	suitable
LQFP, QFP, TQFP	not recommended ^{[4][5]}	suitable
SSOP, TSSOP, VSO, VSSOP	not recommended ^[6]	suitable

[1] For more detailed information on the BGA packages refer to the *(LF)BGA Application Note* (AN01026); order a copy from your Philips Semiconductors sales office.

[2] All surface mount (SMD) packages are moisture sensitive. Depending upon the moisture content, the maximum temperature (with respect to time) and body size of the package, there is a risk that internal or external package cracks may occur due to vaporization of the moisture in them (the so called popcorn effect). For details, refer to the Drypack information in the *Data Handbook IC26; Integrated Circuit Packages; Section: Packing Methods*.

- [3] These packages are not suitable for wave soldering. On versions with the heatsink on the bottom side, the solder cannot penetrate between the printed-circuit board and the heatsink. On versions with the heatsink on the top side, the solder might be deposited on the heatsink surface.
- [4] If wave soldering is considered, then the package must be placed at a 45° angle to the solder wave direction. The package footprint must incorporate solder thieves downstream and at the side corners.
- [5] Wave soldering is suitable for LQFP, QFP and TQFP packages with a pitch (e) larger than 0.8 mm; it is definitely not suitable for packages with a pitch (e) equal to or smaller than 0.65 mm.
- [6] Wave soldering is suitable for SSOP and TSSOP packages with a pitch (e) equal to or larger than 0.65 mm; it is definitely not suitable for packages with a pitch (e) equal to or smaller than 0.5 mm.

14. Revision history

Table 12: Revision history

Rev	Date	CPCN	Description
01	20030508	-	Product data (9397 750 11359); ECN 853-2422 29812 of 14 April 2003

15. Data sheet status

Level	Data sheet status ^[1]	Product status ^{[2][3]}	Definition
I	Objective data	Development	This data sheet contains data from the objective specification for product development. Philips Semiconductors reserves the right to change the specification in any manner without notice.
II	Preliminary data	Qualification	This data sheet contains data from the preliminary specification. Supplementary data will be published at a later date. Philips Semiconductors reserves the right to change the specification without notice, in order to improve the design and supply the best possible product.
III	Product data	Production	This data sheet contains data from the product specification. Philips Semiconductors reserves the right to make changes at any time in order to improve the design, manufacturing and supply. Relevant changes will be communicated via a Customer Product/Process Change Notification (CPCN).

[1] Please consult the most recently issued data sheet before initiating or completing a design.

[2] The product status of the device(s) described in this data sheet may have changed since this data sheet was published. The latest information is available on the Internet at URL <http://www.semiconductors.philips.com>.

[3] For data sheets describing multiple type numbers, the highest-level product status determines the data sheet status.

16. Definitions

Short-form specification — The data in a short-form specification is extracted from a full data sheet with the same type number and title. For detailed information see the relevant data sheet or data handbook.

Limiting values definition — Limiting values given are in accordance with the Absolute Maximum Rating System (IEC 60134). Stress above one or more of the limiting values may cause permanent damage to the device. These are stress ratings only and operation of the device at these or at any other conditions above those given in the Characteristics sections of the specification is not implied. Exposure to limiting values for extended periods may affect device reliability.

Application information — Applications that are described herein for any of these products are for illustrative purposes only. Philips Semiconductors make no representation or warranty that such applications will be suitable for the specified use without further testing or modification.

17. Disclaimers

Life support — These products are not designed for use in life support appliances, devices, or systems where malfunction of these products can reasonably be expected to result in personal injury. Philips Semiconductors

customers using or selling these products for use in such applications do so at their own risk and agree to fully indemnify Philips Semiconductors for any damages resulting from such application.

Right to make changes — Philips Semiconductors reserves the right to make changes in the products - including circuits, standard cells, and/or software - described or contained herein in order to improve design and/or performance. When the product is in full production (status 'Production'), relevant changes will be communicated via a Customer Product/Process Change Notification (CPCN). Philips Semiconductors assumes no responsibility or liability for the use of any of these products, conveys no licence or title under any patent, copyright, or mask work right to these products, and makes no representations or warranties that these products are free from patent, copyright, or mask work right infringement, unless otherwise specified.

18. Licenses

Purchase of Philips I²C components



Purchase of Philips I²C components conveys a license under the Philips' I²C patent to use the components in the I²C system provided the system conforms to the I²C specification defined by Philips. This specification can be ordered using the code 9398 393 40011.

Contact information

For additional information, please visit <http://www.semiconductors.philips.com>.

For sales office addresses, send e-mail to: sales.addresses@www.semiconductors.philips.com.

Fax: +31 40 27 24825

Contents

1	General description	1
2	Features	2
2.1	Key features	2
2.2	Key benefits	2
2.3	Complete features	2
3	Ordering information	3
3.1	Ordering options	3
4	Block diagram	4
5	Functional diagram	5
6	Pinning information	6
6.1	Pinning	6
6.1.1	Plastic leaded chip carrier	6
6.1.2	Plastic low profile quad flat package	7
6.2	Pin description	8
7	Functional description	11
7.1	Flash memory description	11
7.2	Memory arrangement	12
7.3	Special function registers	12
7.4	Security bits	17
8	Limiting values	17
9	Static characteristics	18
10	Dynamic characteristics	19
10.1	Explanation of AC symbols	21
10.2	Timing diagrams	22
11	Test information	24
12	Package outline	26
13	Soldering	28
13.1	Introduction to soldering surface mount packages	28
13.2	Reflow soldering	28
13.3	Wave soldering	28
13.4	Manual soldering	29
13.5	Package related soldering information	29
14	Revision history	31
15	Data sheet status	32
16	Definitions	32
17	Disclaimers	32
18	Licenses	32

© Koninklijke Philips Electronics N.V. 2003.
Printed in the U.S.A

All rights are reserved. Reproduction in whole or in part is prohibited without the prior written consent of the copyright owner.

The information presented in this document does not form part of any quotation or contract, is believed to be accurate and reliable and may be changed without notice. No liability will be accepted by the publisher for any consequence of its use. Publication thereof does not convey nor imply any license under patent- or other industrial or intellectual property rights.

Date of release: 08 May 2003

Document order number: 9397 750 11359



PHILIPS

Let's make things better.