

# 10BASE-T Transceiver

## GENERAL DESCRIPTION

The ML4658 10BASE-T Transceiver is a single chip cable line driver/receiver that provides all of the functionality required to implement both an internal and external IEEE 802.3 10BASE-T MAU. This part offers a standard IEEE 802.3 AU interface that allows it to directly connect to industry standard manchester encoder/decoder chips or to an AUI cable.

The ML4658 requires a minimal number of external components, and is compliant to the IEEE 802.3 10BASE-T standard. The differential current driven transmitter offers superior performance because of its highly symmetrical switching. This results in low RFI noise and low jitter.

The Transceiver easily interfaces to 100Ω unshielded twisted pair cable, 150Ω shielded twisted pair cable, or a range of other characteristic impedances by simply changing one external resistor. Jabber, Link Test, and SQE Test are fully integrated onto the chip with enable/disable options. A polarity detection status pin, which can drive an LED, is provided for receive data, and the ML4658 offers automatic polarity correction.

## FEATURES

- Complete implementation of IEEE 802.3 10BASE-T Medium Attachment Unit (MAU)
- Incorporates an AU interface for use in an external MAU or internal MAU
- Single 5V supply  $\pm 10\%$
- No crystal or clock input
- Current Driven Output for low RFI noise and low jitter
- Capable of driving 100Ω unshielded twisted pair cable or 150Ω shielded twisted pair cable
- Polarity detect status pin capable of driving an LED
- Automatic Polarity Correction
- On-chip Jabber logic, Link Test, and SQE test with enable/disable option
- Provides six network status LED output pins

## BLOCK DIAGRAM

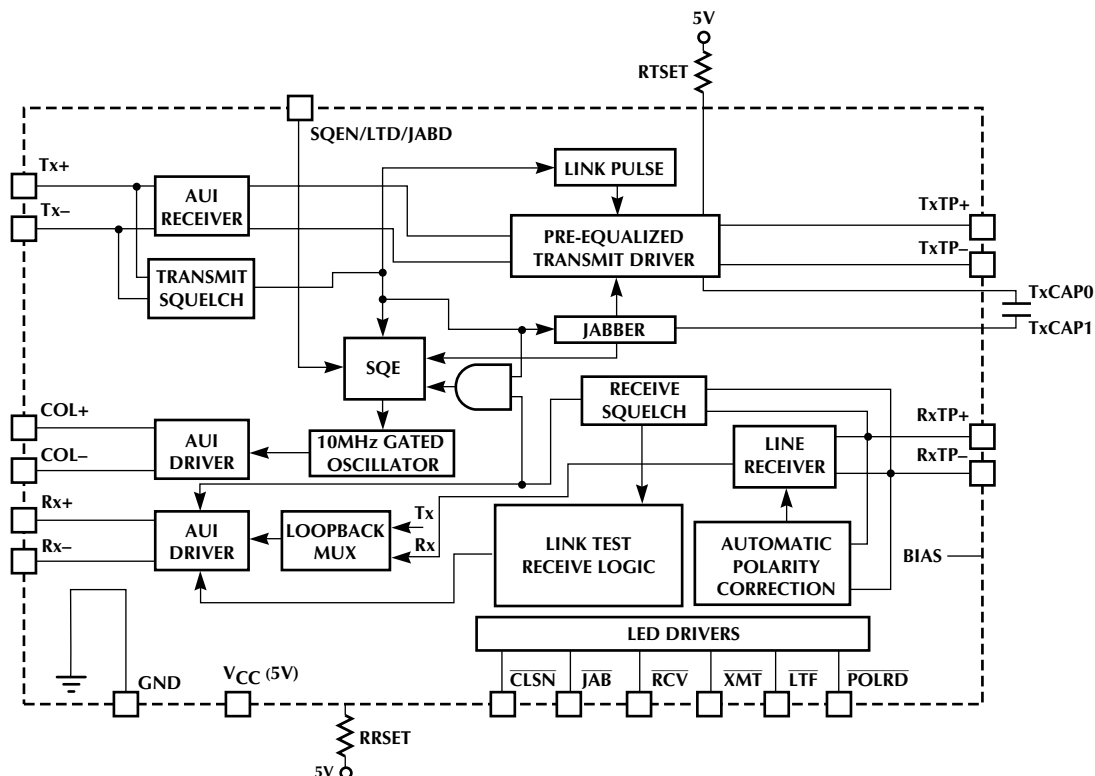

## PIN CONFIGURATION

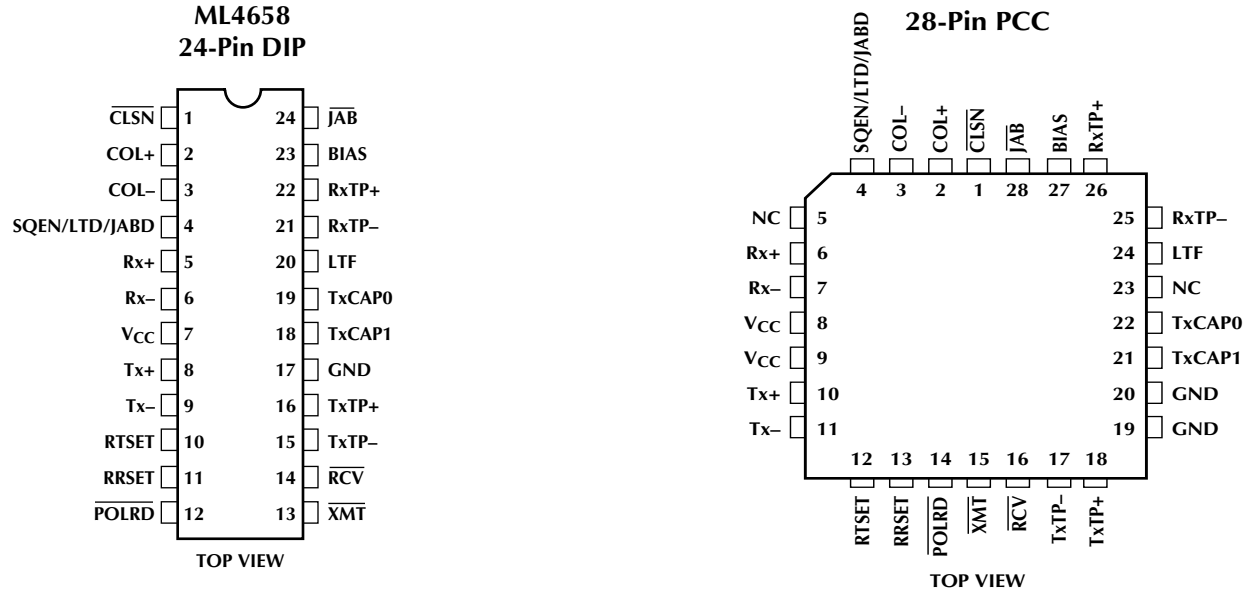

## PIN DESCRIPTION (DIP)

PIN#	NAME	FUNCTION
1	$\overline{\text{CLSN}}$	Indicates that a collision is taking place. Active low LED driver, open collector. Event is extended 100ms for visibility.
2	COL+	Gated 10MHz signal used to indicate a collision, SQE test, or jabber. Balanced differential line driver outputs that meet AU interface specifications. AC or DC coupled.
3	COL-	
4	SQEN/LTD/JABD	SQE Test Enable, Link Test Disabled, Jabber Disabled. This input uses four voltage levels to configure the chip as shown in Table 1.

**Table 1. SQEN/LTD/JABD Pin Configuration**

Pin	SQE Test	Link Test	Jabber
0V (GND)	Disabled	Enabled	Enabled
1.2V	Disabled	Disabled	Disabled
BIAS	Enabled	Disabled	Enabled
5V ( $V_{CC}$ )	Enabled	Enabled	Enabled

When link test is disabled, no link pulses are transmitted, and the transmitter and receiver will not be disabled as a result of a loss of receive link pulses. When Jabber is disabled the transmitter can transmit continuously without interruption, and the collision oscillator will not be activated.

5	Rx+	Manchester encoded receive data output to the local device. Balanced differential line driver outputs that meet AU interface specifications. AC or DC coupled.
6	Rx-	
7	$V_{CC}$	5 Volt power input.
8	Tx+	Balanced differential line receiver inputs that meet AU interface specifications. These inputs may be AC or DC coupled. When AC coupled, the BIAS pin is used to set the common mode voltage. Signals meeting the transmitter squelch input requirements are pre-equalized and output on TxTP+ and TxTP-.
9	Tx-	
10	RTSET	When using 100 $\Omega$ unshielded twisted pair, a 220 $\Omega$ resistor is tied between this pin and $V_{CC}$ . When using 150 $\Omega$ shielded twisted pair, a 330 $\Omega$ resistor is tied between this pin and $V_{CC}$ .
11	RRSET	A 1% 61.9K $\Omega$ resistor tied from this pin to $V_{CC}$ is used for internal biasing.

**PIN DESCRIPTION (DIP)** (Continued)

PIN#	NAME	FUNCTION
12	$\overline{\text{POLRD}}$	Receive Polarity status. Active low LED Driver, open collector output. Indicates the polarity of the receive twisted pair regardless of auto polarity correction. When this pin is high, the receive polarity is correct, and when this pin is low the receive polarity is reversed.
13	$\overline{\text{XMT}}$	Indicates that transmission is taking place on the TxTP+, TxTP- pair. Active low LED driver, open collector. It is extended 100ms for visibility.
14	$\overline{\text{RCV}}$	Indicates that the transceiver has unsquelched and is receiving data from the twisted pair. Active low LED driver, open collector. It is extended 100ms for visibility.
15	TxTP-	Pre-equalized differential balanced current driven output. These outputs are connected to a balanced transmit output filter which drives the twisted pair cable through pulse transformers. The output current is set with an external resistor connected to RTSET allowing the chip to drive 100 $\Omega$ unshielded twisted pair, 150 $\Omega$ shielded twisted pair cables or a range of other characteristic impedances.
16	TxTP+	
17	GND	Ground reference.
18	TxCAP1	An external capacitor of 330pF is tied between these two pins to set the pulse width for the pre-equalization on the transmitter. If these two pins are shorted together, no pre-equalization occurs.
19	TxCAP0	
20	LTF	Link Test Fail. Active high. Normally this pin is low, indicating that the link is operational. If the link goes down resulting from the absence of link pulses or frames being received, the chip will go into the Link Test Fail state and bring LTF high. In the Link Test Fail state, both the transmitter and receiver are disabled, however link pulses are still sent. A station that only has access to the AUI can detect a Link Test Fail by the absence of loopback. This pin is low when the Link Test is disabled. Open collector LED output.
21	RxTP-	Twisted Pair receive data input. When this signal exceeds the receive squelch requirements the receive data is buffered and sent to the Rx $\pm$ outputs.
22	RxTP+	
23	BIAS	Bias voltage, output. Used to bias the receive twisted pair inputs as well as the Tx $\pm$ inputs when they are AC coupled.
24	$\overline{\text{JAB}}$	Open collector TTL output capable of driving an LED. When in the Jabber state, this pin will be low and the transmitter will be disabled. In the Jabber "OK" state this pin will be high.

## ABSOLUTE MAXIMUM RATINGS (Note 1)

Power Supply Voltage Range	
$V_{CC}$ .....	-0.3 to 6V
Input Voltage Range	
Digital Inputs (SQEN, LTD) .....	-0.3 to $V_{CC}$
Tx+, Tx-, RxTP+, RxTP- .....	-0.3 to $V_{CC}$
Input Current	
RRSET, RTSET, $\overline{JAB}$ , $\overline{CLSN}$ , $\overline{XMT}$ , $\overline{RCV}$ , LTF .....	60mA
Output Current	
TxTP+, TxTP- .....	80mA
Storage Temperature .....	-65°C to 150°C
Lead Temperature (Soldering 10 sec.) .....	260°C

## OPERATING CONDITIONS

Supply Voltage ( $V_{CC}$ ) .....	5V $\pm$ 10%
LED on Current .....	10mA
RRSET .....	61.9k $\Omega$ $\pm$ 1%
RTSET .....	220 $\Omega$ $\pm$ 1%
TxCAP .....	330pF

## ELECTRICAL CHARACTERISTICS

Unless otherwise specified,  $T_A = 0^\circ\text{C}$  to  $70^\circ\text{C}$  (Note 3),  $V_{CC} = 5\text{V} \pm 10\%$  (Note 2)

PARAMETER	CONDITIONS	MIN	TYP	MAX	UNITS
Power Supply Current $I_{CC}$ (Note 4)	$V_{CC} = 5\text{V}$			140	mA
LED Drivers: $V_{OL}$	$R_L = 510\Omega$ (Note 5)			0.8	V
Transmit Peak Output Current	RTSET = 220 $\Omega$		42 (Note 6)		mA
Transmit Squelch Voltage Level (Tx+, Tx-)			-170		mV
Differential Input Voltage (RxTP+, RxTP-)		$\pm 0.300$		$\pm 3.1$	V
Receiver Input Resistance		10			k $\Omega$
SQEN/LTD/JABD Input Resistance			12		k $\Omega$
Receive Squelch Voltage Level (RxTP+, RxTP-)		300	450	585	mV-p
Differential Output Voltage (Rx $\pm$ , COL $\pm$ )		$\pm 550$		$\pm 1200$	mV
Common Mode Output Voltage (Rx $\pm$ , COL $\pm$ )			4.0		V
Differential Output Voltage Imbalance (Rx $\pm$ , COL $\pm$ )			2	$\pm 40$	mV
BIAS Voltage			3.2		V
SQEN/LTD/JABD	SQE TEST disabled All disabled Link Test Disabled All Enabled	1.1 BIAS - 0.15 $V_{CC} - 0.05\text{V}$		0.3 1.4 BIAS + 0.15	V

Note 1: Absolute maximum ratings are limits beyond which the life of the integrated circuit may be impaired. All voltages unless otherwise specified are measured with respect to ground.

Note 2: Limits are guaranteed by 100% testing, sampling, or correlation with worst-case test conditions.

Note 3: Low Duty cycle pulse testing is performed at  $T_A$ .

Note 4: This does not include the current from the AUI pull down resistors, the transmit pins TxTP+ and TxTP- or the LED output pins.

Note 5: LED drivers can sink up to 20mA, but  $V_{OL}$  will be higher.

Note 6: This current will result in a 2.5V peak output voltage on unshielded twisted pair cable when connected through an external filter and transformer as shown in Figure 12.

**ELECTRICAL CHARACTERISTICS** (Continued)**AC ELECTRICAL CHARACTERISTICS**

SYMBOL	PARAMETER	MIN	TYP	MAX	UNITS
<b>Transmit</b>					
t <sub>TXNPW</sub>	Transmit Turn-On Pulse Width		20		ns
t <sub>TXFPW</sub>	Transmit Turn-Off Pulse Width		180		ns
t <sub>TXLP</sub>	Transmit Loopback Startup Delay			200	ns
t <sub>TXODY</sub>	Tranmitter Turn-On Delay			200	ns
t <sub>TXSDY</sub>	Transmit Steady State Prop. Delay		15	100	ns
t <sub>TXJ</sub>	Transmitter Jitter		±2	±3.5	ns
<b>Receive</b>					
t <sub>RXODY</sub>	Receive Turn-On Delay if Transmit is Idle		420	500	ns
t <sub>RXTDY</sub>	Receive Turn-On Delay if Transmit is Active		650	800	ns
t <sub>RXFX</sub>	Last Bit Received to Start Slow Decay Output	230	800		ns
t <sub>RXSDY</sub>	Receive Steady State Prop. Delay		15	100	ns
t <sub>RXJ</sub>	Receiver Jitter		±0.7	±1.5	ns
t <sub>AR</sub>	Differential Output Rise Time 20% to 80% (Rx±, COL±)		3		ns
t <sub>AF</sub>	Differential Output Fall Time 20% to 80% (Rx±, COL±)		3		ns
<b>Collision</b>					
t <sub>CPSQE</sub>	Collision Present to SQE Assert	0		900	ns
t <sub>TXRX</sub>	Time for Loopback to switch from Tx to RxTP during a collision	0		900	ns
t <sub>SQEXR</sub>	Time for SQE to deactivate given that RxTP goes idle and TxTP continues	0		900	ns
t <sub>SQEXT</sub>	Time for SQE to deactivate given that TxTP goes idle and RxTP continues	0		900	ns
t <sub>CLF</sub>	Collision Frequency	8.5	10	11.5	MHz
t <sub>CLPDC</sub>	Collision Pulse Duty Cycle	40	50	60	%
t <sub>SQEDY</sub>	SQE Test Delay (Tx Inactive to SQE)	0.6	1.1	1.6	µs
t <sub>SQETD</sub>	SQE Test Duration	0.5	1.0	1.5	µs
<b>Jabber, Link Test and LED Timing</b>					
t <sub>JAD</sub>	Jabber Activation Delay	20	70	150	ms
t <sub>JRT</sub>	Jabber Reset Unjab Time	250	450	750	ms
t <sub>JSQE</sub>	Delay from Outputs Disabled to Collision Oscillator On		100		ns
t <sub>LLT</sub>	Link Loss Time	50	95	150	ms
t <sub>LTN</sub>	Link Test Pulse Receive Minimum Time	2	4.2	7	ms
t <sub>LTX</sub>	Link Test Pulse Receive Maximum Time	25	70	150	ms
t <sub>TLP</sub>	Link Test Pulse Repetition Rate	8	16	24	ms
t <sub>LTPW</sub>	Link Test Pulse Width	85	100	200	ns
t <sub>LEDT</sub>	XMT, RCV, CLSN On Time	30	100	300	ms

## TIMING DIAGRAMS

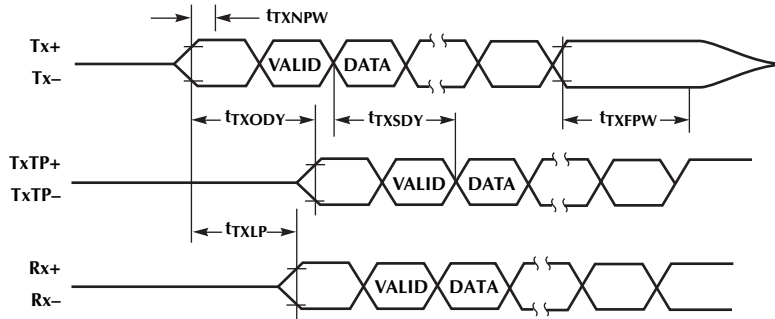

Figure 1. Transmit and Loopback Timing

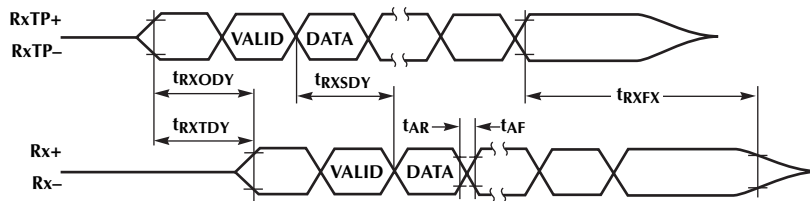

Figure 2. Receive Timing

TIMING DIAGRAMS (Continued)

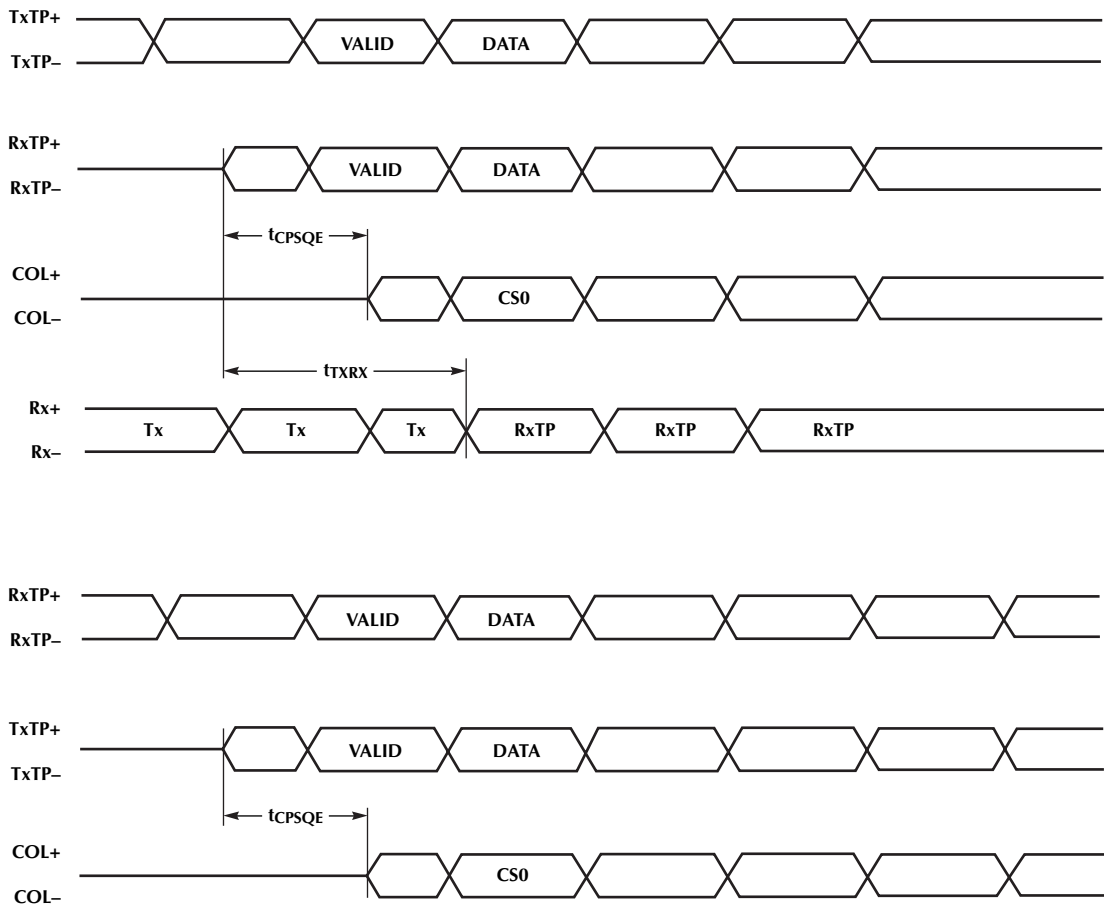

Figure 3. Collision Timing

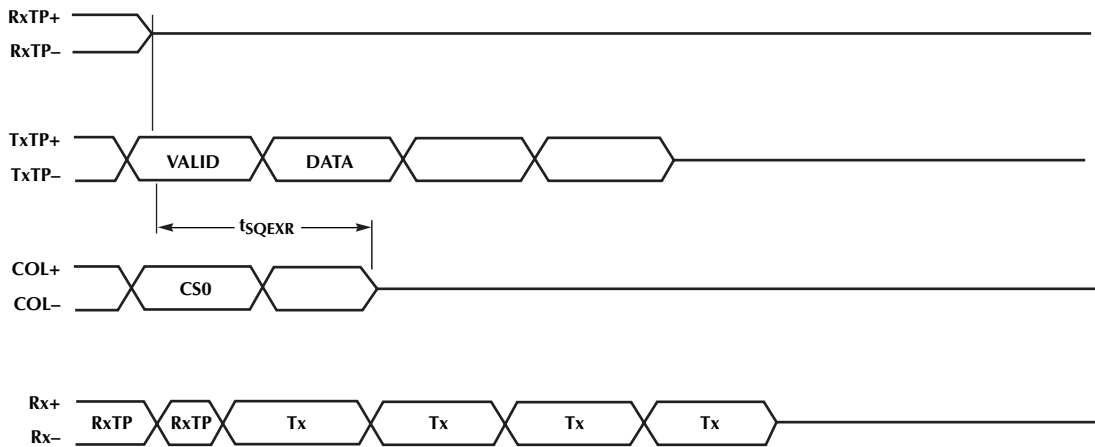

Figure 4. Collision Timing

## TIMING DIAGRAMS (Continued)

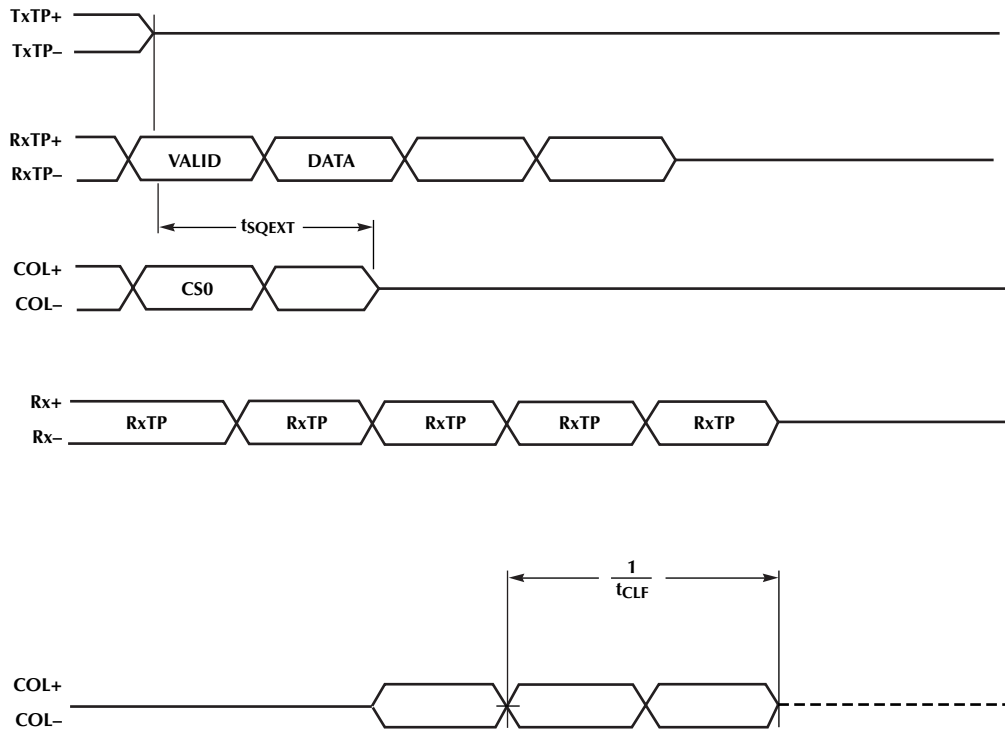

Figure 5. Collision Timing

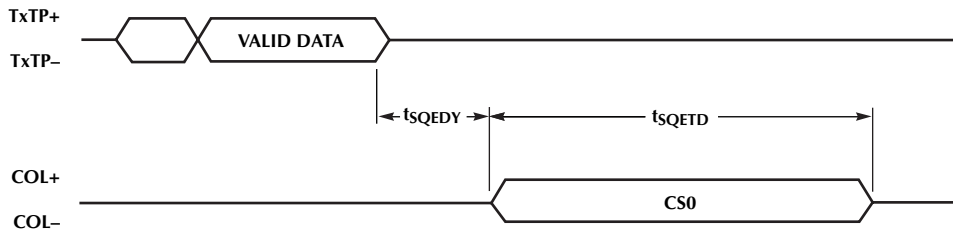

Figure 6. SQE Timing

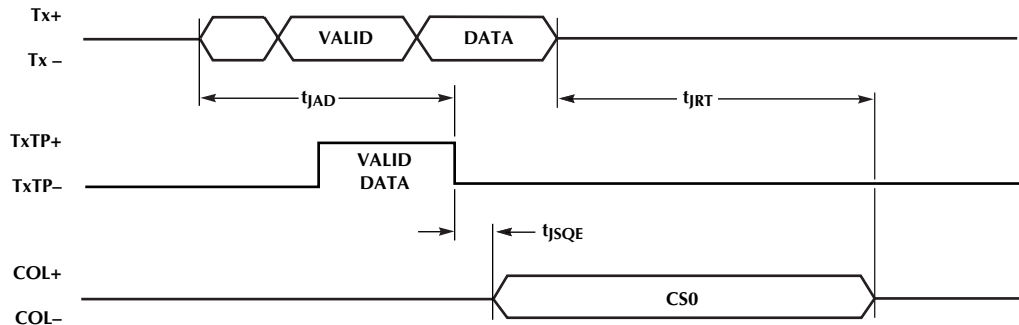

Figure 7. Jabber Timing



TIMING DIAGRAMS (Continued)

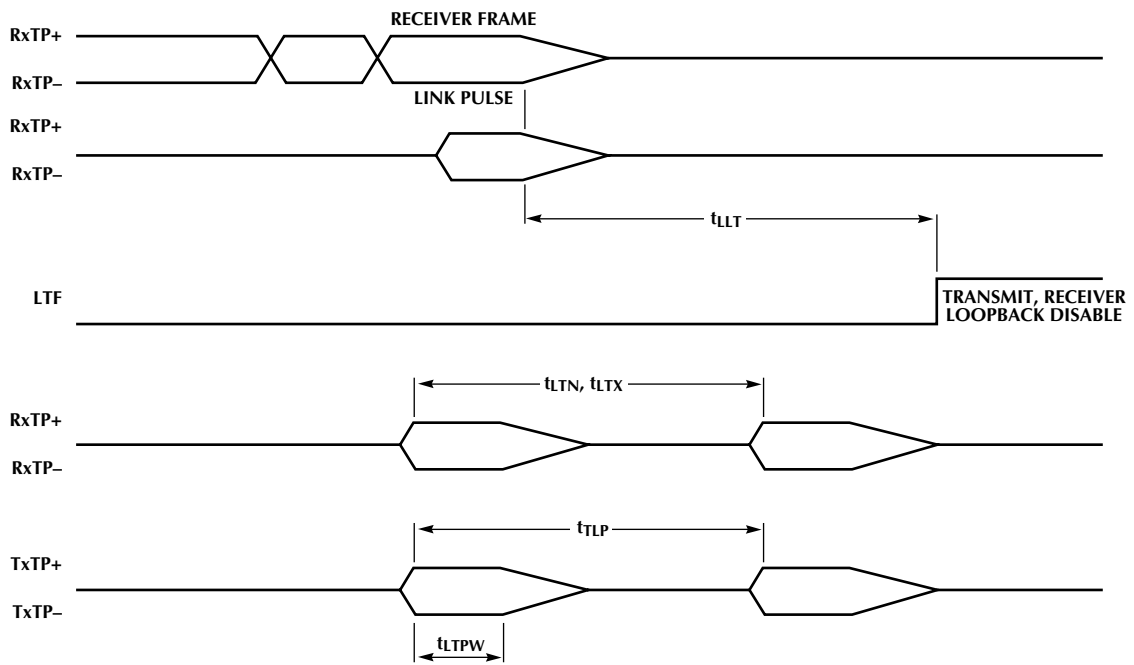

Figure 8. Link Pulse Timing

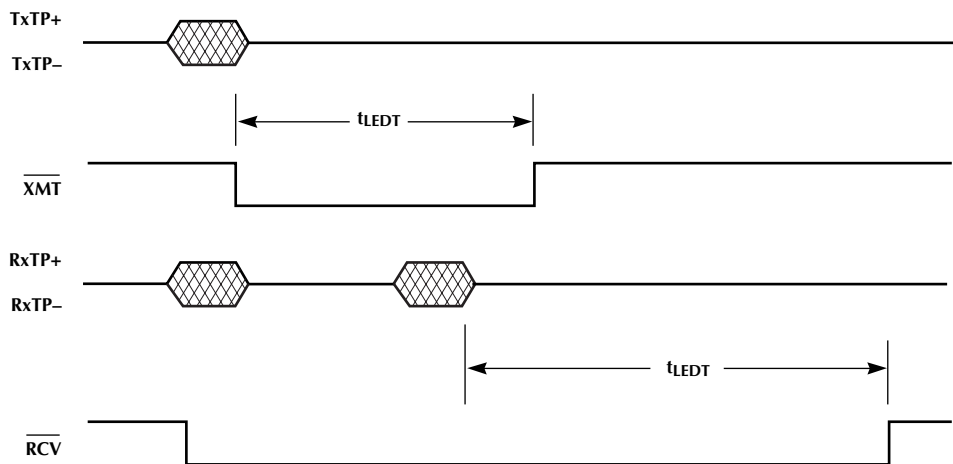

Figure 9. LED Timing

## SYSTEM DESCRIPTION

Figure 10 shows a typical block diagram of an external 10BASE-T transceiver interface. On one side of the transceiver is the AU interface and the other is the twisted pair. The AU interface is AC coupled when used in an external transceiver or can be AC or DC coupled when used in an internal transceiver. The AU interface for an external transceiver includes isolation transformers, some biasing resistors, and a voltage converter for power.

The twisted pair side of the transceiver requires external transmit and receive filters, isolation transformers, and terminating resistors. These components can be obtained in a single hybrid package from suppliers listed in Figure 12. The transmitter sends pre-equalized data through the transmit filters onto the twisted pair. The pre-equalized data uses a standard two step output waveform that lowers the amplitude of the 5MHz component so that at the receiving end both the 5MHz and 10MHz components have the same amplitude. The external transmit filter smooths the edges of the signal before passing it onto the twisted pair.

The receive pair side of the transceiver accepts the data after it passes through the isolation transformer and the receive low pass filter. Since this is an AC coupled input, the Bias pin is used to set the proper common mode voltage for the receive inputs. A pair of 50Ω resistors correctly terminate the receive pair and provide a common mode for the Bias voltage connection point.

## AU INTERFACE

The AU interface consists of 3 pairs of signals, DO, CI and DI, as shown in Figure 10. The DO pair contains transmit data from the DTE which is received by the transceiver and sent out onto the twisted pair. The DI pair contains valid data that has been either received from the twisted pair or looped back from the DO and output through the DI pair to the DTE. The CI pair indicates whether a transmit based collision has occurred. It is an output that oscillates at 10MHz. CI pair is also used for Jabber and SQE Test.

The transceiver may be AC or DC coupled depending on the application. For the AC coupled interface, the DO input must be DC biased (shifted up in voltage) for the proper common mode input voltage. The BIAS pin serves this purpose. When DC coupled, the manchester encoder/decoder transmit output pair provides this common mode voltage and the Bias pin is not connected.

The two 39Ω 1% resistors tied to the Tx+ and Tx- pins serve two purposes. They provide a point to connect the common mode bias voltage, and they provide the proper matching termination for the AUI cable. The CI and DI pair, which are output drivers from the transceiver to the AUI cable, require 360Ω pull down resistors when terminated with a 78Ω load. However on a DTE card, CI and DI do not need 78Ω terminating resistors. This also means that the pull down resistors on CI and DI can be 1kΩ or greater depending upon the particular manchester encoder/decoder chip used.

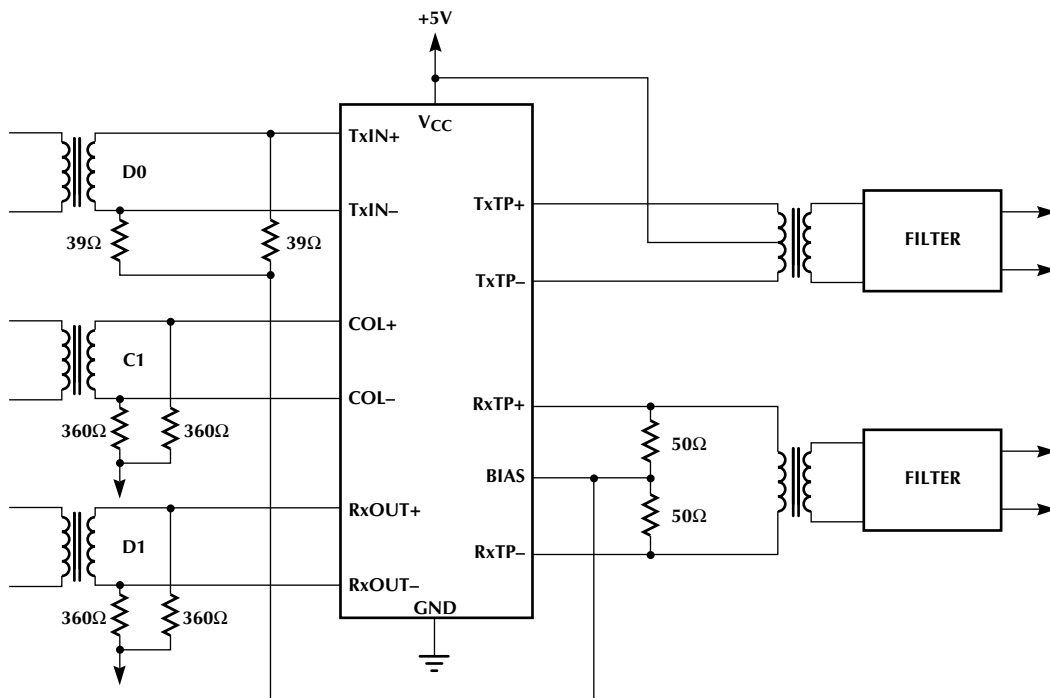

Figure 10. System Block Diagram

## SYSTEM DESCRIPTION (Continued)

The AUI drivers are capable of driving the full 50 meters of cable length and have a rise and fall time of typically 3ns. The rise and fall times match to within 1ns. In the idle state, the outputs go to the same voltage to prevent DC standing current in the isolation transformers.

### TRANSMISSION

The transmit function consists of detecting the presence of data from the AUI DO input (Tx+, Tx-) and driving that data onto the transmit twisted pair (TxTP+, TxTP-). A positive signal on the Tx+ lead relative to the Tx- lead of the DO circuit will result in a positive signal on the TxTP+ lead of the chip with respect to the TxTP- lead.

Before data will be transmitted onto the twisted pair from the AU interface, it must exceed the squelch requirements for the DO pair. The Tx squelch circuit serves the function of preventing any noise from being transmitted onto the twisted pair. This circuit rejects signals with pulse widths less than typically 20ns and voltage levels more positive than -175mV. Once the Tx squelch circuit has unsquelched, it looks for the start of idle signal to turn on the squelch circuit again. The transmitter turns on the squelch again when it receives an input signal at Tx± that is more positive than -175mV for more than approximately 180ns.

At the start of a packet transmission, no more than 2 bits are received from the DO circuit and not transmitted onto the twisted pair. The difference between start-up delays (bit loss plus steady-state propagation delay) for any two packets that are separated by 9.6µs or less will not exceed 200ns.

The output stage of the transmitter is a current mode switch which develops the output voltage by driving current through the terminating resistor and the output filter. The transmitter employs a center tap 2:1 transformer where the center tap is tied to V<sub>CC</sub> (5V). While one pin of the transmit pair (TxTP+, TxTP-) is pulled low, the other pin floats. The output pins to the twisted pair wires, TxTP+ and TxTP-, can drive a 100Ω, 150Ω load, or a variety of impedances that are characteristic of the twisted pair wire. RTSET selects the current into the TxTP+, TxTP- pins. This current along with the characteristic impedance of the cable determines the output voltage.

Once the characteristic impedance of the twisted pair is determined, one must select the appropriate RTSET resistor as well as match the terminating impedances of the transmit and receive filter. The RTSET resistor can be selected as follows:

$$RTSET = (R_L / 100) \times 220\Omega$$

where  $R_L$  is the characteristic impedance of the twisted pair cable.

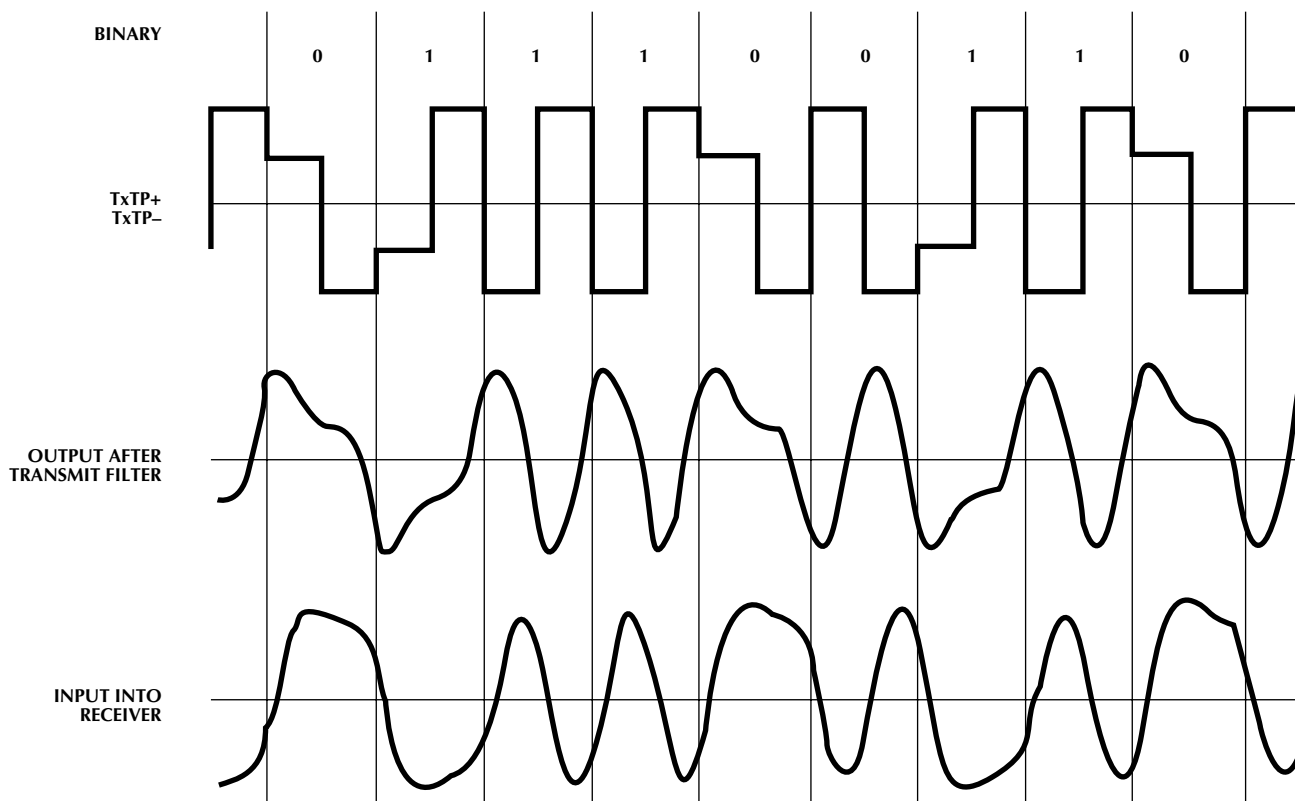

Figure 11. Transmit Pre-Equalization Waveform

## SYSTEM DESCRIPTION (Continued)

The transmitter incorporates a pre-equalization circuit for driving the twisted pair line. Pre-equalization compensates for the amplitude and phase distortion introduced by the twisted pair cable. The twisted pair line will attenuate the 10MHz signal more than the 5MHz signal. Therefore pre-equalization insures that both the 5 and 10MHz components will be roughly the same amplitude at the far end receiver.

The pre-equalization circuit reduces the current output when a 5MHz bit is being transmitted. After 50ns of a 5MHz bit, the current level is reduced to approximately 2/3 of its peak for the remaining 50ns. Figure 11 illustrates the pre-equalization.

An on-chip one-shot determines the pulse width of the pre-equalized transmit signal. This requires an external capacitor connected to pins TxCAP0 and TxCAP1. The proper value for this one-shot is 330pF. Pre-equalization can be disabled by shorting TxCAP0 and TxCAP1 together.

The transmitter enters the idle state when it detects start of idle on Tx+ and Tx- input pins. The transmitter maintains a minimum differential output voltage of at least 450mV for 250ns after the last low to high transition. The driver differential output voltage will then be within 50mV of 0V within 45 bit times.

### RECEPTION

The twisted pair receive data is transformer coupled and low pass filtered before it is fed into the input pins RxTP±. The input is differential with the common mode voltage set by the chip's Bias pin. At the start of packet reception from the twisted pair link, no more than 5 bits are received from the twisted pair cable and not transmitted onto the DI circuit. The first bit sent on the DI circuit may contain phase violations or invalid data, but all subsequent bits are valid.

The receive squelch will reject the following signals on the RxTP+ and RxTP- inputs:

1. All signals that produce a peak magnitude less than 300mV.
2. All continuous sinusoidal signals of amplitude less than  $6.2V_{P-P}$  and frequency less than 2MHz.
3. All single sinusoidal cycles of amplitude less than  $6.2V_{P-P}$  and either polarity, where the frequency is between 2MHz and 15MHz. For a period of 4 BT before and after this single cycle, the signal will conform to (1) above.
4. All sinusoidal cycles gated by a 100ns pulse gate of amplitude less than  $6.2V_{P-P}$  and either polarity, where the sinusoidal frequency is between 2MHz and 30MHz. The off time of the pulse gate on the sinusoidal signal shall be at least 400ns.

The first three receive squelch criteria are required to conform to the 10BASE-T standard. The fourth receive squelch criteria exceeds the 10BASE-T requirements and enhances the performance of the receiver. The fourth squelch criteria prevents a false unsquelch caused by cross talk or noise typically found coupling from the phone lines onto the receive twisted pair.

When the receive squelch is on during idle, the input voltage must exceed approximately  $\pm 450mV$  peak several times before unsquelch occurs. If the transmitter is inactive, the receiver has up to 5 bit times to unsquelch and output the receive data on the Rx+, Rx- pair. If the transmitter is active, the receive squelch extends the time it takes to determine whether to unsquelch. If the receiver unsquelches while the transmitter is active, a collision will result. Therefore the receive squelch uses the additional time to insure that a collision will not be reported as a result of a false receive squelch.

After the receiver is unsquelched, the detection threshold is lowered to 275mV. Upon passing the receive squelch requirements the receive data propagates into the multiplexer and eventually passes to the Rx+ and Rx- outputs of the AU interface. The addition of jitter through the receive section is no more than  $\pm 1.5ns$ .

While in the unsquelch state, the receive squelch circuit looks for the start of idle signal at the end of the packet. When start of idle is detected, receive squelch is turned on again. The proper start of idle occurs when the input signal remains above 300mV for 160ns. Nevertheless, if no transitions occur for 160ns, receive squelch is still turned on.

### COLLISION

Whenever the receiver and the transmitter are active at the same time the chip will activate the collision output. The collision output is a differential square wave matching the AUI specifications and capable of driving a  $78\Omega$  load. The frequency of the square wave is 10MHz  $\pm 15\%$  with a 60/40 to 40/60 duty cycle. The collision oscillation turns on no more than 9 bit times after the collision condition begins, and turns off no more than 9 bit times after the collision condition is removed. The collision oscillator also is activated during SQE Test and Jabber.

### LOOPBACK

The loopback function emulates a coax Ethernet transceiver where the transmit data sent by the DTE is looped back over the AUI receive pair. Many LAN controllers report the status of the carrier sense for each packet transmitted. The software can use this loopback information to determine whether a MAU is connected to the DTE by checking the status of carrier sense after each packet transmission.

## SYSTEM DESCRIPTION (Continued)

When data is received by the chip while transmitting, a collision condition exits. This will cause the collision oscillator to turn on within 9 bit times. The data on the DI/AUI pair (Rx+, Rx-) changes from Tx+, Tx- to RxTP+, RxTP-, when entering the collision state. During a collision, if the receive data (RxTP+, RxTP-) drops out before the transmit data (Tx+, Tx-), Rx+, Rx- will switch back to Tx+, Tx-.

### SQE TEST FUNCTION (SIGNAL QUALITY ERROR)

The SQE test function allows the DTE to determine whether the collision detect circuitry is functional. After each transmission, during the inter-packet gap time, the collision oscillator will be activated for typically 1 $\mu$ s. The SQE test will not be activated if the chip is in the link fail state, or the Jabber state.

For SQE to operate, the SQEN pin must be tied to V<sub>CC</sub> or BIAS. The SQE test can be disabled by tying the SQEN pin to 1.2V or ground. This allows the chip to be interfaced to a repeater.

### JABBER FUNCTION

The Jabber function prevents a babbling transmitter from bringing down the network. Within the transceiver is a Jabber timer that starts at the beginning of each transmission and resets at the end of each transmission. If the transmission lasts longer than 20ms the jabber logic disables the transmitter, and turns on the collision oscillator COL+, COL-. When Tx+ and Tx- finally go idle, a second timer measures 0.5 seconds of idle on Tx+ and Tx- before re-enabling the transmitter and turning off the collision oscillator. If transmission starts up again before 0.5 seconds has expired, the timer is reset and measures another 0.5 seconds of idle time.

Even though the transmitter is disabled during jabber, Link Pulses are still transmitted if the, Link Test is enabled.

Jabber can be disabled by placing 1.2V on the SQEN/LTD/JABD pin. This is useful for measuring jitter performance on the transmitter.

### LINKTEST FUNCTION

**Transmission** — Whenever data is not being delivered to the twisted pair link, the idle signal is applied. The idle signal is a sequence of Link Pulses separated by a 16ms period of silence. The idle signal starts with a period of silence after a packet transmission ends. The link test pulse is a single high pulse with the same amplitude requirements as the data signal.

**Reception** — The transceiver monitors the receive twisted pair input for packet and link pulse activity. If neither a packet nor a link test pulse is received for 50 to 150ms, the transceiver enters the Link Test Fail state and inhibits transmission and reception. Link pulses received with the wrong polarity will be ignored and cause the chip to go into link test fail.

A DTE can determine that the transceiver is in Link Test Fail one of two ways: it can monitor the LTF pin if the transceiver is internal, or it can monitor loopback. If the MAU is on-board the LTF pin can be sampled to determine that the transceiver is in the link fail state. If the MAU is external the DTE can monitor carrier sense during transmission. A loss of carrier sense is an indication of Link Test Fail State, since in Link Test Fail, loopback is disabled. Note that jabber also disables loopback but with Jabber the collision signal will be on.

When a packet, or two consecutive link test pulses is received from the twisted pair input, the transceiver will exit the Link Test Fail state upon transmit and receive data being idle, and re-enable transmission and reception.

Link test pulses that do not occur within at most 25 to 150ms of each other are not considered consecutive. In addition, detected pulses that occur within a time between 2 to 7ms of a previous pulse will be considered as noise by the link test circuitry.

### POLARITY CIRCUITRY

The ML4658 offers automatic polarity correction. The POLRD pin is used to report the status of the receive pair polarity. This pin reflects the true status of the receive polarity regardless of whether the part has autopolarity correction or not.

**Automatic Polarity Correction** — ML4658 — In the link OK state, receive polarity is updated when two consecutive frames are received with the same Start of Idle polarity. In the Link Test Fail state the part will use either the Start of Idle signal or link pulses to correct the receive polarity.

In the case where the part is powered up with the receive polarity reversed and no frames are received, the part will go into Link Test Fail. After two link pulses are received with the same polarity, the part will exit Link Test Fail and correct the receive polarity. The POLRD pin will continue to reflect the true polarity of the receive pair.

### LED DRIVERS

The ML4658 has six LED drivers for transmit, receive, collision, Link Test Fail, reverse polarity, and jabber. The LEDs are normally off except for LTF which is normally on and active high. The LEDs are tied to their respective pins through a 510 $\Omega$  resistor to 5 Volts.

The  $\overline{XMT}$ ,  $\overline{RCV}$  and  $\overline{CLSN}$  pins have pulse stretchers on them which enables the LEDs to be visible. When transmission or reception occurs, the LED  $\overline{XMT}$ ,  $\overline{RCV}$  or  $\overline{CLSN}$  status pins will activate low for 100ms. If another transmit, receive or collision condition occurs during the first 100ms, the LED timer will reset and begin timing again for 100ms. The LEDs will remain on for consecutive frames. The JAB, POLRD, and LTF LEDs do not have pulse stretchers on them since their conditions occur long enough for the eye to see.

## APPLICATION: EXTERNAL MAU

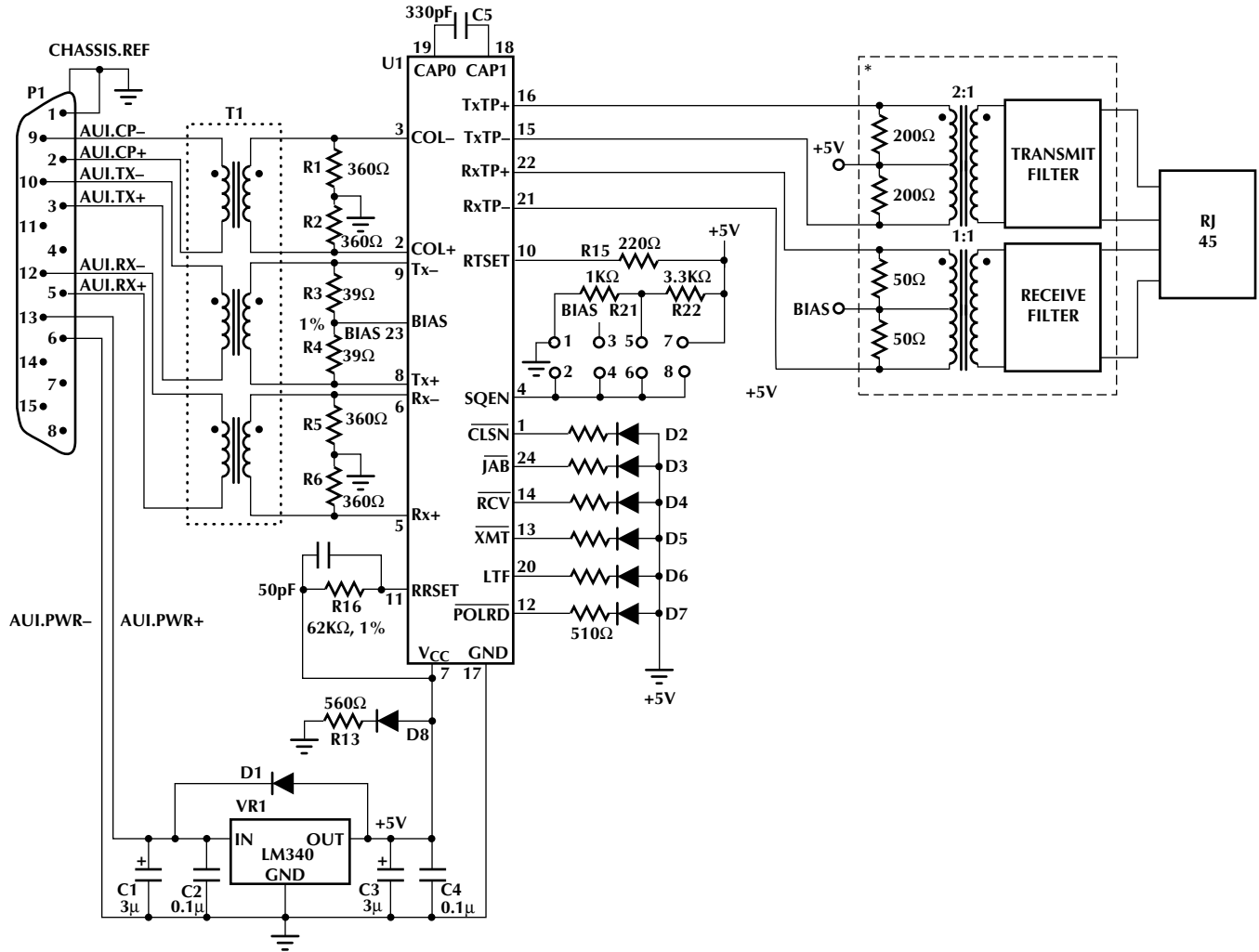

\* Single Chip Solutions are Available from Magnetic Suppliers.

Magnetics and Filter Suppliers:  
Pulse Engineering, Inc. (San Diego)  
Valor Electronics, Inc. (San Diego)  
Fil-Mag (San Diego)

Figure 12. External MAU

APPLICATION: INTERNAL MAU

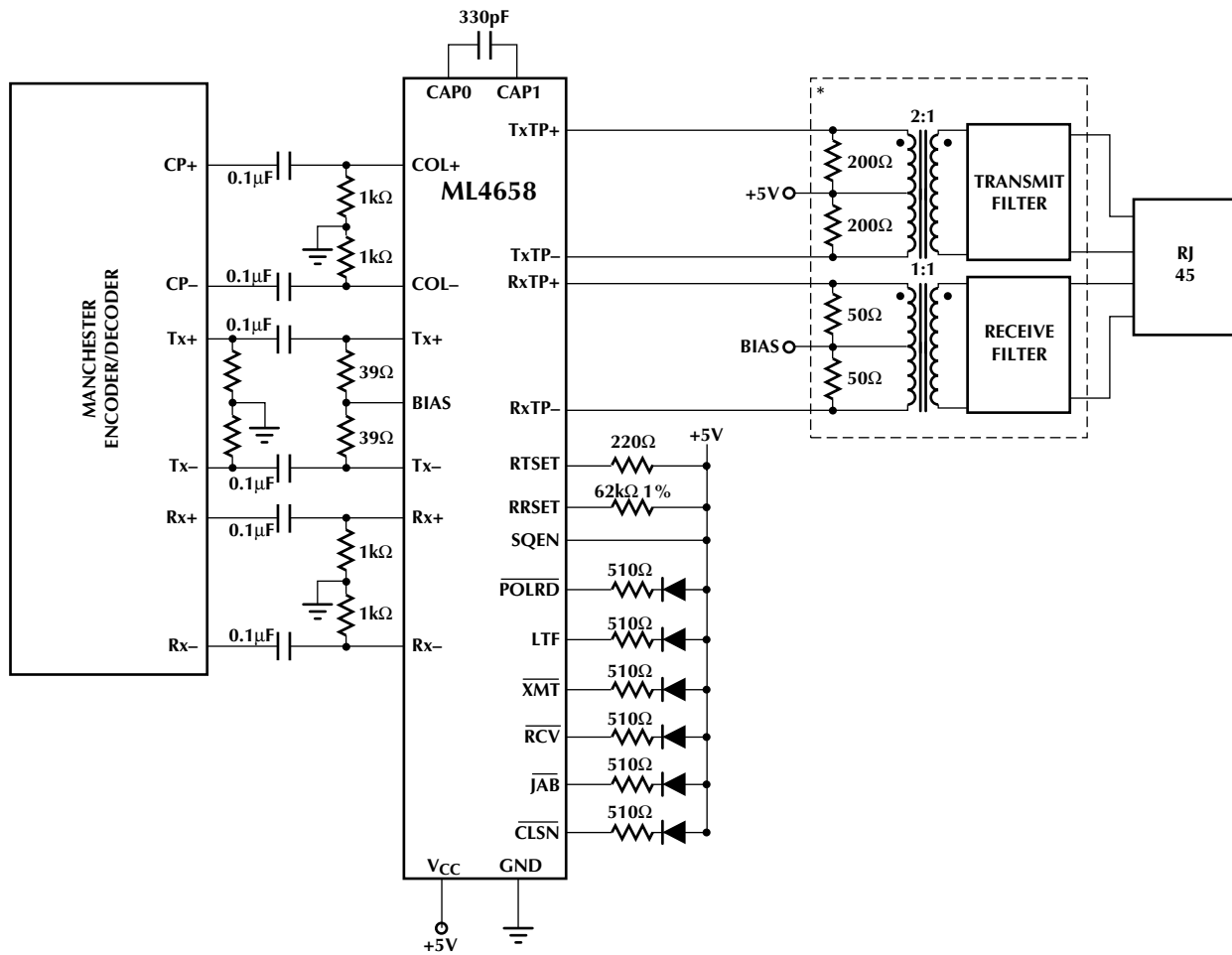
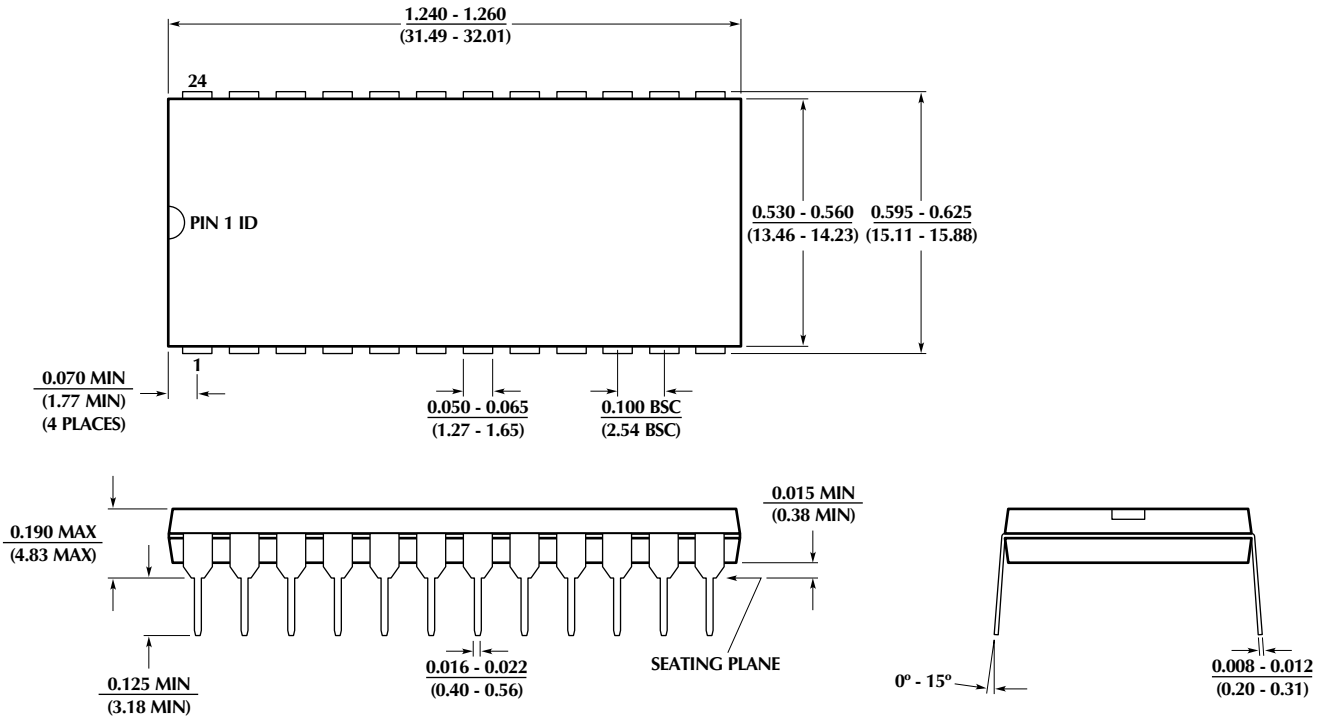

Figure 13. Internal MAU

## PHYSICAL DIMENSIONS inches (millimeters)

**Package: P24  
24-Pin PDIP**



**Package: Q28  
28-Pin PLCC**

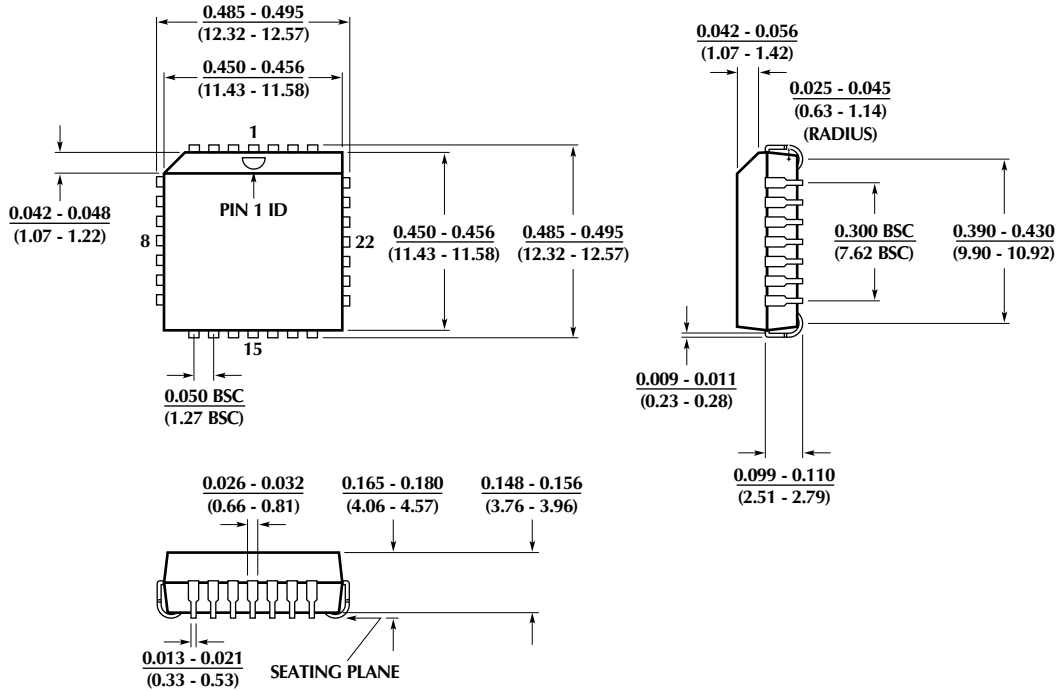



## ORDERING INFORMATION

ORDERING NUMBER	AUTO-POLARITY	PACKAGE
ML4658CP	Yes	24-Pin PDIP (P24N)
ML4658CQ	Yes	28-Pin PLCC (Q28)

© Micro Linear 1998.  **Micro Linear** is a registered trademark of Micro Linear Corporation. All other trademarks are the property of their respective owners.

Products described herein may be covered by one or more of the following U.S. patents: 4,897,611; 4,964,026; 5,027,116; 5,281,862; 5,283,483; 5,418,502; 5,508,570; 5,510,727; 5,523,940; 5,546,017; 5,559,470; 5,565,761; 5,592,128; 5,594,376; 5,652,479; 5,661,427; 5,663,874; 5,672,959; 5,689,167; 5,714,897; 5,717,798; 5,742,151; 5,747,977; 5,754,012; 5,757,174; 5,767,653; 5,777,514; 5,793,168; 5,798,635; 5,804,950; 5,808,455; 5,811,999; 5,818,207; 5,818,669; 5,825,165; 5,825,223. Japan: 2,598,946; 2,619,299; 2,704,176; 2,821,714. Other patents are pending.

Micro Linear reserves the right to make changes to any product herein to improve reliability, function or design. Micro Linear does not assume any liability arising out of the application or use of any product described herein, neither does it convey any license under its patent right nor the rights of others. The circuits contained in this data sheet are offered as possible applications only. Micro Linear makes no warranties or representations as to whether the illustrated circuits infringe any intellectual property rights of others, and will accept no responsibility or liability for use of any application herein. The customer is urged to consult with appropriate legal counsel before deciding on a particular application.

2092 Concourse Drive  
San Jose, CA 95131  
Tel: (408) 433-5200  
Fax: (408) 432-0295  
[www.microlinear.com](http://www.microlinear.com)