

Flyback Power Factor Controller

GENERAL DESCRIPTION

The ML4813 is a PWM controller designed for use in a discontinuous "flyback" or "buck-boost" type power factor correction (PFC) system for low power, low cost applications.

The circuit includes a precision reference, oscillator, error amplifier, over-voltage comparator, over-current comparator, and an extra op-amp as well as a high current output. In addition, start-up is simplified by an under-voltage lockout circuit.

In a typical application, the ML4813 functions as a voltage mode regulator. By maintaining a constant duty cycle, the current follows the input voltage, making the impedance of the entire circuit appear purely resistive. With the flyback circuit, power factors of 0.99 are easily achievable with a small output inductor and a minimum of external components.

FEATURES

- Precision buffered 5V reference
- Extra op-amp for output voltage instrumentation amplifier
- Overcurrent comparator for switch protection
- Soft start and under-voltage lockout for easy low surge off-line starting
- 1A peak current Totem-pole output drive
- Overvoltage comparator eliminates output "runaway" due to load removal
- Large oscillator amplitude for better noise immunity

*** This Part Is End Of Life As Of August 1, 2000**

BLOCK DIAGRAM

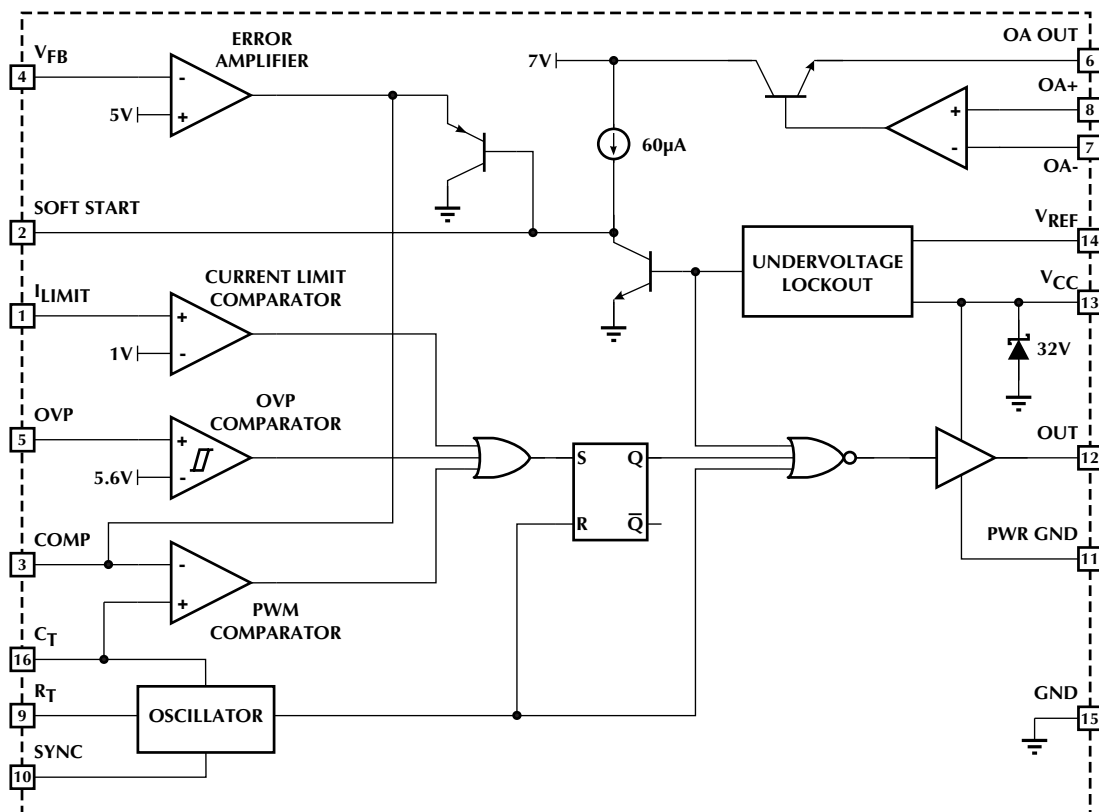

PIN CONFIGURATION

ML4813
16-Pin PDIP (P16)
16-Pin SOIC (S16W)

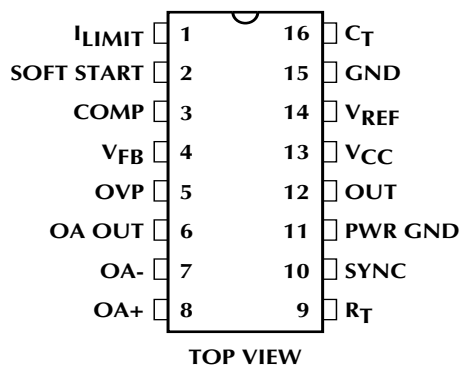

PIN DESCRIPTION

PIN	NAME	FUNCTION
1	I _{LIMIT}	Current limit sense pin which is normally connected to the sense resistor. When I _{LIMIT} exceeds 1V, the PWM cycle is terminated
2	SOFT START	Connection for the soft start capacitor
3	COMP	Output of error amplifier and input to the PWM comparator
4	V _{FB}	Control loop feedback voltage
5	OVP	Overvoltage comparator input
6	OA OUT	Output of the uncommitted op amp
7	OA-	Inverting input of the uncommitted op amp
8	OA+	Non-inverting input of the uncommitted op amp
9	R _T	Connection for the oscillator timing resistor
10	SYNC	Input for synchronizing the oscillator to an external source
11	PWR GND	Return for the high current output transistors
12	OUT	High current driver output
13	V _{CC}	Power supply input
14	V _{REF}	Buffered reference output
15	GND	Analog signal ground
16	C _T	Connection for the oscillator timing capacitor

ABSOLUTE MAXIMUM RATINGS

Absolute maximum ratings are those values beyond which the device could be permanently damaged. Absolute maximum ratings are stress ratings only and functional device operation is not implied.

Supply Current	40mA
OUT Current	±1A
OUT Energy (capacitive load, per cycle)	5μJ
COMP Sink Current	10mA
C _T Charging Current	5mA
Analog Input Voltage (pins 1, 3-8)	GND - 0.3V to 5.5V
Junction Temperature	150°C
Storage Temperature Range	-65°C to 150°C

Lead Temperature (Soldering, 10 sec)	260°C
Thermal Resistance (θ _{JA})	
PDIP	88°C/W
SOIC	105°C/W

OPERATING CONDITIONS

Temperature Range	
ML4813CX	0°C to 70°C
ML4813IX	-40°C to 85°C

ELECTRICAL CHARACTERISTICS

Unless otherwise specified, R_T = 14kΩ, C_T = 1nF, T_A = Operating Temperature Range (Notes 1, 2)

PARAMETER	CONDITIONS	MIN	TYP	MAX	UNITS
OSCILLATOR					
Initial Accuracy	T _j = 25°C	90	97	104	kHz
Voltage Stability	12V < V _{CC} < 18V		0.3		%
Temperature Stability				2	%
Total Variation	Line, temp	88		108	kHz
Ramp Valley				1.0	V
Ramp Peak			4.3		V
R _T Voltage		4.8	5.0	5.2	V
Discharge Current	T _j = 25°C, V(C _T) = 2V		7.5	8.4	9.3 mA
	V(C _T) = 2V		7.2	8.4	9.5 mA
SYNC Threshold		0.8	1.4	2.0	V
SYNC Bias Current				350	800 μA
REFERENCE					
Output Voltage (V _{REF})	T _j = 25°C, I _{REF} = 1mA		4.95	5.00	5.05 V
Line Regulation	12V < V _{CC} < 25V		6	20	mV
Load Regulation	1mA < I _{REF} < 20mA		3	20	mV
Temperature Stability				0.4	%
Total Variation	Line, load, temp	4.9		5.1	V
Output Noise	10Hz to 10kHz		50		μV
Long Term Stability	T _j = 125°C, 1000 hours			5	25 mV
Short Circuit Current	V _{REF} = GND		-30	-85	-180 mA

ELECTRICAL CHARACTERISTICS (cont.)

PARAMETER	CONDITIONS	MIN	TYP	MAX	UNITS	
ERROR AMPLIFIER						
Input Offset Voltage			-15	15	mV	
Input Bias Current			-0.1	-1.0	μ A	
Open Loop Gain	$1V < COMP < 5V$	60	75		dB	
PSRR	$12V < V_{CC} < 25V$	60	70		dB	
Output Sink Current	$COMP = 1.1V, V_{FB} = 6.2V$		2	12	mA	
Output Source Current	$COMP = 5V, V_{FB} = 4.8V$		-0.5	-1.0	mA	
Output High Voltage	$I_{COMP} = -0.5mA, V_{FB} = 4.8V$		5.3	6.4	V	
Output Low Voltage	$I_{COMP} = 2mA, V_{FB} = 6.2V$			0.5	1.0	V
Unity Gain Bandwidth				1.0	MHz	
UNCOMMITTED OP AMP						
Input Offset Voltage			-10	10	mV	
Input Bias Current			-0.1	-2.0	μ A	
Input Offset Current			-350	350	nA	
Open Loop Gain			90		dB	
PSRR			80	125	dB	
Output High Voltage	$I_{COMP} = -10mA$		6.5	8	V	
Output Low Voltage	$R_L = 10k\Omega$		200	500	mV	
I_{LIMIT} COMPARATOR						
Input Trip Point			0.8	1.0	1.2	V
Input Bias Current			-2	-15	μ A	
Propogation Delay Time			150		ns	
OVP COMPARATOR						
Input Trip Point			5.4	5.55	5.7	V
Hysteresis			100		mV	
Input Bias Current			-0.3	3	181A	
PWM COMPARATOR						
Input Common Mode Range			-0.2	5.5	V	
Input Bias Current			-2	-10	μ A	
Propogation Delay Time			150		ns	
SOFT START						
Soft Start Current	$V_{SOFT START} = 1V$		40	65	90	μ A

ELECTRICAL CHARACTERISTICS (cont.)

PARAMETER	CONDITIONS	MIN	TYP	MAX	UNITS	
OUTPUT						
Output Low Voltage	$I_{OUT} = 10\text{mA}$			0.1	0.4	V
	$I_{OUT} = 200\text{mA}$		1.2	2.2	V	
	$V_{CC} = 8\text{V}, I_{OUT} = 5\text{mA}$		0.1	0.8	V	
Output High Voltage	$I_{OUT} = -20\text{mA}$		13	13.6	V	
	$I_{OUT} = -200\text{mA}$	12	13.4		V	
Rise/Fall Time	$C_L = 1000\text{pF}$		50		ns	
UNDERVOLTAGE LOCKOUT						
Start-up Threshold		15	16.3	17.5	V	
Shutdown Threshold		9	10.1	11.2	V	
V_{REF} Good Threshold			4.4		V	
SUPPLY						
Start-up Current	$V_{CC} = 14\text{V}$		0.9	1.5	mA	
Operating Current			20	30	mA	
Shunt Regulator Voltage	$I_{CC} = 30\text{mA}$	25	30	34	V	

Note 1: Limits are guaranteed by 100% testing, sampling, or correlation with worst-case test conditions.

Note 2: V_{CC} is raised above the UVLO start-up threshold, then returned to 15V.

FUNCTIONAL DESCRIPTION

OSCILLATOR

The ML4813 oscillator charges the external capacitor (C_T) with a current (I_{SET}) equal to $5/R_{SET}$. When the capacitor voltage reaches the upper threshold, the comparator changes state and the capacitor discharges to the lower threshold through Q1. While the capacitor is discharging, Q2 provides a high pulse.

The oscillator period can be described by:

$$t_{OSC} = t_{RAMP} + t_{DEADTIME} \quad (1)$$

where:

$$t_{RAMP} = \frac{C_T}{I_{SET}} \quad (2)$$

and:

$$t_{DEADTIME} = \frac{C_T}{8.4mA - I_{SET}} \quad (3)$$

A graph showing the relationship between R_T , C_T , the oscillator frequency, and maximum duty cycle is given in Figure 1. A pulse of a duration shorter than $t_{DEADTIME}$ from an external frequency source set to a higher frequency than f_{OSC} can be applied to pin SYNC to synchronize the oscillator. R_{SYNC} and C_{SYNC} shorten longer pulses, as shown in Figure 2.

OUTPUT DRIVER STAGE

The ML4813 output driver is a 1A peak output high speed totem-pole circuit designed to quickly drive capacitive loads such as MOSFET gates. See Figure 3 for the output saturation characteristics for sourcing and sinking current.

ERROR AMPLIFIER

The ML4813 error amplifier is a high open loop gain, wide bandwidth amplifier. See Figure 4 for the gain and phase plot.

UN-COMMITTED OP-AMP

The ML4813 contains an uncommitted op amp which is normally configured as a differencing amplifier to sense the output voltage. The output voltage in the flyback configuration is not ground referenced. The op amp in the ML4813 is a PNP input amplifier similar to the LM324 but with an open emitter class A output stage.

REFERENCE

The reference output voltage versus output current characteristic is shown in Figure 5.

UNDERVOLTAGE LOCKOUT

On power-up, the ML4813 is in the UVLO condition;

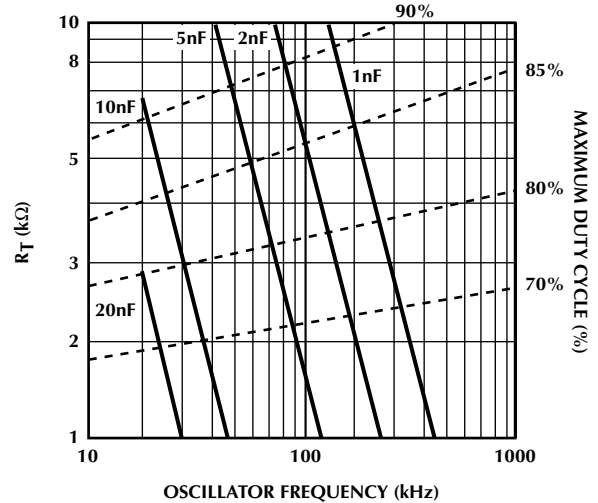

Figure 1. Oscillator Timing Resistance vs. Frequency

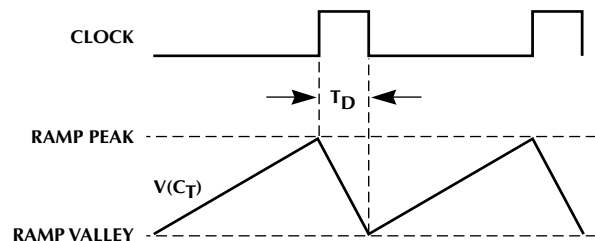
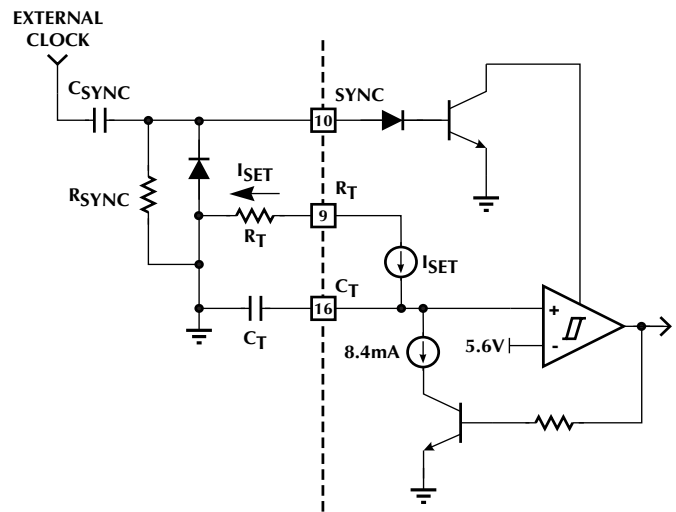

Figure 2. Oscillator Block Diagram

output low and quiescent current low. The ML4813 becomes operational when V_{CC} reaches 16V. When V_{CC} drops below 10V, the UVLO condition is re-imposed. During UVLO, the V_{REF} pin is off, making it usable as a "flag" for starting up a down-stream PWM converter.

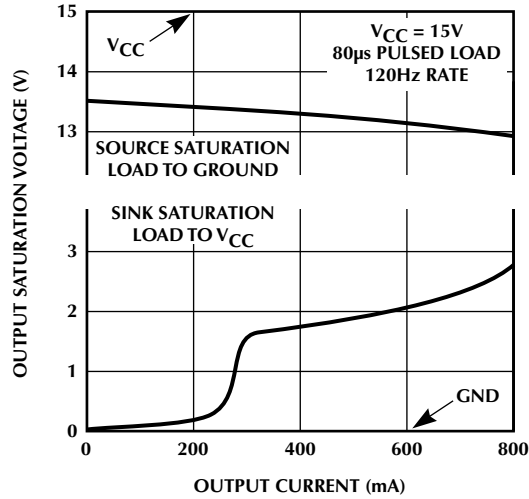

Figure 3. Output Saturation Voltage vs. Output Current

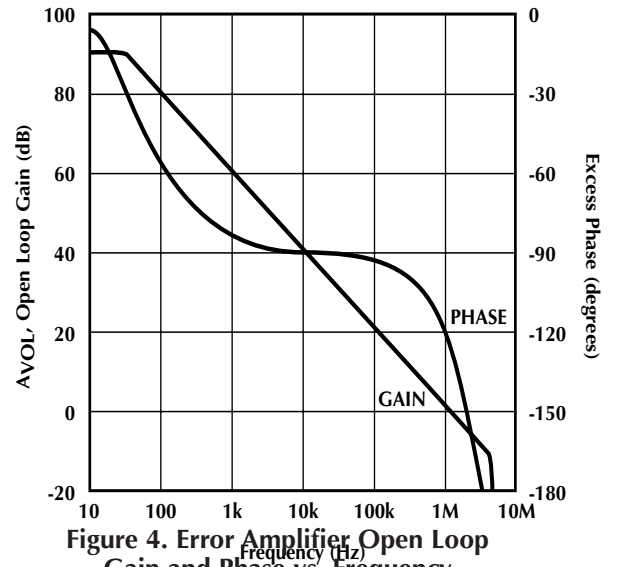

Figure 4. Error Amplifier Open Loop Gain and Phase vs. Frequency

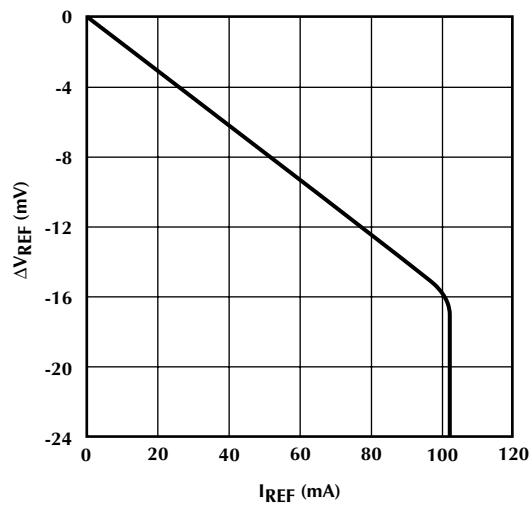

Figure 5. Reference Load Regulation vs. Output Current

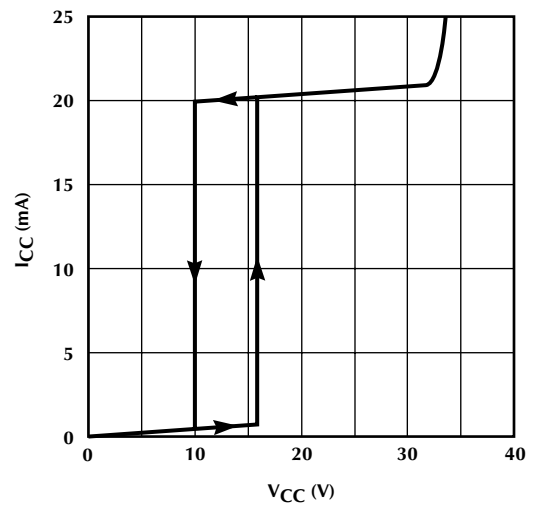

Figure 6. Supply Current vs. Supply Voltage

APPLICATIONS

The ML4813 is used to implement a discontinuous mode flyback (buck-boost) power factor regulator as shown in Figure 7. This topology is particularly well suited for low power applications such as fluorescent ballasts and low power switching supplies. It is also a useful topology when there is a requirement for the output voltage to be lower than the peak input voltage, or where an isolated output is required. This is not possible with a boost topology, where the output voltage must always be higher than the maximum peak of the input voltage range. The typical input range for the flyback power factor regulator is from 90VAC to 260VAC.

The regulator operates in the discontinuous current conduction mode. The inductor energy stored during the ON time of the power switch Q is completely delivered to the output capacitance during the OFF time. Under steady state conditions, the inductor current at the beginning of the ON time starts to ramp-up from 0 Amps to a value that is determined by the instantaneous value of the input full wave rectified voltage; the ON time as it is set by the error amplifier and the PWM comparator; and finally by the inductor itself.

The expression for the inductor peak current is given by:

$$I_L(\theta) = \frac{V_{IN}(\theta) \times t_{ON}}{L} \quad (4)$$

Where:

$I_L(\theta)$ = instantaneous peak inductor current

t_{ON} = Power MOSFET "ON" time

$V_{IN}(\theta) = V_P \sin \theta$ = Instantaneous input voltage

V_P = Input peak voltage

Figure 8 shows the relationship between the low frequency envelope and the high frequency inductor current. Note that for clarity the scale between the two

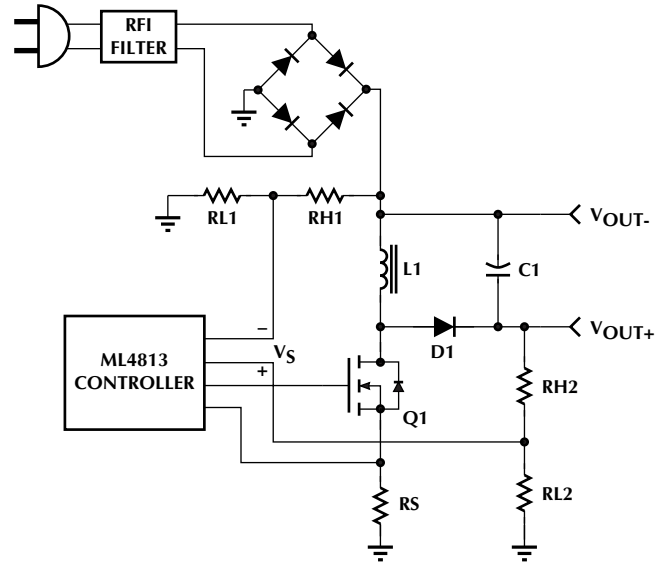

Figure 7. Simplified Application Circuit

waveforms has not been preserved. Normally for 60Hz input line and 100kHz switching frequency, each half of the sine wave contains approximately 833 high frequency triangular waveforms.

The envelope of the peaks of the switch current, which in this case represents the current drawn from the input source, has a sinewave shape. This relationship is shown as:

$$I_L(\theta) = I_p \times \sin\theta \quad (5)$$

By combining (4) and (5), the following useful relationship is obtained:

$$t_{ON} = \frac{L \times I_p}{\sqrt{2} \times V_{RMS}} \quad (6)$$

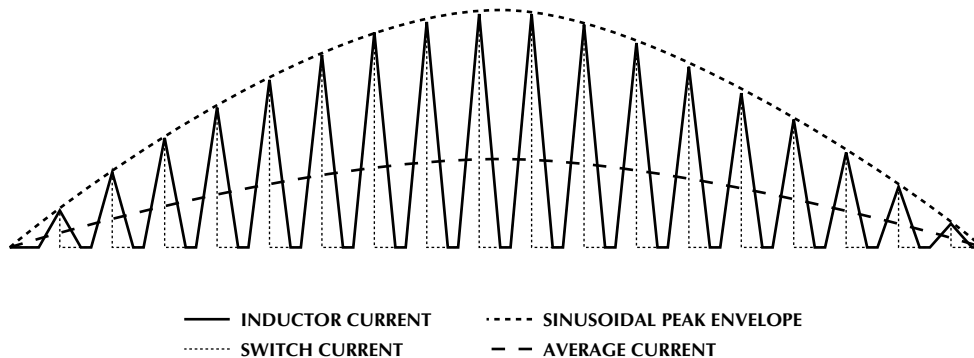

Figure 8. Switch and Line Currents in the Flyback PFC Circuit

APPLICATIONS (Continued)

Note that $V_{IN}(\theta) = V_P \times \sin(\theta)$ and that $V_P = 1.414 \times V_{RMS}$. The average value of the input triangular current is:

$$I_{AVG}(\theta) = \frac{t_{ON}}{2T} \times I_P \times \sin\theta \quad (7)$$

Where I_{AVG} is the average value of the switch current (the value of the current at the input of the regulator after filtering), and T is the period of the switch cycle.

Substitution of (6) into (7) yields:

$$I_{AVG}(\theta) = \frac{L \times I_P^2}{2.828 \times T \times V_{RMS}} \times \sin\theta \quad (8)$$

Equation (8) clearly shows that the average value of the switch current is sinusoidal and in phase with the input voltage. The peak value of the average current is:

$$I_{AVG(PEAK)} = \frac{L \times I_P^2}{2.828 \times T \times V_{RMS}} \times \sin\theta \quad (9)$$

Also:

$$I_{AVG(PEAK)} = \frac{\sqrt{2} \times P_{IN}}{V_{RMS}} \quad (10)$$

Rearranging equations (9) and (10) to solve for P_{IN} yields:

$$P_{IN} = \frac{L \times I_P^2 \times f}{4} \quad (11)$$

For optimum performance and the lowest inductor peak currents, the inductor current should be at the verge of continuity at the lowest operating voltage point and at full load. This can be satisfied if:

$$I_P \leq \frac{V_{IN} \times V_{OUT}}{f \times L \times (V_{IN} + V_{OUT})} \quad (12)$$

Finally, (11) and (12) can be combined to derive an upper bound for the inductor value that will guarantee that the regulator always stays in the discontinuous mode of operation. If the regulator were to operate in the continuous mode the average input current would not be sinusoidal.

$$L \leq \left[\frac{V_{IN} \times V_{OUT}}{2\sqrt{f \times P_{IN}} \times (V_{IN} + V_{OUT})} \right]^2 \quad (13)$$

FLYBACK INDUCTOR CALCULATION

Equation (13) gives the upper bound for the inductor value for any set of specified operating conditions. Normally, a few iterations may be required for finalizing the value to correct for second or third order effects. This means that a good initial value for the inductor is probably 10 to 20% lower than the value calculated by the right hand side expression in (13).

Several core materials are candidates for the inductor, such as powder iron, gapped ferrites, moly permalloy, etc. There are no particular restrictions on the inductor except that the inductance is the correct value and the losses are acceptable.

INPUT BYPASS CAPACITANCE

The triangular high frequency current is bypassed by an input capacitor (C_{IN}). This should be a high quality film capacitor with low ESR value for minimum losses and heating. Polyester, polypropylene or x-type (for line side) are good candidates. Typical values, depending on the power level, can range anywhere from 330nF to 1.5 μ F. The next filtering stage of the RFI filter has an inductor as an input to isolate C_{IN} from the other capacitors which may be present at the input circuit. Note that C_{IN} can be on either side of the bridge rectifier. The preferred location for low crossover distortion is on the input side. The ripple voltage across this capacitor is:

$$V_{C(P-P)} = \left(\frac{D}{C_{IN} \times f} \times \sqrt{\frac{P_{IN}}{L \times f}} \right) - \frac{\sqrt{2}P_{IN}}{C_{IN} \times f \times V_{IN}} \quad (14)$$

Where $V_{C(P-P)}$ is the peak to peak worst case high frequency capacitor voltage, and D is the switch duty cycle. The RFI filter that follows C_{IN} has to be able to attenuate $V_{C(P-P)}$ to the levels set by the relevant regulatory specifications.

INPUT TRANSIENT OVERVOLTAGE PROTECTION

Careful examination of the power circuits reveals that there is no large capacitance at the input of the regulator. The only capacitance present is that of the RFI filter capacitors. These capacitors have a combined value in the range of a few microfarads, and their ability to absorb and minimize any line induced transients is almost nonexistent. Transients can also occur under sudden load removal. If the line impedance is inductive, hazardous drain-source voltages may be generated leading to the destruction of the power MOSFET. To keep this from happening, a transient over-voltage protection device should be installed such that enough safety margin is allowed for the power MOSFET. A good rule of thumb is:

$$BV_{DSS} > V_{CLAMP} + V_{OUT(OVP)} \quad (15)$$

Where BV_{DSS} is the drain-source breakdown voltage for the MOSFET, V_{CLAMP} is the activation or clamping voltage of the over-voltage transient protector, and $V_{OUT(OVP)}$ is the maximum output voltage which is set by the OVP function of the controller.

THE OUTPUT CIRCUIT

The output circuit for this topology, although non-isolated, does not share the same ground with the power circuit. Therefore connecting the two grounds with the measuring leads of instruments should be avoided.

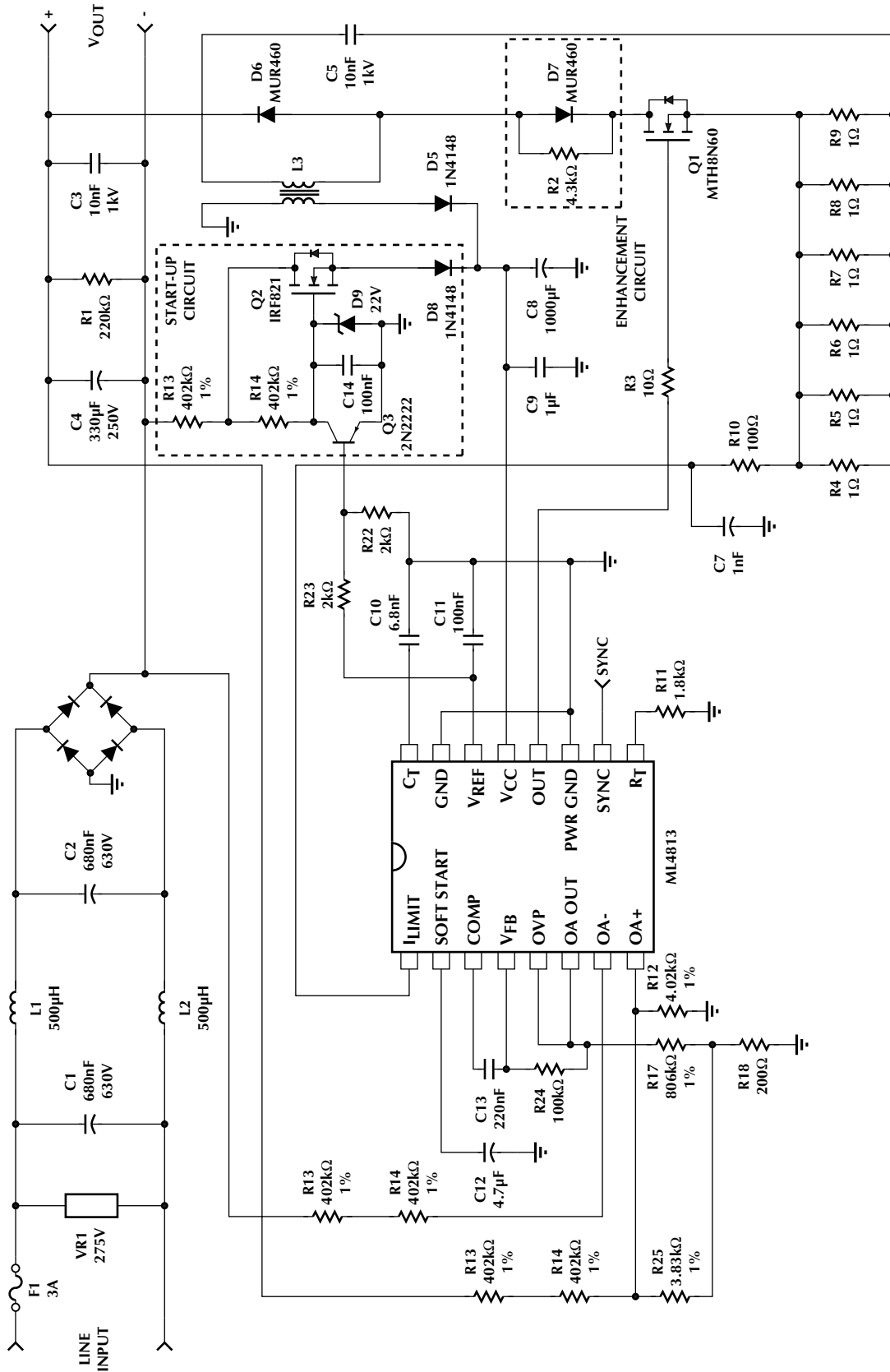

Figure 9. 80W Flyback Power Factor Regulator Using the ML4813

APPLICATIONS (Continued)

The output voltage "rides" on the input voltage when the (+) output is measured with respect to PWR GND as shown in Figure 10.

The extra op amp provided in the ML4813 can be used to sense the output voltage for regulation and overvoltage conditions. This op amp is connected as a difference amplifier with its output referenced to PWR GND. Resistors RH1, RH2, RL1, RL2 are used to scale down the voltage.

Normally, RH1 = RH2 = RH and RL1 = RL2 = RL. The voltage designated as V_S in Figure 7 is given by:

$$V_S = V_{OUT} \times \frac{RL}{RH + RL} \quad (16)$$

The output capacitance should be calculated such that it has the required output ripple at the worst case operating point. In addition, the ESR should be sufficiently low to prevent excessive dissipation due to RMS currents. The first criterion can be met by choosing the value of the output capacitor based on the following:

$$C_{OUT} \geq \frac{P_{IN}}{2\pi f_L \times \Delta V_R \times V_{OUT}} \quad (17)$$

Where:

C_{OUT} = Total output capacitance

P_{IN} = Total input power

ΔV_R = Peak output capacitor ripple voltage

f_L = Line frequency times 2 (120 for 60Hz line)

The second criterion for the selection of the output capacitor can be satisfied by choosing a component with adequately low ESR value that can safely bypass the RMS currents.

OUTPUT DIODE

The output diode can be a "fast" or ultrafast type depending on the operating frequency. Reverse recovery losses are low since under normal operating conditions, the regulator operates in discontinuous current mode. The diode should be rated to handle the maximum output current. The resulting power dissipation will be the forward drop of the diode times the output current.

POWER SWITCH

If a power MOSFET is used, it should be sized for the required efficiency. Lower $R_{DS(ON)}$ devices will yield lower losses, but if they are operated at high frequencies (100kHz), higher charge dumping losses will be experienced. The RMS current value through the power FET and the sensing resistor is:

$$I_{RMS} = \sqrt{\frac{L \times I_p^3 \times f_L}{4.24 \times V_{RMS}}} \times \sqrt{\sum_{k=1}^r \sin^2 \frac{k\pi}{r}} \quad (15)$$

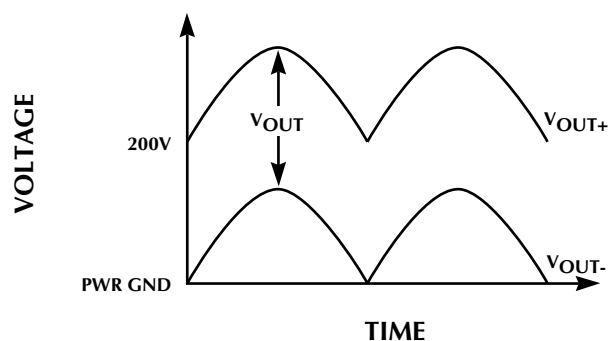

Figure 10. Output Voltage with Respect to PWR GND

Where:

I_{RMS} = Total RMS current through the power MOSFET

f_L = Line frequency times 2 (120 for 60Hz line)

r = f_{SWITCH}/f_L

Table 1 is provided to assist in calculating (18). When the power switch is a bipolar transistor (constant V_{CE} drop), then the power dissipation produced can be calculated by:

$$P_D = \frac{0.9 \times P_{IN}}{V_{RMS}} \times V_{CE} \quad (19)$$

Where:

P_D = Power dissipation in the transistor

V_{RMS} = RMS value of the minimum input voltage

V_{CE} = Forward drop of the power transistor

f_{SWITCH} (kHz)	r	$\sqrt{\sum_{k=1}^r \sin^2 \frac{k\pi}{r}}$
20	167	9.1
30	250	11.2
40	333	12.9
50	417	14.4
60	500	25.8
70	583	17.1
80	667	18.3
90	750	19.4
100	833	20.4
110	917	21.4
120	1000	22.4
130	1083	23.3
140	1167	24.2
150	1250	25.0
160	1333	25.7
170	1417	26.5
180	1500	27.3
190	1583	28.0
200	1667	28.9

Table 1. Constants for Calculating IRMS (Equation 18)

APPLICATIONS (Continued)

OFF-LINE START-UP AND BIAS SUPPLY GENERATION

A fast starting circuit is included in Figure 9. MOSFET Q2 quickly charges the ML4813 V_{CC} capacitor (C8) when the supply is initially turned on. This allows the supply to come on less than 1 second after AC power is applied. A simpler start-up circuit may be used which replaces the active circuit with a 39k Ω , 2W resistor but starts more slowly (up to 15 seconds under low line conditions). Systems which do not require quick starting can reduce cost with the latter start-up method.

POWER FACTOR ENHANCEMENT

Some combinations of line and load may exhibit distortion of the input current waveform. This distortion is usually caused by the inductor "ringing" with the C_{DS} of the power MOSFET, resulting in a non-zero inductor current at the beginning of the next cycle. This ringing can be dampened by using R2 and D7 as shown in Figure 9. Applications which can get by with slightly worse power factor can eliminate these components.

ADJUSTING THE OUTPUT VOLTAGE

The error amplifier creates an error voltage from the difference between the output voltage presented at OA OUT and the 5V internal reference. Since the output voltage is not ground referenced, the ML4813's internal op amp is connected as an instrumentation amplifier as shown in Figure 11.

The output voltage is set by resistors which determine the relationship between $(V_{OUT+} - V_{OUT-})$ and the output of the op amp. For the following discussion, $R15' = R15 + R16$ and $R14' = R13 + R14$. The differencing amplifier depends on the following relationships:

$$R14' = R15'$$

$$R12 = R25 + (R17 \parallel R18)$$

Then:

$$V_{OUT} = \left(\frac{5V + R18}{R17 + R18} \right) \times \left(\frac{R15'}{R15' + R25} \right) \times \left(\frac{R14'}{R12} + 1 \right) \quad (20)$$

Since R25 is a low value compared to R15', the second term reduces to approximately 1. The third term is set at approximately 200. Equation (20) can be reduced to:

$$V_{OUT} \cong 1000 \times \left(\frac{R18}{R17 + R18} \right) \quad (21)$$

The overvoltage comparator has a threshold that is set for $1.12 \times V_{OUT}$ when OVP and OA OUT are connected directly. Figure 12 shows the connection for setting an OVP trip point higher than $1.12 \times V_{OUT}$, where:

$$V_{OVP} \cong 1.12 \times V_{OUT} \times \left(\frac{R_A + R_B}{R_B} \right) \quad (22)$$

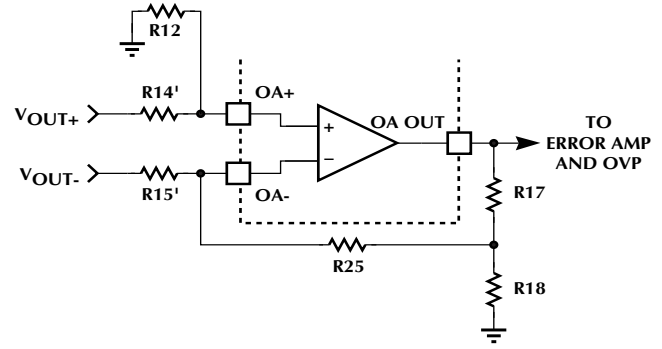

Figure 11. Ground Referencing the Op Amp Output

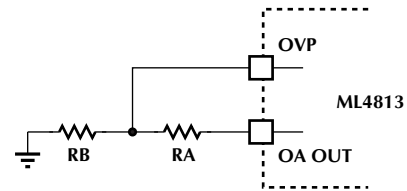

Figure 12. Setting OVP at $> 1.12 \times V_{OUT}$

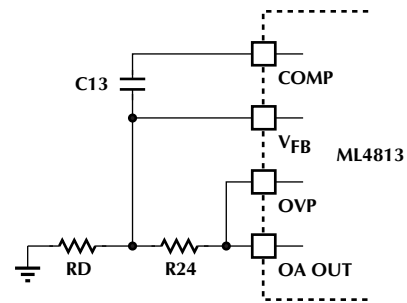

Figure 13. Setting OVP at $< 1.12 \times V_{OUT}$

Figure 15 shows OVP set for a voltage lower than $1.12 \times V_{OUT}$ where:

$$V_{OVP} \cong 1.12 \times V_{OUT} \times \left(\frac{RD + R24}{RD} \right) \quad (23)$$

APPLICATIONS (Continued)

INDUCTOR INFORMATION

L3 is the flyback inductor and also provides the operating power for the control circuitry. A gapped ferrite pot core was chosen for this application for its modest high frequency losses with high ripple current operation. Some possible choices are:

Manufacturer	Part #	Total Gap	N_p
Magnetics Inc.	F43019	0.05"	32
Phillips	3019 PL00-3F3	0.05"	32
Phillips	3019 PA125-3C8	0.07"	38

The first 2 cores are sold ungapped and require the use of a .025" spacer to gap the center leg to yield a total gap length of 0.05". If an ungapped core is used, a "shorted turn" should be employed as shown in Figure 14 to prevent radiated EMI. The third core listed is sold with its center leg pre-gapped (0.07" total) so that the outside of the core closes completely, providing shielding without a shorted turn. N_s should be 3 turns. All windings are #24AWG wire.

Inductors L1 and L2 are constructed using a powdered iron. This is a suitable material for these inductors since the high frequency ripple currents (and resulting flux excursions) are much less severe than for L3. The core selected is a MicroMetals T68-26D with 80 turns or #24AWG wire.

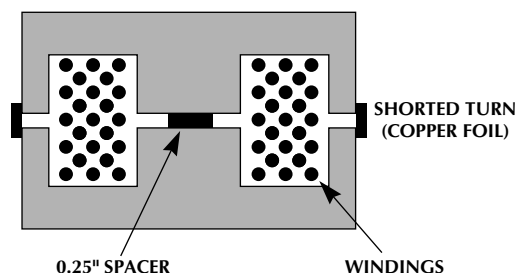
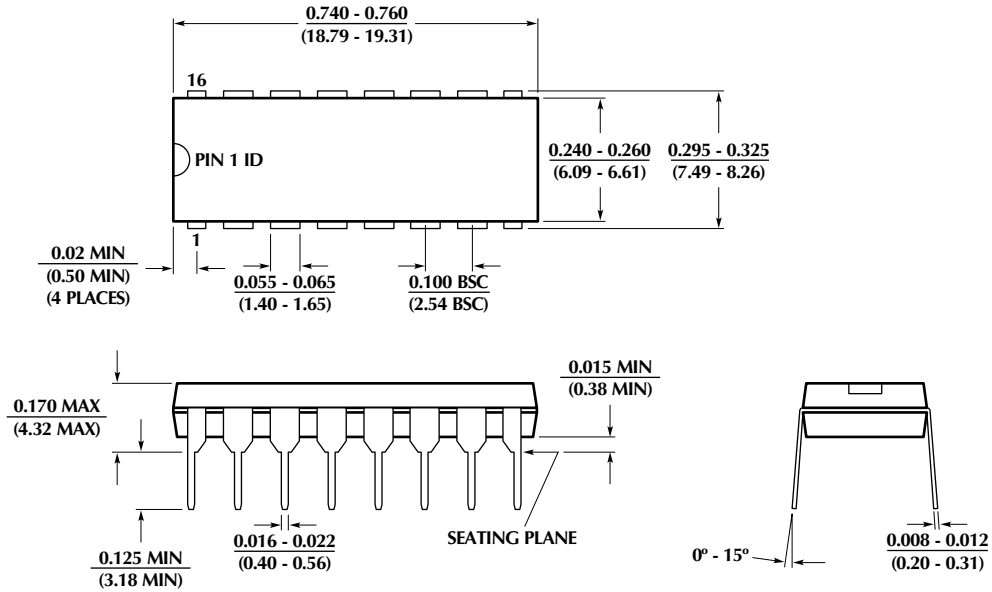

Figure 14. EMI Shielding for Ungapped Cores

PHYSICAL DIMENSIONS inches (millimeters)

**Package: P16
16-Pin PDIP**



**Package: S16W
16-Pin Wide SOIC**

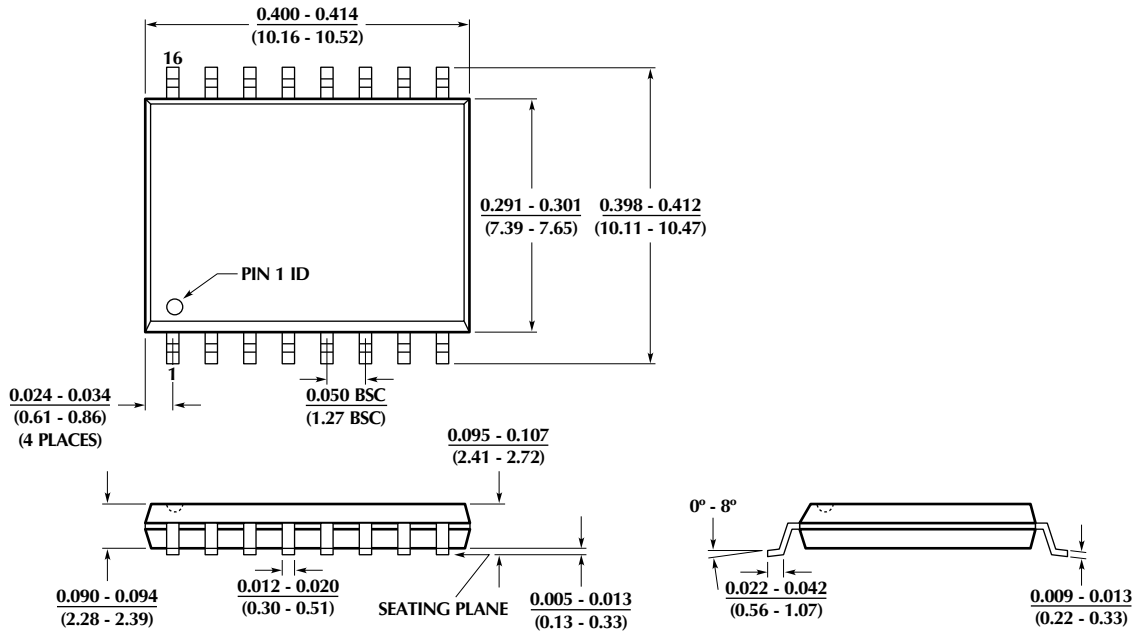

ORDERING INFORMATION

PART NUMBER	TEMPERATURE RANGE	PACKAGE
ML4813CP (EOL) ML4813CS (Obsolete)	0°C to 70°C 0°C to 70°C	16-Pin PDIP (P16) 16-Pin SOIC (S16W)
ML4813IP (Obsolete) ML4813IS (Obsolete)	-40°C to 85°C -40°C to 85°C	16-Pin PDIP (P16) 16-Pin SOIC (S16W)

© Micro Linear 1996  **Micro Linear** is a registered trademark of Micro Linear Corporation.

Products described herein may be covered by one or more of the following U.S. patents: 4,897,611; 4,964,026; 5,027,116; 5,281,862; 5,283,483; 5,418,502; 5,508,570; 5,510,727; 5,523,940; 5,546,017; 5,559,470; 5,565,761; 5,592,128; 5,594,376. Japan: 2,598,946; 2,619,299. Other patents are pending.

Micro Linear reserves the right to make changes to any product herein to improve reliability, function or design. Micro Linear does not assume any liability arising out of the application or use of any product described herein, neither does it convey any license under its patent right nor the rights of others. The circuits contained in this data sheet are offered as possible applications only. Micro Linear makes no warranties or representations as to whether the illustrated circuits infringe any intellectual property rights of others, and will accept no responsibility or liability for use of any application herein. The customer is urged to consult with appropriate legal counsel before deciding on a particular application.

2092 Concourse Drive
San Jose, CA 95131
Tel: 408/433-5200
Fax: 408/432-0295