



TC5066BP, TC5067BP

C²MOS DIGITAL INTEGRATED CIRCUIT
SILICON MONOLITHIC

TC5066BP 7-HIGH VOLTAGE BUFFER/NON INVERTING TYPE
TC5067BP 7-HIGH VOLTAGE BUFFER/INVERTING TYPE

TC5066BP and TC5067BP contain seven independent circuits of buffers. TC5066BP in non-inverting type and TC5067BP is inverting type.

As both have the output of open drain structure with high breakdown voltage P-channel MOS FET (-50 volts..Maximum Rating), these are suitable for driving fluorescent display tubes and for interfacing with high voltage MOS LSI's.

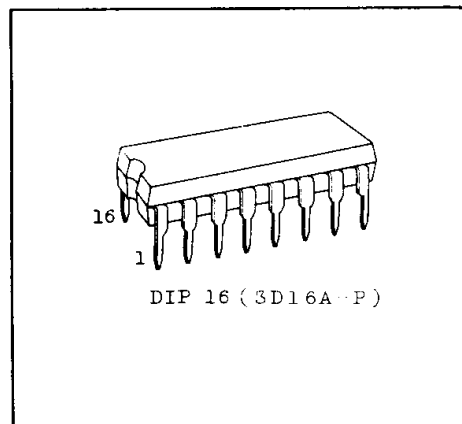

ABSOLUTE MAXIMUM RATINGS

CHARACTERISTIC	SYMBOL	RATING	UNIT
DC Supply Voltage	V _{DD}	V _{SS} -0.5 ~ V _{SS} +20	V
Input Voltage	V _{IN}	V _{SS} -0.5 ~ V _{DD} +0.5	V
Output Voltage	V _{OUT}	V _{DD} -50 ~ V _{DD} +0.5	V
Power Dissipation	P _D	300	mW
DC Input Current	I _{IN}	±10	mA
Storage Temperature Range	T _{stg}	-65 ~ 150	°C
Lead Temp./Time	T _{sol}	260°C · 10sec	

PIN ASSIGNMENT

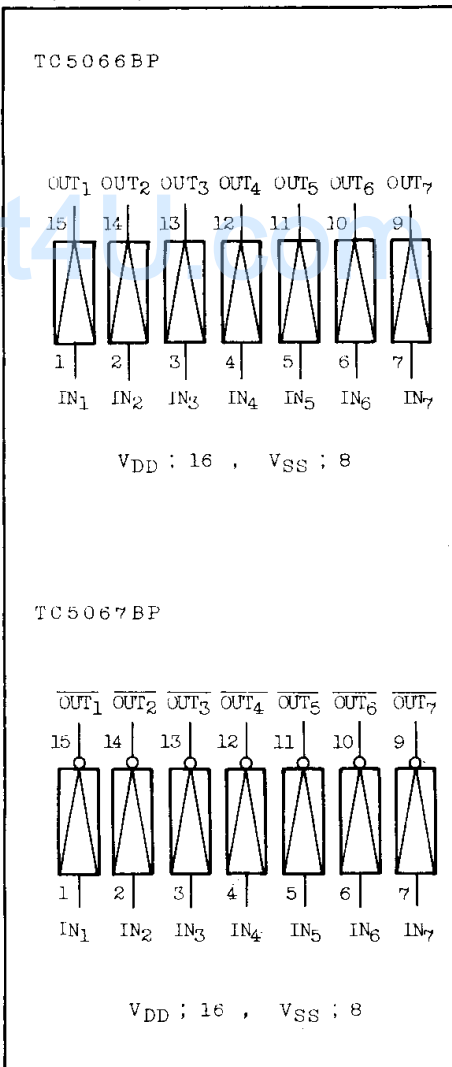

LOGIC DIAGRAM

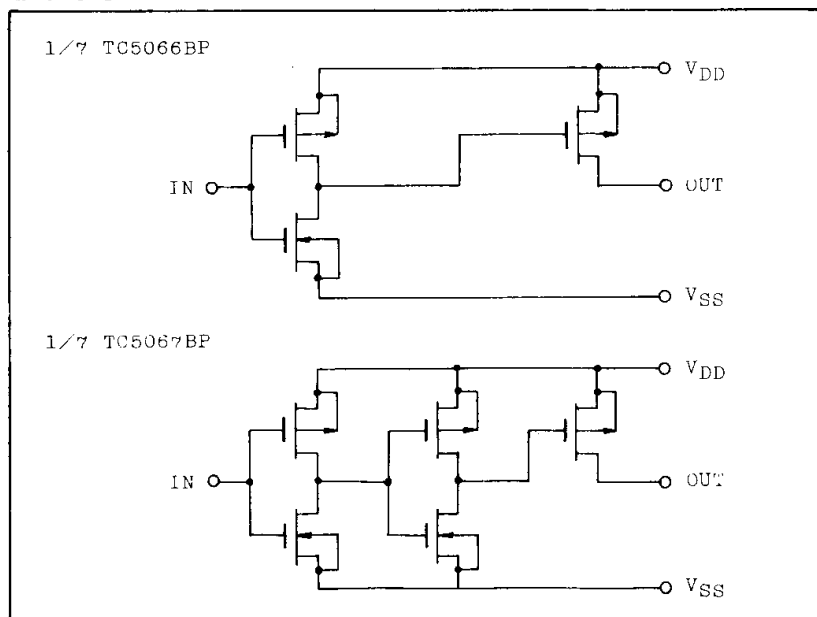

RECOMMENDED OPERATING CONDITIONS (V_{SS}=0V)

CHARACTERISTIC	SYMBOL		MIN.	TYP.	MAX.	UNIT
Supply Voltage	V _{DD}		3		18	V
Input Voltage	V _{IN}		0		V _{DD}	V
Operating Temp.	Topr		-40		85	°C

ELECTRICAL CHARACTERISTICS (V_{SS}=0V)

CHARACTERISTIC	SYMBOL	TEST CONDITIONS	V _{DD} (V)	-40°C		25°C			85°C		UNIT	
				MIN.	MAX.	MIN.	TYP.	MAX.	MIN.	MAX.		
High Level Output Voltage	V _{OH}	I _{OUT} < 1μA V _{IN} =V _{SS} or V _{DD}	5	4.95	-	4.95	5.00	-	4.95	-	V	
			10	9.95	-	9.95	10.00	-	9.95	-		
			15	14.95	-	14.95	15.00	-	14.95	-		
High Level Output Current	I _{OH}	V _{OH} =3V (V _{DD} -2V) V _{OH} =2V (V _{DD} -3V) V _{OH} =7V (V _{DD} -3V) V _{OH} =12V (V _{DD} -3V) V _{IN} =V _{SS} or V _{DD}	5	-6	-	-5	-10	-	-4	-	mA	
			5	-9	-	-8	-13	-	-6	-		
			10	-12	-	-10	-25	-	-8	-		
			15	-17	-	-15	-35	-	-12	-		
High Level Input Voltage (TC5066BP)	V _{IH}	V _{OUT} =4.5V V _{OUT} =9.0V V _{OUT} =13.5V *	5	4.0	-	4.0		-	4.0	-	V	
			10	8.0	-	8.0		-	8.0	-		
			15	12.5	-	12.5		-	12.5	-		
Low Level Input Voltage (TC5066BP)	V _{IL}	V _{OUT} =0.5V V _{OUT} =1.0V V _{OUT} =1.5V *	5	-	1.0	-		1.0	-	1.0	V	
			10	-	2.0	-		2.0	-	2.0		
			15	-	2.5	-		2.5	-	2.5		
High Level Input Voltage (TC5067BP)	V _{IH}	V _{OUT} =0.5V V _{OUT} =1.0V V _{OUT} =1.5V *	5	3.5	-	3.5	2.75	-	3.5	-	V	
			10	7.0	-	7.0	5.5	-	7.0	-		
			15	11.0	-	11.0	8.25	-	11.0	-		
Low Level Input Voltage (TC5067BP)	V _{IL}	V _{OUT} =4.5V V _{OUT} =9.0V V _{OUT} =13.5V *	5	-	1.5	-	2.25	1.5	-	1.5	V	
			10	-	3.0	-	4.5	3.0	-	3.0		
			15	-	4.0	-	6.75	4.0	-	4.0		
Output OFF Leak Current	I _{OFF}	V _{OUT} = 0V V _{OUT} = -30V	15	-	3	-	0.01	3	-	10	μA	
			15	-	10	-	1	10	-	20		
Input Current	H Level	I _{IH}	V _{IH} = 18V	18	-	0.3	-	10 ⁵	0.3	-	1.0	μA
	L Level	I _{IL}	V _{IL} = 0V	18	-	-0.3	-	10 ⁻⁵	-0.3	-	-1.0	
Quiescent Supply Current	I _{DD}	V _{IN} = V _{DD} , V _{SS} Outputs Open	5	-	4.0	-	0.005	4.0	-	30	μA	
			10	-	8.0	-	0.010	8.0	-	60		
			15	-	16.0	-	0.015	16.0	-	120		

* R_L = 20 kΩ

TC5066BP, TC5067BP

SWITCHING CHARACTERISTICS (Ta=25°C, VSS=0V, CL=50pF)

CHARACTERISTIC	SYMBOL	TEST CONDITIONS	VDD(V)	MIN.	TYP.	MAX.	UNIT
Output Rise Time	t _{TLH}	R _L = 20 kΩ	5	-	100	200	ns
			10	-	50	100	
			15	-	40	80	
Output Fall Time	t _{THL}	R _L = 20 kΩ	5	-	5.0	8.0	μs
			10	-	5.0	8.0	
			15	-	5.0	8.0	
(LOW-HIGH) Propagation Delay Time	tpLH	R _L = 20 kΩ	5	-	200	500	ns
			10	-	100	250	
			15	-	80	200	
(HIGH-LOW) Propagation Delay Time	tpHL	R _L = 20 kΩ	5	-	2.0	4.0	μs
			10	-	2.0	4.0	
			15	-	2.0	4.0	
Input Capacity	C _{IN}			-	5	7.5	pF

SWITCHING TIME TEST CIRCUIT AND WAVEFORM

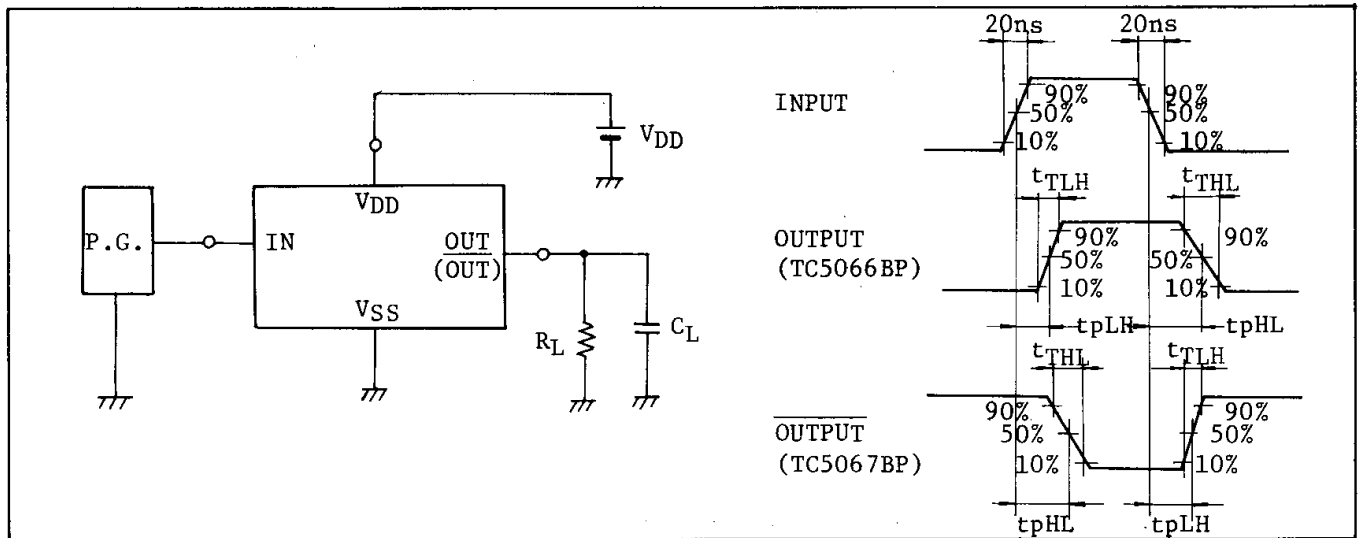

EXAMPLES OF APPLICABLE CIRCUITS

(1) Fluorescent Display Tube Driving Circuit

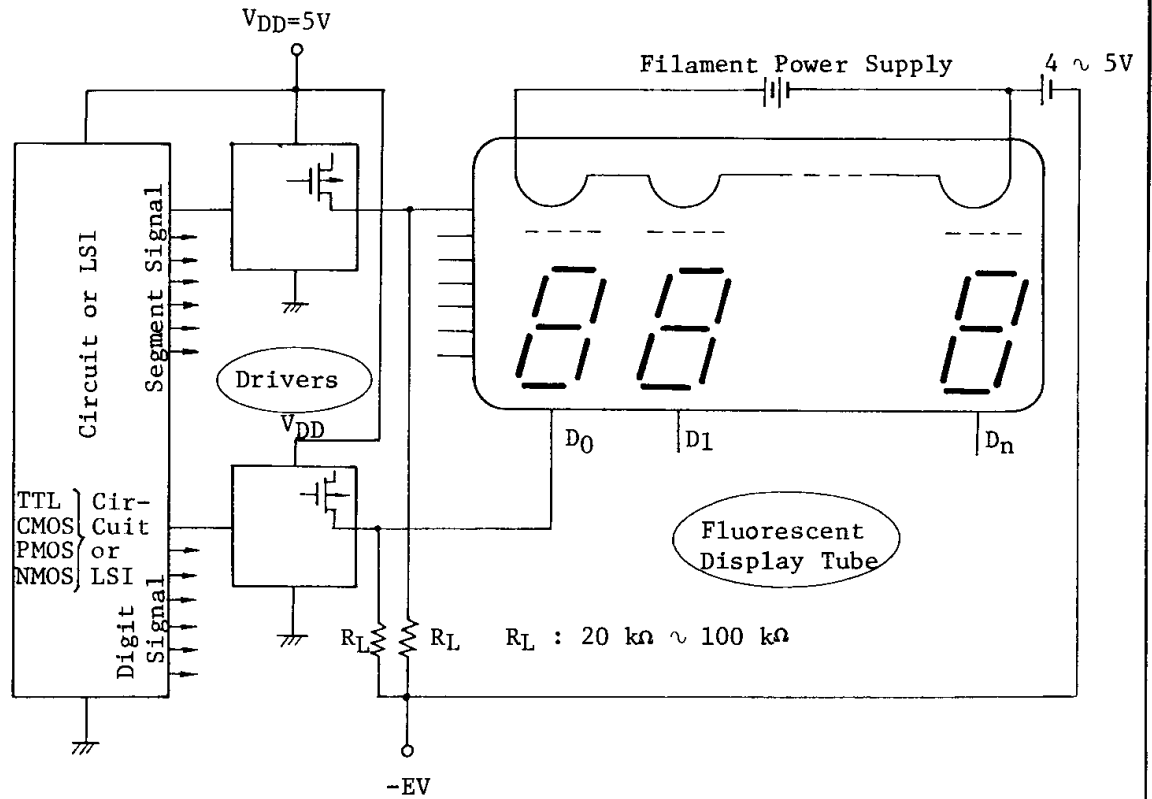

(2) Interface between CMOS and PMOS

