

# Low Power FM Transmitter System

MC2833 is a one-chip FM transmitter subsystem designed for cordless telephone and FM communication equipment. It includes a microphone amplifier, voltage controlled oscillator and two auxiliary transistors.

- Wide Range of Operating Supply Voltage (2.8–9.0 V)
- Low Drain Current ( $I_{CC} = 2.9 \text{ mA Typ}$ )
- Low Number of External Parts Required
- – 30 dBm Power Output to 60 MHz Using Direct RF Output
- + 10 dBm Power Output Attainable Using On-Chip Transistor Amplifiers
- Users Must Comply with Local Regulations on R.F. Transmission (FCC, DOT, P.T.T., etc)

## MC2833

### LOW POWER FM TRANSMITTER SYSTEM

#### SEMICONDUCTOR TECHNICAL DATA

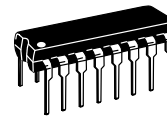

**P SUFFIX**  
PLASTIC PACKAGE  
CASE 648

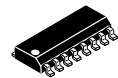

**D SUFFIX**  
PLASTIC PACKAGE  
CASE 751B  
(SO-16)

#### Representative Block Diagram

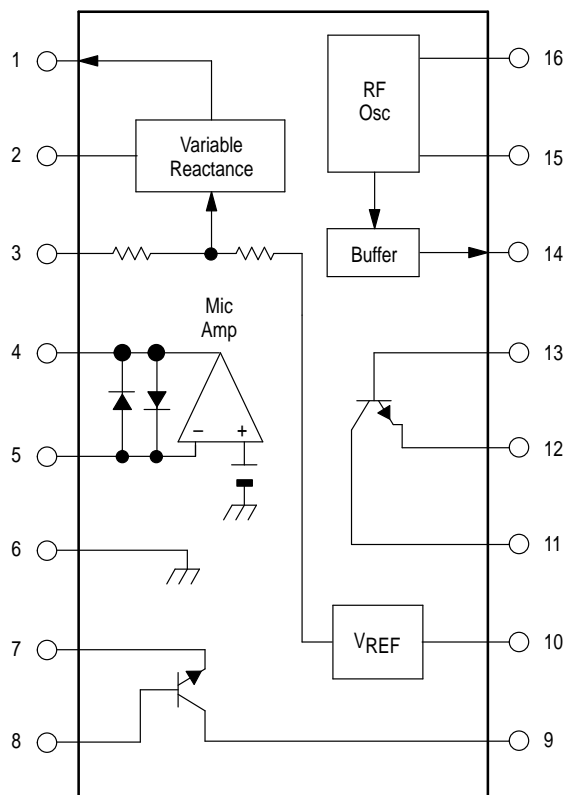

#### PIN CONNECTIONS

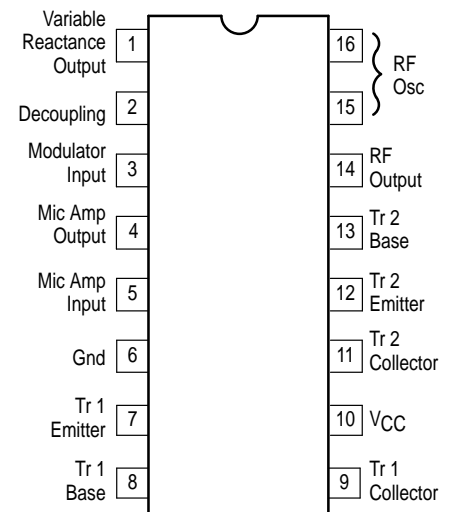

#### ORDERING INFORMATION

Device	Operating Temperature Range	Package
MC2833D	$T_A = -30 \text{ to } +75^\circ\text{C}$	SO-16
MC2833P		Plastic DIP

## MAXIMUM RATINGS

Ratings	Symbol	Value	Unit
Power Supply Voltage	$V_{CC}$	10 (max)	V
Operating Supply Voltage Range	$V_{CC}$	2.8–9.0	V
Junction Temperature	$T_J$	+ 150	°C
Operating Ambient Temperature	$T_A$	– 30 to + 75	°C
Storage Temperature Range	$T_{stg}$	– 65 to + 150	°C

ELECTRICAL CHARACTERISTICS ( $V_{CC} = 4.0$  V,  $T_A = 25^\circ\text{C}$ , unless otherwise noted)

Characteristics	Symbol	Pin	Min	Typ	Max	Unit
Drain Current (No input signal)	$I_{CC}$	10	1.7	2.9	4.3	mA

## FM MODULATOR

Output RF Voltage ( $f_o = 16.6$ MHz)	$V_{out\ RF}$	14	60	90	130	mVrms
Output DC Voltage (No input signal)	$V_{dc}$	14	2.2	2.5	2.8	V
Modulation Sensitivity ( $f_o = 16.6$ MHz) ( $V_{in} = 0.8$ V to 1.2 V)	SEN	3 14	7.0 –	10 –	15 –	Hz/mVdc
Maximum Deviation ( $f_o = 16.6$ MHz) ( $V_{in} = 0$ V to 2.0 V)	Fdev	3 14	3.0 –	5.0 –	10 –	kHz

## MIC AMPLIFIER

Closed Loop Voltage Gain ( $V_{in} = 3.0$ mVrms) ( $f_{in} = 1.0$ kHz)	$A_v$	4 5	27 –	30 –	33 –	dB
Output DC Voltage (No input signal)	$V_{out\ dc}$	4	1.1	1.4	1.7	V
Output Swing Voltage ( $V_{in} = 30$ mVrms) ( $f_{in} = 1.0$ kHz)	$V_{out\ P-P}$	4	0.8	1.2	1.6	Vp-p
Total Harmonic Distortion ( $V_{in} = 3.0$ mVrms) ( $f_{in} = 1.0$ kHz)	THD	4	–	0.15	2.0	%

## AUXILIARY TRANSISTOR STATIC CHARACTERISTICS

Characteristics	Symbol	Min	Typ	Max	Unit
Collector Base Breakdown Voltage ( $I_C = 5.0$ $\mu\text{A}$ )	$V_{(BR)CBO}$	15	45	–	V
Collector Emitter Breakdown Voltage ( $I_C = 200$ $\mu\text{A}$ )	$V_{(BR)CEO}$	10	15	–	V
Collector Substrate Breakdown Voltage ( $I_C = 50$ $\mu\text{A}$ )	$V_{(BR)CSO}$	–	70	–	V
Emitter Base Breakdown Voltage ( $I_E = 50$ $\mu\text{A}$ )	$V_{(BR)EBO}$	–	6.2	–	V
Collector Base Cut Off Current ( $V_{CB} = 10$ V) ( $I_E = 0$ )	$I_{CBO}$	–	–	200	nA
DC Current Gain ( $I_C = 3.0$ mA) ( $V_{CE} = 3.0$ V)	$h_{FE}$	40	150	–	–

## AUXILIARY TRANSISTOR DYNAMIC CHARACTERISTICS

Current Gain Bandwidth Product ( $V_{CE} = 3.0$ V) ( $I_C = 3.0$ mA)	$f_T$	–	500	–	MHz
Collector Base Capacitance ( $V_{CE} = 3.0$ V) ( $I_C = 0$ )	$C_{CB}$	–	2.0	–	pF
Collector Substrate Capacitance ( $V_{CS} = 3.0$ V) ( $I_C = 0$ )	$C_{CS}$	–	3.3	–	pF

# MC2833

Figure 1. Test Circuit

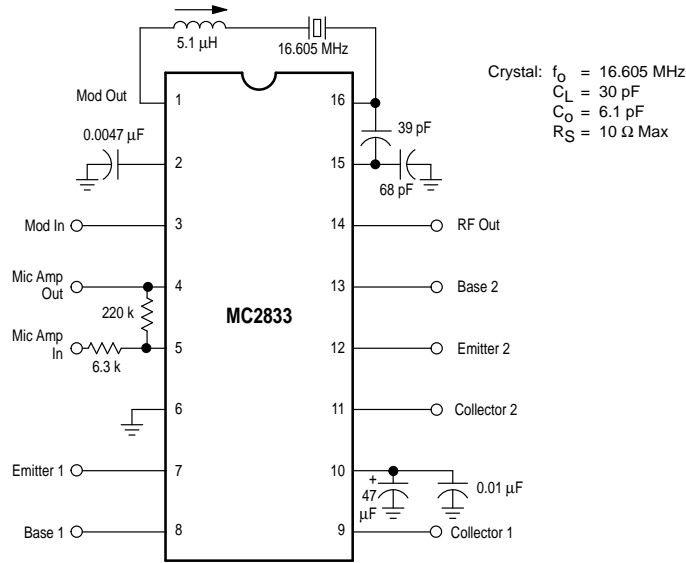
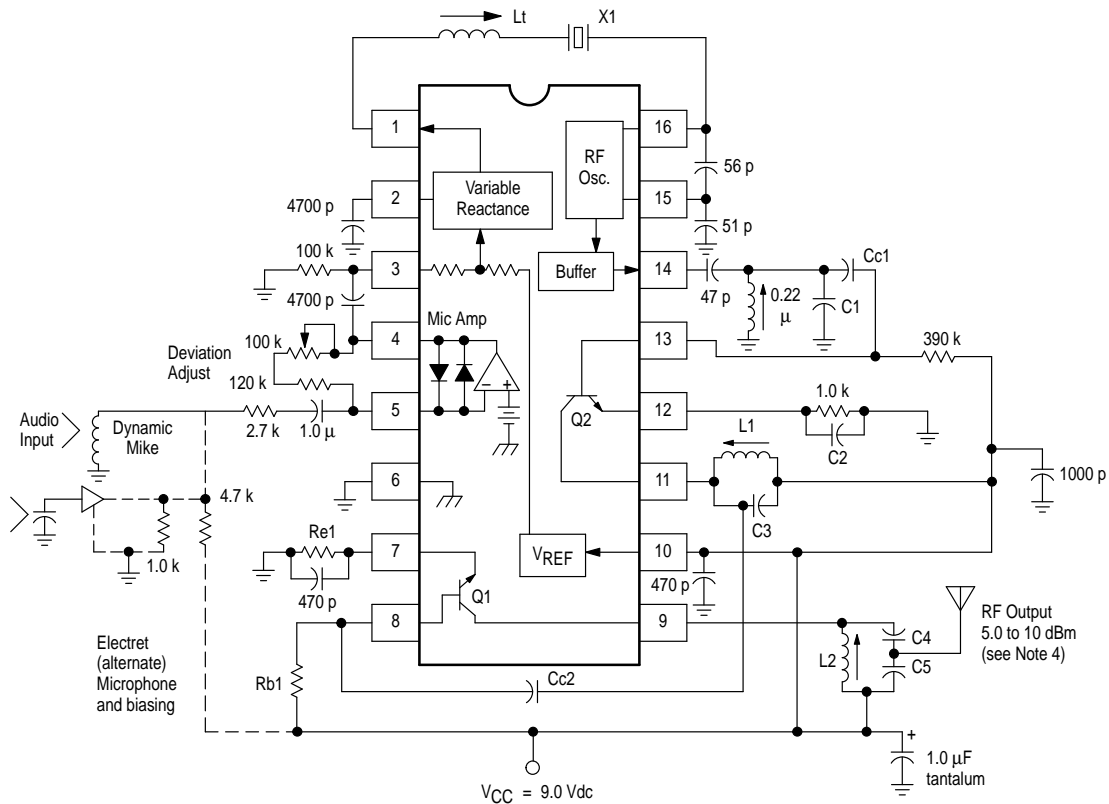

Figure 2. Single Chip VHF Narrowband FM Transmitter



**NOTES:**

1. Components versus output frequency:

Output RF	X1 (MHz)	Lt (μH)	L1 (μH)	L2 (μH)	Re1	Rb1	Cc1	Cc2	C1	C2	C3	C4	C5
50 MHz	16.6667	3.3–4.7	0.22	0.22	330	390 k	33 p	33 p	33 p	470 p	33 p	47 p	220 p
76 MHz	12.6000	5.1	0.22	0.22	150	300 k	68 p	10 p	68 p	470 p	12 p	20 p	120 p
144 MHz	12	5.6	0.15	0.10	150	220 k	47 p	10 p	68 p	1000 p	18 p	12 p	33 p

- Crystal X1 is fundamental mode, calibrated for parallel resonance with a 32 pF load. The final output frequency is generated by frequency multiplication within the MC2833 IC. The RF output buffer (Pin 14) and Q2 transistor are used as a frequency tripler and doubler, respectively, in the 76 and 144 MHz transmitters. The Q1 output transistor is a linear amplifier in the 49.7 MHz and 76 MHz transmitters, and a frequency doubler in the 144 MHz transmitter.
- All coils used are 7 mm shielded inductors, CoilCraft series M1175A, M1282A–M1289A, M1312A or equivalent.
- Power output is  $\approx +10$  dBm for 50 MHz and 76 MHz transmitters, and  $\approx +5.0$  dBm for the 144 MHz transmitter at  $V_{CC} = 8.0$  V. Power output drops with lower  $V_{CC}$ .
- All capacitors in microfarads, inductors in Henries and resistors in Ohms unless otherwise specified.
- Other frequency combinations may be set-up by simple scaling of the 3 examples shown.

Figure 3. Buffer/Multiplier (x3, Pin 14)  
(16 MHz Fundamental)

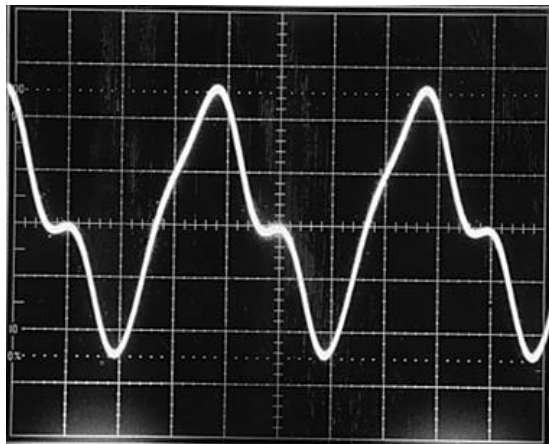

Figure 4. Input to Doubler (Pin 13)  
(50 MHz x 3 Component)

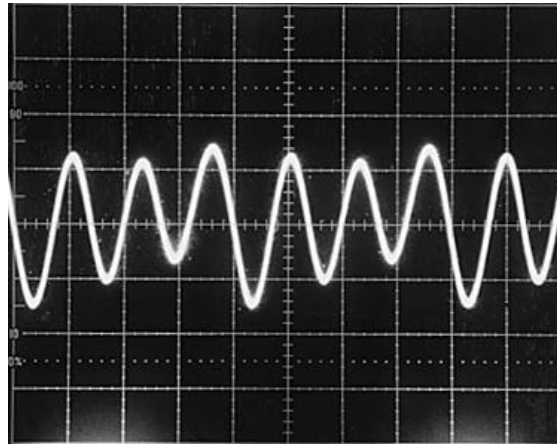

Figure 5. Doubler Output 76 MHz (Pin 11)

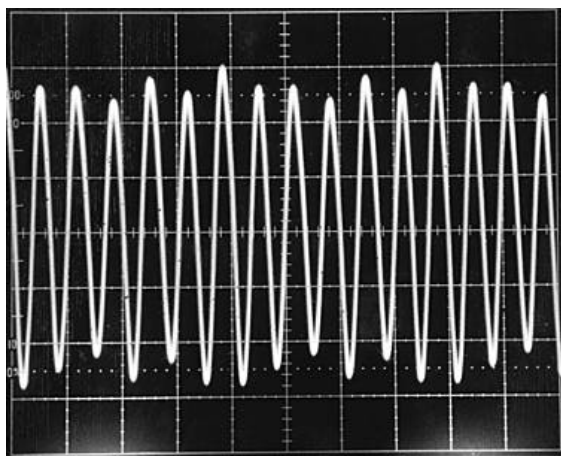

Figure 6. Spectrum

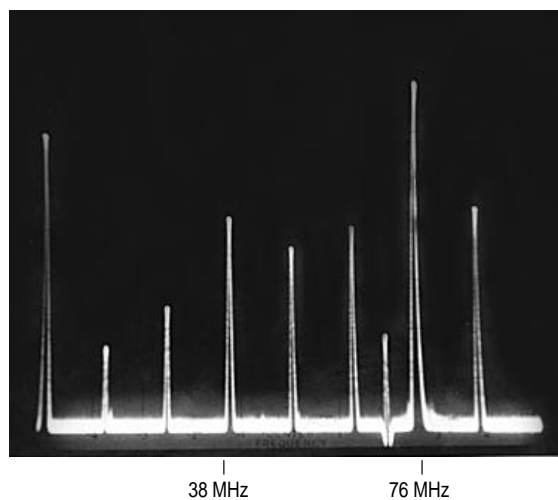

Figure 7. Output Spectrum (50 MHz)

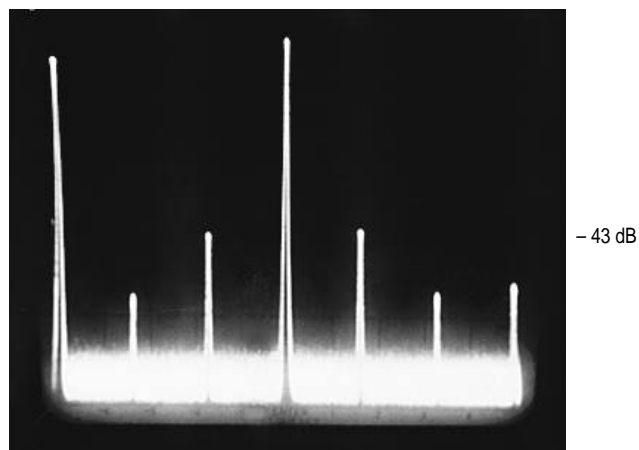
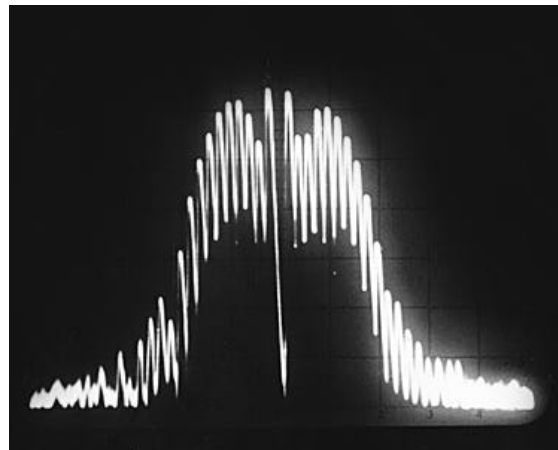

Figure 8. Modulation Spectrum  
(1.0 kHz Showing Carrier Null)



# MC2833

Figure 9. 144 MHz/x12 Multiplier

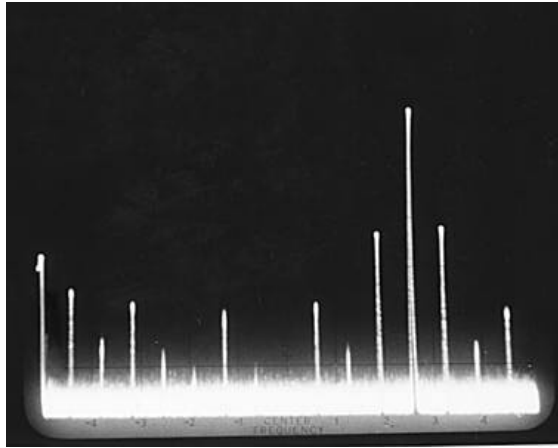

Figure 10. Circuit Side View

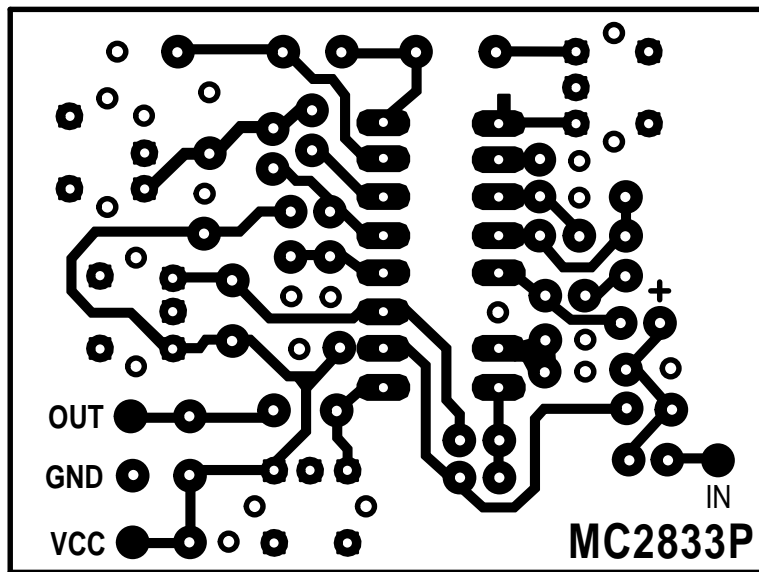
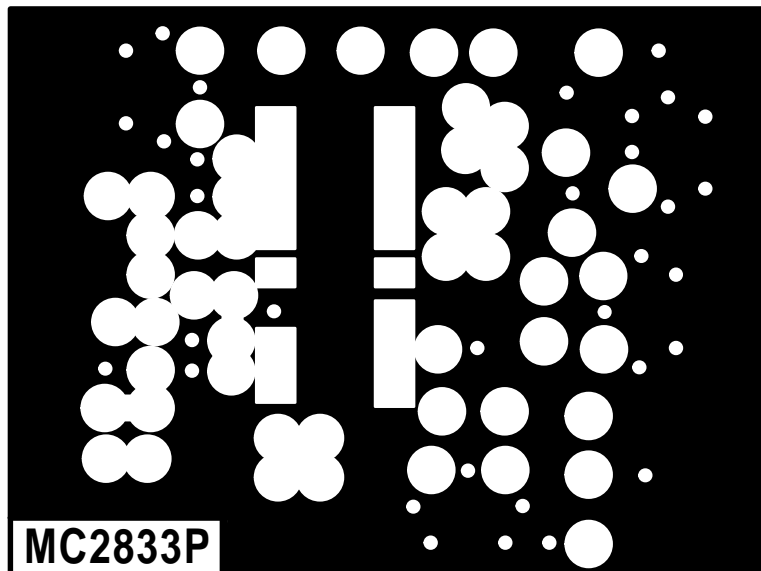
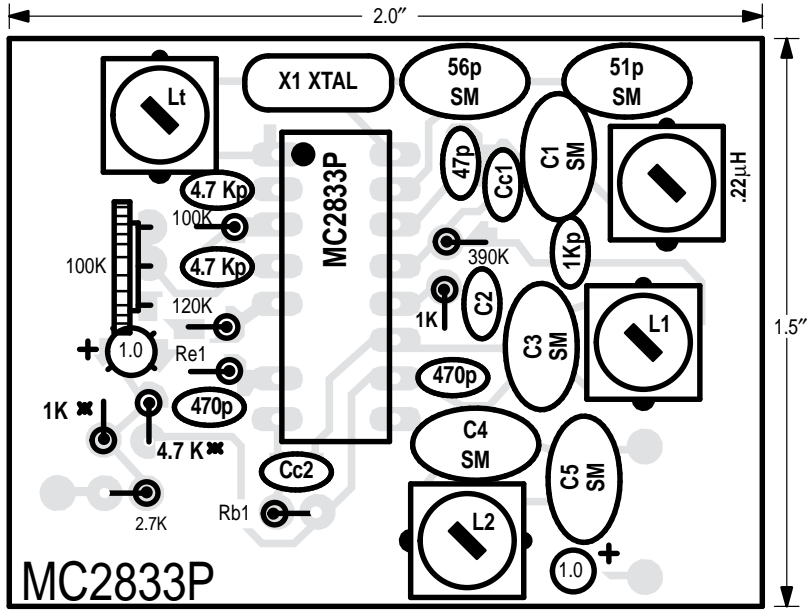

Figure 11. Ground Plane on Component Side



# MC2833

Figure 12. Component View



- NOTES:**
- Positive artwork provided.
  - Drill holes must be plated to ensure making all ground ( $V_{EE}$ ) connections!
  - Resistors labelled \* are used for biasing of electret microphone if used.
  - Capacitors labelled "SM" are silver mica.
  - Final board size 1.5" × 2.0".

Figure 13. Circuit Schematic

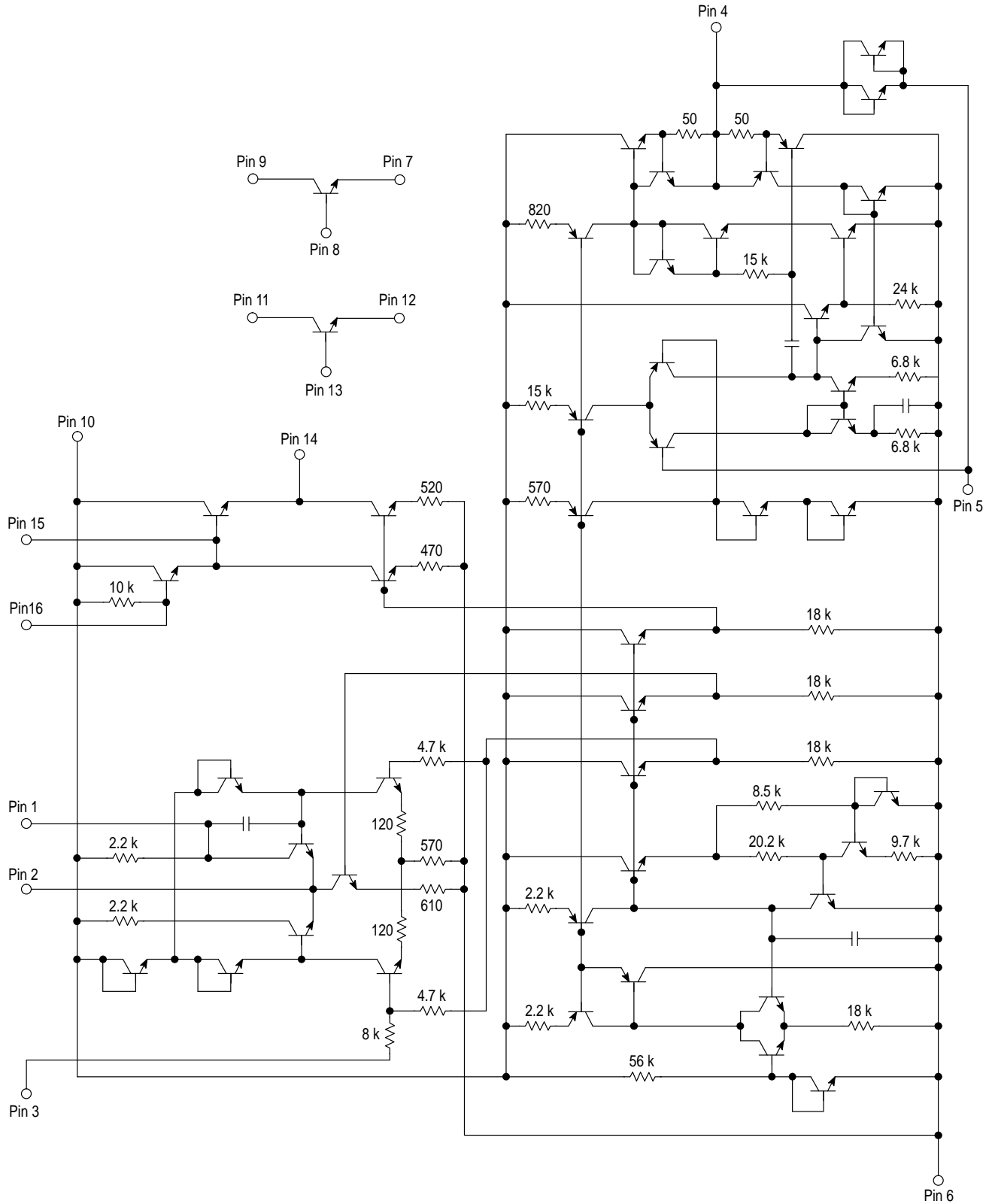

OUTLINE DIMENSIONS

**P SUFFIX**  
**PLASTIC PACKAGE**  
**CASE 648-08**  
**ISSUE R**

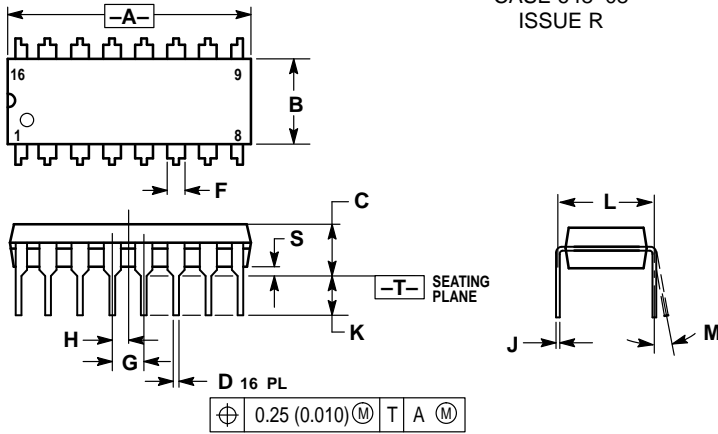

- NOTES:
1. DIMENSIONING AND TOLERANCING PER ANSI Y14.5M, 1982.
  2. CONTROLLING DIMENSION: INCH.
  3. DIMENSION L TO CENTER OF LEADS WHEN FORMED PARALLEL.
  4. DIMENSION B DOES NOT INCLUDE MOLD FLASH.
  5. ROUNDED CORNERS OPTIONAL.

DIM	INCHES		MILLIMETERS	
	MIN	MAX	MIN	MAX
A	0.740	0.770	18.80	19.55
B	0.250	0.270	6.35	6.85
C	0.145	0.175	3.69	4.44
D	0.015	0.021	0.39	0.53
F	0.040	0.70	1.02	1.77
G	0.100 BSC		2.54 BSC	
H	0.050 BSC		1.27 BSC	
J	0.008	0.015	0.21	0.38
K	0.110	0.130	2.80	3.30
L	0.295	0.305	7.50	7.74
M	0°		10°	
S	0.020	0.040	0.51	1.01

**D SUFFIX**  
**PLASTIC PACKAGE**  
**CASE 751B-05**  
**(SO-16)**  
**ISSUE J**

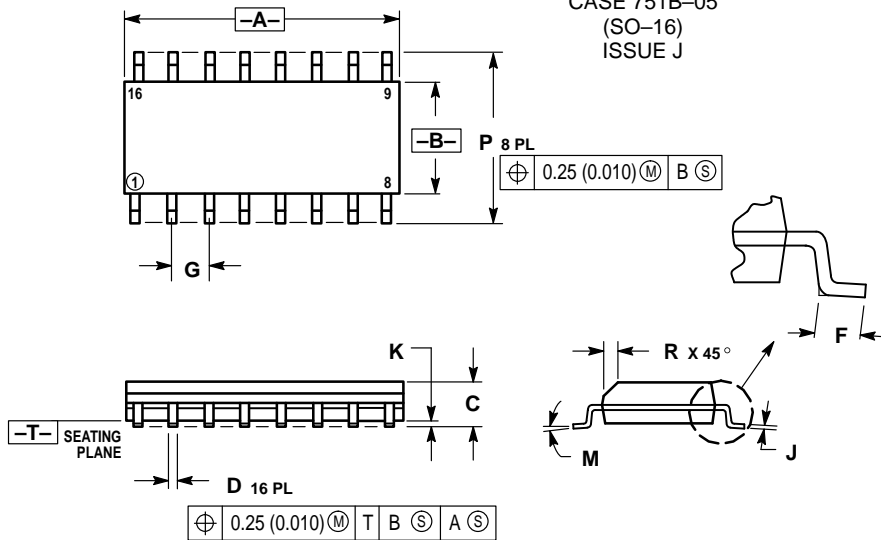

- NOTES:
1. DIMENSIONING AND TOLERANCING PER ANSI Y14.5M, 1982.
  2. CONTROLLING DIMENSION: MILLIMETER.
  3. DIMENSIONS A AND B DO NOT INCLUDE MOLD PROTRUSION.
  4. MAXIMUM MOLD PROTRUSION 0.15 (0.006) PER SIDE.
  5. DIMENSION D DOES NOT INCLUDE DAMBAR PROTRUSION. ALLOWABLE DAMBAR PROTRUSION SHALL BE 0.127 (0.005) TOTAL IN EXCESS OF THE D DIMENSION AT MAXIMUM MATERIAL CONDITION.

DIM	MILLIMETERS		INCHES	
	MIN	MAX	MIN	MAX
A	9.80	10.00	0.386	0.393
B	3.80	4.00	0.150	0.157
C	1.35	1.75	0.054	0.068
D	0.35	0.49	0.014	0.019
F	0.40	1.25	0.016	0.049
G	1.27 BSC		0.050 BSC	
J	0.19	0.25	0.008	0.009
K	0.10	0.25	0.004	0.009
M	0°		7°	
P	5.80	6.20	0.229	0.244
R	0.25	0.50	0.010	0.019

Motorola reserves the right to make changes without further notice to any products herein. Motorola makes no warranty, representation or guarantee regarding the suitability of its products for any particular purpose, nor does Motorola assume any liability arising out of the application or use of any product or circuit, and specifically disclaims any and all liability, including without limitation consequential or incidental damages. "Typical" parameters can and do vary in different applications. All operating parameters, including "Typicals" must be validated for each customer application by customer's technical experts. Motorola does not convey any license under its patent rights nor the rights of others. Motorola products are not designed, intended, or authorized for use as components in systems intended for surgical implant into the body, or other applications intended to support or sustain life, or for any other application in which the failure of the Motorola product could create a situation where personal injury or death may occur. Should Buyer purchase or use Motorola products for any such unintended or unauthorized application, Buyer shall indemnify and hold Motorola and its officers, employees, subsidiaries, affiliates, and distributors harmless against all claims, costs, damages, and expenses, and reasonable attorney fees arising out of, directly or indirectly, any claim of personal injury or death associated with such unintended or unauthorized use, even if such claim alleges that Motorola was negligent regarding the design or manufacture of the part. Motorola and  $\mu$  are registered trademarks of Motorola, Inc. Motorola, Inc. is an Equal Opportunity/Affirmative Action Employer.

**How to reach us:**

**USA/EUROPE:** Motorola Literature Distribution;  
 P.O. Box 20912; Phoenix, Arizona 85036. 1-800-441-2447

**JAPAN:** Nippon Motorola Ltd.; Tatsumi-SPD-JLDC, Toshikatsu Otsuki,  
 6F Seibu-Butsuryu-Center, 3-14-2 Tatsumi Koto-Ku, Tokyo 135, Japan. 03-3521-8315

**MFAX:** RMFAX0@email.sps.mot.com - TOUCHTONE (602) 244-6609  
**INTERNET:** http://Design-NET.com

**HONG KONG:** Motorola Semiconductors H.K. Ltd.; 8B Tai Ping Industrial Park,  
 51 Ting Kok Road, Tai Po, N.T., Hong Kong. 852-26629298

