

MOTOROLA
SEMICONDUCTOR
TECHNICAL DATA

HIGH VOLTAGE, HIGH CURRENT
DARLINGTON TRANSISTOR ARRAYS

The seven NPN Darlington connected transistors in these arrays are well suited for driving lamps, relays, or printer hammers in a variety of industrial and consumer applications. Their high breakdown voltage and internal suppression diodes insure freedom from problems associated with inductive loads. Peak inrush currents to 600 mA permit them to drive incandescent lamps.

The MC1411,B device is a general purpose array for use with DTL, TTL, PMOS, or CMOS Logic. The MC1412,B contains a zener diode and resistor in series with the input to limit input current for use with 14 to 25 Volt PMOS Logic. The MC1413,B with a 2.7 kΩ series input resistor is well suited for systems utilizing a 5 Volt TTL or CMOS Logic. The MC1416,B uses a series 10.5 kΩ resistor and is useful in 8 to 18 Volt MOS systems.

MAXIMUM RATINGS ($T_A = 25^\circ\text{C}$ and rating apply to any one device in the package unless otherwise noted)

Rating	Symbol	Value	Unit
Output Voltage	V_O	50	V
Input Voltage (Except MC1411)	V_I	30	V
Collector Current — Continuous	I_C	500	mA
Base Current — Continuous	I_B	25	mA
Operating Ambient Temperature Range	T_A	-20 to +85 -40 to +85	$^\circ\text{C}$
Storage Temperature Range	T_{stg}	-55 to +150	$^\circ\text{C}$
Junction Temperature	T_J	150	$^\circ\text{C}$
Thermal Resistance — Junction-to-Ambient	θ_{JA}	67 100	$^\circ\text{C/W}$
Case 648, P Suffix			
Case 751B, D Suffix			

ORDERING INFORMATION

Plastic DIP	SOIC	Ambient Temperature Range
MC1411P (ULN2001A) MC1412P (ULN2002A) MC1413P (ULN2003A) MC1416P (ULN2004A)	MC1411D MC1412D MC1413D MC1416D	-20° to +85°C
MC1411BP MC1412BP MC1413BP MC1416BP	MC1411BD MC1412BD MC1413BD MC1416BD	-40° to +85°C

MC1411,B
MC1412,B
MC1413,B
MC1416,B

PERIPHERAL
DRIVER ARRAYS

SILICON MONOLITHIC
INTEGRATED CIRCUITS

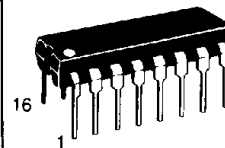

P SUFFIX
PLASTIC PACKAGE
CASE 648

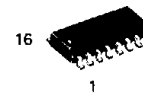

D SUFFIX
PLASTIC PACKAGE
CASE 751B
(SO-16)

7

PIN CONNECTIONS

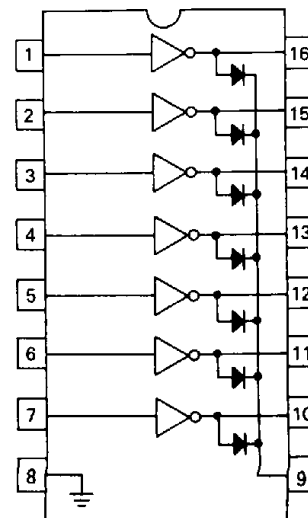

MC1411,B, MC1412,B, MC1413,B, MC1416,B

ELECTRICAL CHARACTERISTICS ($T_A = 25^\circ\text{C}$ unless otherwise noted)

Characteristic		Symbol	Min	Typ	Max	Unit
Output Leakage Current ($V_O = 50\text{ V}$, $T_A = +85^\circ\text{C}$) ($V_O = 50\text{ V}$, $T_A = +25^\circ\text{C}$) ($V_O = 50\text{ V}$, $T_A = +85^\circ\text{C}$, $V_I = 6.0\text{ V}$) ($V_O = 50\text{ V}$, $T_A = +85^\circ\text{C}$, $V_I = 1.0\text{ V}$)	All Types All Types MC1412,B MC1416,B	I_{CEX}	— — — —	— — — —	100 50 500 500	μA
Collector-Emitter Saturation Voltage ($I_C = 350\text{ mA}$, $I_B = 500\text{ }\mu\text{A}$) ($I_C = 200\text{ mA}$, $I_B = 350\text{ }\mu\text{A}$) ($I_C = 100\text{ mA}$, $I_B = 250\text{ }\mu\text{A}$)	All Types All Types All Types	$V_{CE(sat)}$	— — —	1.1 0.95 0.85	1.6 1.3 1.1	V
Input Current — On Condition ($V_I = 17\text{ V}$) ($V_I = 3.85\text{ V}$) ($V_I = 5.0\text{ V}$) ($V_I = 12\text{ V}$)	MC1412,B MC1413,B MC1416,B MC1416,B	$I_{I(on)}$	— — — —	0.85 0.93 0.35 1.0	1.3 1.35 0.5 1.45	mA
Input Voltage — On Condition ($V_{CE} = 2.0\text{ V}$, $I_C = 300\text{ mA}$) ($V_{CE} = 2.0\text{ V}$, $I_C = 200\text{ mA}$) ($V_{CE} = 2.0\text{ V}$, $I_C = 250\text{ mA}$) ($V_{CE} = 2.0\text{ V}$, $I_C = 300\text{ mA}$) ($V_{CE} = 2.0\text{ V}$, $I_C = 125\text{ mA}$) ($V_{CE} = 2.0\text{ V}$, $I_C = 200\text{ mA}$) ($V_{CE} = 2.0\text{ V}$, $I_C = 275\text{ mA}$) ($V_{CE} = 2.0\text{ V}$, $I_C = 350\text{ mA}$)	MC1412,B MC1413,B MC1413,B MC1413,B MC1416,B MC1416,B MC1416,B MC1416,B	$V_{I(on)}$	— — — — — — — —	— — — — — — — —	13 2.4 2.7 3.0 5.0 6.0 7.0 8.0	V
Input Current — Off Condition ($I_C = 500\text{ }\mu\text{A}$, $T_A = +85^\circ\text{C}$)	All Types	$I_{I(off)}$	50	100	—	μA
DC Current Gain ($V_{CE} = 2.0\text{ V}$, $I_C = 350\text{ mA}$)	MC1411,B	h_{FE}	1000	—	—	—
Input Capacitance		C_I	—	15	30	pF
Turn-On Delay Time (50% E_I to 50% E_O)		t_{on}	—	0.25	1.0	μs
Turn-Off Delay Time (50% E_I to 50% E_O)		t_{off}	—	0.25	1.0	μs
Clamp Diode Leakage Current ($V_R = 50\text{ V}$)	$T_A = +25^\circ\text{C}$ $T_A = +85^\circ\text{C}$	I_R	— —	— —	50 100	μA
Clamp Diode Forward Voltage ($I_F = 350\text{ mA}$)		V_F	—	1.5	2.0	V

TYPICAL PERFORMANCE CURVES — $T_A = 25^\circ\text{C}$

FIGURE 1 — OUTPUT CURRENT versus INPUT VOLTAGE

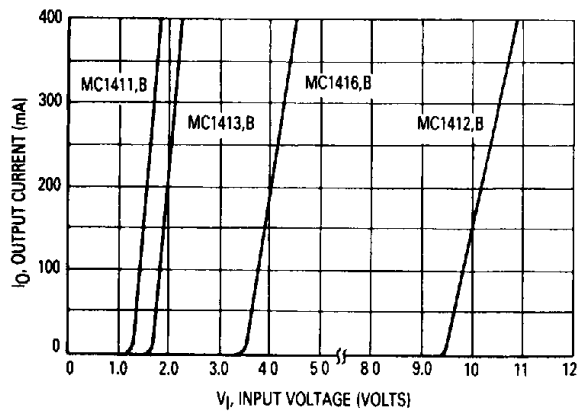
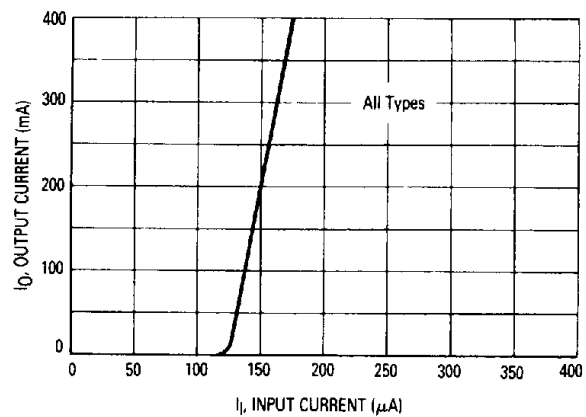

FIGURE 2 — OUTPUT CURRENT versus INPUT CURRENT



MC1411,B, MC1412,B, MC1413,B, MC1416,B

TYPICAL CHARACTERISTIC CURVES - $T_A = 25^\circ\text{C}$ (continued)

FIGURE 3 — TYPICAL OUTPUT CHARACTERISTICS

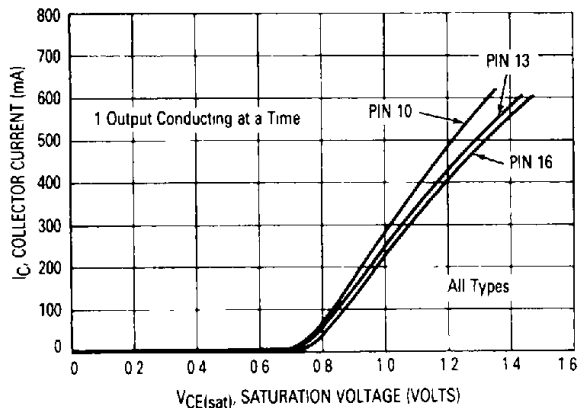

FIGURE 4 — INPUT CHARACTERISTICS — MC1412,B

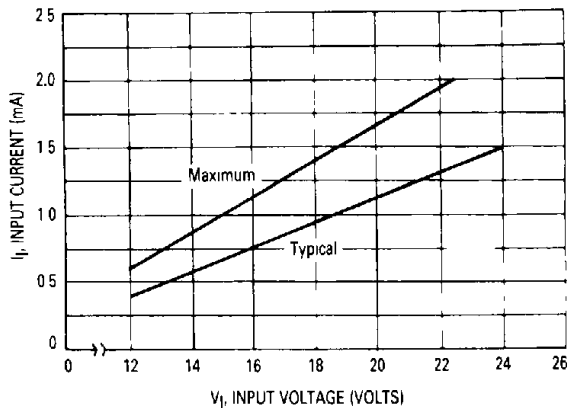

FIGURE 5 — INPUT CHARACTERISTICS — MC1413,B

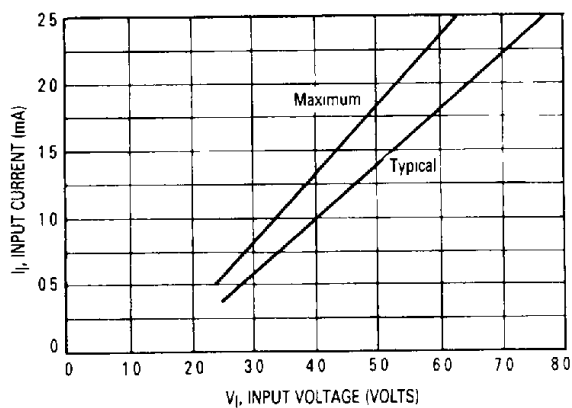

FIGURE 6 — INPUT CHARACTERISTICS — MC1416,B

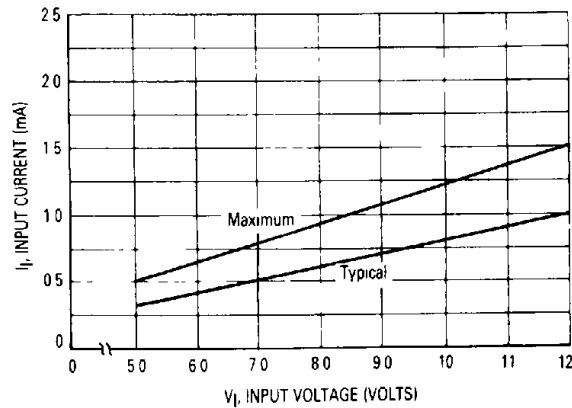
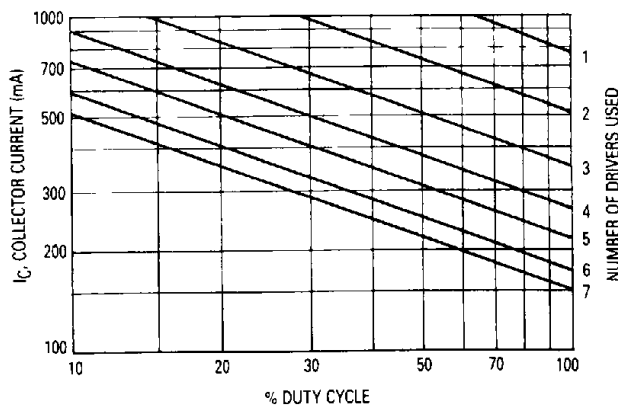

FIGURE 7 — MAXIMUM COLLECTOR CURRENT versus DUTY CYCLE (AND NUMBER OF DRIVERS IN USE)



7

MC1411,B, MC1412,B, MC1413,B, MC1416,B

FIGURE 8 — REPRESENTATIVE CIRCUIT SCHEMATICS

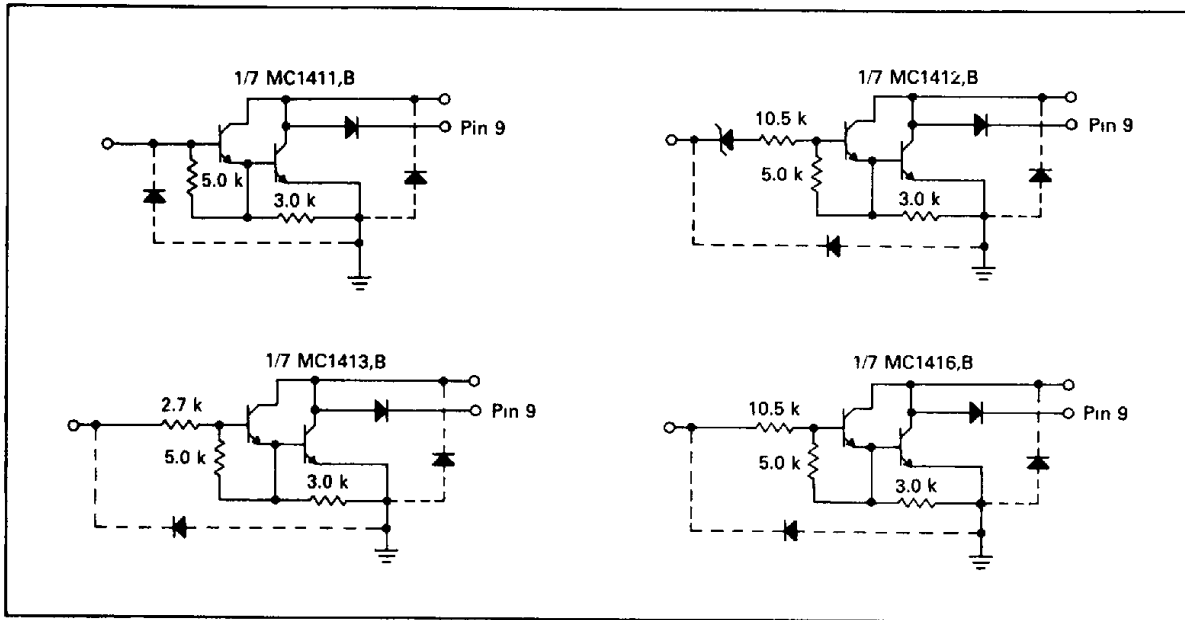

7