

HA12005

Low Noise Amplifier & Electronic Switching for Cassette Tape Deck

The HA12005 is designed for electronic-controlled cassette deck system, including Pre-Amp., Mic Amp., and Dolby noise reduction circuit switch. Its features are as follows.

■ FEATURES

- Built-in Mic Amp., Pre Amp., and REC/PLY Amp.
- Built-in switch to control Encode and Decode mode of the Dolby circuit
- Electronic switching system

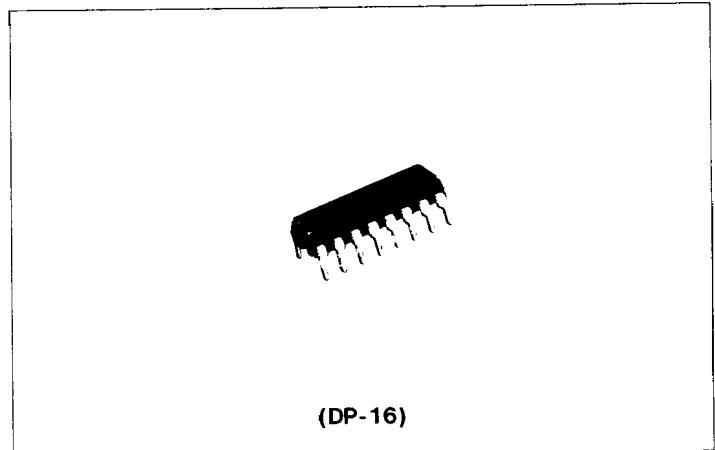

■ BLOCK DIAGRAM

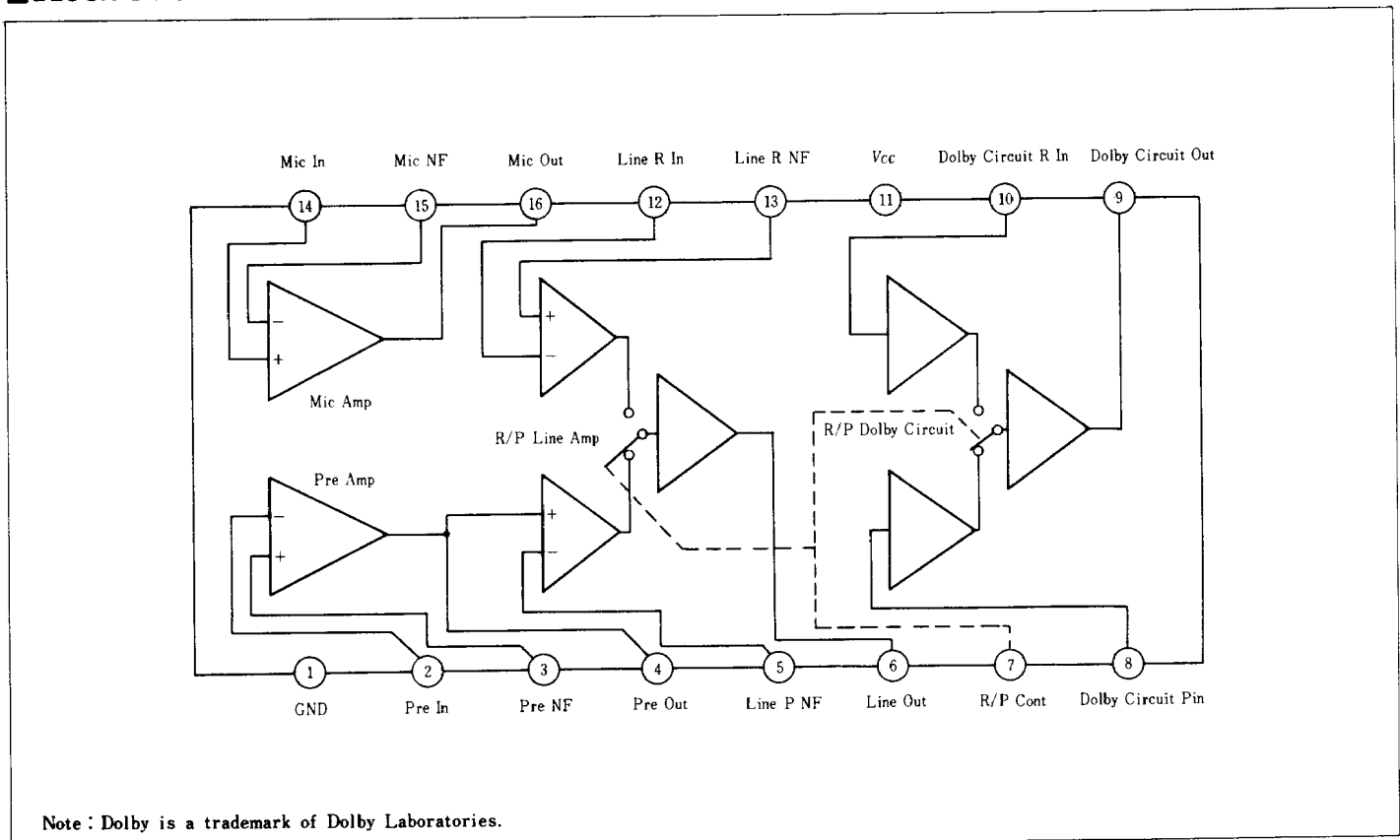

■ ABSOLUTE MAXIMUM RATINGS (Unless otherwise specified, $T_a=25^\circ\text{C}$)

Item	Symbol	Rating	Unit
Supply Voltage	V_{CC}	15.0	V
Power Dissipation*	P_T	300	mW
Operating Temperature Range	T_{opr}	-30 to +70	$^\circ\text{C}$
Storage Temperature Range	T_{stg}	-55 to +125	$^\circ\text{C}$

* Value at $T_a=70^\circ\text{C}$

■ BLOCK DIAGRAM FOR ELECTRONIC-CONTROLLED CASSETTE DECK SYSTEM
(R-ch peripheral circuit diagram omitted)

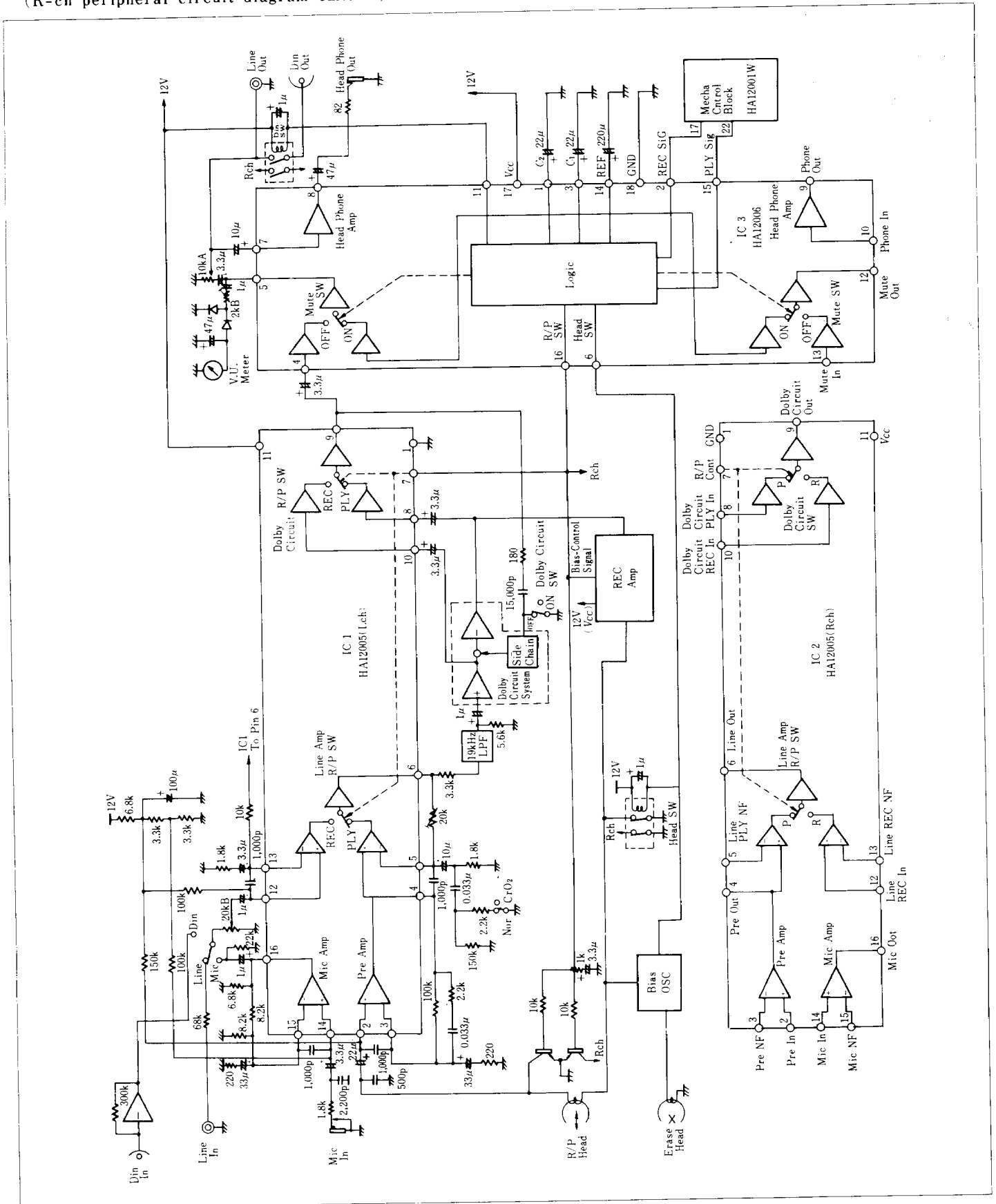

ELECTRICAL CHARACTERISTICS (Unless otherwise specified, $T_a=25^{\circ}\text{C}$, $V_{CC}=12\text{V}$, $f_i=1\text{kHz}$)

Item	Symbol	Test Conditions	min.	typ.	max.	Unit.
Quiescent Current	I_Q	No input signal	—	10	17	mA
Pre+PLY LINE Amp	Max Output Voltage	$(e_o \text{ MAX})_{PL}$ $T.H.D \leq 1\%$	1.2	2.0	—	Vrms
	Total Harmonic Distortion	$(T.H.D)_{PL}$ $e_{o \text{ PL}}=550\text{mVrms}$	—	0.1	0.5	%
	Noise Output Voltage	$(e_{on})_{PL}$ $V_{CC}=15\text{V}$, $R_g=2.4\text{k}\Omega$ 30Hz to 15kHz B.P.F. CCIR Filter	—	180	460	μVrms
	Pulse-form Noise Output Voltage	$(P_N)_{PL}$ $V_{CC}=15\text{V}$, $R_g=2.4\text{k}\Omega$, $t=5\text{sec}$. 30Hz to 15kHz, B.P.F.	—	1.8	5.0	mVpp
	Hum Rejection	$(H.R)_{PL}$ $f_i=100\text{Hz}$, $R_g=2.4\text{k}\Omega$	—	7.5	—	dB
Mic Amp	Max. Output Voltage	$(e_o \text{ MAX})_M$ $T.H.D \leq 1\%$	2.2	3.3	—	Vrms
	Total Harmonic Distortion	$(T.H.D)_M$ $e_{oM}=550\text{mVrms}$	—	0.1	0.5	%
	Noise Output Voltage	$(e_{on})_M$ $V_{CC}=15\text{V}$, $R_g=1.8\text{k}\Omega$ 30Hz to 15kHz B.P.F. CCIR Filter	—	31	70	μVrms
	Hum Rejection	$(H.R)_M$ $f_i=100\text{Hz}$, $R_g=1.8\text{k}\Omega$	—	45	100	dB
REC LINE Amp	Max. Output Voltage	$(e_o \text{ MAX})_L$ $T.H.D \leq 1\%$	1.2	2.0	—	Vrms
	Total Harmonic Distortion	$(T.H.D)_L$ $e_{oL}=550\text{mVrms}$	—	0.1	0.5	%
	Noise Output Voltage	$(e_{on})_L$ $V_{CC}=15\text{V}$, $R_g=15\text{k}\Omega$ 30Hz to 15kHz B.P.F. CCIR Filter	—	15	31	μVrms
	Hum Rejection	$(H.R)_L$ $f_i=100\text{Hz}$, $R_g=15\text{k}\Omega$	—	45	50	dB
DOLBY Circuit SW	Total Harmonic Distortion	$(T.H.D)_D$ $e_{oD}=550\text{mVrms}$, for both REC and PLY	—	0.1	0.5	%
SW	Leakage Voltage at REC/PLY Amp SW	e_{LL} Mic Amp IN=10mVrms, $R_g=0$ $f_o=1\text{kHz}$, 1/3 Oct B.P.F.	—	20	125	μVrms
	Leakage Voltage at DOLBY REC/PLY SW	e_{LD} DOLBY CIRCUIT IN=2.7Vrms, $f_o=1\text{kHz}$, 1/3 Oct B.P.F. $R_g=10\Omega+3.3\mu\text{F}$	—	50	340	μVrms
	REC/PLY Switching Voltage level	REC PLY	PLY→REC REC→PLY	5	—	—
			—	—	2	V

Note 1. Tape select switch is connected to normal tape position.

2. Closed-loop Typical Voltage Gain ($f_i=1\text{kHz}$)

Mic Amp 31.3dB Pre + PLY LINE Amp 44.3dB REC LINE Amp 16.0dB DOLBY Circuit SW 0dB

TEST CIRCUIT

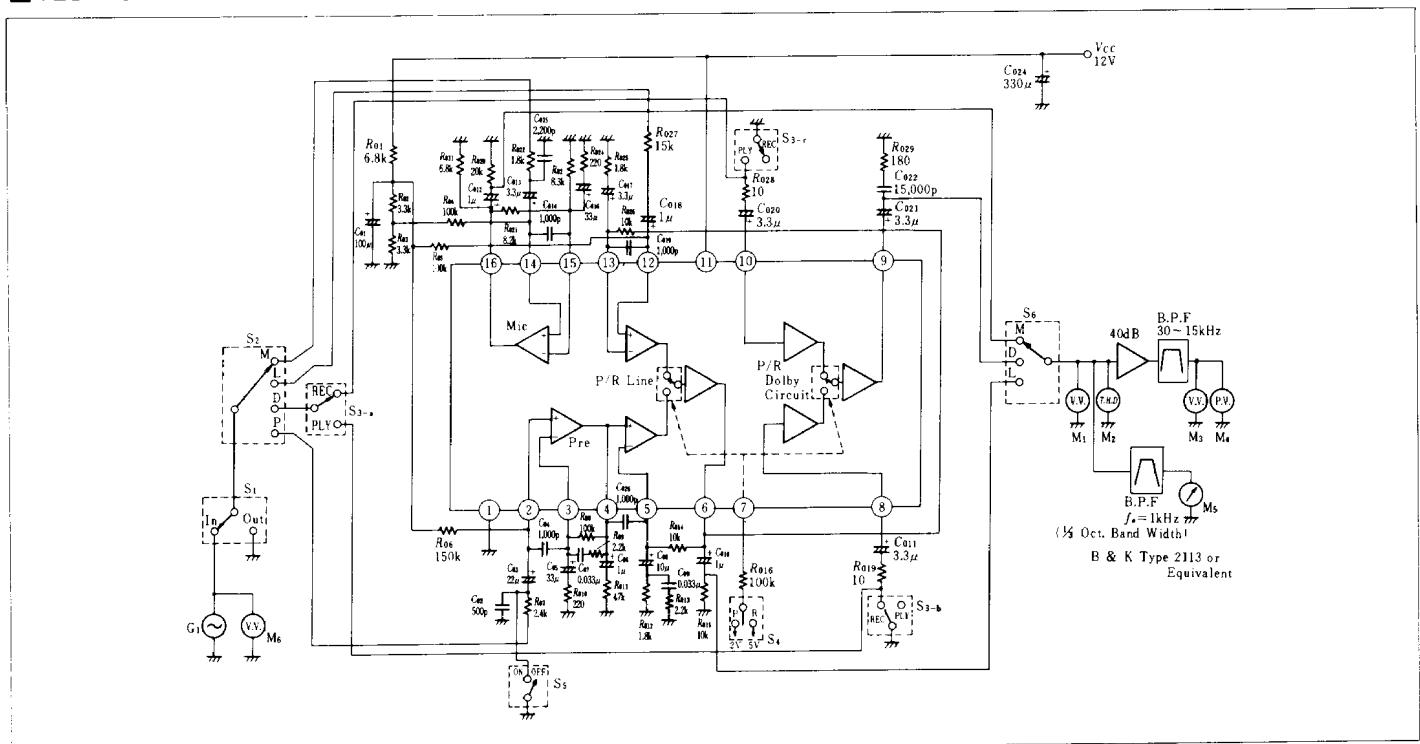

■ SWITCH POSITIONS FOR TEST CIRCUIT

Item	SW Position						Instrument
	S ₁	S ₂	S ₃	S ₄	S ₅	S ₆	
$(e_{on})_M^{*4}$	Out	M	*1	R	ON	M	M ₃
$(e_{on})_{PL}^{*4}$	Out	P	*1	P	OFF	L	M ₃
$(e_{on})_L^{*4}$	Out	L	*1	R	ON	L	M ₃
$(P_N)_{PL}^{*4}$	Out	P	*1	P	OFF	L	M ₄
$(e_o)_{MAX}^M$	In	M	*1	R	ON	M	M ₁
$(e_o)_{MAX}^{PL}$	In	P	*1	P	OFF	L	M ₁
$(e_o)_{MAX}^L$	In	L	*1	R	ON	L	M ₁
$(T.H.D)_{DP}^{*2}$	In	D	PLY	P	ON	D	M ₂
$(T.H.D)_{DR}^{*3}$	In	D	REC	R	ON	D	M ₂
$(T.H.D)_M$	In	M	*1	R	ON	M	M ₂
$(T.H.D)_{PL}$	In	P	*1	P	OFF	L	M ₂
$(T.H.D)_L$	In	L	*1	R	ON	L	M ₂
e_{LL}	In	M	*1	P	ON	L	M ₅
e_{LD}	In	D	PLY/REC	P/R	ON	D	M ₅

Notes : *1) REC or PLY
 *2) $(T.H.D)_{DP}$: Distortion at PLY
 *3) $(T.H.D)_{DR}$: Distortion at REC
 *4) For $(e_{on})_M$, $(e_{on})_{PL}$, $(e_{on})_L$ and $(P_N)_{PL}$, 1/100 of the pointed value adopted. (See ELECTRICAL CHARACTERISTICS.)

■ CAUTIONS FOR MEASUREMENT

1) For instrument accuracy, keep the ranges listed below.

Item		Range	Note
Audio Signal Generator (G ₁)	Distortion	0.05%	Under the frequency of 30Hz to 16kHz
	Output Impedance	600Ω	
Audio Voltmeter (M ₁ , M ₃)	Logarithm Scale	±1%	
External Resistor	Error	±1%	
Chemical Condensers	Error	±20%	Check the error range by measuring the instrument.
Condensers	Error	±10%	Except Chemical Condensers.

2) The following types of meter are recommended. Equivalents may be used.

Audio Voltmeter	(M ₁ , M ₂)	HP400EL
Pulse Noise Peak Meter	(M ₄)	PM-60(Toa-Dempa)
Distortion Meter	(M ₂)	Shibaden 870

3) Before measuring, check the output waveform for no induced-disturbance.

VOLTAGE GAIN OF MIC. AMP. VS. FREQUENCY

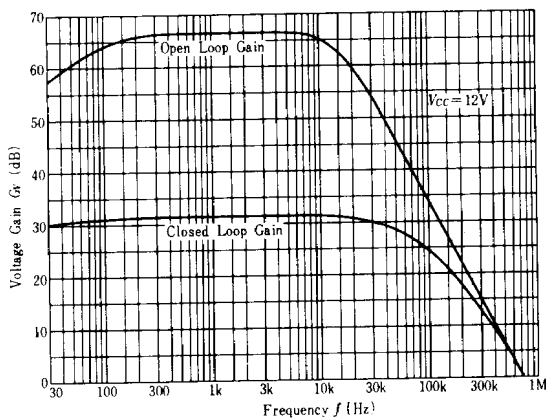

TOTAL HARMONIC DISTORTION OF MIC. AMP. VS. OUTPUT VOLTAGE

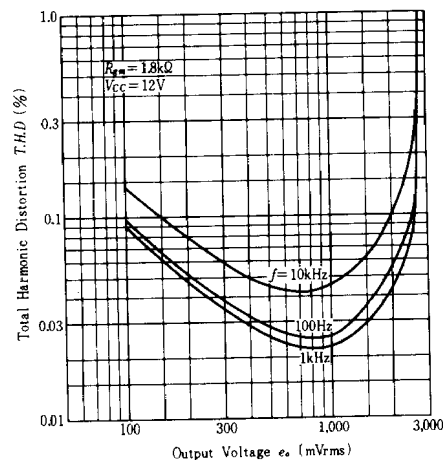

OUTPUT VOLTAGE OF MIC. AMP. VS. SUPPLY VOLTAGE

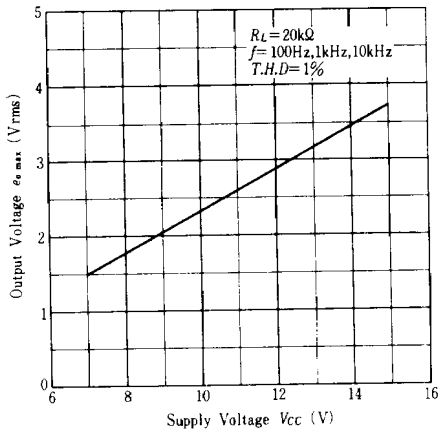

OUTPUT VOLTAGE OF MIC. AMP. VS. AMBIENT TEMPERATURE

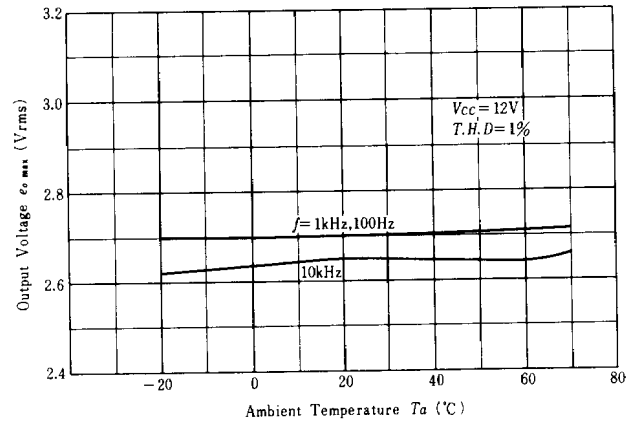

VOLTAGE GAIN OF PREAMP. VS. FREQUENCY

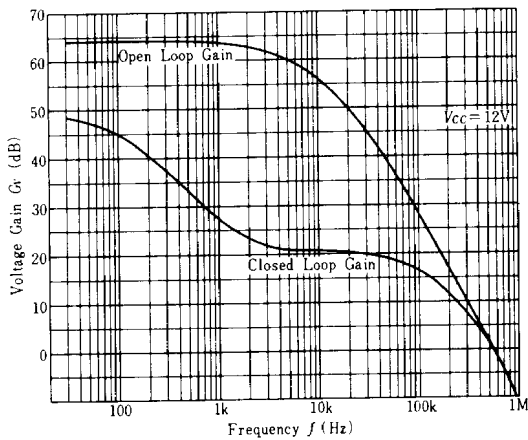

TOTAL HARMONIC DISTORTION OF PREAMP. VS. OUTPUT VOLTAGE

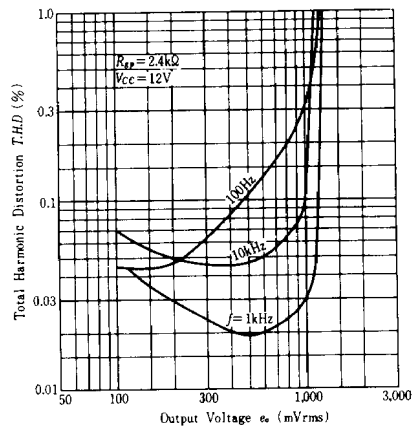

OUTPUT VOLTAGE OF PREAMP. VS. SUPPLY VOLTAGE

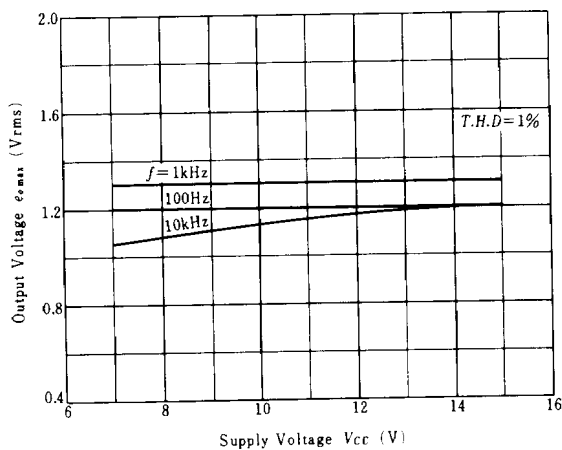

OUTPUT VOLTAGE OF PREAMP. VS. AMBIENT TEMPERATURE

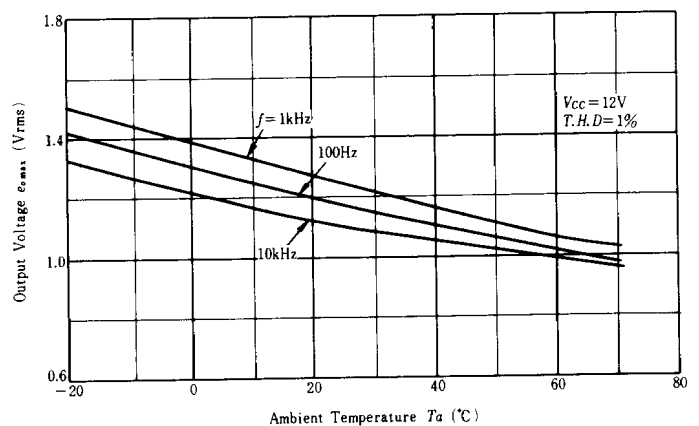

VOLTAGE GAIN OF LINE AMP. VS. FREQUENCY

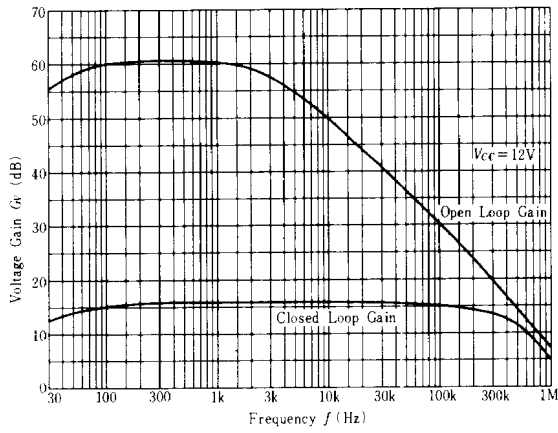

TOTAL HARMONIC DISTORTION OF LINE AMP(REC) VS. OUTPUT VOLTAGE

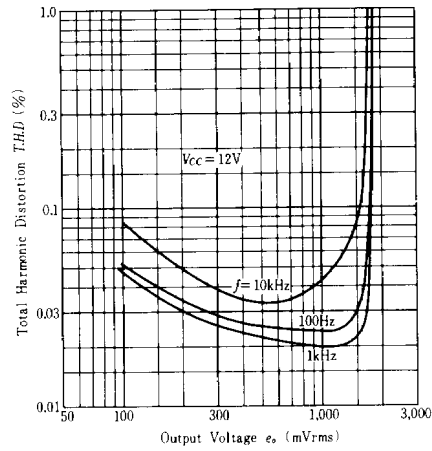

OUTPUT VOLTAGE OF LINE AMP.(REC) VS. AMBIENT TEMPERATURE

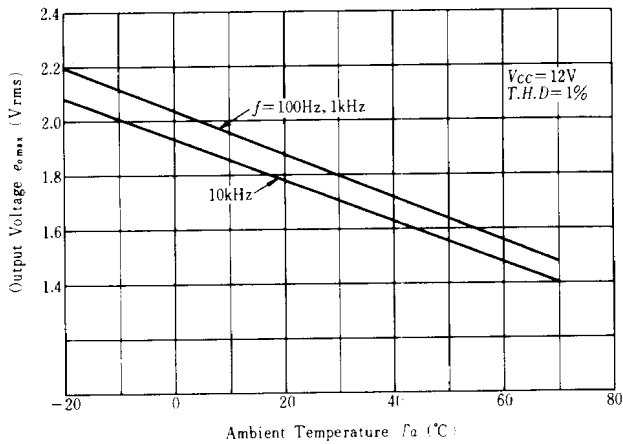

CLOSED LOOP VOLTAGE GAIN OF PREAMP. PLUS LINE AMP. VS. FREQUENCY

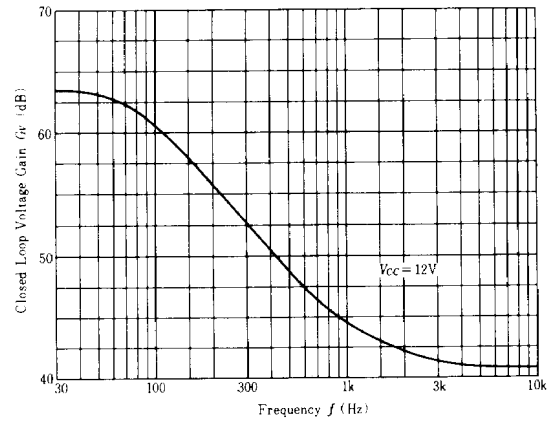

TOTAL HARMONIC DISTORTION OF PREAMP. PLUS LINE AMP. VS. OUTPUT VOLTAGE

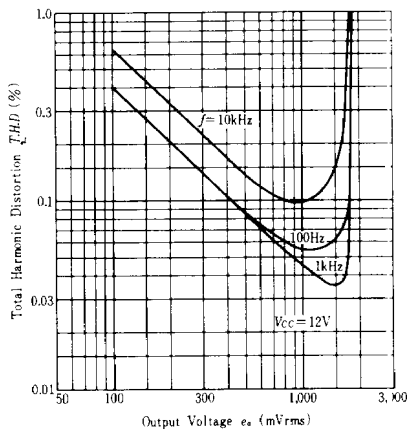

OUTPUT VOLTAGE OF PREAMP. PLUS LINE AMP. VS. SUPPLY VOLTAGE

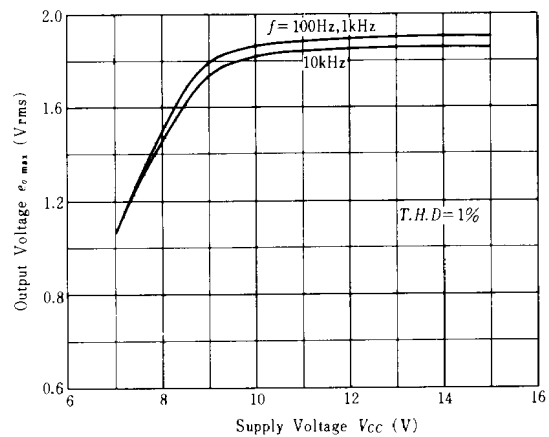

REC/PLY LEAK LEVEL VS. FREQUENCY

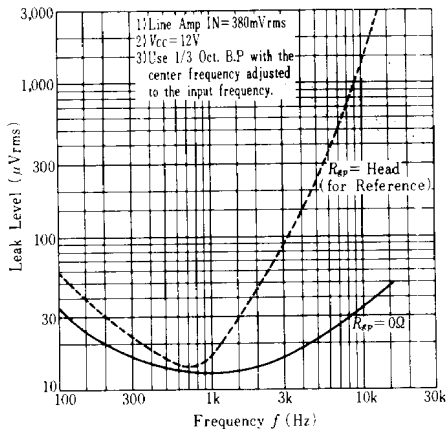

TOTAL HARMONIC DISTORTION OF DOLBY CIRCUIT SWITCH VS. OUTPUT VOLTAGE

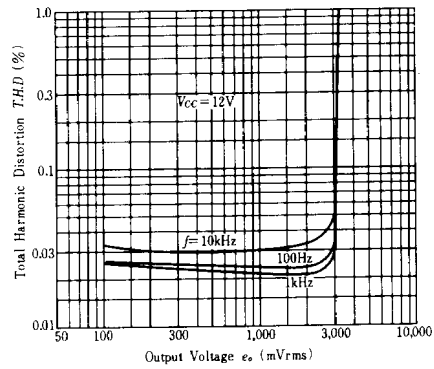

OUTPUT VOLTAGE OF R/P DOLBY CIRCUIT SWITCH VS. SUPPLY VOLTAGE

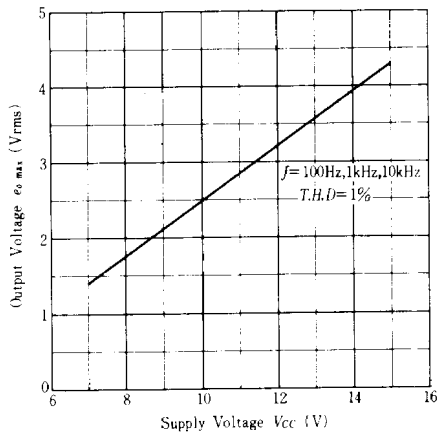

R/P LEAK LEVEL OF DOLBY CIRCUIT SWITCH VS. FREQUENCY

