

T-58-11-31

**4-Output Switching Regulator  
BA6121**

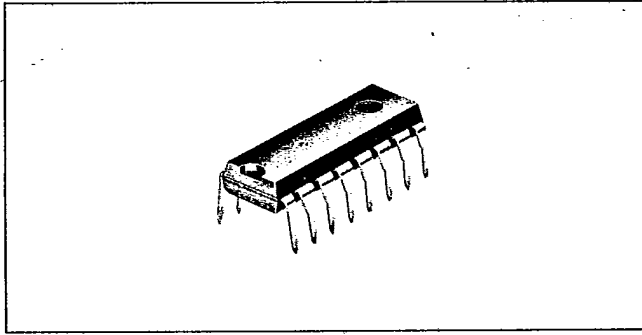

**Dimensions (Unit: mm)**

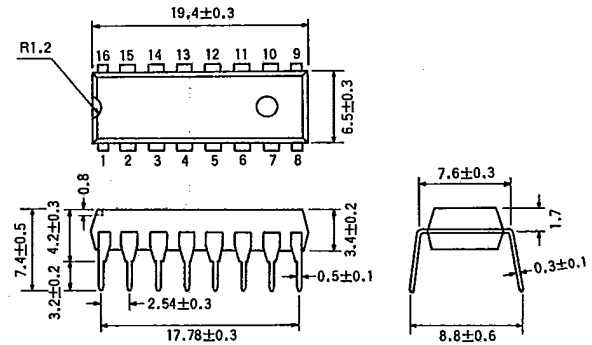

Fig. 1

The BA6121 is a monolithic switching regulator specifically designed for use in VCRs. The device contains four PWM (pulse-width modulated) switching regulator blocks with REF control, drivability control, and feedback limiting pins. The device also contains an error input pin for each block. With four blocks of switching regulators and a power save pin to reduce current consumption, the device is particularly suitable for compact power supply design in portable VCRs.

**Features**

1. Four switching regulator blocks implemented on a single chip.
2. Power save pin enables only one regulator output.
3. External reference voltage control can make the device a variable voltage supply.
4. The drivability control pin allows the user to set the drain current at pin 1 to enable driving at a minimum power.

**Block Diagram**

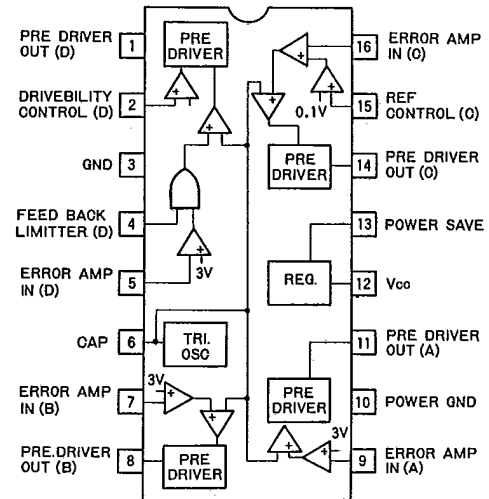

Fig. 2

**Absolute Maximum Ratings (Ta=25°C)**

| Parameter                    | Symbol           | Limits  | Unit |
|------------------------------|------------------|---------|------|
| Supply voltage               | V <sub>CC</sub>  | 18      | V    |
| Power dissipation            | P <sub>d</sub>   | 400*    | mW   |
| Operating temperature range  | T <sub>opr</sub> | -20~75  | °C   |
| Storage temperature range    | T <sub>stg</sub> | -55~125 | °C   |
| Maximum sink current, pin 11 | I <sub>11</sub>  | 30      | mA   |
| Maximum sink current, pin 8  | I <sub>8</sub>   | 10      | mA   |
| Maximum sink current, pin 14 | I <sub>14</sub>  | 20      | mA   |
| Maximum drain current, pin 1 | I <sub>1</sub>   | 1       | mA   |

\*Derating is done at 4mW/°C for operation above Ta=25°C.

Electrical Characteristics (Unless otherwise specified,  $T_a=25^\circ\text{C}$ ,  $V_{CC}=12\text{V}$ )

| Parameter                             | Symbol   | Min. | Typ. | Max. | Unit          | Conditions           |
|---------------------------------------|----------|------|------|------|---------------|----------------------|
| Supply voltage range                  | $V_{CC}$ | 8    | —    | 16   | V             | —                    |
| Quiescent current                     | $I_Q$    | 8.0  | 11.6 | 15.0 | mA            | —                    |
| Triangular wave oscillation frequency | $f_s$    | 25   | 39   | 57   | kHz           | $C_T=1500\text{pF}$  |
| Drain current, pin 15                 | $I_{15}$ | —    | 30   | —    | $\mu\text{A}$ | —                    |
| Drain current, pin 2                  | $I_2$    | —    | 30   | —    | $\mu\text{A}$ | —                    |
| Drain current, pin 4                  | $I_4$    | —    | 200  | —    | $\mu\text{A}$ | —                    |
| Drain current, pin 13                 | $I_{13}$ | —    | 0.3  | —    | mA            | 13pin= $L_O$         |
| Sink current, pin 9                   | $I_9$    | —    | —    | 5    | $\mu\text{A}$ | $V_9=3.1\text{V}$    |
| Sink current, pin 7                   | $I_7$    | —    | —    | 5    | $\mu\text{A}$ | $V_7=3.1\text{V}$    |
| Sink current, pin 16                  | $I_{16}$ | —    | —    | 5    | $\mu\text{A}$ | $V_{16}=3.1\text{V}$ |
| Sink current, pin 5                   | $I_5$    | —    | —    | 5    | $\mu\text{A}$ | $V_5=3.1\text{V}$    |

Electrical Characteristic Curves

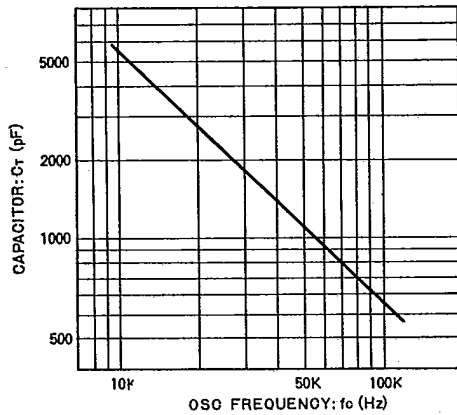

Fig. 3 Capacitor vs. OSC frequency

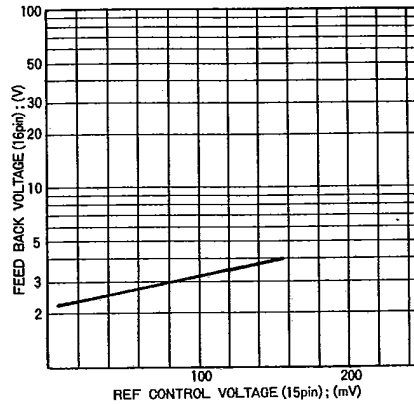

Fig. 4 Feed back voltage vs. REF control voltage

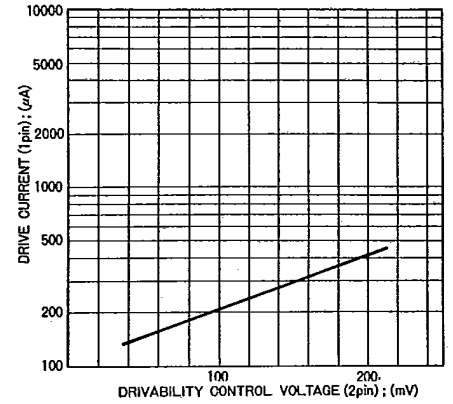

Fig. 5 Drive current vs. drivability control voltage

Application Example

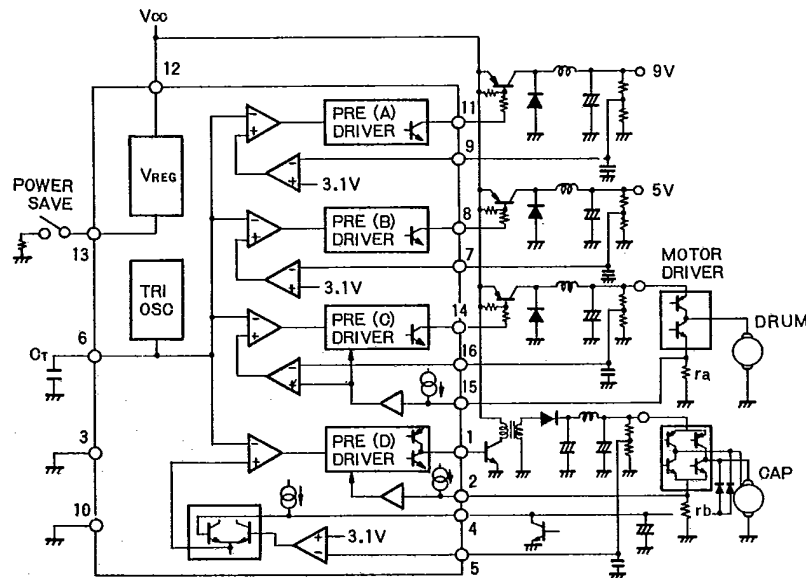

Fig. 6

### Circuit Description (See Fig. 6)

#### 1. Triangular wave oscillator

The oscillation frequency ( $f_s$ ) of this oscillator (which can be controlled with an external capacitor connected to pin 6) is given by the following formula:

$$f_s = 1/T = 1(17.5 \times 10^3 \times C) \text{ [Hz]}$$

#### 2. Block A

The output voltage on block A is controlled so that the feedback input (pin 9) is set to 3.1 V (typ.). The PWM duty cycle is from 0 to 100%. The maximum sink current into pin 11 is 30 mA. Pin 11 can be turned off by

setting the power save pin (pin 13) low.

#### 3. Block B

The output voltage on block B is controlled so that the feedback input (pin 7) is set to 3.1 V (typ.). The PWM duty cycle is from 0 to 100%. The maximum sink current into pin 8 is 10 mA. This block continues to be active even if the power save pin is set low.

#### 4. Block C

This block has a REF control input. The PWM duty cycle is 20 to 100% (typ.). Fig. 4 shows a REF control

voltage (pin 15) versus feedback voltage (pin 16) curve.

Pin 14 can be turned off by setting the power save pin (pin 13) low.

#### 5. Block D

This block has drivability control and low-voltage limiting inputs. The PWM duty cycle is 30 to 60% (typ.). Fig. 5 shows a drivability control voltage (pin 2) versus drain current (at pin 1) curve.

Pin 1 can be turned off by setting the power save pin (pin 13) low.

### Applications to Power Supply

#### 1. 9 V voltage regulator

Block A in Fig. 6 constitutes a voltage-drop type chopper regulator. Since the maximum sink current into pin 11 is 30 mA, this block is suitable in power source applications not only for signal systems but also for motor driving. The efficiency is a high 90%.

#### 2. 5 V voltage regulator

Block B in Fig. 6 constitutes a voltage-drop type chopper regulator. This block is best suited for a system power supply as it continues to be active regardless of the power save pin status.

#### 3. Variable power source for drum motors

Block C in Fig. 6 provides a voltage-drop type chopper regulator. The motor current is detected by a small resistor ( $r_a$ ), and the voltage appearing across this resistor is used to control the REF voltage, which then controls the output voltage of the regulator according to the motor current.

This driving scheme allows only the necessary minimum power to be supplied to the motor in the steady state, so that driving power can be saved without sacrificing starting torque.

#### 4. Variable power source for capstan motor

Block D is used as an inverter-type variable voltage regulator intended to provide an elevated voltage for the special playback mode on the VCR. The diodes and capacitor at pin 4 regulate the Vce voltage of the motor driving transistors and control the supply voltage to the required minimum. The small resistor ( $r_b$ ) used to detect the motor current controls the drain current at pin 1. The maximum output voltage is made available by grounding pin 4.