

HA11215A

Color TV Picture IF System

FUNCTIONS

- PIF Amplifier
- Video Detector
- AFC with Defeat
- Noise Canceller
- Forward AGC

FEATURES

- SAW filter connectable without pre-amp.
- Input sensitivity: $V_{in} = 50\mu V_{rms}$ typ.
- Output peak-to-peak voltage at video detector adjustable externally.
- High S/N under weak-input signal.

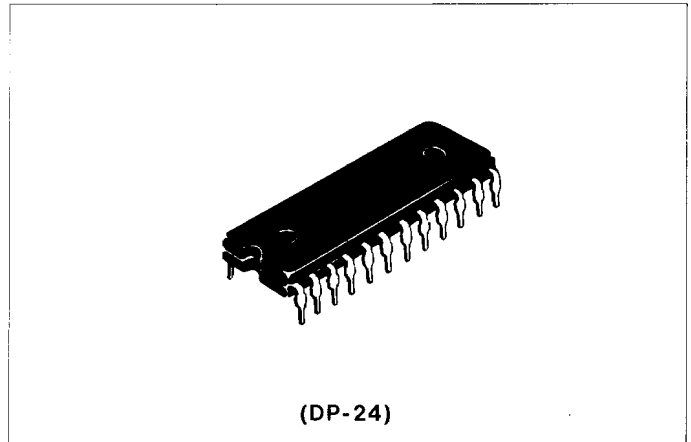

BLOCK DIAGRAM

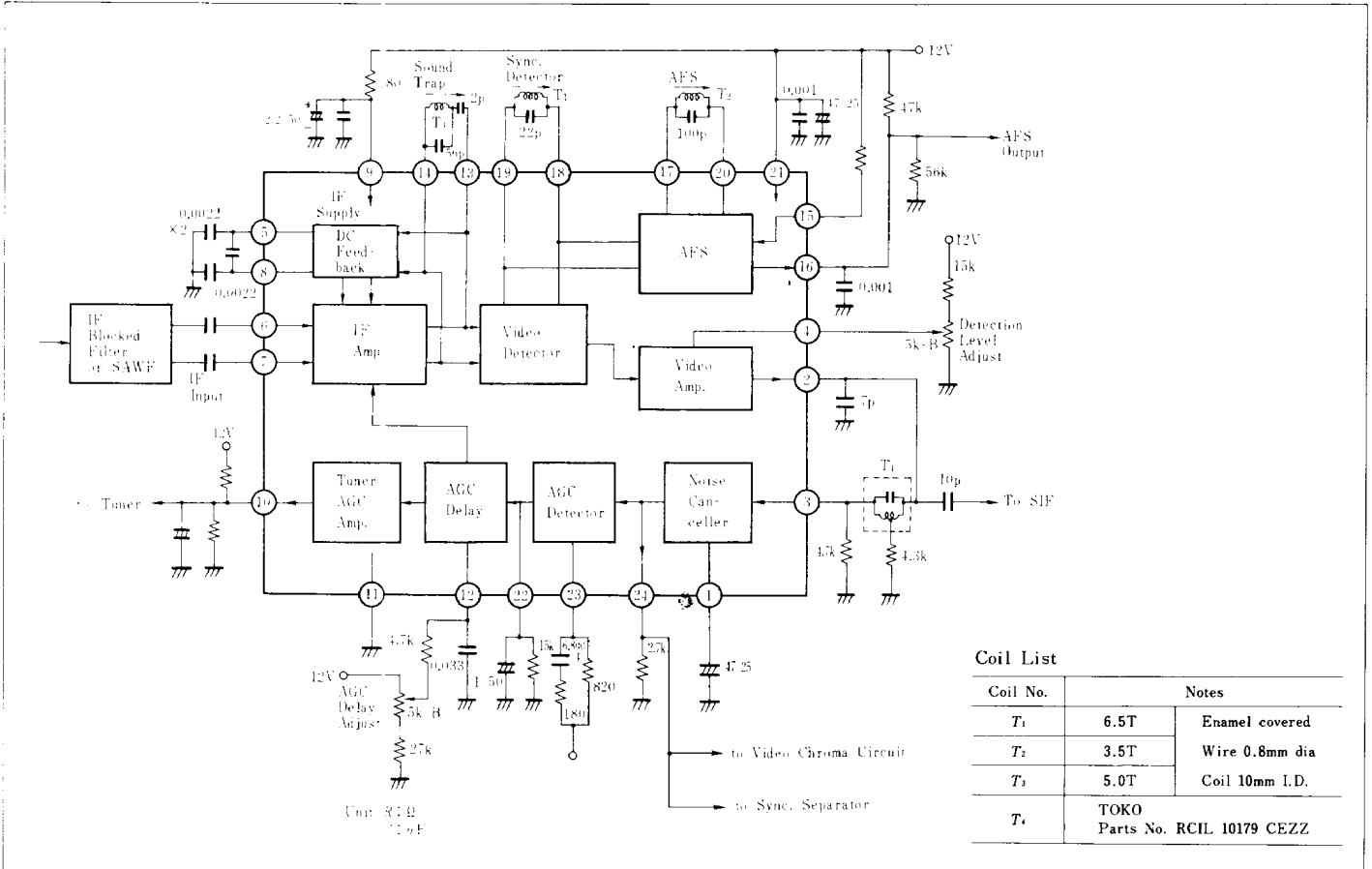

ABSOLUTE MAXIMUM RATINGS ($T_a = 25^\circ C$ unless otherwise specified)

Item	Symbol	Rated	Unit
Supply Voltage	V_{cc}	15	V
Input Voltage	V_{in}	5	V _{p-p}
Power Dissipation	P_T	625*	mW
Operating Temperature	T_{opr}	-20 to +75	$^\circ C$
Storage Temperature	T_{stg}	-40 to +125	$^\circ C$

* Value at $T_a = 75^\circ C$

ELECTRICAL CHARACTERISTICS ($V_{CC}=12V$, $T_a=25^\circ C$)

Item	Symbol	Test Circuit	Test Condition	min.	typ.	max.	Unit	
Supply Current	I_{CC}	1	No signal input	21 pin	21.0	27.0	34.5	mA
				9 pin	22.0	25.5	28.4	
Input Sensitivity	V_{in}	1	$V_{out}=1.35V_{p-p}$ (24 pin)	25	50	100	μV_{rms}	
AFC Output Voltage at No Signal Input	V_{16}	5	$V_{C(AFC)}=0$, $V_{15}=1V$	5.4	6.5	7.7	V	
			$V_{13-14}=80mV_{rms}$, $V_{15}=0$	—	4.5	—		
Signal-to-noise Ratio	S/N	2	$V_{in}=3mV_{rms}$ (no demodulation) $S/N=20 \log V_{out}/V_n$ (2 pin)	—	53	—	dB	
Max. Input Voltage	$V_{in\ max}$	1	$V_{13-14}=80mV_{rms}$, $DG=1dB$	—	12	—	mVrms	
Output Carrier-zero DC Voltage	V_W	1	$V_{in}=0$, $V_{22}=1.8V$	4.5	5.8	7.0	V	
Sync. Tip Voltage	V_P	1	$V_{in}=3mV_{rms}$, $m=75\%$	2 pin	3.9	4.1	4.3	V
				24 pin	7.35	7.7	8.05	
Differential Voltage between 14 and 13 pin	$V_{14, 13}$	1	Input volt. = $80\mu V_{rms}$ to $16mV_{rms}$ C.W. DC voltage between 14 and 13 pin. Measure $V_{14, 13}$.	-10	0	+10	mV	
Max. Video Output Voltage	V_{2M}	1	Voltage between 14 and 13 pin : $300mV_{rms}$ C.W. $V_{22}=1.8V$. Measure DC voltage at 2 pin.	—	—	2.5	V	
Video Frequency Response	f_B	1	V_{in} : modulation of video sweep, $3mV_{rms}$. Standardizing the output voltage at 100kHz. (2 pin)	2MHz	—	0	—	dB
				4MHz	—	0	—	
				6MHz	—	+1.5	—	
Supply Voltage for IF Block	V_9	1	$V_{CC}=12V$, $R_S=180\Omega$, DC voltage at 9 pin connecting V_{CC} through 180Ω .	$V_{in}=0$	6.4	7.4	7.9	V
				$V_{in}=3mV_{rms}$	5.8	6.4	7.0	
Small Signal Video Amp. Gain	A_{AC}	4	Input signal at 3 pin : 10kHz, 0.1 Vp-p plus 4.5V bias, Measure AC gain to 24 pin	-1.5	-0.7	0	dB	
Video Amp. DC Transfer Ratio	A_{DC}	4	Input voltage at 3 pin : 4V, DC voltage at 24 pin	7.25	7.6	7.95	V	
Video Amp. Bandwidth	B_V	4	Input signal at 3 pin : 0 to 20MHz. Sweep : 0.1 Vp-p+4.5V, Frequency when voltage at 24 pin goes down by 3dB	8	—	—	MHz	
Noise Canceller Threshold Voltage	V_{NS1}	4	Input signal wave from 1 is applied into 3 pin. V_{NS} means V_N at 3 pin when the pulse peak at 24 pin begins to rise up	0.3	0.5	0.7	V	
Noise Canceller Clamp Voltage	V_{NC}	4	Input signal wave forms 1 is applied into 3 pin. V_{NC} at output signal wave form 1 of 24 pin when $V_N=1V$.	0.45	0.7	0.95	V	
AFC Detector Sensitivity	μ_{AFC}	5	$f_o=58.75MHz$, $V_{in(AFC)}=14mV_{rms}$, $V_{CC}=12V$, $\Delta V=10V$ (1 to 11V)	—	—	200	$\frac{kHz}{10V}$	
AFC Output Voltage for Deviation of Input Frequency	V_{AFC}	5	$V_{CC}=12V$, $f_o=58.75MHz$, $V_{in(AFC)}=5mV_{rms}$	$f_o+2.0MHz$	2.0	—	—	V
				$f_o+1.5MHz$	1.0	—	—	
				$f_o+0.7MHz$	—	—	1.0	
				f_o+0MHz	—	6.0	—	
				$f_o-0.7MHz$	11.0	—	—	
				$f_o-1.5MHz$	—	—	11.0	
Noise Figure	F_I	3	Voltage at 12 pin is fixed. $V_{in}=3mV_{rms}$	C_{in}	—	6.0	—	dB
				R_{in}	—	—	—	
IF Input Impedance	Z_{in}	1	Either 6 or 7 pin grounded. 12 pin : 8.0V	C_{in}	30	40	50	pF
				R_{in}	70	100	140	Ω

■ TEST CIRCUITS

1.

- *1) S₁=1, Un ess. Specified.
- *2) S₂=3, Un ess. Specified.

*3. Constant of V_r:

$$V_r = \frac{1}{2\sqrt{m}} \times V_s \text{ mVrms}$$

Percentage of Modulation:

$$m = \frac{V_s - V_r}{V_s} \times 100 \%$$

Coil Specifications

Coil No.	Specifications
T ₁	6.5T
T ₂	3.5T
T ₃	Coil Diameter : 10φ Enamel Covered Wire 0.8 mm Dia. Q : Over 70

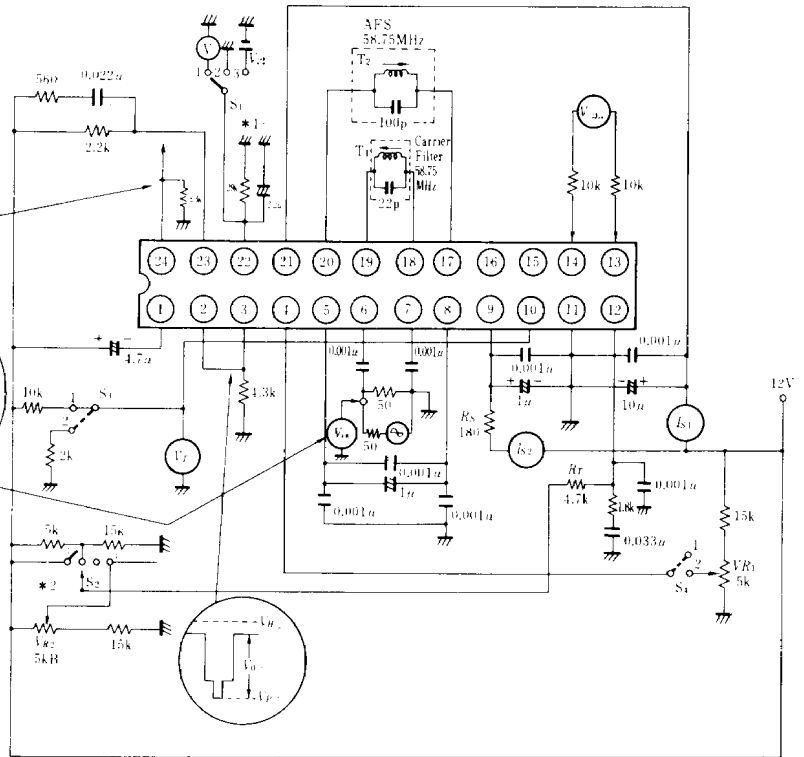

2.

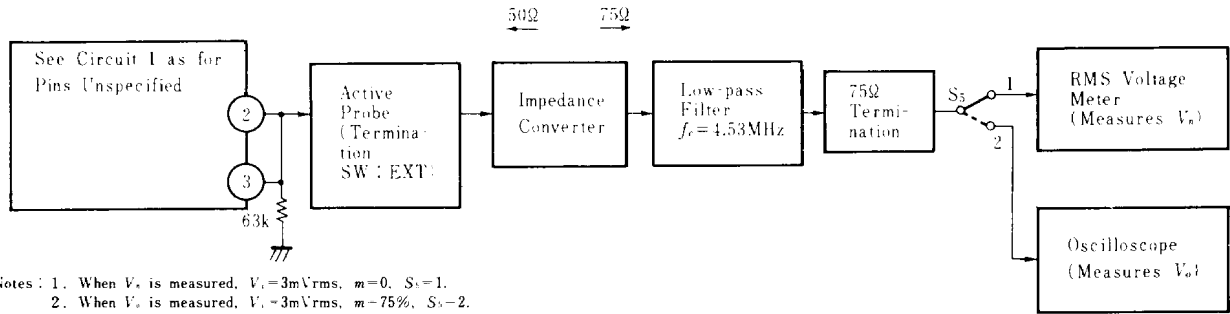

- Notes :
- When V_v is measured, V_s=3mVrms, m=0, S₁=1.
 - When V_r is measured, V_s=3mVrms, m=75%, S₁=2.
S/N=20log (V_v/V_r)

3.

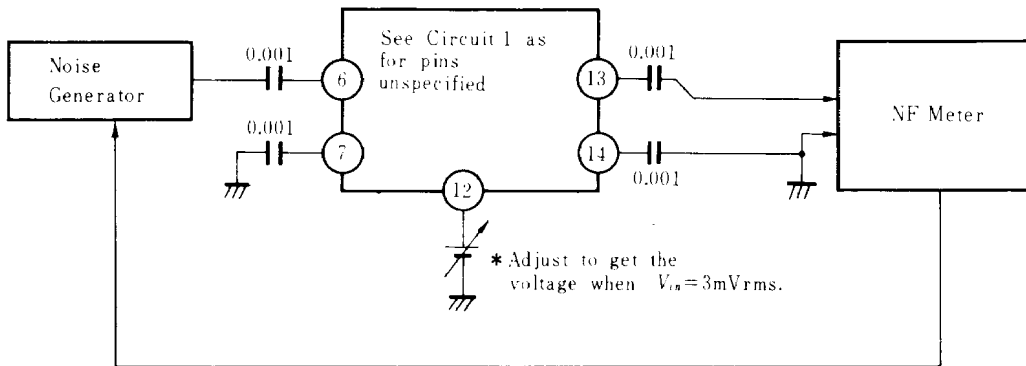

Unit C: F

4.

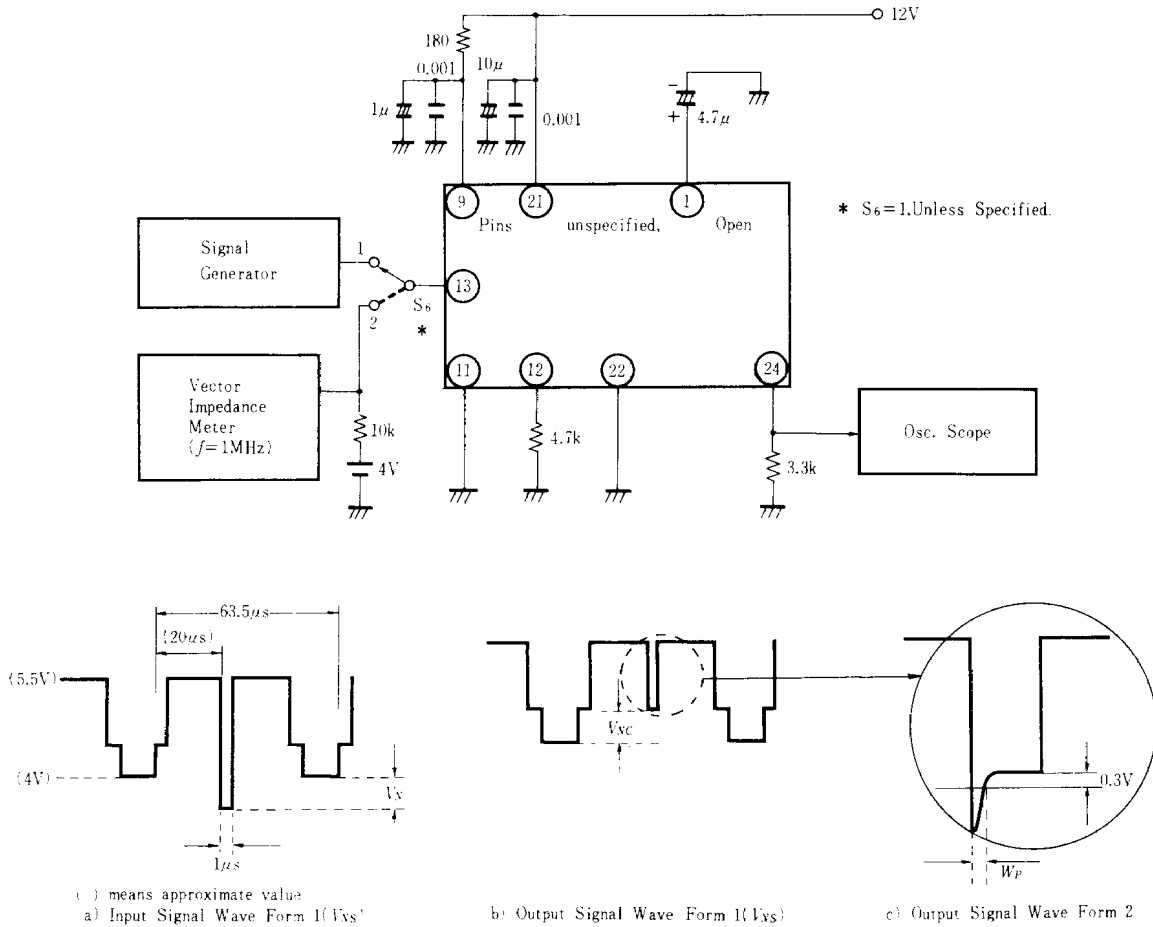

5.

