

February 1985

Features

- Central Office quality detection
- Excellent voice talk-off
- Detect times down to 20ms
- Single supply 5V or 8 to 13V operation
- Latched three-state buffered outputs
- Detects all 16 DTMF combinations
- Uses inexpensive 3.58 MHz crystal
- Low power CMOS circuitry
- Adjustable acquisition & release times

Applications

In DTMF Receivers For

- End to end signalling
- Control systems
- PABX
- Central Office
- Mobile Radio
- Key systems
- Tone to pulse converters

Description

The Mitel MT8860 detects and decodes all 16 DTMF tone pairs. The device accepts the high group and low group squarewave signals from a DTMF FILTER (Mitel MT8865) and provides a three-state buffered 4 Bit binary output. The clock signals are derived from an on-chip oscillator requiring only a single

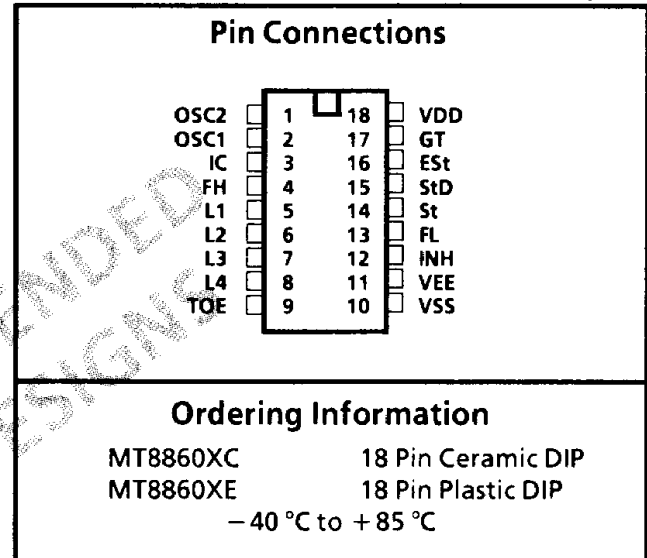

resistor and low cost TV crystal as external components. The MT8860 is implemented in CMOS technology and incorporates an on chip regulator, providing low power operation and power supply flexibility.

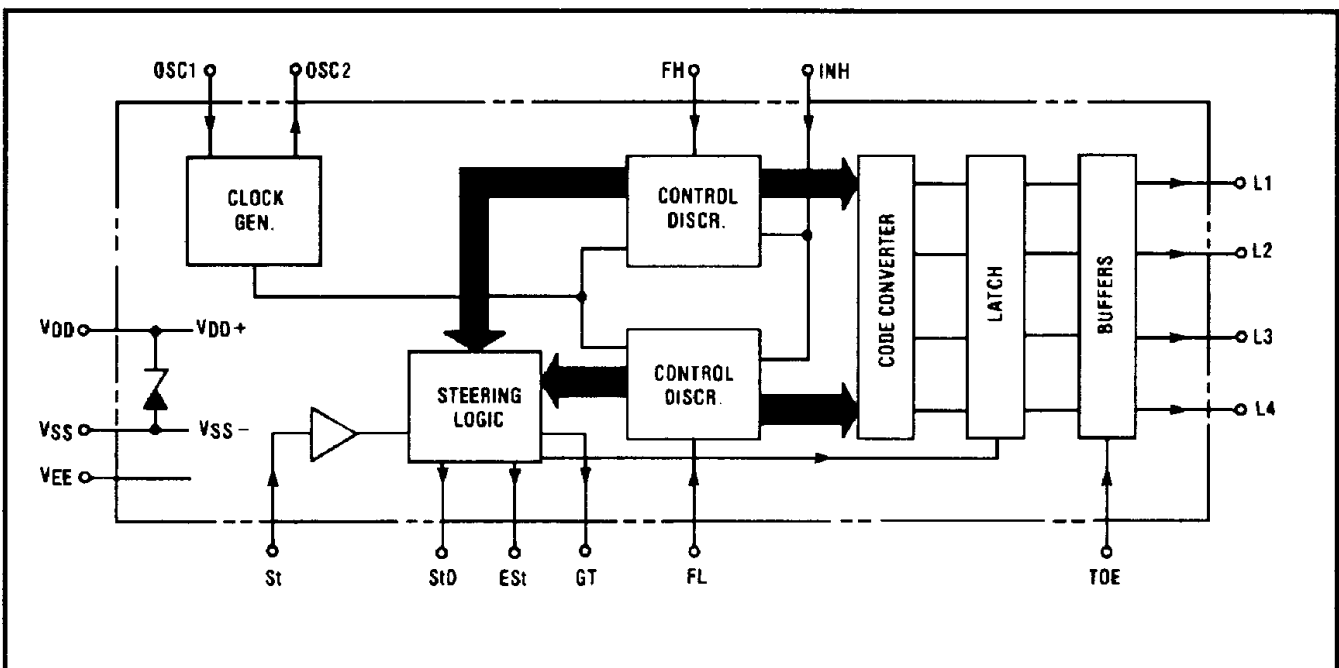
**Fig. 1 Functional Block Diagram**

Absolute Maximum Ratings*

	Parameter	Symbol	Min	Max	Units	
1	$V_{DD} - V_{EE}$			15	V	
2	$V_{DD} - V_{SS}$ (Low Impedance Supply)			5.5	V	
3	Voltage on any pin except OS1, OSC2		$V_{EE} - 0.3$	$V_{DD} + 0.3$	V	
4	Voltage on OSC1, OSC2		$V_{SS} - 0.3$	$V_{DD} + 0.3$	V	
5	Max. Current at any pin (except V_{DD} & V_{EE})	I_I		10	mA	
6	Storage Temperature	C Package	T_{STG}	-65	+150	°C
		E Package	T_{STG}	-65	+125	°C
7	Power Dissipation	C Package ^①	P_D		1000	mW
		E Package ^②	P_D		450	mW

*Exceeding these values may cause permanent damage. Functional operation under these conditions is not implied.

^①Derate above 75 °C at 16 mW / °C. All leads soldered to board.

^②Derate above 25 °C at 6.3 mW / °C. All leads soldered to board.

Recommended Operating Conditions - All voltages referenced to V_{EE} unless otherwise stated

	Parameter	Sym	Min	Typ [†]	Max	Units	Test Conditions
1	DC Power Supply Voltage ($V_{DD} - V_{EE}$)	V_{DD}	4.75	5	5.25	V	Connections, Fig. 5a
		V_{DD}	8		13	V	Connections, Fig. 5b
2	Operating Temperature	T_O	-45		+85	°C	

[†] Typical figures are at 25°C and are for design aid only: not guaranteed and not subject to production testing.

DC Electrical Characteristics - All voltages referenced to V_{EE} , $T_A = 25^\circ\text{C}$, $f_c = 3.579545$ MHz unless otherwise stated.

	Characteristics	Sym	Min	Typ [†]	Max	Units	Test Conditions
1	Operating Supply Voltage ($V_{DD} - V_{EE}$)	V_{DD}	4.75	5	5.25	V	Connections Fig. 5a
		V_{DD}	8		13	V	Connections Fig. 5b
2	Internal Logic Ground Voltage ($V_{DD} - V_{SS}$)	V_{DDSS}	4.75		5.25	V	Connections Fig. 5a
		V_{DDSS}	6.0	6.5	7.5	V	$I_{dd} = 7\text{mA}$
3	Operating Supply Current	I_{DD}		1.3	4	mA	5V
		I_{DD}		2.5	5	mA	12V $V_{DD} - V_{SS} = 5.5\text{V}$
4	Internal Logic Ground Pin Current	I_{SS}		5.5	6.7	mA	12V $R_{SSEE} = 900\Omega$
5	Operating Power Consumption	P_O		6.5		mW	5V
		P_O		66		mW	12V
6	High Level Input Voltage (All Inputs Except OSC1)	V_{IH}	3.5			V	5V
		V_{IH}	8.5			V	12V
7	Low Level Input Voltage (All Inputs Except OSC1)	V_{IL}			1.5	V	5V
		V_{IL}			3.5	V	12V
8	High Level Input Voltage OSC1	V_{IHO}	3.5			V	5V
		V_{IHO}	10.5			V	12V
9	Low Level Input Voltage OSC1	V_{ILO}			1.5	V	5V Ref V_{SS}
		V_{ILO}			1.5	V	12V Ref V_{SS}
10	Steering Input Threshold Voltage	V_{Tst}	2.04	2.27	2.5	V	5V
		V_{Tst}	5.4	6.0	6.6	V	12V
11	Pull Down Sink Current (INH)	I_{SI}	10	25	75	μA	5V
		I_{SI}	10	190	400	μA	12V
12	Pull Up Source Current (TOE)	I_{SO}	2	7	45	μA	5V + 12V
13	Input High Leakage Current	I_{IH}		0.1	1.5	μA	5V or 12V
14	Input Low Leakage Current	I_{LH}		0.1	1.5	μA	5V or 12V

[†] Typical figures are at 25°C and are for design aid only: not guaranteed and not subject to production testing.

DC Electrical Characteristics (cont'd)-All voltages referenced to V_{EE} , $T_A=25^{\circ}\text{C}$ $f_c=3.579545$ MHz unless otherwise stated.

	Characteristics	Sym	Min	Typ [†]	Max	Units	Test Conditions
15	High Level Output Voltage (All Outputs Except OSC2)	V_{OH}	4.9			V	5V
		V_{OH}	11.9			V	12V
16	Low Level Output Voltage (All Outputs Except OSC2)	V_{OL}			0.1	V	5V
		V_{OL}			0.1	V	12V
17	High Level Output Voltage OSC2	V_{OHO}	4.9			V	5V
		V_{OHO}	11.9			V	12V
18	Low Level Output Voltage OSC2	V_{OL}			0.1	V	5V Ref V_{SS}
		V_{OL}			0.1	V	12V Ref V_{SS}
19	Output Drive Current P Channel Source (All Outputs Except OSC2)	I_{OH}	0.4	0.6		mA	5V $V_{OH} = 4.6\text{V}$
		I_{OH}	0.5	0.8		mA	12V $V_{OH} = 11.5\text{V}$
20	Output Drive Current N Channel Sink (All Outputs Except OSC2)	I_{OL}	0.8	1.2		mA	5V $V_{OL} = 0.4\text{V}$
		I_{OL}	1.0	1.6		mA	12V $V_{OL} = 0.5\text{V}$
21	Output Drive Current - OSC2 P Channel Source	I_{OH}	90	120		μA	5V $V_{OH} = 4.6\text{V}$
		I_{OH}	90	120		μA	12V $V_{OH} = 11.5\text{V}$
22	Output Drive Current - OSC2 N Channel Sink	I_{OL}	100	160		μA	5V $V_{OL} = 0.4\text{V}$
		I_{OL}	100	160		μA	12V $V_{OL} = 0.5\text{V}$
23	Tristate Output Current (High Impedance State)	L1-L4 = H I_{OZ}		0.035	1.5	μA	5V Appl $V_{OL} = 0\text{V}$
		L1-L4 = L I_{OZ}		0.1	1.5	μA	5V Appl $V_{OH} = 5\text{V}$
		L1-L4 = H I_{OZ}		0.1	1.5	μA	12V Appl $V_{OL} = 0\text{V}$
		L1-L4 = L I_{OZ}		0.3	1.5	μA	12V Appl $V_{OH} = 12\text{V}$

[†] Typical figures are at 25°C and are for design aid only: not guaranteed and not subject to production testing.

Test Conditions: 5V: $V_{DD} - V_{EE} = 5\text{V}$ $V_{SS} = V_{EE}$ Connection as Fig. 5a, 12V: $V_{DD} - V_{EE} = 12\text{V}$ $R_{SSEE} = 900\Omega$ Connection as Fig. 5b

For Input current parameters only $V_{IH} = V_{IHO} = V_{DD}$, $V_{IL} = V_{IEE}$, $V_{ILO} = V_{SS}$

AC Electrical Characteristics - $V_{DD}=5\text{V}$, $T_A=25^{\circ}\text{C}$ $f_c=3.579545$ MHz unless otherwise stated.

	Characteristics	Sym	Min	Typ [†]	Max	Units	Test Conditions
1	Tone Freq. Deviation Accept	Δf_A			± 2.5	% Nom.	
2	Tone Freq. Deviation Reject	Δf_R	± 3.5			% Nom.	
3	Tone Present Detection Time (MT8860X)	t_{DP}	6		10	ms	
4	Tone Absent Detection Time (MT8860X)	t_{DA}	0.6		6	ms	
5	Guard Time (P or A)	t_{GT}	Adjustable Functions of t_{GT} - See Figs. 2,6,7.				
6	Time to Receive = ($t_{DP} + t_{GTP}$)	t_{REC}					
7	Invalid Tone Duration (f_n of t_{REC})	t_{REC}					
8	Interdigit Pause = ($t_{DA} + t_{GTA}$)	t_{ID}					
9	Acceptable Dropout (f_n of t_{ID})	t_{DO}					
10	FL FH Input Transition Time	t_T			1.0	μs	10% - 90% V_{DD}
11	Capacitance Any Input	C		5	7.5	pF	

[†] Typical figures are at 25°C and are for design aid only: not guaranteed and not subject to production testing.

3

AC Electrical Characteristics cont'd - $V_{DD}=5V$, $T_A=25^\circ C$, $f_c=3.579545$ MHz unless otherwise stated.

	Characteristics	Sym	Min	Typ [†]	Max	Units	Test Conditions		
12	O U T P U T S	Propagation Delay St to L ₁ -L ₄	t_{PL}	8	11	μs	V_{DD} 5V or 12V		
13		Propagation Delay St to StD	t_{PStD}	12	14	μs	V_{DD} 5V or 12V		
14		Sync. Delay L ₁ -L ₄ to StD	t_{LStD}	3.43		μs	V_{DD} 5V or 12V		
15	P	Propagation Delay TOE to L ₁ -L ₄ - Enable	t_{PTE}	300		ns	V_{DD} 5V		
			t_{PTE}	200		ns	V_{DD} 12V		
16	S	Propagation Delay TOE to L ₁ -L ₄ - Disable	t_{PTD}	300		ns	V_{DD} 5V		
			t_{PTD}	200		ns	V_{DD} 12V		
17	C L O C K	Crystal/Clock Frequency	f_c	3.5759	3.5795	3.581	MHz	OSC1 OSC2	
18		Clock Input (OSC 1)	Rise Time	t_{LHCl}		110	ns	10% - 90%	
			Fall Time	t_{HLCl}		110	ns	$V_{DD}-V_{SS}$	
19	K	Clock Output (OSC 2)	Duty Cycle	DC_{Cl}	40	50	60	%	Externally Applied Clock
			Clock Output Capacitive Load	C_{LO}			30	pF	

[†] Typical figures are at 25°C and are for design aid only: not guaranteed and not subject to production testing.

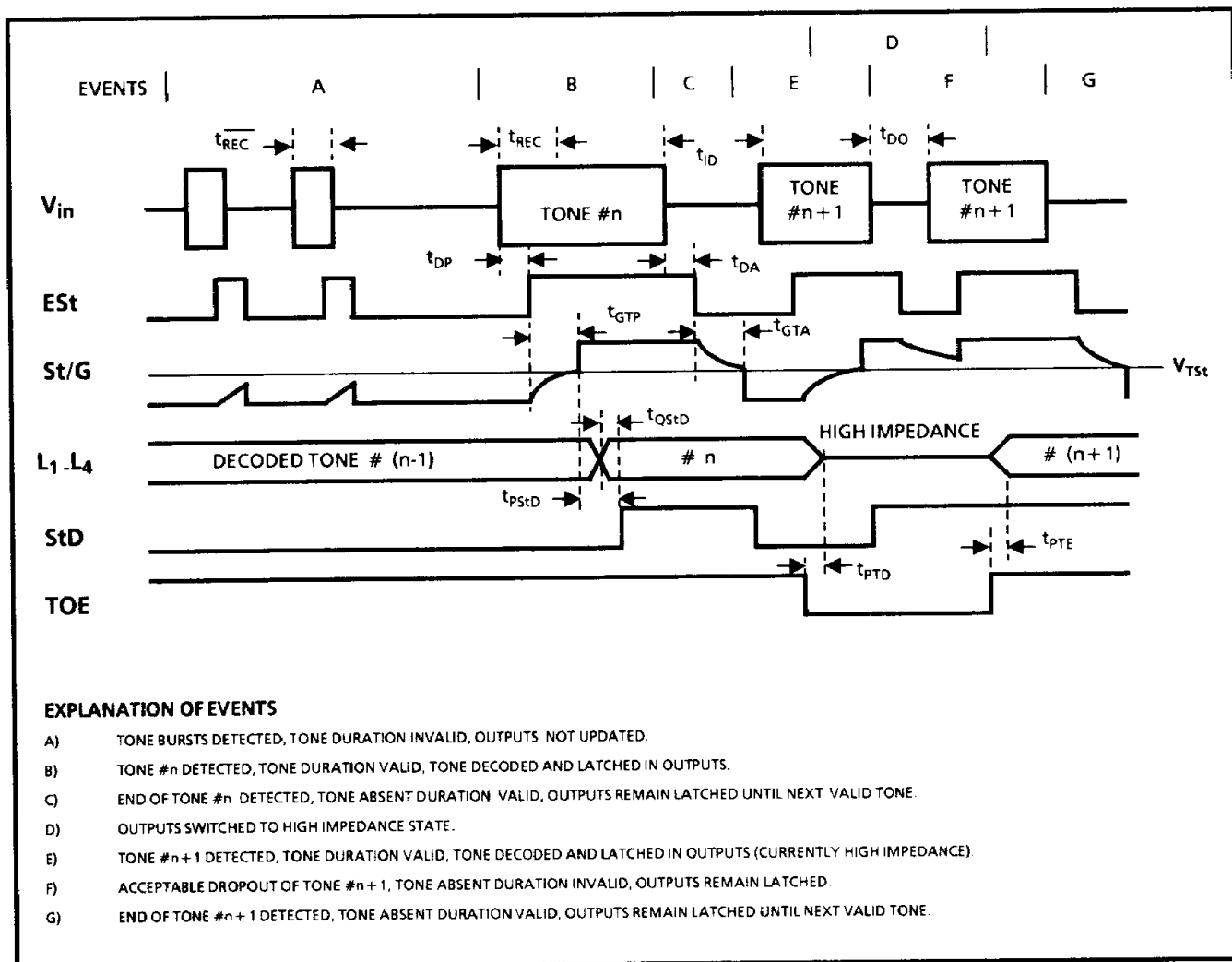

Figure 2- Timing Diagram

Original Tone Character		TOE	L4	L3	L2	L1	Detected Character	INH	ESt	ESt	St	GT	StD*
DR	X	L	Z	Z	Z	Z							
	1	H	L	L	L	H							
	2	H	L	L	H	L							
	3	H	L	L	H	H							
	4	H	L	H	L	L							
	5	H	L	H	L	H							
	6	H	L	H	H	L							
	7	H	L	H	H	H							
	8	H	H	L	L	L							
	9	H	H	L	L	H							
	0	H	H	L	H	L							
D	*	H	H	L	H	H	X	L	H	L	H	H	
	#	H	H	H	L	L							
	A	H	H	H	L	H							
	B	H	H	H	H	L							
	C	H	H	H	H	H							
D	H	L	L	L	L								

Fig. 3a) Output Coding

Detected Character	INH	ESt
None	0	L
X	L	H
DR	H	H
D	H	L

Fig. 3b) Inhibit Function

ESt	St	GT	StD*
L	L	L	L
H	L	Z	L
L	H	Z	H
H	H	H	H

Fig. 3c) Steering
*Delayed wrt St.

For the purpose of these Tables consider:

$V_{St} < V_{Tst}$ Logic LOW (L)

$V_{St} > V_{Tst}$ Logic HIGH (H)

H = LOGIC HIGH

L = LOGIC LOW

0 = "DON'T CARE" LOGIC HIGH OR LOW

Z = HIGH IMPEDANCE X = ANY CHARACTER

Fig. 3 - Coding Tables

Pin Description

Pin #	Name	Description
1	OSC2	Clock Output.
2	OSC1	Clock Input. 3.579545MHz crystal with parallel 5M resistor connected between this pin and OSC2 completes the internal oscillator, running between V_{DD} and V_{SS} .
3	IC	Internal Connection. For testing only. Must be left open circuit.
4	FH	High Frequency Group Input. Accepts single rectangular wave High group tone from DTMF filter.
5,6, 7,8	L1,L2, L3, L4	Data Outputs. Three-state buffered. Provides 4 Bit binary word corresponding to the tone pair decoded, when enabled by TOE. See Fig. 3 for state table.
9	TOE	Three-state Output Enable Input. Logic high on this input enables outputs L1-L4. Internal pull-up.
10	V_{SS}	Internal Logic Ground. For $V_{DD} - V_{EE} = 5V$ V_{SS} connected to V_{EE} . For $V_{DD} - V_{EE} > 8V$, V_{SS} connected via resistor to V_{EE} see Fig. 5.
11	V_{EE}	Negative Power Supply. External logic ground.
12	INH	Inhibit Input. Logic high inhibits detection of tones representing characters #, *, A, B, C, D. Internal pull-down.
13	FL	Low Frequency Group Input. Accepts single rectangular wave low group tone from DTMF filter.
14	St	Steering Input. A voltage greater than V_{Tst} on this input causes the device to accept validity of the detected tone pair and latch the corresponding codeword at the outputs. Voltage $< V_{Tst}$ on this pin frees the device to accept a new tone pair, see Fig. 3c and Functional Description.
15	StD	Delayed Steering Output. Flags when a valid tone pair has been received. Presents logic high when output latch updated. When St voltage exceeds V_{Tst} . Returns to logic low when St voltage falls below V_{Tst} .
16	ESt	Early Steering Output. Presents a logic high immediately the digital algorithm detects a recognizable tone pair. Any momentary loss of the incoming tone or excessive distortion of the tone will cause ESt to return to a logic low.
17	GT	Guard Time Output. Three-state output. Normally connected to St, is used in the steering algorithm and is a function of St and ESt (See Fig. 3c).
18	V_{DD}	Positive Power Supply.

Functional Description

The Mitel MT8860 is a CMOS Digital DTMF Detector and Decoder. Used in conjunction with a suitable DTMF filter (Mitel MT8865) it can detect and decode all 16 standard DTMF tone pairs, accurately discriminating between adjacent frequencies in both high and low groups in the presence of noise and normal voice signals.

To form a complete DTMF receiver the MT8860 must be preceded by a DTMF filter, the function of which is to separate the high group and low group components of the composite dual tone signal and limit the resulting pair of sine wave signals to produce rectangular wave signals having the same frequencies as the individual components of the composite DTMF input. The High Group and Low Group rectangular waves are applied to the MT8860's FH and FL inputs respectively. Mitel's MT8865 DTMF Filter provides these functions.

Within the MT8860 the FL and FH signals are operated on by a complex averaging algorithm. This is implemented using digital counting techniques (Control/Discriminators Fig. 1) to determine the frequencies of the incoming tones and verify that they correspond to standard DTMF frequencies. When both High Group and Low Group signals have been simultaneously detected a flag ESt (Logic High) is generated. ESt is generated (cancelled) rapidly on detecting the presence (absence) of a DTMF tone pair (see Fig. 2) and is used to perform a final validity check.

The final validity check requires the input DTMF signal to be present uninterrupted by drop out or excessive distortion (which would result in ESt being cancelled) for a minimum time (t_{REC}) before being considered valid. This contributes greatly to the talk-off performance of the system. The check also imposes a minimum period of "tone absent" before a valid received tone is recognized as having ended. This allows short periods of drop out (t_{DO}) or excessive noise to occur during a received tone, without it being misinterpreted as two successive characters by the steering circuit (ESt, St, GT). A capacitor C (Fig. 7a) is charged via resistor R from ESt when a DTMF tone pair is detected. After a period t_{GTP} V_C exceeds the St input threshold voltage V_{Tst} setting an internal flag indicating the detected signal is valid. Functioning of the check algorithm is completed by the three state output GT which is normally connected to St and operates under the control of ESt and St. Its mode of operation is shown by the steering state table (Fig. 3c) and timing diagram (Fig. 2).

Internally the presence of the ESt flag allows the control/discriminator to identify the detected tones to the code converter which in turn presents a 4 bit binary code word, corresponding to the original transmitted character, to the output latch. The appearance of the internal St flag clocks the latch, presenting the output code at the tristate outputs L_1 to L_4 . The St internal flag is delayed (by t_{pStD}) and appears at the StD output to provide a strobe output function indicating that a new character has been received and the output updated. StD will return to a logic low after the St flag has been reset by V_C (Fig. 7a) falling below V_{Tst} .

Increasing the "time to receive" t_{REC} tends to further improve "talk-off" performance (discrimination against voice simulation of a DTMF tone pair) but degrades the acceptable signal to noise ratio for the incoming signal. Increasing interdigit pause t_{ID} further reduces the probability of receiving the same character twice and improves acceptable signal-to-noise ratio but imposes a longer interdigit pause. Reducing t_{REC} or t_{ID} has the opposite effect respectively. The values of t_{REC} and t_{ID} can be tailored by adjusting t_{GTP} and t_{GTA} as shown in Fig. 7.

When $L_1 - L_4$ are connected to a data bus TOE may be controlled by external circuitry or connected directly to StD automatically enabling the outputs whenever a tone is received. In either case StD may be used to flag external circuitry indicating a character has been received.

The MT8860 may be operated from either a 5 volt or 8 to 13 volt supply by use of the internal zener reference. The relevant connection diagrams are shown in Fig. 5.

When using the MT8860 with the MT8865 DTMF Filter it is only necessary to use the MT8865 crystal oscillator (see Fig. 6). When using the higher supply voltage range the 8865 OSC2 output should be capacitively coupled to the 8860 OSC1 input as shown in Fig. 6.

Where it is desirable to receive only the DTMF digits taking INH to a logic high inhibits detection of the # * ABCD DTMF characters. This also further improves "talk-off" performance due to the reduced number of detectable tones.

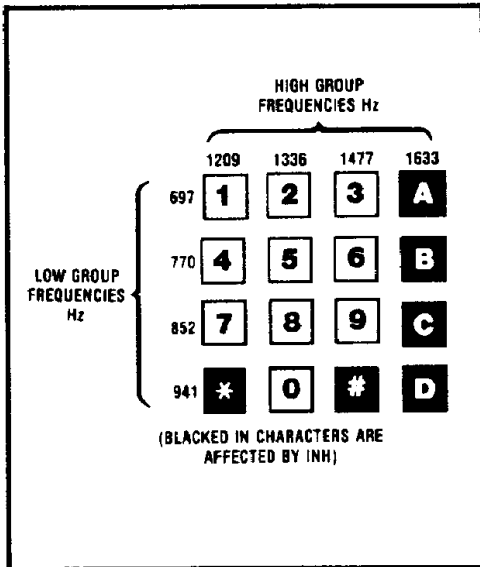

Fig. 4 - DTMF Matrix Indicating Character -Tone Pair Correspondence

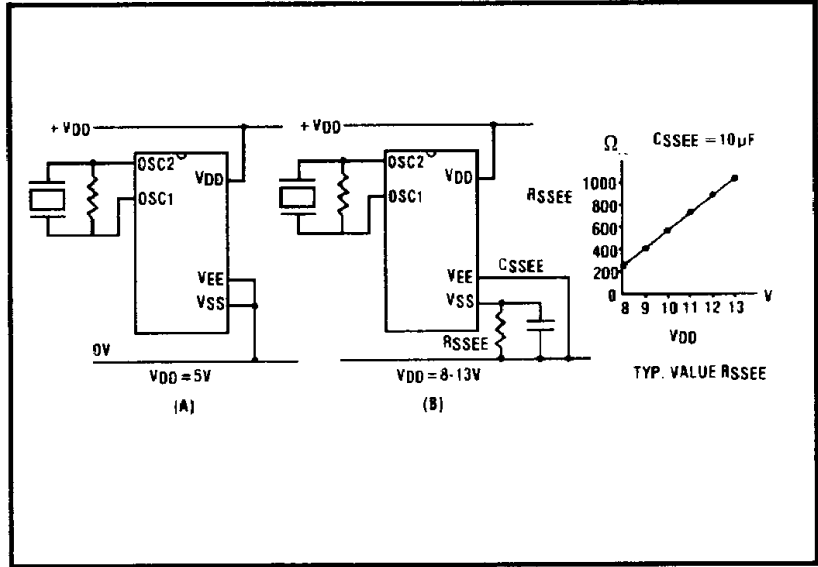

Fig. 5 - Power Supply Connection Options

3

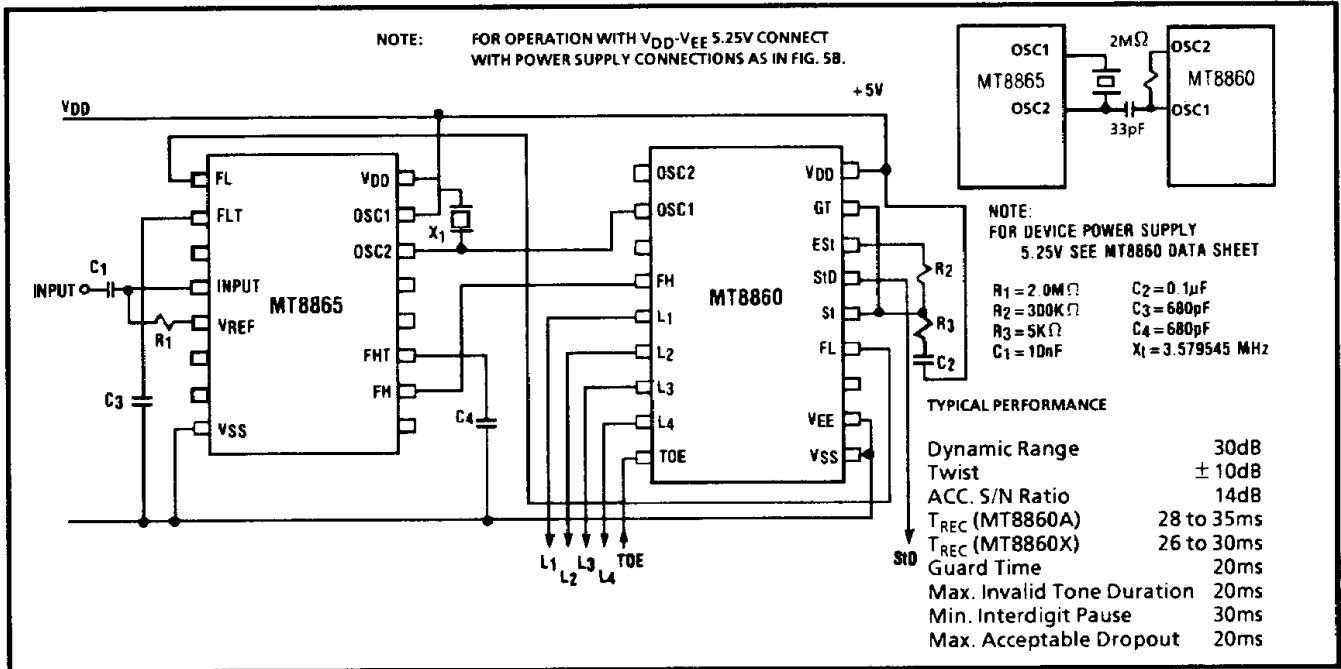

Fig. 6 - Connection Diagram for Single-Ended Input Receiver using the MT8865 (5V Operation)

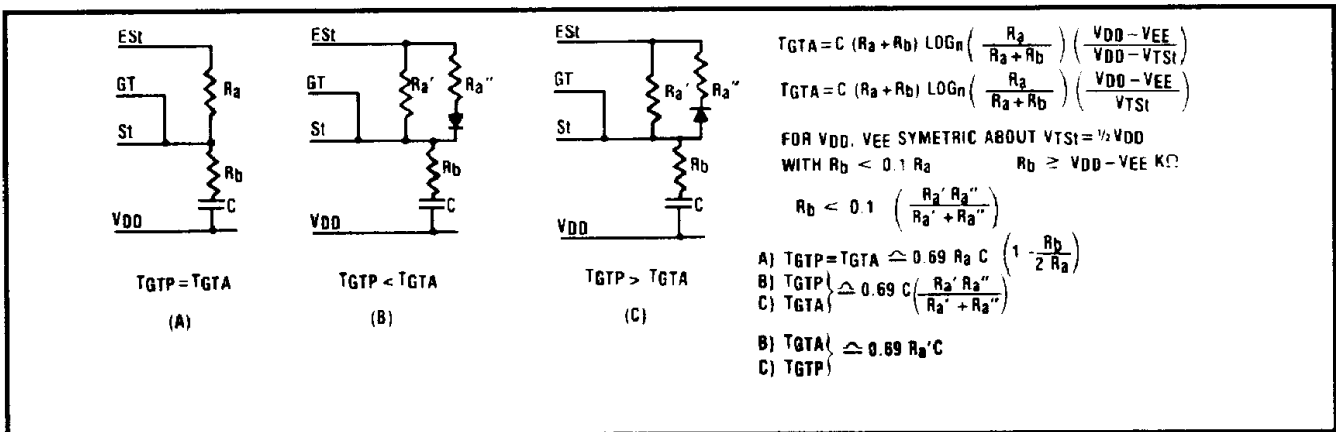

Fig. 7 - Guard Time Adjustment

Package Outlines

MITEL SEMICONDUCTOR

35E D ■ 6249370 0005778 6 ■ MITC

PACKAGING OUTLINES

T-90-20

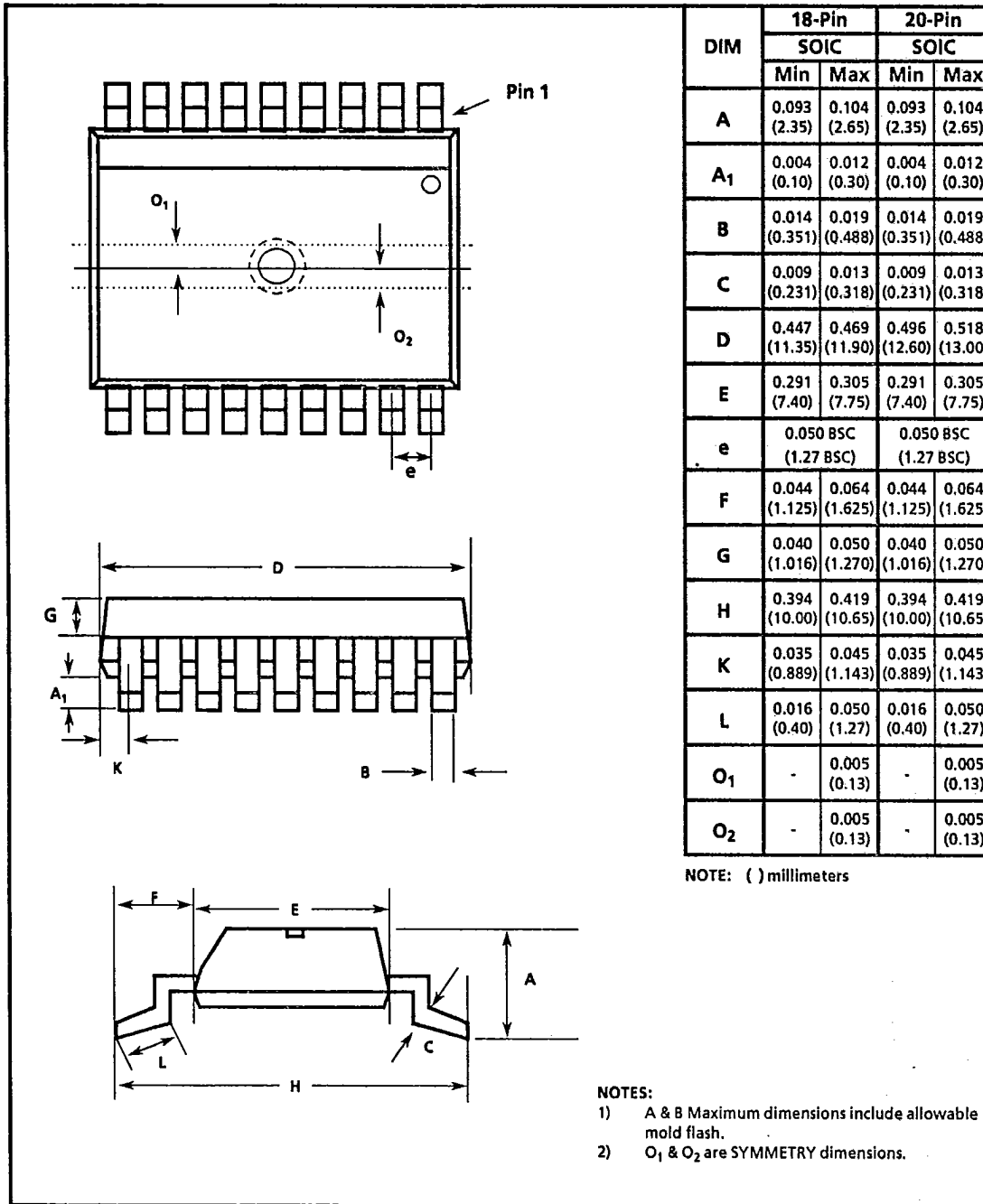

Lead SOIC Package (S Suffix)

Package Outlines

T-90-20

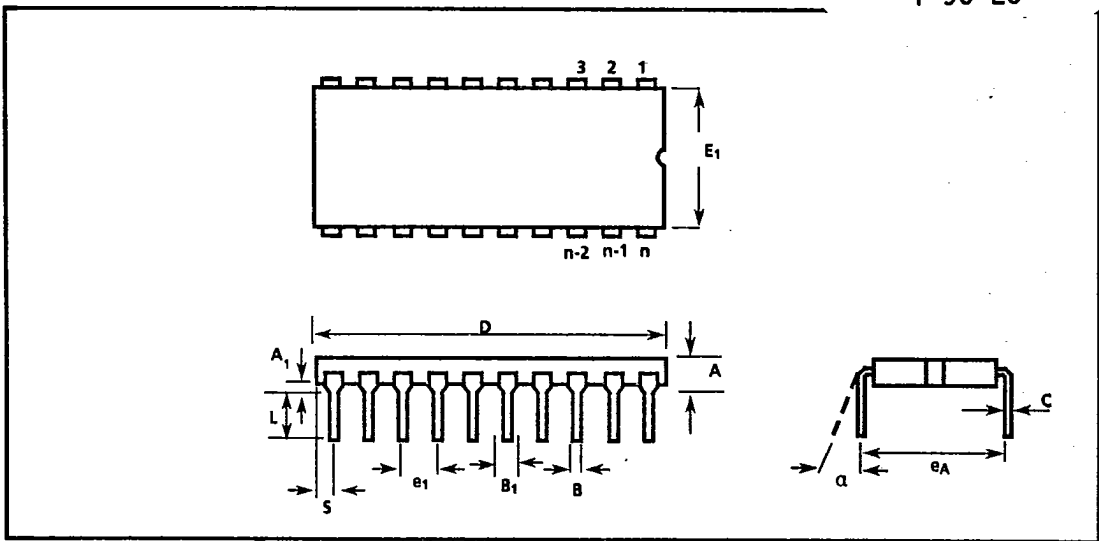

Ceramic Dual-In-Line Packages (CDIP) - C Suffix

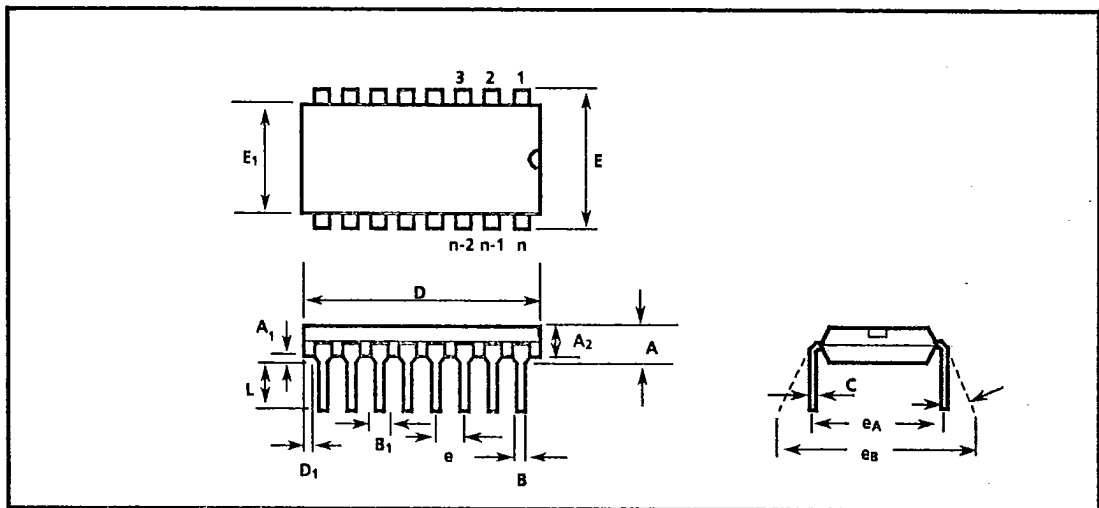

Plastic Dual-In-Line Packages (PDIP) - E Suffix

Package Outlines

T-90-20

DIM	8-Pin				16-Pin				18-Pin				20-Pin			
	Plastic		Ceramic		Plastic		Ceramic		Plastic		Ceramic		Plastic		Ceramic	
	Min	Max	Min	Max	Min	Max	Min	Max	Min	Max	Min	Max	Min	Max	Min	Max
A		0.210 (5.33)	0.105 (2.67)	0.200 (5.08)		0.210 (5.33)	0.105 (2.67)	0.200 (5.08)		0.210 (5.33)	0.105 (2.67)	0.200 (5.08)		0.210 (5.33)	0.105 (2.67)	0.200 (5.08)
A ₁			0.025 (0.64)	0.055 (1.39)			0.025 (0.64)	0.055 (1.39)			0.025 (0.64)	0.055 (1.39)			0.025 (0.64)	0.055 (1.39)
A ₂	0.115 (2.93)	0.195 (4.95)			0.115 (2.93)	0.195 (4.95)			0.115 (2.93)	0.195 (4.95)			0.115 (2.93)	0.195 (4.95)		
B	0.014 (0.356)	0.022 (0.558)	0.015 (0.381)	0.021 (0.533)	0.014 (0.356)	0.022 (0.558)	0.015 (0.381)	0.021 (0.533)	0.014 (0.356)	0.022 (0.558)	0.015 (0.381)	0.021 (0.533)	0.014 (0.356)	0.022 (0.558)	0.015 (0.381)	0.021 (0.533)
B ₁	0.045 (1.15)	0.070 (1.77)	0.035 (0.89)	0.060 (1.52)	0.045 (1.15)	0.070 (1.77)	0.035 (0.89)	0.060 (1.52)	0.045 (1.15)	0.070 (1.77)	0.035 (0.89)	0.060 (1.52)	0.045 (1.15)	0.070 (1.77)	0.035 (0.89)	0.060 (1.52)
C	0.008 (0.204)	0.015 (0.381)	0.008 (0.204)	0.012 (0.304)	0.008 (0.204)	0.015 (0.381)	0.008 (0.204)	0.012 (0.304)	0.008 (0.204)	0.015 (0.381)	0.008 (0.204)	0.012 (0.304)	0.008 (0.204)	0.015 (0.381)	0.008 (0.204)	0.012 (0.304)
D	0.348 (8.84)	0.430 (10.92)	0.380 (9.7)	0.550 (13.9)	0.745 (18.93)	0.840 (21.33)		0.784 (19.9)	0.845 (21.47)	0.925 (23.49)	0.880 (22.36)	0.930 (23.62)	0.925 (23.49)	1.060 (26.9)		0.996 (25.3)
D ₁	0.005 (0.13)				0.005 (0.13)				0.005 (0.13)					0.005 (0.13)		
E	0.290 (7.37)	0.330 (8.38)			0.290 (7.37)	0.330 (8.38)			0.290 (7.37)	0.330 (8.38)			0.290 (7.37)	0.330 (8.38)		
E ₁	0.240 (6.10)	0.280 (7.11)	0.280 (7.12)	0.310 (7.87)	0.240 (6.10)	0.280 (7.11)	0.280 (7.12)	0.310 (7.87)	0.240 (6.10)	0.280 (7.11)	0.280 (7.12)	0.310 (7.87)	0.240 (6.10)	0.280 (7.11)	0.280 (7.12)	0.310 (7.87)
e	0.100 BSC (2.54 BSC)				0.100 BSC (2.54 BSC)				0.100 BSC (2.54 BSC)				0.100 BSC (2.54 BSC)			
e ₁			0.100 BSC (2.54 BSC)				0.100 BSC (2.54 BSC)				0.100 BSC (2.54 BSC)				0.100 BSC (2.54 BSC)	
eA	0.300 BSC (7.62 BSC)		0.300 BSC (7.62 BSC)		0.300 BSC (7.62 BSC)		0.300 BSC (7.62 BSC)		0.300 BSC (7.62 BSC)		0.300 BSC (7.62 BSC)		0.300 BSC (7.62 BSC)		0.300 BSC (7.62 BSC)	
eB		0.430 (10.92)				0.430 (10.92)				0.430 (10.92)				0.430 (10.92)		
L	0.115 (2.93)	0.160 (4.06)	0.125 (3.18)	0.175 (4.44)	0.115 (2.93)	0.160 (4.06)	0.125 (3.18)	0.175 (4.44)	0.115 (2.93)	0.160 (4.06)	0.125 (3.18)	0.175 (4.44)	0.115 (2.93)	0.160 (4.06)	0.125 (3.18)	0.175 (4.44)
S				0.120 (3.04)				0.120 (3.04)				0.120 (3.04)				0.120 (3.04)
α			0°	15°			0°	15°			0°	15°			0°	15°

NOTE: () Millimeters

Package Outlines

T-90-20

DIM	22-Pin				24-Pin				28-Pin				40-Pin			
	Plastic		Ceramic		Plastic		Ceramic		Plastic		Ceramic		Plastic		Ceramic	
	Min	Max	Min	Max	Min	Max	Min	Max	Min	Max	Min	Max	Min	Max	Min	Max
A		0.210 (5.33)	0.090 (2.29)	0.225 (5.71)		0.250 (6.35)	0.085 (2.2)	0.190 (4.8)		0.250 (6.35)	0.085 (2.2)	0.190 (4.8)		0.250 (6.35)	0.085 (2.2)	0.190 (4.8)
A ₁			0.025 (0.64)	0.055 (1.39)			0.020 (0.51)	0.070 (1.77)			0.020 (0.51)	0.070 (1.77)			0.020 (0.51)	0.070 (1.77)
A ₂	0.125 (3.18)	0.195 (4.95)			0.125 (3.18)	0.195 (4.95)			0.125 (3.18)	0.195 (4.95)			0.125 (3.18)	0.195 (4.95)		
B	0.014 (0.356)	0.022 (0.558)	0.015 (0.381)	0.023 (0.584)	0.014 (0.356)	0.022 (0.558)	0.015 (0.381)	0.023 (0.584)	0.014 (0.356)	0.022 (0.558)	0.015 (0.381)	0.023 (0.584)	0.014 (0.356)	0.022 (0.558)	0.015 (0.381)	0.023 (0.584)
B ₁	0.045 (1.15)	0.070 (1.77)	0.028 (0.71)	0.060 (1.52)	0.030 (0.77)	0.070 (1.77)	0.028 (0.71)	0.060 (1.52)	0.030 (0.77)	0.070 (1.77)	0.028 (0.71)	0.060 (1.52)	0.030 (0.77)	0.070 (1.77)	0.028 (0.71)	0.060 (1.52)
C	0.008 (0.204)	0.015 (0.381)	0.008 (0.204)	0.012 (0.304)	0.008 (0.204)	0.015 (0.381)	0.008 (0.204)	0.012 (0.304)	0.008 (0.204)	0.015 (0.381)	0.008 (0.204)	0.012 (0.304)	0.008 (0.204)	0.015 (0.381)	0.008 (0.204)	0.012 (0.304)
D	1.050 (26.67)	1.120 (28.44)	1.040 (26.42)	1.260 (32.0)	1.150 (29.3)	1.290 (32.7)	1.180 (29.88)	1.291 (32.80)	1.380 (35.1)	1.565 (39.7)	1.380 (35.06)	1.520 (38.61)	1.980 (50.3)	2.095 (53.2)	1.980 (50.30)	2.110 (53.60)
D ₁	0.005 (0.13)				0.005 (0.13)				0.005 (0.13)				0.005 (0.13)			
E	0.390 (9.91)	0.430 (10.92)			0.600 (15.24)	0.670 (17.02)			0.600 (15.24)	0.670 (17.02)			0.600 (15.24)	0.670 (17.02)		
E ₁	0.330 (8.39)	0.380 (9.65)	0.350 (8.89)	0.410 (10.41)	0.485 (12.32)	0.580 (14.73)	0.516 (13.11)	0.610 (15.49)	0.485 (12.32)	0.580 (14.73)	0.480 (12.19)	0.610 (15.49)	0.485 (12.32)	0.580 (14.73)	0.480 (12.19)	0.618 (15.70)
e	0.100 BSC (2.54 BSC)				0.100 BSC (2.54 BSC)				0.100 BSC (2.54 BSC)				0.100 BSC (2.54 BSC)			
e ₁			0.100 BSC (2.54 BSC)				0.100 BSC (2.54 BSC)				0.100 BSC (2.54 BSC)				0.100 BSC (2.54 BSC)	
eA	0.400 BSC (10.16 BSC)		0.400 BSC (10.16 BSC)		0.600 BSC (15.24 BSC)		0.600 BSC (15.24 BSC)		0.600 BSC (15.24 BSC)		0.600 BSC (15.24 BSC)		0.600 BSC (15.24 BSC)		0.600 BSC (15.24 BSC)	
eB		0.500 (12.70)				0.700 (17.78)				0.700 (17.78)				0.700 (17.78)		
L	0.115 (2.93)	0.160 (4.06)	0.125 (3.18)	0.175 (4.44)	0.115 (2.93)	0.200 (5.08)	0.125 (3.18)	0.175 (4.44)	0.115 (2.93)	0.200 (5.08)	0.125 (3.18)	0.175 (4.44)	0.115 (2.93)	0.200 (5.08)	0.125 (3.18)	0.175 (4.44)
S				0.120 (3.04)				0.100 (2.54)				0.800 (2.05)				0.800 (2.05)
α			0°	15°			0°	15°			0°	15°			0°	15°

NOTE: () Millimeters

Package Outlines

T-90-20

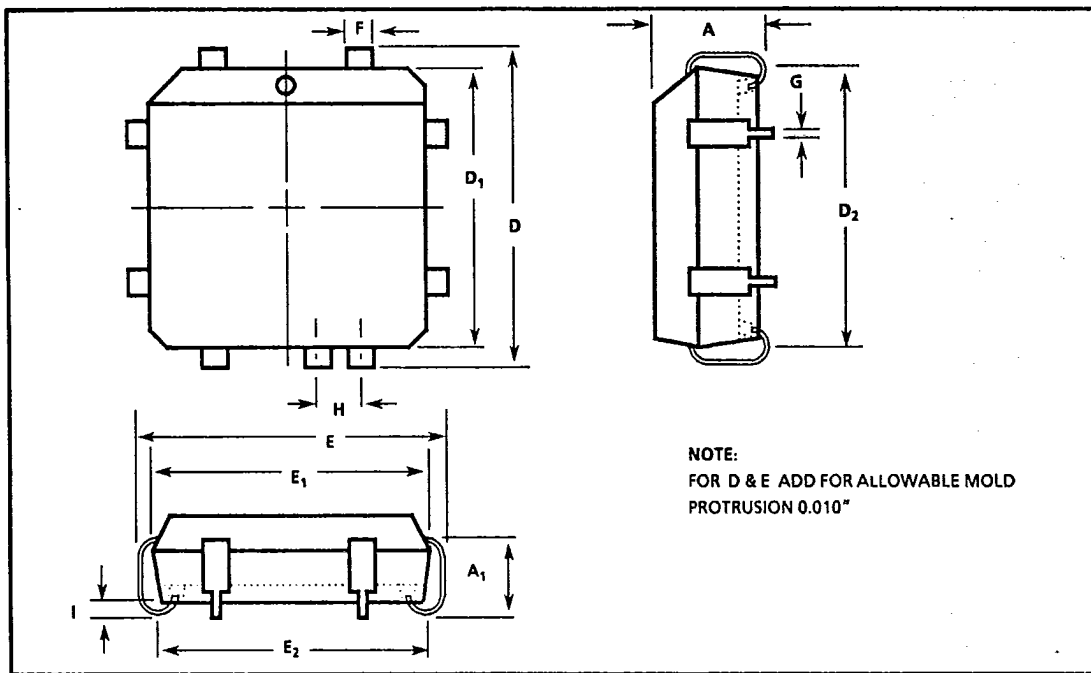

NOTE:
FOR D & E ADD FOR ALLOWABLE MOLD
PROTRUSION 0.010"

Plastic J-Lead Chip Carrier (P-Suffix)

Package Outlines

MITEL SEMICONDUCTOR

35E D 6249370 0005783 T MITC

T-90-20



DIM	20-Pin		28-Pin		44-Pin		68-Pin		84-Pin	
	PLCC		PLCC		PLCC		PLCC		PLCC	
	Min	Max	Min	Max	Min	Max	Min	Max	Min	Max
A	0.165 (4.20)	0.180 (4.57)	0.165 (4.20)	0.180 (4.57)	0.165 (4.20)	0.180 (4.57)	0.165 (4.20)	0.200 (5.08)	0.165 (4.20)	0.200 (5.08)
A ₁	0.090 (2.29)	0.120 (3.04)	0.090 (2.29)	0.120 (3.04)	0.090 (2.29)	0.120 (3.04)	0.090 (2.29)	0.130 (3.30)	0.090 (2.29)	0.130 (3.30)
B			0.020 TP (0.511 TP)							
B ₁										
B ₂										
D/E	0.385 (9.78)	0.395 (10.03)	0.485 (12.32)	0.495 (12.57)	0.685 (17.40)	0.695 (17.65)	0.985 (25.02)	0.995 (25.27)	0.185 (30.10)	1.195 (30.35)
D ₁ /E ₁	0.350 (8.890)	0.356 (9.042)	0.450 (11.430)	0.456 (11.582)	0.650 (16.510)	0.656 (16.662)	0.950 (24.130)	0.958 (24.333)	1.150 (29.210)	1.158 (29.413)
D ₂ /E ₂	0.290 (7.37)	0.330 (8.38)	0.390 (9.91)	0.430 (10.92)	0.590 (14.99)	0.630 (16.00)	0.890 (22.61)	0.930 (23.62)	1.090 (27.69)	1.130 (28.70)
D ₄ /E ₄										
e			0.050 BSC (1.27 BSC)							
F	0.026 (0.661)	0.032 (0.812)	0.026 (0.661)	0.032 (0.812)	0.026 (0.661)	0.032 (0.812)	0.026 (0.661)	0.032 (0.812)	0.026 (0.661)	0.032 (0.812)
G	0.013 (0.331)	0.021 (0.533)	0.013 (0.331)	0.021 (0.533)	0.013 (0.331)	0.021 (0.533)	0.013 (0.331)	0.021 (0.533)	0.013 (0.331)	0.021 (0.533)
H	0.050 BSC (1.27 BSC)				0.050 BSC (1.27 BSC)		0.050 BSC (1.27 BSC)		0.050 BSC (1.27 BSC)	
h			0.040 BSC (1.02 BSC)							
h ₁										
i	0.020 (0.51)		0.020 (0.51)		0.020 (0.51)		0.020 (0.51)		0.020 (0.51)	
L										
L ₁										
R ₁										

NOTE: () Millimeters