

FEATURES

- 8V to 35V Operation
- *Guaranteed* $\pm 1\%$ 5V Reference
- *Guaranteed* 10mV/1000 Hrs. Long Term Stability
- *Guaranteed* $\pm 3\%$ Oscillator Temperature Stability
- Undervoltage Lockout
- 100mA Source/Sink Outputs

APPLICATIONS

- Switching Power Supplies
- Motor Speed Control
- Power Converters

DESCRIPTION

The LT1526 is an improved general purpose switching regulator control circuit. Included on the chip are a 1% voltage reference, oscillator, error amplifier, pulse width modulator and low impedance output drivers. Also included are protective features such as a current limit comparator, undervoltage lockout, soft-start circuitry, and adjustable deadtime. This versatile device can be used to implement single-ended or push-pull switching regulators of either polarity, both transformerless and transformer-coupled.

Although pin-for-pin and functionally compatible with industry standard 1526 and 3526 devices, Linear Technology has incorporated several improvements in the design of the LT1526. A subsurface zener has been used to provide excellent reference voltage stability and the reference offers improved line regulation and load regulation. The current limit comparator sense voltage initial accuracy and temperature stability have been greatly improved.

The combination of improved features and advanced linear processing for high reliability make Linear Technology's switching regulators a superior choice.

BLOCK DIAGRAM

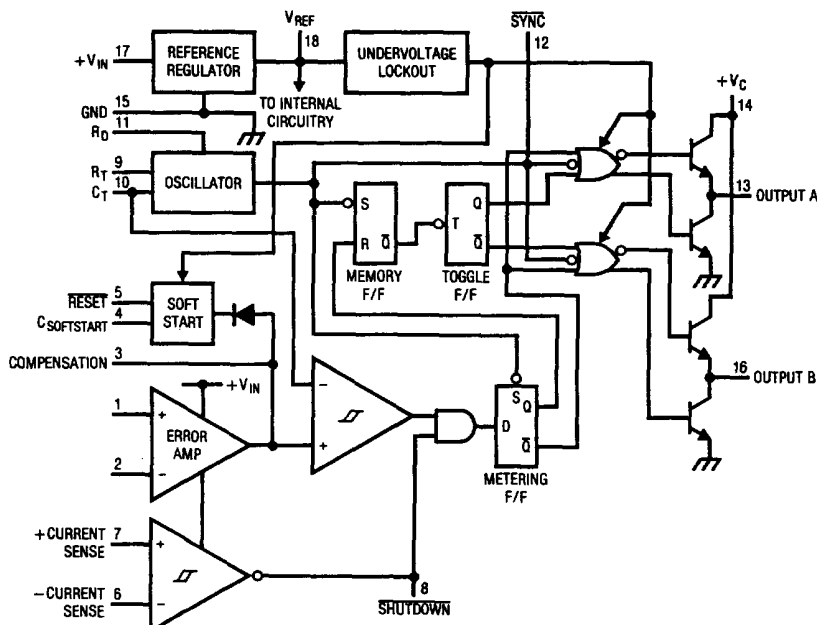

Reference Line Regulation

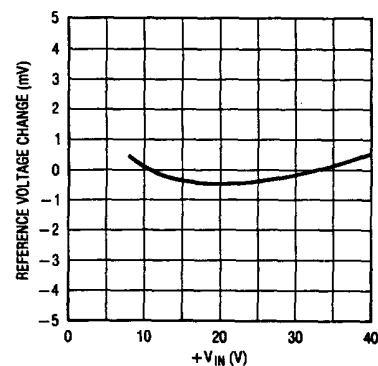

ABSOLUTE MAXIMUM RATINGS

(Note 1)

Input Voltage (+ V _{IN})	+ 40V
Collector Supply Voltage (+ V _C)	+ 40V
Logic Inputs	- 0.3V to + 5.5V
Analog Inputs	- 0.3V to + V _{IN}
Source/Sink Load Current (each output)	200mA
Reference Load Current	50mA
Logic Sink Current	15mA
Operating Junction Temperature Range	
LT1526	- 55°C to + 150°C
LT3526	0°C to + 125°C
Storage Temperature Range	- 65°C to + 150°C
Lead Temperature (Soldering, 10sec)	+ 300°C

PACKAGE/ORDER INFORMATION

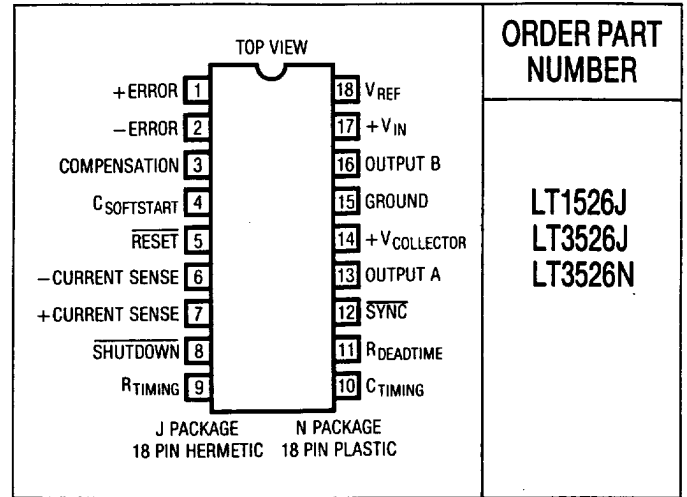

RECOMMENDED OPERATING CONDITIONS (Note 2)

Input Voltage	+ 8V to + 35V	Oscillator Frequency Range	1Hz to 400kHz
Collector Supply Voltage	+ 4.5V to + 35V	Oscillator Timing Resistor	2kΩ to 150kΩ
Sink/Source Load Current (each output)	0mA to 100mA	Oscillator Timing Capacitor	1nF to 20μF
Reference Load Current	- 5mA to 20mA	Available Deadtime Range at 40kHz	3% to 50%

ELECTRICAL CHARACTERISTICS

(+ V_{IN} = 15V, and over operating junction temperature, unless otherwise specified.)

PARAMETER	CONDITIONS	LT1526			LT3526			UNITS	
		MIN	TYP	MAX	MIN	TYP	MAX		
REFERENCE SECTION (Note 3)									
Output Voltage	T _J = + 25°C	4.95	5.00	5.05	4.90	5.00	5.10	V	
Line Regulation	+ V _{IN} = 8V to 35V	●	2	10	●	2	15	mV	
Load Regulation	I _L = - 5mA to + 20mA	●	5	10	●	5	20	mV	
Temperature Stability		●	15	50	●	15	50	mV	
Total Output Voltage Range	Over Recommended Operating Conditions	●	4.90	5.00	5.10	4.85	5.00	5.15	V
Short Circuit Current	V _{REF} = 0V	●	25	50	100	25	50	100	mA
Long Term Stability	T _J = 125°C	●	2	10	●	2	10	mV/√khr	
UNDERVOLTAGE LOCKOUT									
RESET Output Voltage	V _{REF} = 3.8V	●	0.2	0.4	●	0.2	0.4	V	
RESET Output Voltage	V _{REF} = 4.8V	●	2.4	4.8	●	2.4	4.8	V	
OSCILLATOR SECTION (Note 4)									
Initial Accuracy	T _J = + 25°C	●	± 3	± 8	●	± 3	± 8	%	
Voltage Stability	+ V _{IN} = 8V to 35V	●	0.5	1	●	0.5	1	%	
Temperature Stability		●	1	3	●	1	3	%	

ELECTRICAL CHARACTERISTICS

(+V_{IN} = 15V, and over operating junction temperature, unless otherwise specified.)

PARAMETER	CONDITIONS		LT1526			LT3526			UNITS
			MIN	TYP	MAX	MIN	TYP	MAX	
OSCILLATOR SECTION (Note 4)									
Minimum Frequency	R _T = 150kΩ, C _T = 20μF	●			1			1	Hz
Maximum Frequency	R _T = 2kΩ, C _T = 1.0nF	●		400			400		kHz
Sawtooth Peak Voltage	+V _{IN} = 35V	●		3.0	3.5		3.0	3.5	V
Sawtooth Valley Voltage	+V _{IN} = 8V	●	0.5	1.0		0.5	1.0		V
ERROR AMPLIFIER SECTION (Note 5)									
Input Offset Voltage	R _S ≤ 2kΩ	●		2	5		2	10	mV
Input Bias Current		●		-350	-1000		-350	-2000	nA
Input Offset Current		●		35	100		35	200	nA
DC Open Loop Gain	R _L ≥ 10MΩ	●	64	72		60	72		dB
High Output Voltage	V _{pin1} - V _{pin2} ≥ 150mV, I _{source} = 100μA	●	3.6	4.2		3.6	4.2		V
Low Output Voltage	V _{pin2} - V _{pin1} ≥ 150mV, I _{sink} = 100μA	●		0.2	0.4		0.2	0.4	V
Common-Mode Rejection	R _S ≤ 2kΩ	●	70	94		70	94		dB
Supply Voltage Rejection	+V _{IN} = 12V to 18V	●	66	80		66	80		dB
PWM COMPARATOR (Note 4)									
Minimum Duty Cycle	V _{compensation} = +0.4V	●			0			0	%
Maximum Duty Cycle	V _{compensation} = +3.6V	●	45	49		45	49		%
DIGITAL PORTS (SYNC, SHUTDOWN, and RESET)									
HIGH Output Voltage	I _{source} = 40μA	●	2.4	4.0		2.4	4.0		V
LOW Output Voltage	I _{sink} = 3.6mA	●		0.2	0.4		0.2	0.4	V
HIGH Input Current	V _{IH} = +2.4V	●		-125	-200		-125	-200	μA
LOW Input Current	V _{IL} = +0.4V	●		-225	-360		-225	-360	μA
CURRENT LIMIT COMPARATOR (Note 6)									
Sense Voltage	R _S ≤ 50Ω	●	90	100	110	80	100	120	mV
Input Bias Current		●		-3	-10		-3	-10	μA
SOFT-START SECTION									
Error Clamp Voltage	RESET = +0.4V	●		0.1	0.4		0.1	0.4	V
C _S Charging Current	RESET = +2.4V	●	50	100	150	50	100	150	μA
OUTPUT DRIVERS (Each Output) (Note 7)									
HIGH Output Voltage	I _{source} = 20mA	●	12.5	13.5		12.5	13.5		V
	I _{source} = 100mA	●	12	13		12	13		V
LOW Output Voltage	I _{sink} = 20mA	●		0.2	0.3		0.2	0.3	V
	I _{sink} = 100mA	●		1.2	2.0		1.2	2.0	V
Collector Leakage	V _C = 40V	●		50	150		50	150	μA
Rise Time	C _L = 1000pF	●		0.3	0.6		0.3	0.6	μs
Fall Time	C _L = 1000pF	●		0.1	0.2		0.1	0.2	μs
POWER CONSUMPTION (Note 8)									
Standby Current	SHUTDOWN = +0.4V	●		18	30		18	30	mA

The ● denotes specifications that apply over the full operating temperature range.

The shaded electrical specifications indicate those parameters which have been improved or guaranteed test limits provided for the first time.

Note 1: Values beyond which damage may occur.

Note 2: Range over which the device is functional and parameter limits are guaranteed.

Note 3: I_L = 0mA.

Note 4: f_{OSC} = 40kHz (R_T = 4.12kΩ ± 1%, C_T = 0.01μF ± 1%, R_D = 0Ω).

Note 5: V_{CM} = 0V to +5.2V.

Note 6: V_{CM} = 0 to V_{IN} - 3V. The current limit sense voltage for the LT1526 is 80mV ≤ V_{SENSE} ≤ 120mV for temperatures less than 0°C or greater than 125°C.

Note 7: V_C = +15V.

Note 8: +V_{IN} = +35V, R_T = 4.12kΩ.

TYPICAL PERFORMANCE CHARACTERISTICS

Reference Voltage vs Supply Voltage

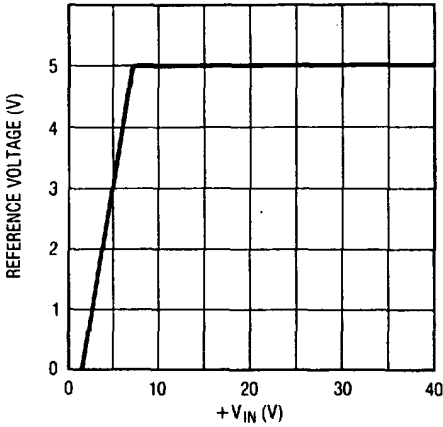

Reference Temperature Stability

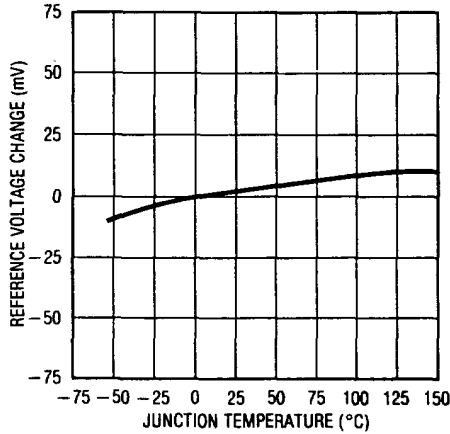

Reference Short Circuit Current

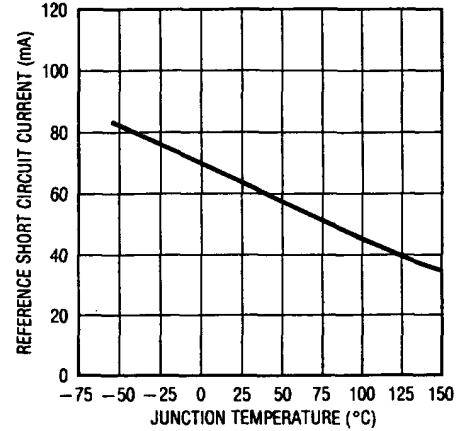

Reference Ripple Rejection

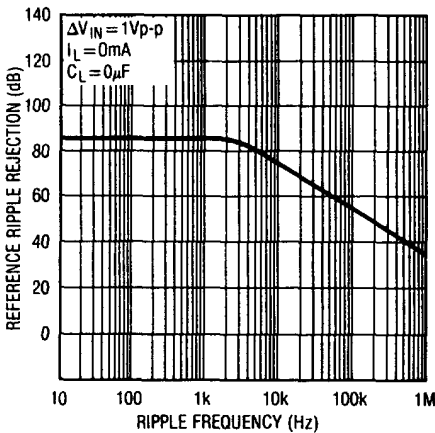

Current Limit Comparator Transfer Function

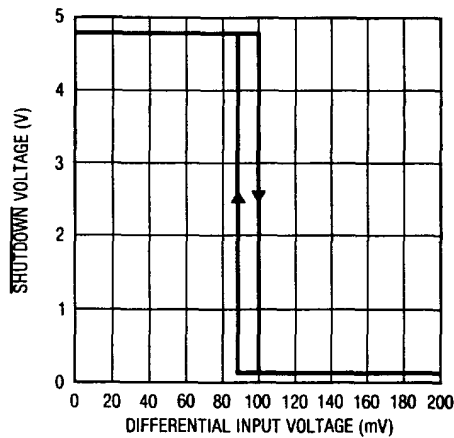

Current Limit Comparator Sense Voltage

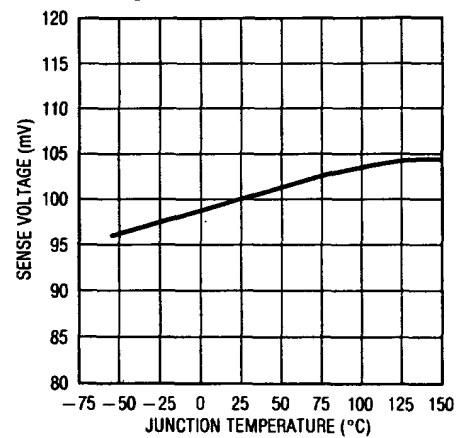

Oscillator Period vs R_T and C_T

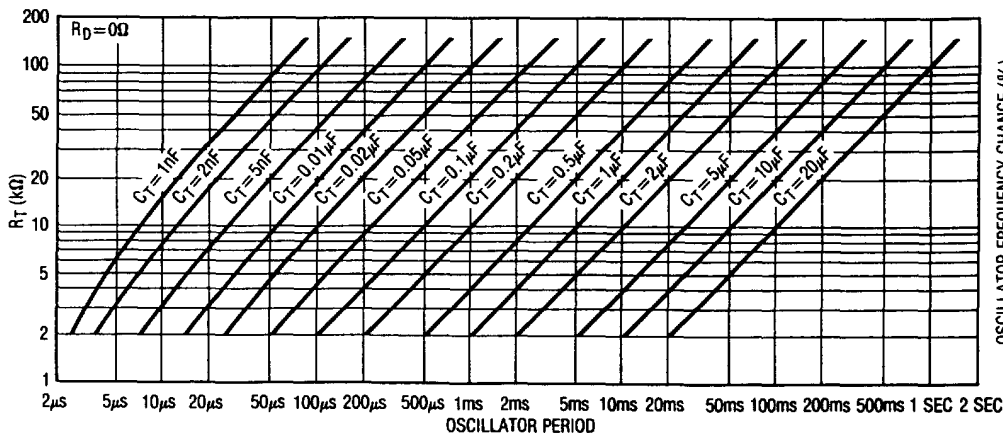

Oscillator Frequency Temperature Stability

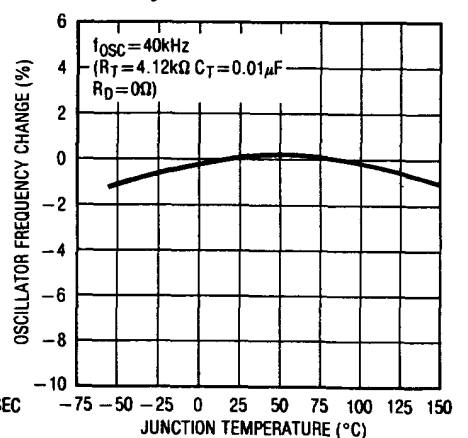

TYPICAL PERFORMANCE CHARACTERISTICS

Error Amplifier Open Loop Gain vs Frequency

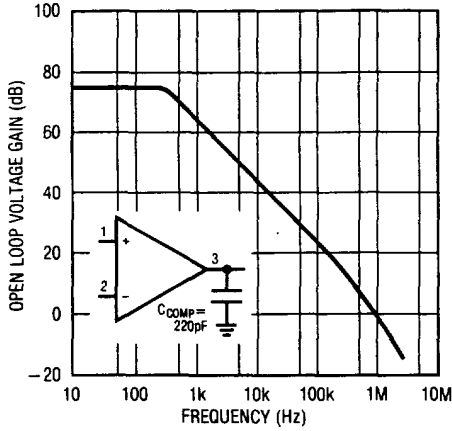

Soft-start Time Constant vs C_S

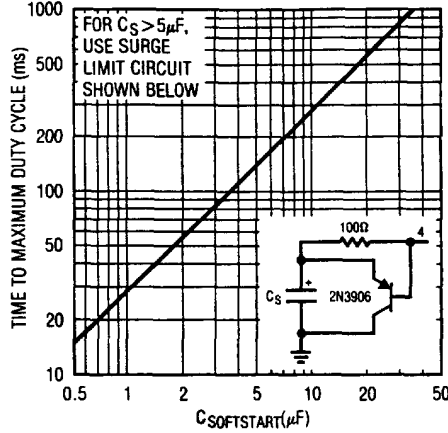

Undervoltage Lockout Characteristic

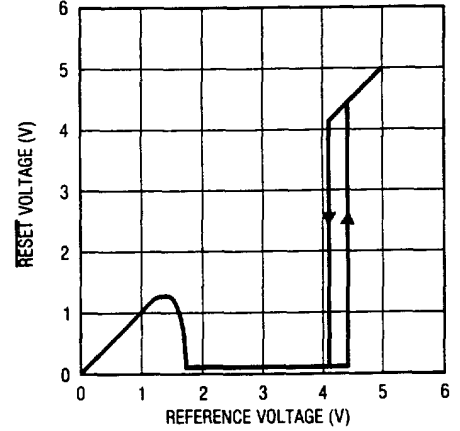

Standby Current vs Supply Voltage

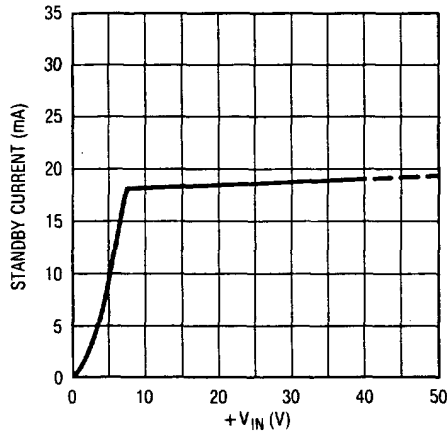

+V_{COLLECTOR} Current (Note 9)

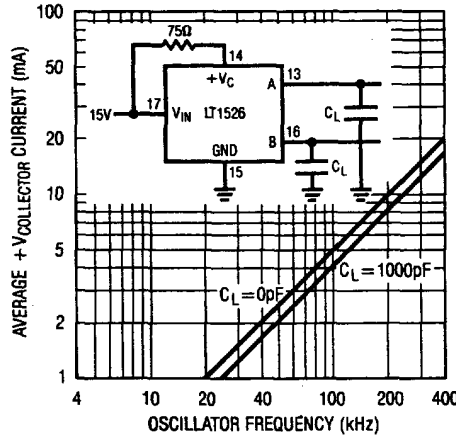

Output Driver Deadtime vs R_D

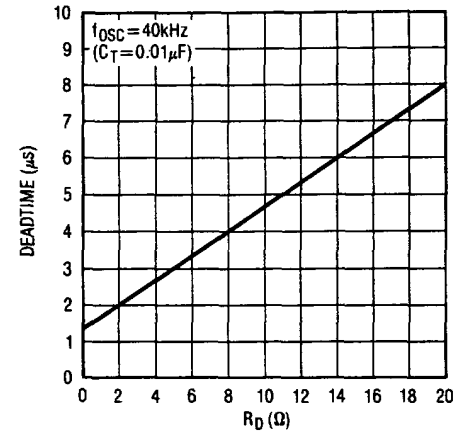

NOTE 9: TRANSIENT CURRENTS OCCUR WITHIN THE OUTPUT STAGES DURING SWITCHING, INDEPENDENT OF LOADING. THE GRAPH SHOWS THE AVERAGE (DC) VALUE OF THE TRANSIENT CURRENTS.

Output Driver Shutdown Delay

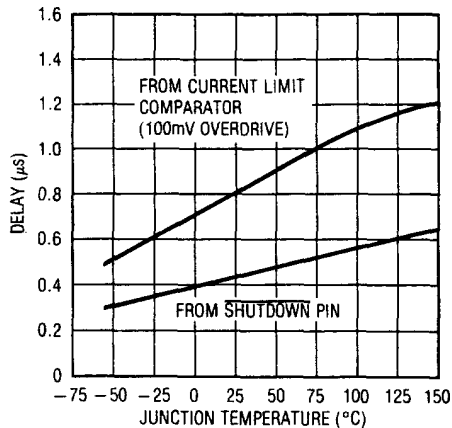

Output Driver Saturation Voltage vs I_{SINK}

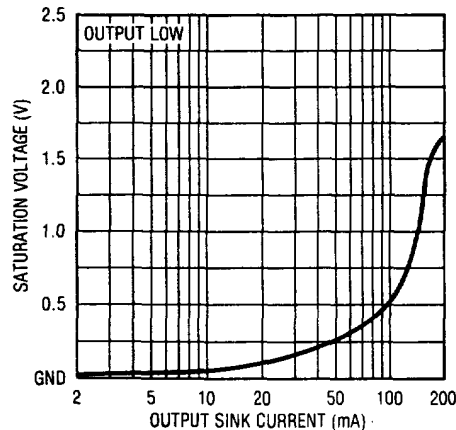

Output Driver Saturation Voltage vs I_{SOURCE}

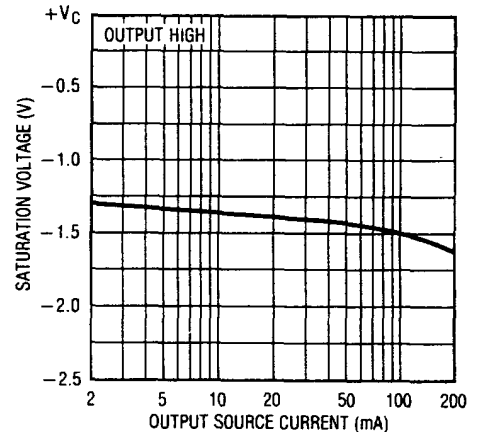

5

APPLICATIONS INFORMATION

FUNCTIONAL DESCRIPTION AND PIN FUNCTION

Voltage Reference

The reference regulator (pin 18) supplies a regulated 5.0V to all internal circuitry, as well as up to 20mA for external circuitry. It is fully active at supply voltages (pin 17) of 8V and greater.

The LT1526 can operate from a 5V supply by connecting +V_{IN} to V_{REF} (pin 18 to pin 17) and maintaining the supply between 4.8V and 5.2V.

Undervoltage Lockout

The undervoltage lockout circuitry protects both the switching regulator and the power devices it controls from inadequate supply voltage, which can result in unstable control circuitry. If +V_{IN} is too low, the circuit turns off the output drivers, holds RESET (pin 5) low and the soft-start capacitor in a discharged state.

Soft-Start

The soft-start circuitry protects the power devices from high surge currents during power supply turn-on by limiting the available PWM duty cycle.

When +V_{IN} reaches a sufficient voltage to allow RESET to go high, a 100 μ A current source charges the external C_S capacitor (pin 4) linearly to 5V. The ERROR AMPLIFIER output is clamped to 600mV above the C_S voltage, and the available duty cycle of the PWM increases linearly. Maximum duty cycle is available when the C_S voltage reaches about 3V.

Digital Control Ports

The three digital control ports are bidirectional. Each port can drive TTL and 5V CMOS logic directly. They can also be driven by open-collector TTL, open-drain CMOS, and open-collector voltage comparators.

Driving SYNC (pin 12) low causes a discharge cycle in the oscillator. Driving SHUTDOWN (pin 8) low causes the outputs to turn off. Driving RESET (pin 5) low causes the outputs to turn off and discharges the C_S capacitor.

Oscillator

The internal oscillator circuitry sets the frequency of operation for the switching regulator. Frequency is set by R_T (pin 9), C_T (pin 10), and R_D (pin 11). With R_D=0 Ω , the values for R_T and C_T may be chosen from the oscillator period graph. If the desired deadtime is increased, the value of R_T may need to be decreased to maintain the desired frequency.

The frequency at either output is half that of the oscillator, and the frequency at +V_C (pin 14) is equal to the oscillator.

Synchronous Operation

Two or more switching regulators may be synchronized by setting the master to the desired frequency and sharing the oscillator signals with the slave units. Slave C_T pins are tied to the master C_T pin, and slave SYNC pins are tied to the master SYNC pin. Slave R_T and R_D pins are left open.

External logic synchronization can be used by setting the oscillator period to be 10% longer than the external clock period, and connecting the external clock to the SYNC pin. A periodic low of about 0.5 μ s wide will lock the oscillator to the external frequency.

Error Amplifier

The differential input (pins 1 and 2), single-ended output (pin 3) transconductance amplifier provides about 70dB of gain. The output has an impedance of 2M Ω , and since all voltage gain occurs at the output, the gain characteristics can be controlled with shunt reactance to ground.

Output Drivers

The totem-pole output drivers can source and sink 100mA continuously and 200mA peak. The outputs are driven 180° out of phase by the flip-flop. Loads can be driven either from the outputs or the +V_C pin. Since large transient currents occur within the output stages during switching, a resistor is recommended in series with +V_C (pin 14) to limit the peak current. The resistor value should be +V_C/200mA.

APPLICATIONS INFORMATION

Current Limit

The current limit comparator turns off the outputs when the input voltage (pin 7 to pin 6) exceeds 100mV. Hysteresis is built into the trip point, of about 10mV, to prevent oscillations.

sis is built into the trip point, of about 10mV, to prevent oscillations.

TYPICAL APPLICATIONS

Single Ended Supply

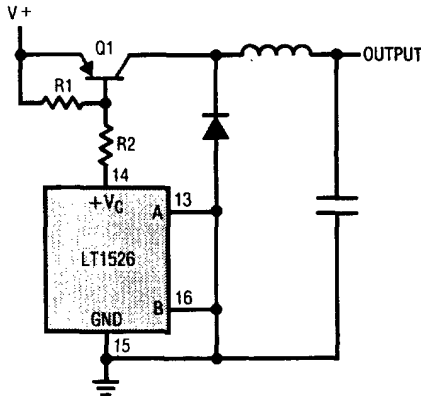

FOR SINGLE ENDED SUPPLIES, THE DRIVER OUTPUTS ARE GROUNDED. THE +V_C TERMINAL IS SWITCHED TO GROUND BY THE TOTEM POLE SOURCE TRANSISTORS ON EVERY OSCILLATOR CYCLE.

Bipolar Push-Pull Supply

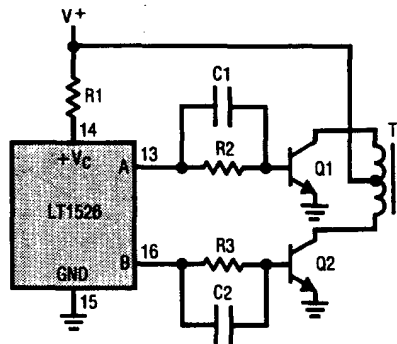

IN CONVENTIONAL BIPOLAR PUSH-PULL DESIGNS, FORWARD BASE DRIVE IS CONTROLLED BY R1-R3. RAPID TURN-OFF TIMES FOR THE POWER DEVICES ARE ACHIEVED WITH SPEED-UP CAPACITORS C1 AND C2.

Driving Transformers Directly

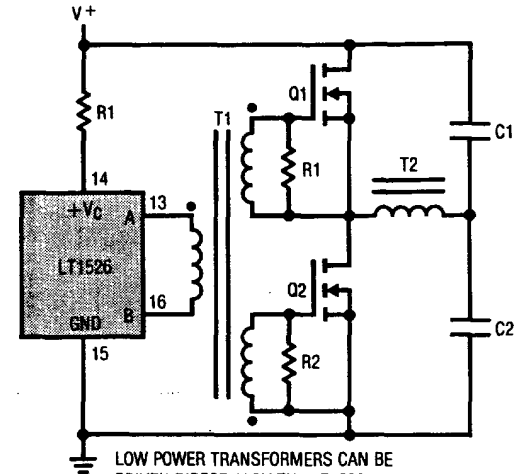

LOW POWER TRANSFORMERS CAN BE DRIVEN DIRECTLY BY THE LT1526. AUTOMATIC RESET OCCURS DURING DEAD-TIME, WHEN BOTH ENDS OF THE PRIMARY WINDING ARE SWITCHED TO GROUND.

5

Power FETs Push-Pull Supply

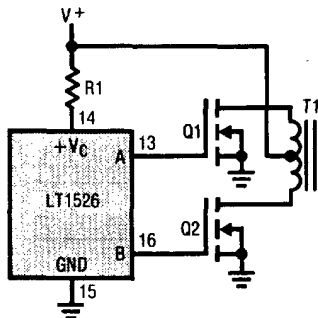

THE LOW SOURCE IMPEDANCE OF THE OUTPUT DRIVERS PROVIDES RAPID CHARGING OF POWER FET INPUT CAPACITANCE, WHILE MINIMIZING EXTERNAL COMPONENTS.

Extending Reference Output Current

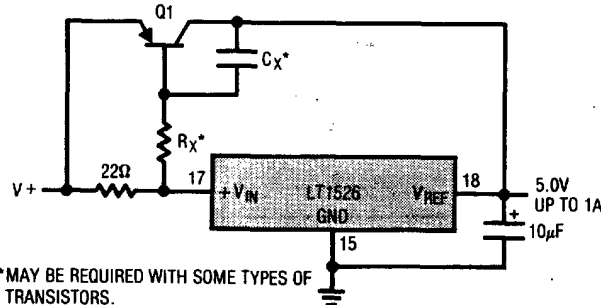

*MAY BE REQUIRED WITH SOME TYPES OF TRANSISTORS.

Oscillator Connections

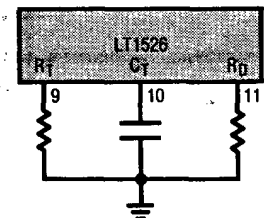

Error Amplifier Connections

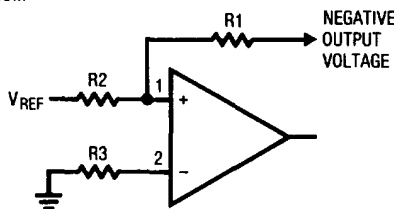

$$V_{OUT} = V_{REF} \left(\frac{R1}{R2} \right)$$

$$R3 = \left(\frac{R1R2}{R1 + R2} \right)$$

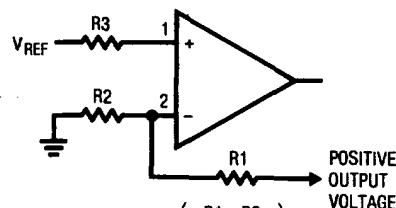

$$V_{OUT} = V_{REF} \left(\frac{R1 + R2}{R2} \right)$$

$$R3 = \left(\frac{R1R2}{R1 + R2} \right)$$

TYPICAL APPLICATIONS

LT1526 Lab Test Fixture

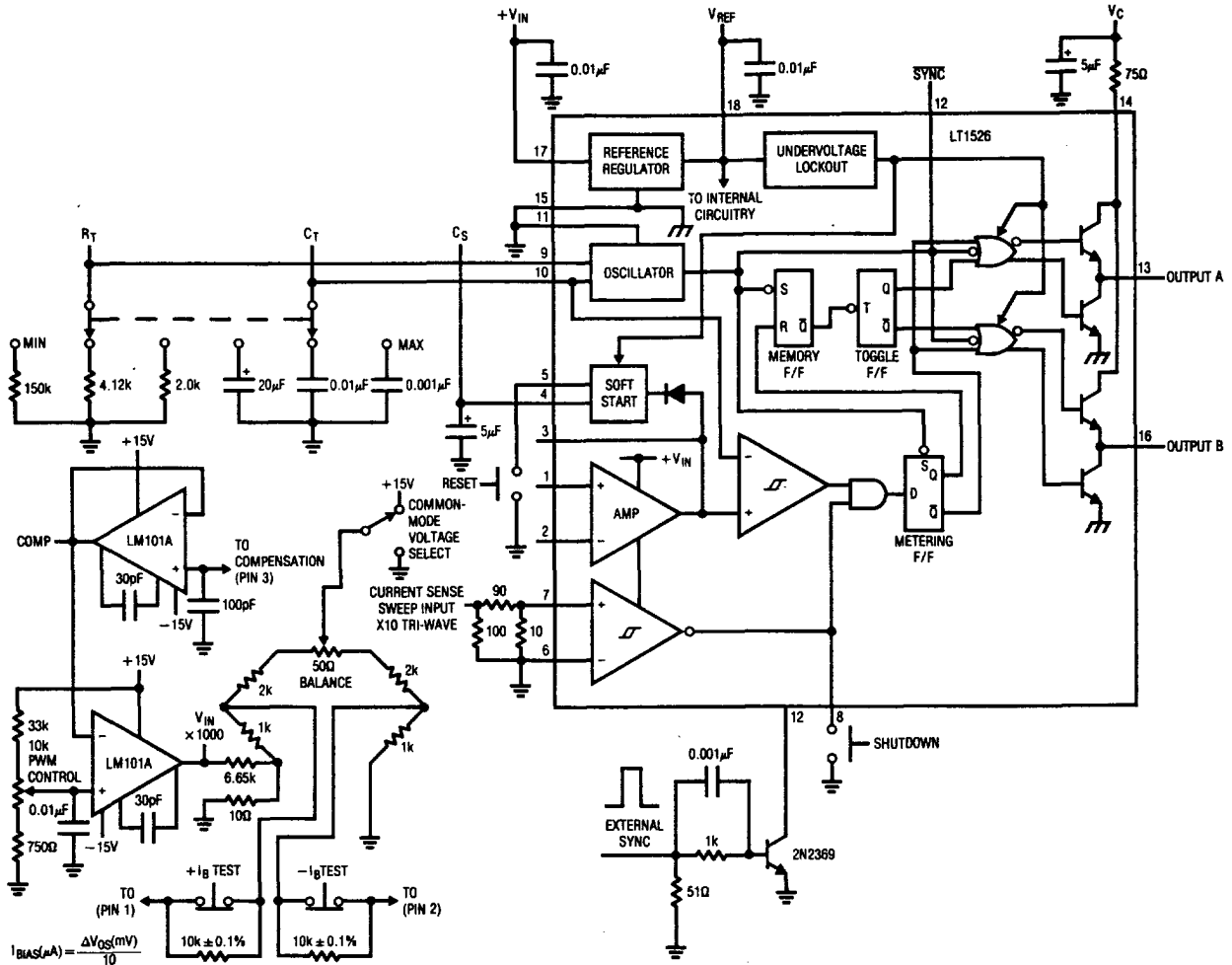

PACKAGE DESCRIPTION

J Package 18 Lead Ceramic DIP

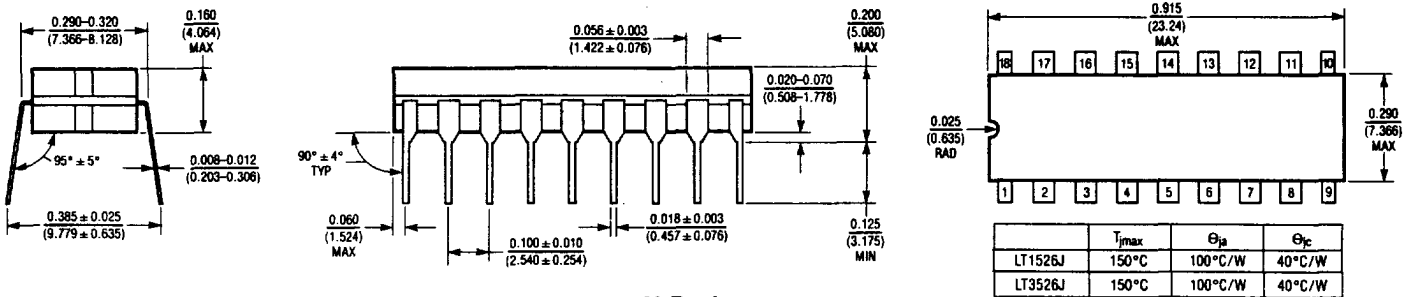

N Package 18 Lead Plastic DIP

