

**CD4051BM/CD4051BC Single 8-Channel Analog Multiplexer/Demultiplexer**  
**CD4052BM/CD4052BC Dual 4-Channel Analog Multiplexer/Demultiplexer**  
**CD4053BM/CD4053BC Triple 2-Channel Analog Multiplexer/Demultiplexer**

**General Description**

These analog multiplexers/demultiplexers are digitally controlled analog switches having low "ON" impedance and very low "OFF" leakage currents. Control of analog signals up to 15V<sub>p-p</sub> can be achieved by digital signal amplitudes of 3–15V. For example, if V<sub>DD</sub> = 5V, V<sub>SS</sub> = 0V and V<sub>EE</sub> = -5V, analog signals from -5V to +5V can be controlled by digital inputs of 0–5V. The multiplexer circuits dissipate extremely low quiescent power over the full V<sub>DD</sub>–V<sub>SS</sub> and V<sub>DD</sub>–V<sub>EE</sub> supply voltage ranges, independent of the logic state of the control signals. When a logical "1" is present at the inhibit input terminal all channels are "OFF".

CD4051BM/CD4051BC is a single 8-channel multiplexer having three binary control inputs, A, B, and C, and an inhibit input. The three binary signals select 1 of 8 channels to be turned "ON" and connect the input to the output.

CD4052BM/CD4052BC is a differential 4-channel multiplexer having two binary control inputs, A and B, and an inhibit input. The two binary input signals select 1 or 4 pairs of channels to be turned on and connect the differential analog inputs to the differential outputs.

CD4053BM/CD4053BC is a triple 2-channel multiplexer having three separate digital control inputs, A, B, and C, and

an inhibit input. Each control input selects one of a pair of channels which are connected in a single-pole double-throw configuration.

**Features**

- Wide range of digital and analog signal levels: digital 3–15V, analog to 15V<sub>p-p</sub>
- Low "ON" resistance: 80Ω (typ.) over entire 15V<sub>p-p</sub> signal-input range for V<sub>DD</sub>–V<sub>EE</sub> = 15V
- High "OFF" resistance: channel leakage of ±10 pA (typ.) at V<sub>DD</sub>–V<sub>EE</sub> = 10V
- Logic level conversion for digital addressing signals of 3–15V (V<sub>DD</sub>–V<sub>SS</sub> = 3–15V) to switch analog signals to 15 V<sub>p-p</sub> (V<sub>DD</sub>–V<sub>EE</sub> = 15V)
- Matched switch characteristics: ΔR<sub>ON</sub> = 5Ω (typ.) for V<sub>DD</sub>–V<sub>EE</sub> = 15V
- Very low quiescent power dissipation under all digital-control input and supply conditions: 1 μW (typ.) at V<sub>DD</sub>–V<sub>SS</sub> = V<sub>DD</sub>–V<sub>EE</sub> = 10V
- Binary address decoding on chip

**Connection Diagrams**

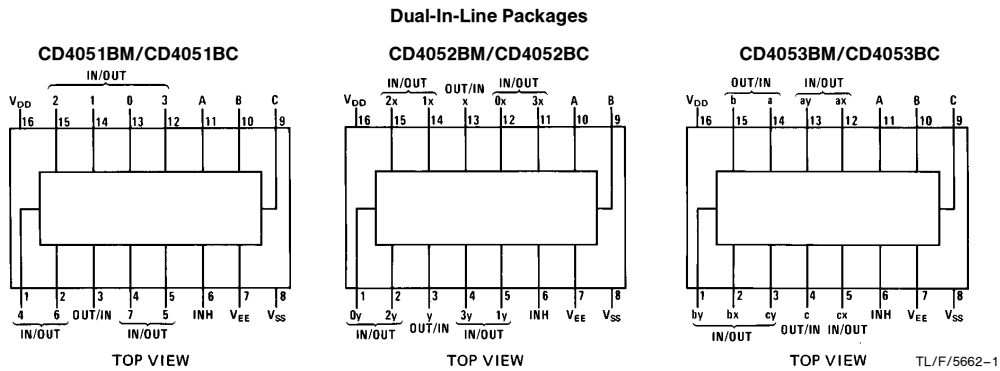

Order Number CD4051B, CD4052B, or CD4053B

## Absolute Maximum Ratings

If Military/Aerospace specified devices are required, please contact the National Semiconductor Sales Office/Distributors for availability and specifications.

DC Supply Voltage ( $V_{DD}$ )	-0.5 $V_{DC}$ to +18 $V_{DC}$
Input Voltage ( $V_{IN}$ )	-0.5 $V_{DC}$ to $V_{DD}$ + 0.5 $V_{DC}$
Storage Temperature Range ( $T_S$ )	-65°C to +150°C
Power Dissipation ( $P_D$ )	
Dual-In-Line	700 mW
Small Outline	500 mW
Lead Temp. ( $T_L$ ) (soldering, 10 sec.)	260°C

## Recommended Operating Conditions

DC Supply Voltage ( $V_{DD}$ )	+5 $V_{DC}$ to +15 $V_{DC}$
Input Voltage ( $V_{IN}$ )	0V to $V_{DD}$ $V_{DC}$
Operating Temperature Range ( $T_A$ )	
4051BM/4052BM/4053BM	-55°C to +125°C
4051BC/4052BC/4053BC	-40°C to +85°C

## DC Electrical Characteristics (Note 2)

Symbol	Parameter	Conditions	-55°C		+25°			+125°C		Units
			Min	Max	Min	Typ	Max	Min	Max	
$I_{DD}$	Quiescent Device Current	$V_{DD}=5V$		5			5		150	$\mu A$
		$V_{DD}=10V$		10			10		300	$\mu A$
		$V_{DD}=15V$		20			20		600	$\mu A$

### Signal Inputs ( $V_{IS}$ ) and Outputs ( $V_{OS}$ )

$R_{ON}$	"ON" Resistance (Peak for $V_{EE} \leq V_{IS} \leq V_{DD}$ )	$R_L = 10 \text{ k}\Omega$ (any channel selected)	$V_{DD}=2.5V$ , $V_{EE}=-2.5V$ or $V_{DD}=5V$ , $V_{EE}=0V$		800		270	1050		1300	$\Omega$
			$V_{DD}=5V$ $V_{EE}=-5V$ or $V_{DD}=10V$ , $V_{EE}=0V$		310		120	400		550	$\Omega$
			$V_{DD}=7.5V$ , $V_{EE}=-7.5V$ or $V_{DD}=15V$ , $V_{EE}=0V$		200		80	240		320	$\Omega$
$\Delta R_{ON}$	$\Delta$ "ON" Resistance Between Any Two Channels	$R_L = 10 \text{ k}\Omega$ (any channel selected)	$V_{DD}=2.5V$ , $V_{EE}=-2.5V$ or $V_{DD}=5V$ , $V_{EE}=0V$				10				$\Omega$
			$V_{DD}=5V$ , $V_{EE}=-5V$ or $V_{DD}=10V$ , $V_{EE}=0V$				10				$\Omega$
			$V_{DD}=7.5V$ , $V_{EE}=-7.5V$ or $V_{DD}=15V$ , $V_{EE}=0V$				5				$\Omega$
	"OFF" Channel Leakage Current, any channel "OFF"	$V_{DD}=7.5V$ , $V_{EE}=-7.5V$ $O/I = \pm 7.5V$ , $I/O = 0V$		$\pm 50$		$\pm 0.01$	$\pm 50$		$\pm 500$	nA	
"OFF" Channel Leakage Current, all channels "OFF" (Common OUT/IN)	Inhibit = 7.5V $V_{DD}=7.5V$ , $V_{EE}=-7.5V$ , $O/I=0V$ , $I/O = \pm 7.5V$	CD4051	$\pm 200$		$\pm 0.08$	$\pm 200$		$\pm 2000$	nA		
		CD4052	$\pm 200$		$\pm 0.04$	$\pm 200$		$\pm 2000$	nA		
		CD4053	$\pm 200$		$\pm 0.02$	$\pm 200$		$\pm 2000$	nA		

### Control Inputs A, B, C and Inhibit

$V_{IL}$	Low Level Input Voltage	$V_{EE}=V_{SS}$ $R_L=1 \text{ k}\Omega$ to $V_{SS}$ $I_{IS} < 2 \mu A$ on all OFF channels $V_{IS}=V_{DD}$ thru $1 \text{ k}\Omega$ $V_{DD}=5V$ $V_{DD}=10V$ $V_{DD}=15V$								
				1.5			1.5		1.5	V
				3.0			3.0		3.0	V
				4.0			4.0		4.0	V
$V_{IH}$	High Level Input Voltage	$V_{DD}=5$ $V_{DD}=10$ $V_{DD}=15$	3.5		3.5			3.5	V	
			7		7			7	V	
			11		11			11	V	

**Note 1:** "Absolute Maximum Ratings" are those values beyond which the safety of the device cannot be guaranteed. Except for "Operating Temperature Range" they are not meant to imply that the devices should be operated at these limits. The table of "Electrical Characteristics" provides conditions for actual device operation.

**Note 2:** All voltages measured with respect to  $V_{SS}$  unless otherwise specified.

## DC Electrical Characteristics (Note 2) (Continued)

Symbol	Parameter	Conditions	-40°C		+25°C			+85°C		Units	
			Min	Max	Min	Typ	Max	Min	Max		
I <sub>IN</sub>	Input Current	V <sub>DD</sub> = 15V, V <sub>EE</sub> = 0V V <sub>IN</sub> = 0V		-0.1		-10 <sup>-5</sup>	-0.1		-1.0	μA	
		V <sub>DD</sub> = 15V, V <sub>EE</sub> = 0V V <sub>IN</sub> = 15V		0.1		10 <sup>-5</sup>	0.1		1.0	μA	
I <sub>DD</sub>	Quiescent Device Current	V <sub>DD</sub> = 5V		20			20		150	μA	
		V <sub>DD</sub> = 10V		40			40		300	μA	
		V <sub>DD</sub> = 15V		80			80		600	μA	
<b>Signal Inputs (V<sub>IS</sub>) and Outputs (V<sub>OS</sub>)</b>											
R <sub>ON</sub>	"ON" Resistance (Peak for V <sub>EE</sub> ≤ V <sub>IS</sub> ≤ V <sub>DD</sub> )	R <sub>L</sub> = 10 kΩ (any channel selected)	V <sub>DD</sub> = 2.5V, V <sub>EE</sub> = -2.5V or V <sub>DD</sub> = 5V, V <sub>EE</sub> = 0V		850		270	1050		1200	Ω
		V <sub>DD</sub> = 5V, V <sub>EE</sub> = -5V or V <sub>DD</sub> = 10V, V <sub>EE</sub> = 0V		330		120	400		520	Ω	
		V <sub>DD</sub> = 7.5V, V <sub>EE</sub> = -7.5V or V <sub>DD</sub> = 15V, V <sub>EE</sub> = 0V		210		80	240		300	Ω	
ΔR <sub>ON</sub>	Δ"ON" Resistance Between Any Two Channels	R <sub>L</sub> = 10 kΩ (any channel selected)	V <sub>DD</sub> = 2.5V, V <sub>EE</sub> = -2.5V or V <sub>DD</sub> = 5V, V <sub>EE</sub> = 0V				10			Ω	
			V <sub>DD</sub> = 5V, V <sub>EE</sub> = -5V or V <sub>DD</sub> = 10V, V <sub>EE</sub> = 0V				10			Ω	
			V <sub>DD</sub> = 7.5V, V <sub>EE</sub> = -7.5V or V <sub>DD</sub> = 15V, V <sub>EE</sub> = 0V				5			Ω	
	"OFF" Channel Leakage Current, any channel "OFF"	V <sub>DD</sub> = 7.5V, V <sub>EE</sub> = -7.5V O/I = ±7.5V, I/O = 0V		±50		±0.01	±50		±500	nA	
	"OFF" Channel Leakage Current, all channels "OFF" (Common OUT/IN)	Inhibit = 7.5V CD4051		±200		±0.08	±200		±2000	nA	
V <sub>DD</sub> = 7.5V, V <sub>EE</sub> = -7.5V, O/I = 0V CD4052			±200		±0.04	±200		±2000	nA		
I/O = ±7.5V CD4053			±200		±0.02	±200		±2000	nA		
<b>Control Inputs A, B, C and Inhibit</b>											
V <sub>IL</sub>	Low Level Input Voltage	V <sub>EE</sub> = V <sub>SS</sub> R <sub>L</sub> = 1 kΩ to V <sub>SS</sub> I <sub>IS</sub> < 2 μA on all OFF Channels V <sub>IS</sub> = V <sub>DD</sub> thru 1 kΩ V <sub>DD</sub> = 5V V <sub>DD</sub> = 10V V <sub>DD</sub> = 15V		1.5 3.0 4.0			1.5 3.0 4.0		1.5 3.0 4.0	V	
V <sub>IH</sub>	High Level Input Voltage	V <sub>DD</sub> = 5 V <sub>DD</sub> = 10 V <sub>DD</sub> = 15	3.5 7 11		3.5 7 11				3.5 7 11	V	
I <sub>IN</sub>	Input Current	V <sub>DD</sub> = 15V, V <sub>EE</sub> = 0V V <sub>IN</sub> = 0V		-0.1		-10 <sup>-5</sup>	-0.1		-1.0	μA	
		V <sub>DD</sub> = 15V, V <sub>EE</sub> = 0V V <sub>IN</sub> = 15V		0.1		10 <sup>-5</sup>	0.1		1.0	μA	
<p><b>Note 1:</b> "Absolute Maximum Ratings" are those values beyond which the safety of the device cannot be guaranteed. Except for "Operating Temperature Range" they are not meant to imply that the devices should be operated at these limits. The table of "Electrical Characteristics" provides conditions for actual device operation.</p> <p><b>Note 2:</b> All voltages measured with respect to V<sub>SS</sub> unless otherwise specified.</p>											

## AC Electrical Characteristics\* $T_A = 25^\circ\text{C}$ , $t_r = t_f = 20\text{ ns}$ , unless otherwise specified.

Symbol	Parameter	Conditions	$V_{DD}$	Min	Typ	Max	Units
$t_{PZH}$ , $t_{PZL}$	Propagation Delay Time from Inhibit to Signal Output (channel turning on)	$V_{EE} = V_{SS} = 0V$ $R_L = 1\text{ k}\Omega$ $C_L = 50\text{ pF}$	5V 10V 15V		600 225 160	1200 450 320	ns ns ns
$t_{PHZ}$ , $t_{PLZ}$	Propagation Delay Time from Inhibit to Signal Output (channel turning off)	$V_{EE} = V_{SS} = 0V$ $R_L = 1\text{ k}\Omega$ $C_L = 50\text{ pF}$	5V 10V 15V		210 100 75	420 200 150	ns ns ns
$C_{IN}$	Input Capacitance Control input Signal Input (IN/OUT)				5 10	7.5 15	pF pF
$C_{OUT}$	Output Capacitance (common OUT/IN)						
	CD4051 CD4052 CD4053	$V_{EE} = V_{SS} = 0V$	10V 10V 10V		30 15 8		pF pF pF
$C_{IOS}$	Feedthrough Capacitance				0.2		pF
$C_{PD}$	Power Dissipation Capacitance						
	CD4051 CD4052 CD4053				110 140 70		pF pF pF
<b>Signal Inputs (<math>V_{IS}</math>) and Outputs (<math>V_{OS}</math>)</b>							
	Sine Wave Response (Distortion)	$R_L = 10\text{ k}\Omega$ $f_{IS} = 1\text{ kHz}$ $V_{IS} = 5\text{ V}_{p-p}$ $V_{EE} = V_{SI} = 0V$	10V		0.04		%
	Frequency Response, Channel "ON" (Sine Wave Input)	$R_L = 1\text{ k}\Omega$ , $V_{EE} = 0V$ , $V_{IS} = 5\text{ V}_{p-p}$ , $20 \log_{10} V_{OS}/V_{IS} = -3\text{ dB}$	10V		40		MHz
	Feedthrough, Channel "OFF"	$R_L = 1\text{ k}\Omega$ , $V_{EE} = V_{SS} = 0V$ , $V_{IS} = 5\text{ V}_{p-p}$ , $20 \log_{10} V_{OS}/V_{IS} = -40\text{ dB}$	10V		10		MHz
	Crosstalk Between Any Two Channels (frequency at 40 dB)	$R_L = 1\text{ k}\Omega$ , $V_{EE} = V_{SS} = 0V$ , $V_{IS}(A) = 5\text{ V}_{p-p}$ , $20 \log_{10} V_{OS}(B)/V_{IS}(A) = -40\text{ dB}$ (Note 3)	10V		3		MHz
$t_{PHL}$ , $t_{PLH}$	Propagation Delay Signal Input to Signal Output	$V_{EE} = V_{SS} = 0V$ $C_L = 50\text{ pF}$	5V 10V 15V		25 15 10	55 35 25	ns ns ns
<b>Control Inputs, A, B, C and Inhibit</b>							
	Control Input to Signal Crosstalk	$V_{EE} = V_{SS} = 0V$ , $R_L = 10\text{ k}\Omega$ at both ends of channel. Input Square Wave Amplitude = 10V	10V		65		mV (peak)
$t_{PHL}$ , $t_{PLH}$	Propagation Delay Time from Address to Signal Output (channels "ON" or "OFF")	$V_{EE} = V_{SS} = 0V$ $C_L = 50\text{ pF}$	5V 10V 15V		500 180 120	1000 360 240	ns ns ns
*AC Parameters are guaranteed by DC correlated testing. <b>Note 3:</b> A, B are two arbitrary channels with A turned "ON" and B "OFF".							

# Block Diagrams

CD4051BM/CD4051BC

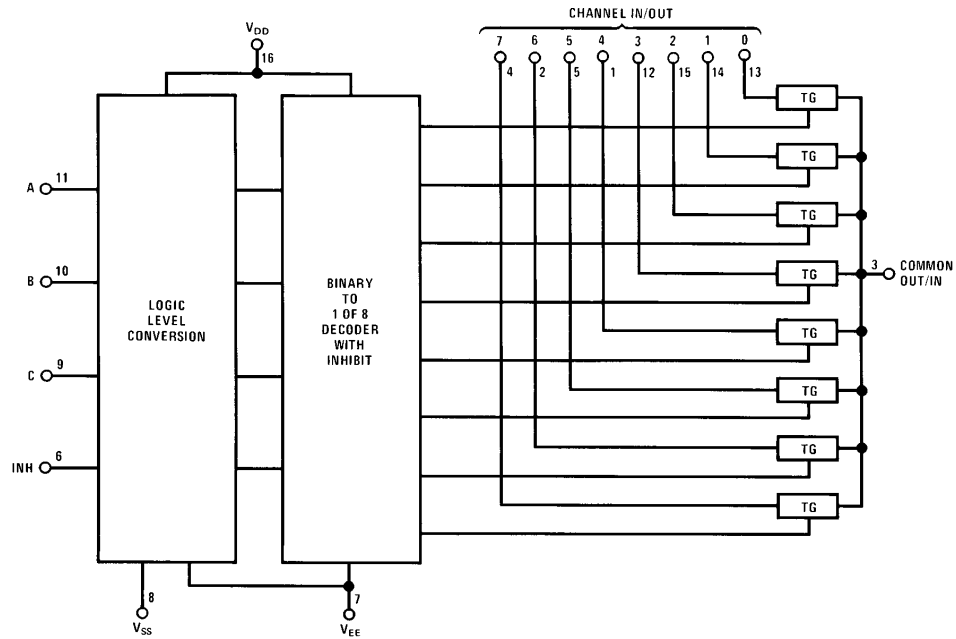

CD4052BM/CD4052BC

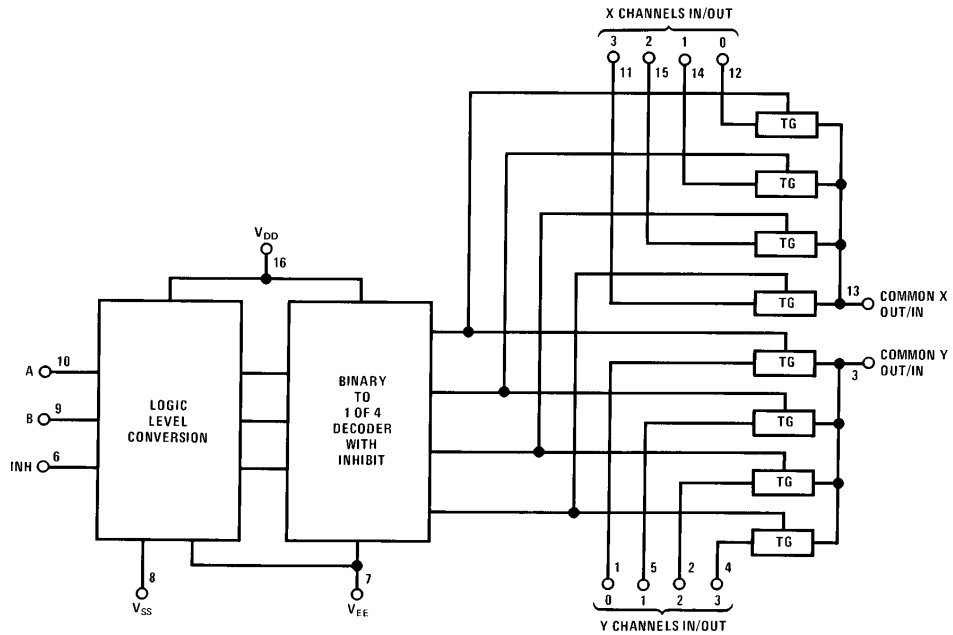

TL/F/5662-2

## Block Diagrams (Continued)

### CD4053BM/CD4053BC

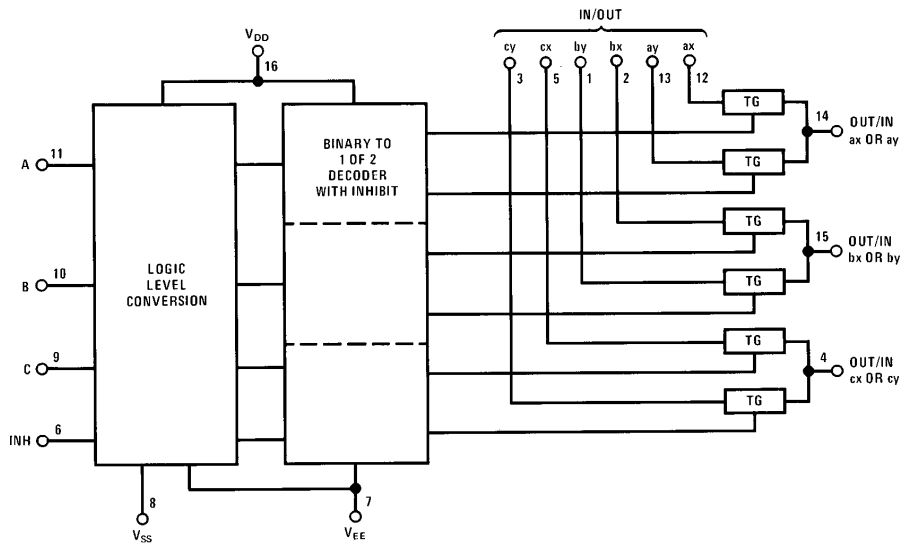

TL/F/5662-3

## Truth Table

INPUT STATES				"ON" CHANNELS		
INHIBIT	C	B	A	CD4051B	CD4052B	CD4053B
0	0	0	0	0	0X, 0Y	cx, bx, ax
0	0	0	1	1	1X, 1Y	cx, bx, ay
0	0	1	0	2	2X, 2Y	cx, by, ax
0	0	1	1	3	3X, 3Y	cx, by, ay
0	1	0	0	4		cy, bx, ax
0	1	0	1	5		cy, bx, ay
0	1	1	0	6		cy, by, ax
0	1	1	1	7		cy, by, ay
1	*	*	*	NONE	NONE	NONE

\*Don't Care condition.

## Switching Time Waveforms

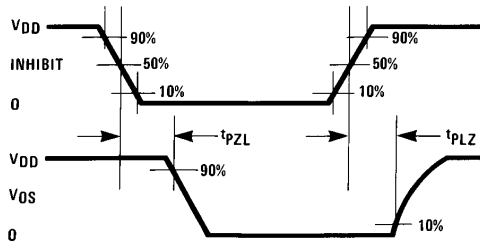
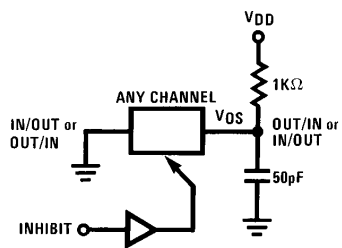
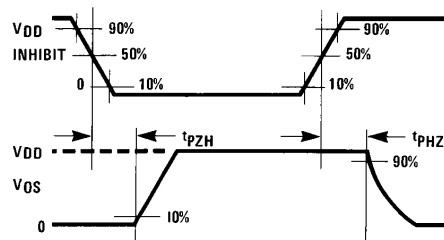
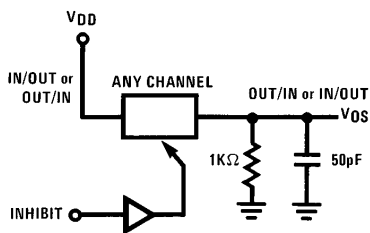
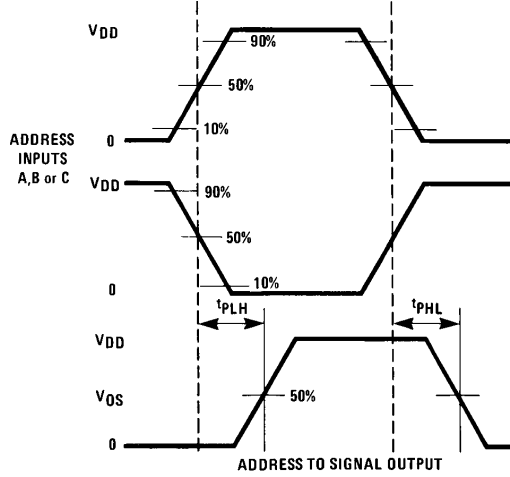
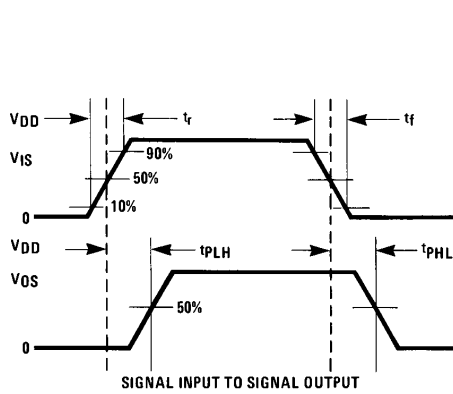

TL/F/5662-4

## Special Considerations

In certain applications the external load-resistor current may include both  $V_{DD}$  and signal-line components. To avoid drawing  $V_{DD}$  current when switch current flows into IN/OUT pin, the voltage drop across the bidirectional switch must

not exceed 0.6V at  $T_A \leq 25^\circ\text{C}$ , or 0.4V at  $T_A > 25^\circ\text{C}$  (calculated from  $R_{ON}$  values shown). No  $V_{DD}$  current will flow through  $R_L$  if the switch current flows into OUT/IN pin.

## Typical Performance Characteristics

“ON” Resistance vs Signal Voltage for  $T_A = 25^\circ\text{C}$

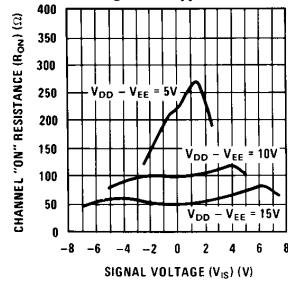

“ON” Resistance as a Function of Temperature for  $V_{DD} - V_{EE} = 15V$

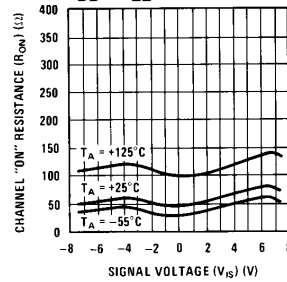

“ON” Resistance as a Function of Temperature for  $V_{DD} - V_{EE} = 10V$

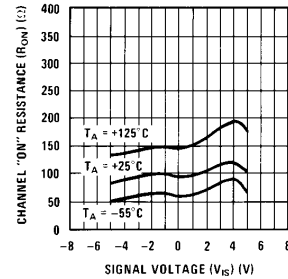

“ON” Resistance as a Function of Temperature for  $V_{DD} - V_{EE} = 5V$

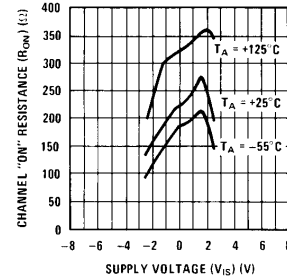

TL/F/5662-5



**Physical Dimensions** inches (millimeters)

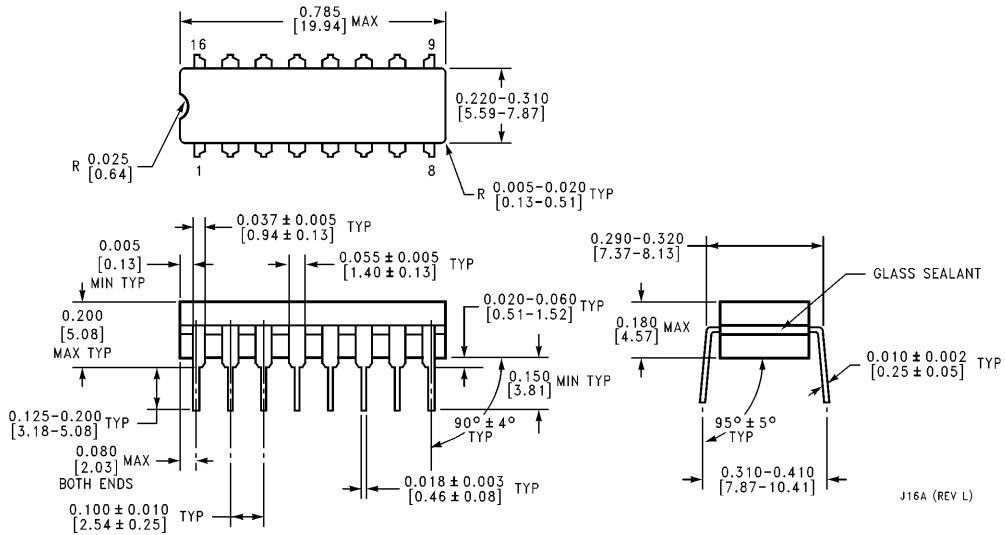

**Cavity Dual-In-Line Package (J)**  
**Order Number CD4051BMJ, CD4051BCJ, CD4052BMJ,**  
**CD4052BCJ, CD4053BMJ or CD4053BCJ**  
**NS Package Number J16A**

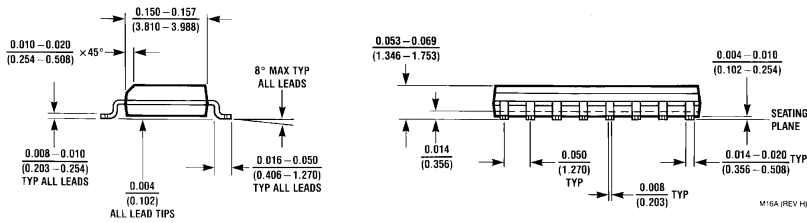
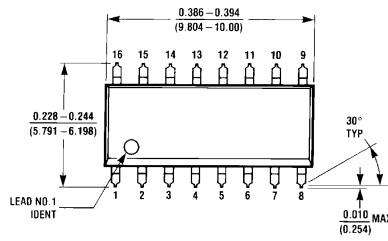

**Small Outline Package (M)**  
**Order Number CD4051BCM,**  
**CD4052BCM or CD4053BCM**  
**NS Package Number M16A**

**Physical Dimensions** inches (millimeters) (Continued)

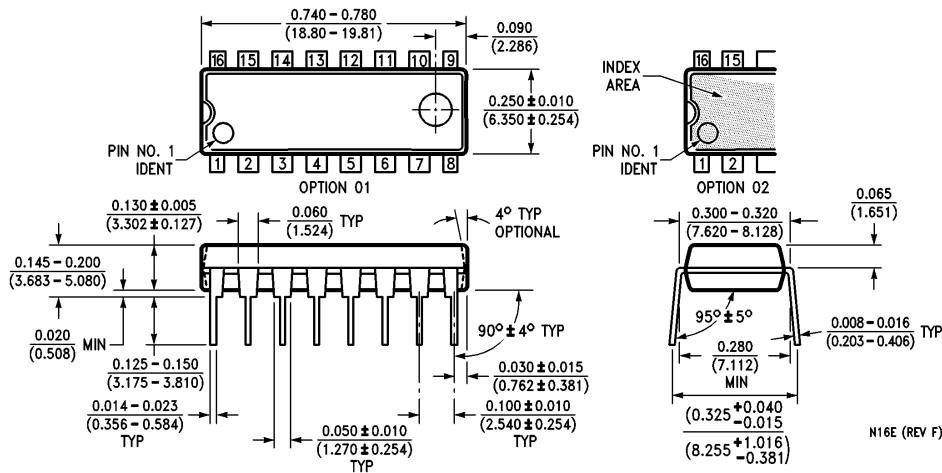

**Molded Dual-In-Line Package (N)**  
**Order CD4051BM, CD4051BC,**  
**CD4052BM, CD4052BC, CD4053BM, CD4053BC**  
**NS Package Number N16E**

N16E (REV F)

**LIFE SUPPORT POLICY**

NATIONAL'S PRODUCTS ARE NOT AUTHORIZED FOR USE AS CRITICAL COMPONENTS IN LIFE SUPPORT DEVICES OR SYSTEMS WITHOUT THE EXPRESS WRITTEN APPROVAL OF THE PRESIDENT OF NATIONAL SEMICONDUCTOR CORPORATION. As used herein:

1. Life support devices or systems are devices or systems which, (a) are intended for surgical implant into the body, or (b) support or sustain life, and whose failure to perform, when properly used in accordance with instructions for use provided in the labeling, can be reasonably expected to result in a significant injury to the user.
2. A critical component is any component of a life support device or system whose failure to perform can be reasonably expected to cause the failure of the life support device or system, or to affect its safety or effectiveness.



**National Semiconductor Corporation**  
 1111 West Bardin Road  
 Arlington, TX 76017  
 Tel: 1(800) 272-9959  
 Fax: 1(800) 737-7018

**National Semiconductor Europe**  
 Fax: (+49) 0-180-530 85 86  
 Email: onjwge@tevm2.nsc.com  
 Deutsch Tel: (+49) 0-180-530 85 85  
 English Tel: (+49) 0-180-532 78 32  
 Français Tel: (+49) 0-180-532 93 58  
 Italiano Tel: (+49) 0-180-534 16 80

**National Semiconductor Hong Kong Ltd.**  
 19th Floor, Straight Block,  
 Ocean Centre, 5 Canton Rd.  
 Tsimshatsui, Kowloon  
 Hong Kong  
 Tel: (852) 2737-1600  
 Fax: (852) 2736-9960

**National Semiconductor Japan Ltd.**  
 Tel: 81-043-299-2309  
 Fax: 81-043-299-2408

National does not assume any responsibility for use of any circuitry described, no circuit patent licenses are implied and National reserves the right at any time without notice to change said circuitry and specifications.