

# DATA SHEET

For a complete data sheet, please also download:

- The IC04 LOCMOS HE4000B Logic Family Specifications HEF, HEC
- The IC04 LOCMOS HE4000B Logic Package Outlines/Information HEF, HEC

## **HEF4047B**

### **MSI**

## Monostable/astable multivibrator

Product specification  
File under Integrated Circuits, IC04

January 1995

# Monostable/astable multivibrator

**HEF4047B**  
**MSI**

## DESCRIPTION

The HEF4047B consists of a gatable astable multivibrator with logic techniques incorporated to permit positive or negative edge-triggered monostable multivibrator action with retriggering and external counting options.

Inputs include + TRIGGER, - TRIGGER, ASTABLE,  $\overline{\text{ASTABLE}}$ , RETRIGGER and MR (Master Reset). Buffered outputs are O,  $\overline{\text{O}}$  and OSCILLATOR OUTPUT. In all modes of operation an external capacitor ( $C_t$ ) must be connected between  $C_{TC}$  and  $R_{TC}$ , and an external resistor ( $R_t$ ) must be connected between  $R_{TC}$  and  $R_{TC}$  (continued on next page).

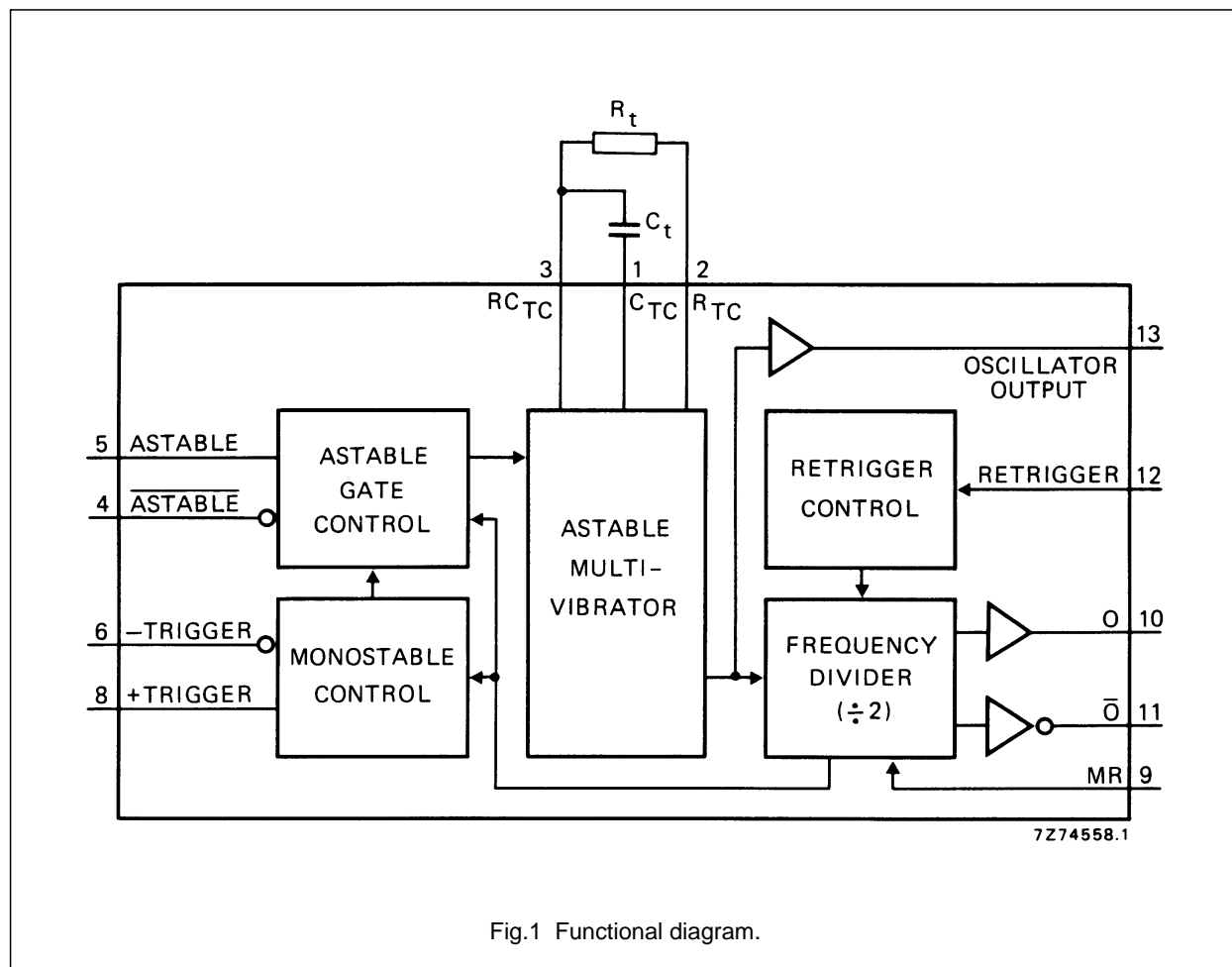

Fig.1 Functional diagram.

## FAMILY DATA, I<sub>DD</sub> LIMITS category MSI

See Family Specifications

## Monostable/astable multivibrator

# HEF4047B MSI

Astable operation is enabled by a HIGH level on the  $\overline{\text{ASTABLE}}$  input. The period of the square wave at O and  $\overline{\text{O}}$  outputs is a function of the external components employed. 'True' input pulses on the  $\overline{\text{ASTABLE}}$  or 'complement' pulses on the  $\overline{\text{ASTABLE}}$  input, allow the circuit to be used as a gatable multivibrator. The OSCILLATOR OUTPUT period will be half of the O output in the astable mode. However, a 50% duty factor is not guaranteed at this output.

In the monostable mode, positive edge-triggering is accomplished by applying a leading-edge pulse to the + TRIGGER input and a LOW level to the - TRIGGER input. For negative edge-triggering, a trailing-edge pulse is applied to the - TRIGGER and a HIGH level to the + TRIGGER. Input pulses may be of any duration relative to the output pulse. The multivibrator can be retriggered (on the leading-edge only) by applying a common pulse to both the RETRIGGER and + TRIGGER inputs. In this mode the output pulse remains HIGH as long as the input pulse period is shorter than the period determined by the RC components.

An external count down option can be implemented by coupling O to an external 'N' counter and resetting the counter with the trigger pulse. The counter output pulse is fed back to the  $\overline{\text{ASTABLE}}$  input and has a duration equal to N times the period of the multivibrator. A HIGH level on the MR input assures no output pulse during an ON-power condition. This input can also be activated to terminate the output pulse at any time. In the monostable mode, a HIGH level or power-ON reset pulse must be applied to MR, whenever  $V_{\text{DD}}$  is applied.

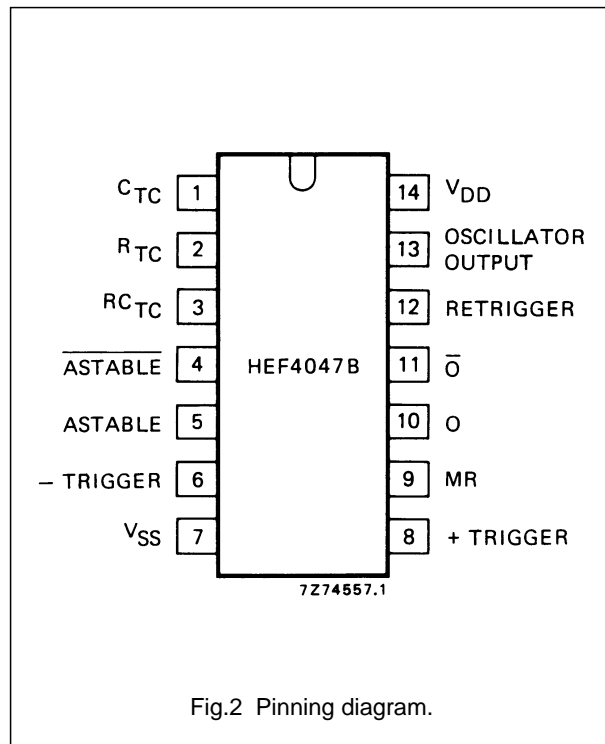

- HEF4047BP(N): 14-lead DIL; plastic (SOT27-1)  
 HEF4047BD(F): 14-lead DIL; ceramic (cerdip) (SOT73)  
 HEF4047BT(D): 14-lead SO; plastic (SOT108-1)  
 ( ): Package Designator North America

Monostable/astable multivibrator

HEF4047B  
MSI

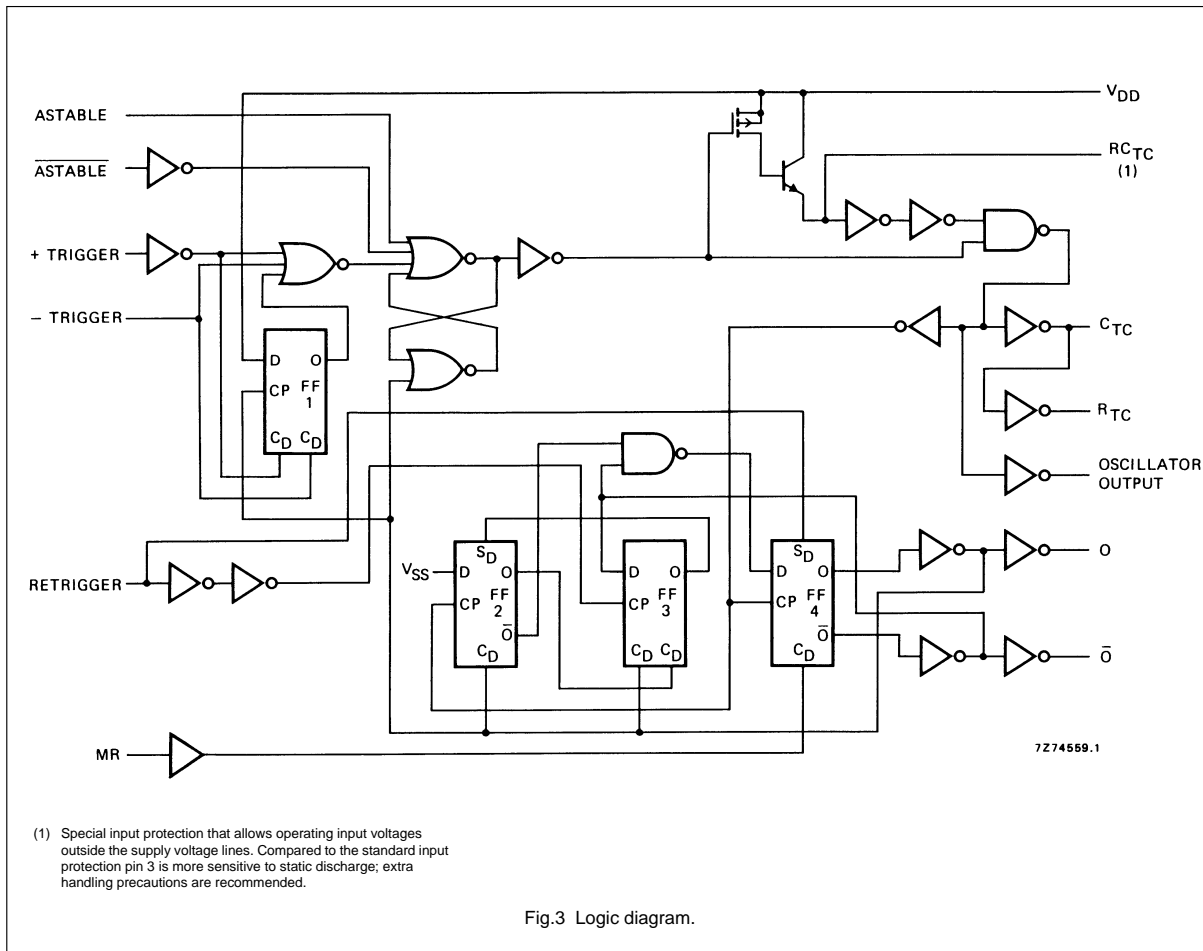

Fig.3 Logic diagram.

(1) Special input protection that allows operating input voltages outside the supply voltage lines. Compared to the standard input protection pin 3 is more sensitive to static discharge; extra handling precautions are recommended.

## Monostable/astable multivibrator

HEF4047B  
MSI

## FUNCTIONAL CONNECTIONS

| FUNCTION                           | PINS CONNECTED TO |                   |             | OUTPUT PULSE FROM PINS | OUTPUT PERIOD OR PULSE WIDTH                                      |
|------------------------------------|-------------------|-------------------|-------------|------------------------|---|
|                                    | V <sub>DD</sub>   | V <sub>SS</sub>   | INPUT PULSE |                        |   |
| <b>astable multivibrator</b>       |                   |                   |             |                        |   |
| free running                       | 4, 5, 6, 14       | 7, 8, 9, 12       | –           | 10, 11, 13             | at pins 10, 11:   |
| true gating                        | 4, 6, 14          | 7, 8, 9, 12       | 5           | 10, 11, 13             | t <sub>A</sub> = 4,40 R <sub>t</sub> C <sub>t</sub>               |
| complement gating                  | 6, 14             | 5, 7, 8, 9, 12    | 4           | 10, 11, 13             | at pin 13:<br>t <sub>A</sub> = 2,20 R <sub>t</sub> C <sub>t</sub> |
| <b>monostable multivibrator</b>    |                   |                   |             |                        |   |
| pos. edge-triggering               | 4, 14             | 5, 6, 7, 9, 12    | 8           | 10, 11                 |   |
| neg. edge-triggering               | 4, 8, 14          | 5, 7, 9, 12       | 6           | 10, 11                 | at pins 10, 11:   |
| retriggerable                      | 4, 14             | 5, 6, 7, 9        | 8, 12       | 10, 11                 | t <sub>M</sub> = 2,48 R <sub>t</sub> C <sub>t</sub>               |
| external count down <sup>(1)</sup> | 14                | 5, 6, 7, 8, 9, 12 | –           | 10, 11                 |   |

## Notes

1. Input pulse to RESET of external counting chip; external counting chip output to pin 4.
2. In all cases, external resistor between pins 2 and 3, external capacitor between pins 1 and 3.

## DC CHARACTERISTICS

V<sub>SS</sub> = 0 V; inputs at V<sub>SS</sub> or V<sub>DD</sub>

|  | V <sub>DD</sub><br>V | SYMBOL         | T <sub>amb</sub> (°C) |             |             |             |    |  |
|--|----------------------|----------------|-----------------------|-------------|-------------|-------------|----|--|
|  |                      |                | –40<br>MAX.           | +25<br>MIN. | +85<br>MAX. | +85<br>MAX. |    |  |
| Leakage current<br>pin 3; output<br>transistor OFF | 15                   | I <sub>3</sub> | 0,3                   | –           | 0,3         | 1           | μA | pin 3 at<br>V <sub>DD</sub> or V <sub>SS</sub> |

## Monostable/astable multivibrator

HEF4047B  
MSI**AC CHARACTERISTICS** $V_{SS} = 0\text{ V}$ ;  $T_{amb} = 25\text{ °C}$ ;  $C_L = 50\text{ pF}$ ; input transition times  $\leq 20\text{ ns}$ 

|   | $V_{DD}$<br>V | SYMBOL    | MIN. | TYP. | MAX. | TYPICAL EXTRAPOLATION<br>FORMULA |
|---|---------------|-----------|------|------|------|----------------------------------|
| Propagation delays  |               |           |      |      |      |                                  |
| ASTABLE, $\overline{\text{ASTABLE}} \rightarrow \text{OSC. OUTPUT}$<br>HIGH to LOW            | 5             |           |      | 95   | 190  | 68 ns + (0,55 ns/pF) $C_L$       |
|   | 10            | $t_{PHL}$ |      | 45   | 90   | 43 ns + (0,23 ns/pF) $C_L$       |
|   | 15            |           |      | 30   | 60   | 22 ns + (0,16 ns/pF) $C_L$       |
| LOW to HIGH   | 5             |           |      | 85   | 170  | 58 ns + (0,55 ns/pF) $C_L$       |
|   | 10            | $t_{PLH}$ |      | 40   | 80   | 29 ns + (0,23 ns/pF) $C_L$       |
|   | 15            |           |      | 30   | 60   | 22 ns + (0,16 ns/pF) $C_L$       |
| ASTABLE, $\overline{\text{ASTABLE}} \rightarrow \text{O}, \overline{\text{O}}$<br>HIGH to LOW | 5             |           |      | 150  | 300  | 123 ns + (0,55 ns/pF) $C_L$      |
|   | 10            | $t_{PHL}$ |      | 65   | 130  | 54 ns + (0,23 ns/pF) $C_L$       |
|   | 15            |           |      | 50   | 100  | 42 ns + (0,16 ns/pF) $C_L$       |
| LOW to HIGH   | 5             |           |      | 130  | 260  | 103 ns + (0,55 ns/pF) $C_L$      |
|   | 10            | $t_{PLH}$ |      | 60   | 120  | 49 ns + (0,23 ns/pF) $C_L$       |
|   | 15            |           |      | 45   | 90   | 37 ns + (0,16 ns/pF) $C_L$       |
| +/- TRIGGER $\rightarrow \text{O}, \overline{\text{O}}$<br>HIGH to LOW                        | 5             |           |      | 160  | 320  | 133 ns + (0,55 ns/pF) $C_L$      |
|   | 10            | $t_{PHL}$ |      | 65   | 130  | 54 ns + (0,23 ns/pF) $C_L$       |
|   | 15            |           |      | 50   | 100  | 42 ns + (0,16 ns/pF) $C_L$       |
| LOW to HIGH   | 5             |           |      | 155  | 310  | 128 ns + (0,55 ns/pF) $C_L$      |
|   | 10            | $t_{PLH}$ |      | 65   | 130  | 54 ns + (0,23 ns/pF) $C_L$       |
|   | 15            |           |      | 50   | 100  | 42 ns + (0,16 ns/pF) $C_L$       |
| + TRIGGER, RETRIGGER $\rightarrow \overline{\text{O}}$<br>HIGH to LOW                         | 5             |           |      | 65   | 130  | 38 ns + (0,55 ns/pF) $C_L$       |
|   | 10            | $t_{PHL}$ |      | 30   | 60   | 19 ns + (0,23 ns/pF) $C_L$       |
|   | 15            |           |      | 25   | 50   | 17 ns + (0,16 ns/pF) $C_L$       |
| + TRIGGER, RETRIGGER $\rightarrow \text{O}$<br>LOW to HIGH                                    | 5             |           |      | 95   | 190  | 68 ns + (0,55 ns/pF) $C_L$       |
|   | 10            | $t_{PLH}$ |      | 40   | 80   | 29 ns + (0,23 ns/pF) $C_L$       |
|   | 15            |           |      | 30   | 60   | 22 ns + (0,16 ns/pF) $C_L$       |
| MR $\rightarrow \text{O}$<br>HIGH to LOW  | 5             |           |      | 100  | 200  | 83 ns + (0,55 ns/pF) $C_L$       |
|   | 10            | $t_{PHL}$ |      | 45   | 90   | 34 ns + (0,23 ns/pF) $C_L$       |
|   | 15            |           |      | 35   | 70   | 27 ns + (0,16 ns/pF) $C_L$       |
| MR $\rightarrow \overline{\text{O}}$<br>LOW to HIGH   | 5             |           |      | 100  | 200  | 83 ns + (0,55 ns/pF) $C_L$       |
|   | 10            | $t_{PLH}$ |      | 45   | 90   | 34 ns + (0,23 ns/pF) $C_L$       |
|   | 15            |           |      | 35   | 70   | 27 ns + (0,16 ns/pF) $C_L$       |
| Output transition times   |               |           |      |      |      |                                  |
| HIGH to LOW   | 5             |           |      | 60   | 120  | 10 ns + (1,0 ns/pF) $C_L$        |
|   | 10            | $t_{THL}$ |      | 30   | 60   | 9 ns + (0,42 ns/pF) $C_L$        |
|   | 15            |           |      | 20   | 40   | 6 ns + (0,28 ns/pF) $C_L$        |
| LOW to HIGH   | 5             |           |      | 60   | 120  | 10 ns + (1,0 ns/pF) $C_L$        |
|   | 10            | $t_{TLH}$ |      | 30   | 60   | 9 ns + (0,42 ns/pF) $C_L$        |
|   | 15            |           |      | 20   | 40   | 6 ns + (0,28 ns/pF) $C_L$        |

## Monostable/astable multivibrator

HEF4047B  
MSI

|  | $V_{DD}$<br>V | SYMBOL     | MIN. | TYP. | MAX. | TYPICAL EXTRAPOLATION<br>FORMULA |
|--|---------------|------------|------|------|------|----------------------------------|
| Minimum MR pulse<br>width; HIGH                      | 5             | $t_{WMRH}$ | 60   | 30   |      |                                  |
|  | 10            |            | 30   | 15   |      |                                  |
|  | 15            |            | 20   | 10   |      |                                  |
| Minimum input<br>pulse width; any<br>input except MR | 5             | $t_W$      | 220  | 110  |      |                                  |
|  | 10            |            | 100  | 50   |      |                                  |
|  | 15            |            | 70   | 35   |      |                                  |

**APPLICATION INFORMATION****General features:**

- Monostable (one-shot) or astable (free-running) operation
- True and complemented buffered outputs
- Only one external R and C required

**Monostable multivibrator features:**

- Positive- or negative-edge triggering
- Output pulse width independent of trigger pulse duration
- Retriggerable option for pulse-width expansion
- Long pulse width possible using small RC components by means of external counter provision
- Fast recovery time essentially independent of pulse width
- Pulse-width accuracy maintained at duty cycles approaching 100%

**Astable multivibrator features:**

- Free-running or gatable operating modes
- 50% duty cycle
- Oscillator output available

## Monostable/astable multivibrator

HEF4047B  
MSI

## 1. Astable mode design information

## a. Unit-to-unit transfer-voltage variations

The following analysis presents worst-case variations from unit-to-unit as a function of transfer-voltage ( $V_{TR}$ ) shift for free running (astable) operation.

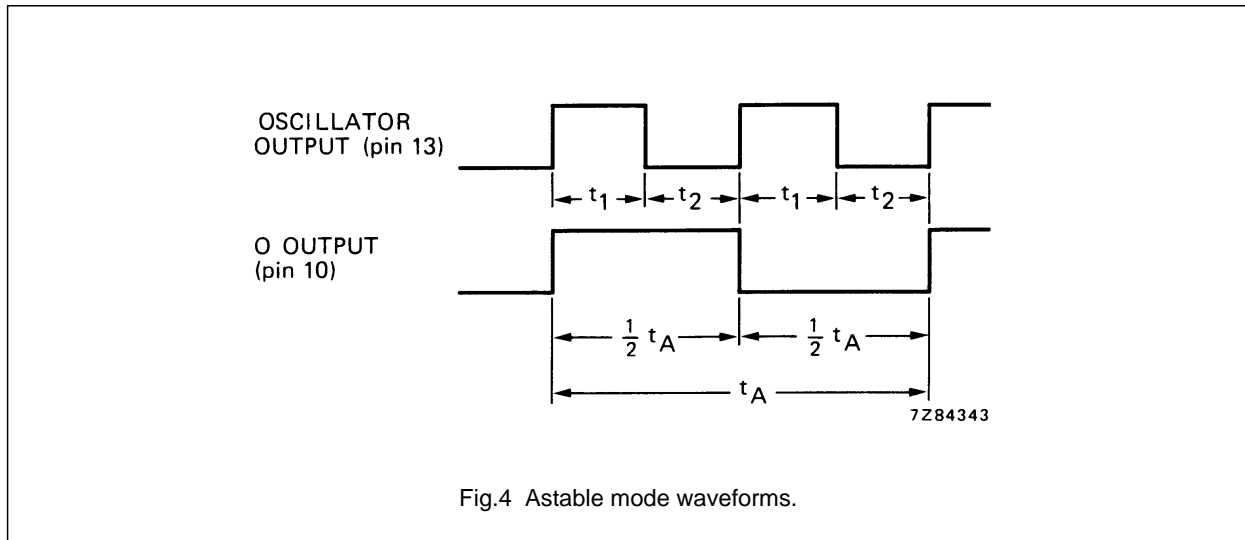

Fig.4 Astable mode waveforms.

$$t_1 = -R_t C_t \ln \frac{V_{TR}}{V_{DD} + V_{TR}}$$

$$t_2 = -R_t C_t \ln \frac{V_{DD} - V_{TR}}{2V_{DD} - V_{TR}}$$

$$t_A = 2(t_1 + t_2) = -2R_t C_t \ln \frac{(V_{TR})(V_{DD} - V_{TR})}{(V_{DD} + V_{TR})(2V_{DD} - V_{TR})}, \text{ where } t_A = \text{Astable mode pulse width.}$$

Values for  $t_A$  are:

|                                       |                                  |                      |
|---------------------------------------|----------------------------------|----------------------|
|                                       | typ. : $V_{TR} = 0,5 V_{DD}$ ;   | $t_A = 4,40 R_t C_t$ |
| $V_{DD} = 5 \text{ or } 10 \text{ V}$ | min. : $V_{TR} = 0,3 V_{DD}$ ;   | $t_A = 4,71 R_t C_t$ |
|                                       | max. : $V_{TR} = 0,7 V_{DD}$ ;   | $t_A = 4,71 R_t C_t$ |
| $V_{DD} = 15 \text{ V}$               | min. : $V_{TR} = 4 \text{ V}$ ;  | $t_A = 4,84 R_t C_t$ |
|                                       | max. : $V_{TR} = 11 \text{ V}$ ; | $t_A = 4,84 R_t C_t$ |

thus if  $t_A = 4,40 R_t C_t$  is used, the maximum variation will be (+ 7,0%; -0,0%) at 10 V.



## Monostable/astable multivibrator

HEF4047B  
MSI*b. Variations due to changes in  $V_{DD}$* 

In addition to variations from unit-to-unit, the astable period may vary as a function of frequency with respect to  $V_{DD}$ . Typical variations are presented graphically in Figs 5 and 6 with 10 V as a reference.

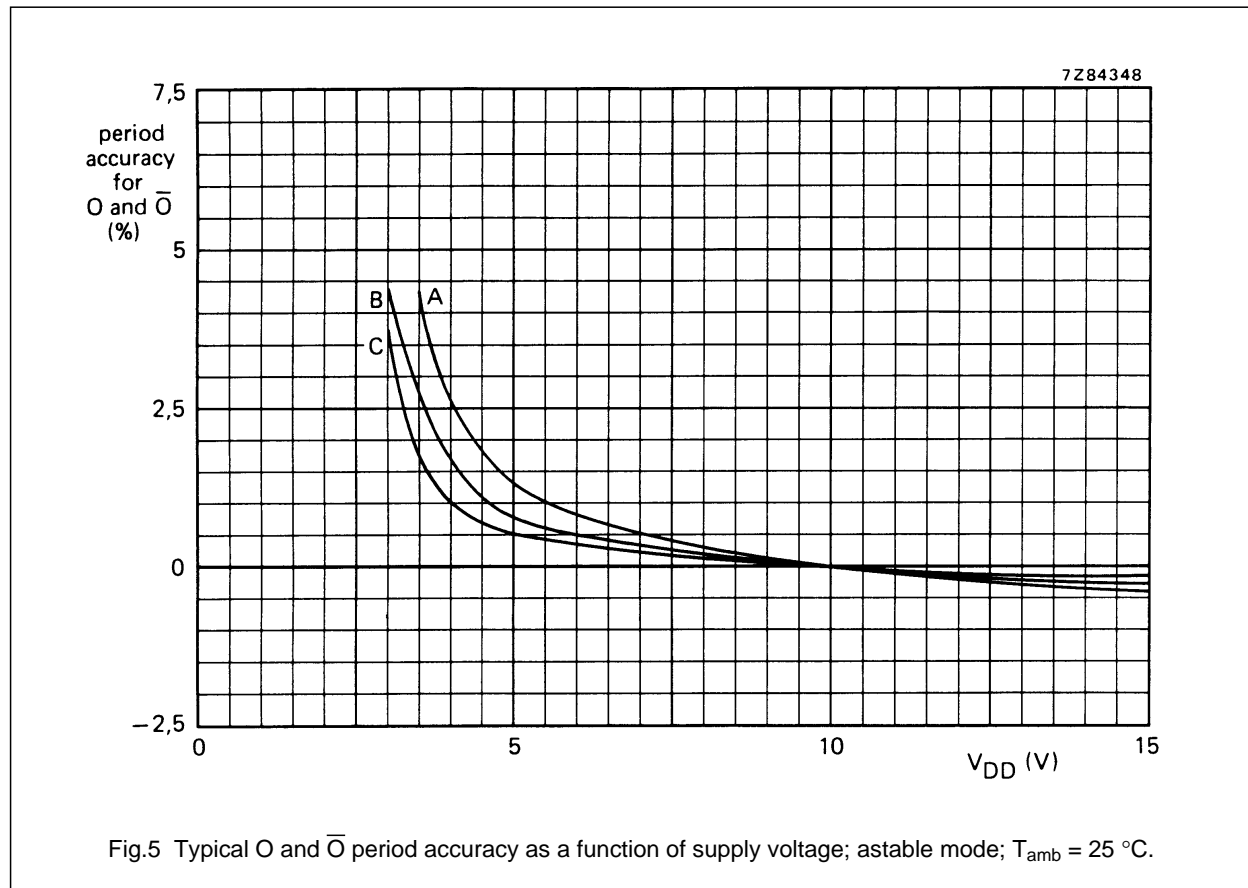

| CURVE | $f_o$<br>kHz | $C_t$<br>pF | $R_t$<br>k $\Omega$ |
|-------|--------------|-------------|---------------------|
| A     | 10           | 100         | 220                 |
| B     | 5            | 100         | 470                 |
| C     | 1            | 1000        | 220                 |

Monostable/astable multivibrator

HEF4047B  
MSI

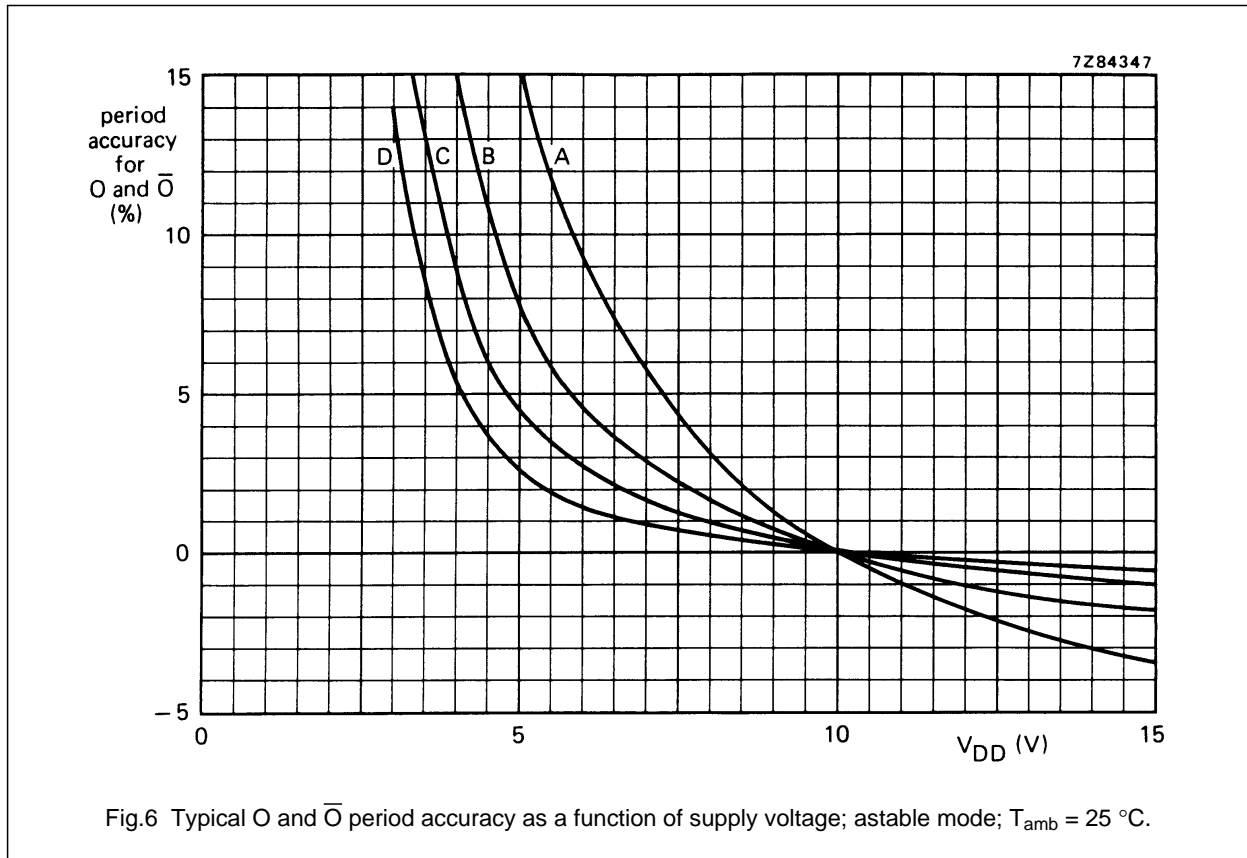

| CURVE | $f_o$<br>kHz | $C_t$<br>pF | $R_t$<br>k $\Omega$ |
|-------|--------------|-------------|---------------------|
| A     | 500          | 10          | 47                  |
| B     | 225          | 100         | 10                  |
| C     | 100          | 100         | 22                  |
| D     | 50           | 100         | 47                  |

## Monostable/astable multivibrator

HEF4047B  
MSI

## 2. Monostable mode design information

The following analysis presents worst case variations from unit-to-unit as a function of transfer-voltage ( $V_{TR}$ ) shift for one-shot (monostable) operation.

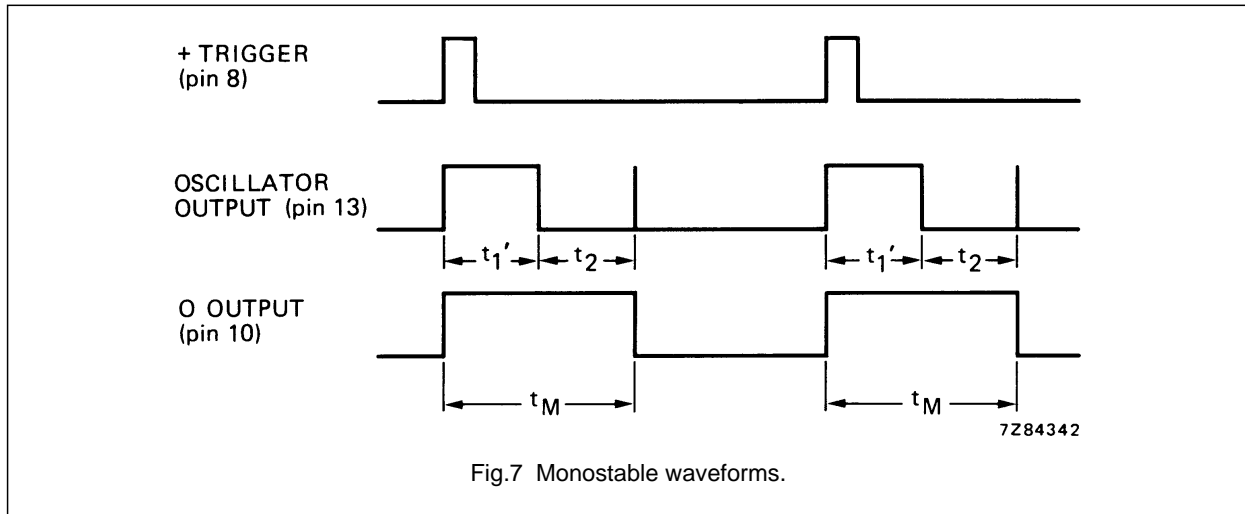

Fig.7 Monostable waveforms.

$$t_1' = -R_t C_t \ln \frac{V_{TR}}{2V_{DD}}$$

$$t_M = (t_1' + t_2)$$

$$t_M = -R_t C_t \ln \frac{(V_{TR})(V_{DD} - V_{TR})}{(2V_{DD} - V_{TR})(2V_{DD})}, \text{ where } t_M = \text{Monostable mode pulse width.}$$

Values for  $t_M$  are:

|                                       |  |
|---------------------------------------|--|
|                                       | typ. : $V_{TR} = 0,5 V_{DD}$ ; $t_M = 2,48 R_t C_t$  |
| $V_{DD} = 5 \text{ to } 10 \text{ V}$ | min. : $V_{TR} = 0,3 V_{DD}$ ; $t_M = 2,78 R_t C_t$  |
|                                       | max.: $V_{TR} = 0,7 V_{DD}$ ; $t_M = 2,52 R_t C_t$   |
| $V_{DD} = 15 \text{ V}$               | min. : $V_{TR} = 4 \text{ V}$ ; $t_M = 2,88 R_t C_t$ |
|                                       | max.: $V_{TR} = 11 \text{ V}$ ; $t_M = 2,56 R_t C_t$ |

**Note**

1. In the astable mode, the first positive half cycle has a duration of  $t_M$ ; succeeding durations are  $\frac{1}{2} t_A$ .

thus if  $t_M = 2,48 R_t C_t$  is used, the maximum variation will be (+ 12%; -0,0%) at 10 V.

## Monostable/astable multivibrator

HEF4047B  
MSI

## 3. Retrigger mode operation

The HEF4047B can be used in the retrigger mode to extend the output pulse duration, or to compare the frequency of an input signal with that of the internal oscillator. In the retrigger mode the input pulse is applied to pins 8 and 12, and the output is taken from pin 10 or 11. Normal monostable action is obtained when one retrigger pulse is applied (Fig.8). Extended pulse duration is obtained when more than one pulse is applied. For two input pulses,  $t_{RE} = t_1' + t_1 + 2t_2$ . For more than two pulses,  $t_{RE}$  (output O), terminates at some variable time,  $t_D$ , after the termination of the last retrigger pulse;  $t_D$  is variable because  $t_{RE}$  (output O) terminates after the second positive edge of the oscillator output appears at flip-flop 4.

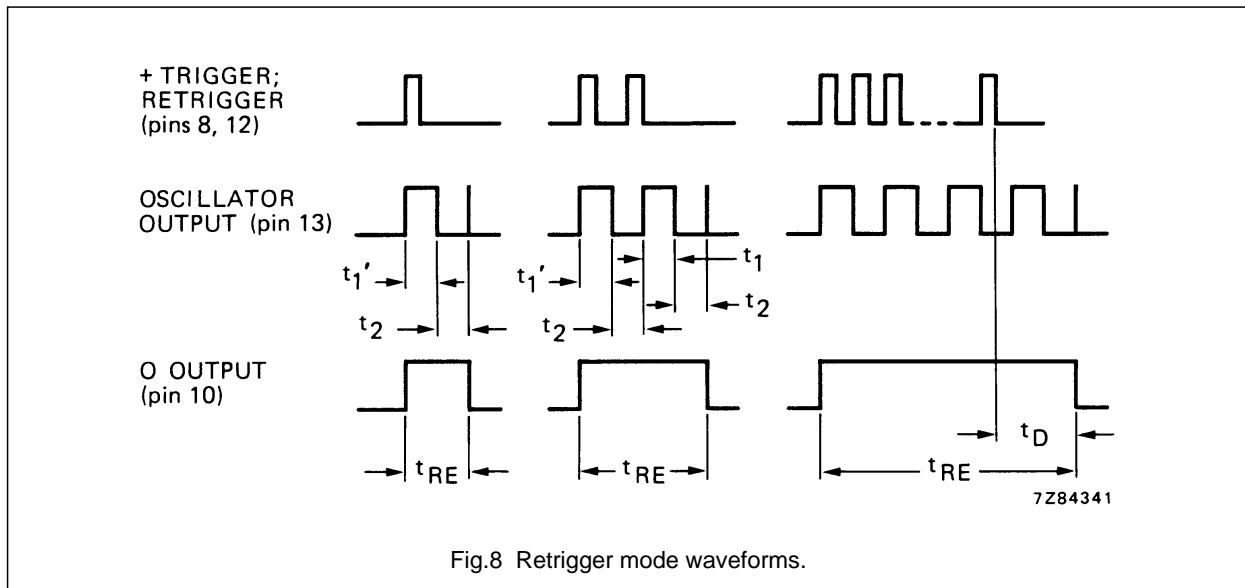

Fig.8 Retrigger mode waveforms.

## 4. External counter option

Time  $t_M$  can be extended by any amount with the use of external counting circuitry. Advantages include digitally controlled pulse duration, small timing capacitors for long time periods, and extremely fast recovery time. A typical implementation is shown in Fig.9.

The pulse duration at the output is:  $t_{ext} = (N - 1) (t_A) + (t_M + 1/2 t_A)$

Where  $t_{ext}$  = pulse duration of the circuitry, and N is the number of counts used.

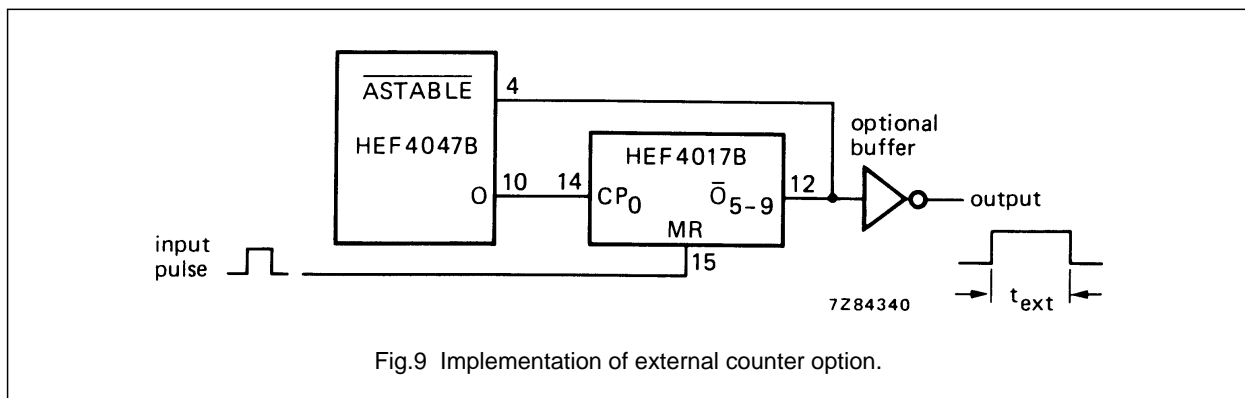

Fig.9 Implementation of external counter option.

---

**Monostable/astable multivibrator**
**HEF4047B**  
**MSI**

---

**5. Timing component limitations**

The capacitor used in the circuit should be non-polarized and have low leakage (i.e. the parallel resistance of the capacitor should be an order of magnitude greater than the external resistor used).

There is no upper or lower limit for either  $R_t$  or  $C_t$  value to maintain oscillation.

However, in consideration of accuracy,  $C_t$  must be much larger than the inherent stray capacitance in the system (unless this capacitance can be measured and taken into account).

$R_t$  must be much larger than the LOCMOS 'ON' resistance in series with it, which typically is hundreds of ohms.

The recommended values for  $R_t$  and  $C_t$  to maintain agreement with previously calculated formulae without trimming should be:

$$C_t \geq 100 \text{ pF, up to any practical value,}$$

$$10 \text{ k}\Omega \leq R_t \leq 1 \text{ M}\Omega.$$

**6. Power consumption**

In the standby mode (monostable or astable), power dissipation will be a function of leakage current in the circuit.

For dynamic operation, the power needed to charge the external timing capacitor  $C_t$  is given by the following formulae:

---

|               |  |
|---------------|--|
| Astable mode: | $P = 2 C_t V^2 f$ (f at output pin 13)         |
|               | $P = 4 C_t V^2 f$ (f at output pins 10 and 11) |

---

|                  |   |
|------------------|---|
| Monostable mode: | $P = \frac{(2,9 C_t V^2)(\text{duty cycle})}{T}$ (f at output pins 10 and 11) |
|------------------|---|

---

Because the power dissipation does not depend on  $R_t$ , a design for minimum power dissipation would be a small value of  $C_t$ . The value of R would depend on the desired period (within the limitations discussed previously).

Typical power consumption in astable mode is shown in Figs 10, 11 and 12.

Monostable/astable multivibrator

HEF4047B  
MSI

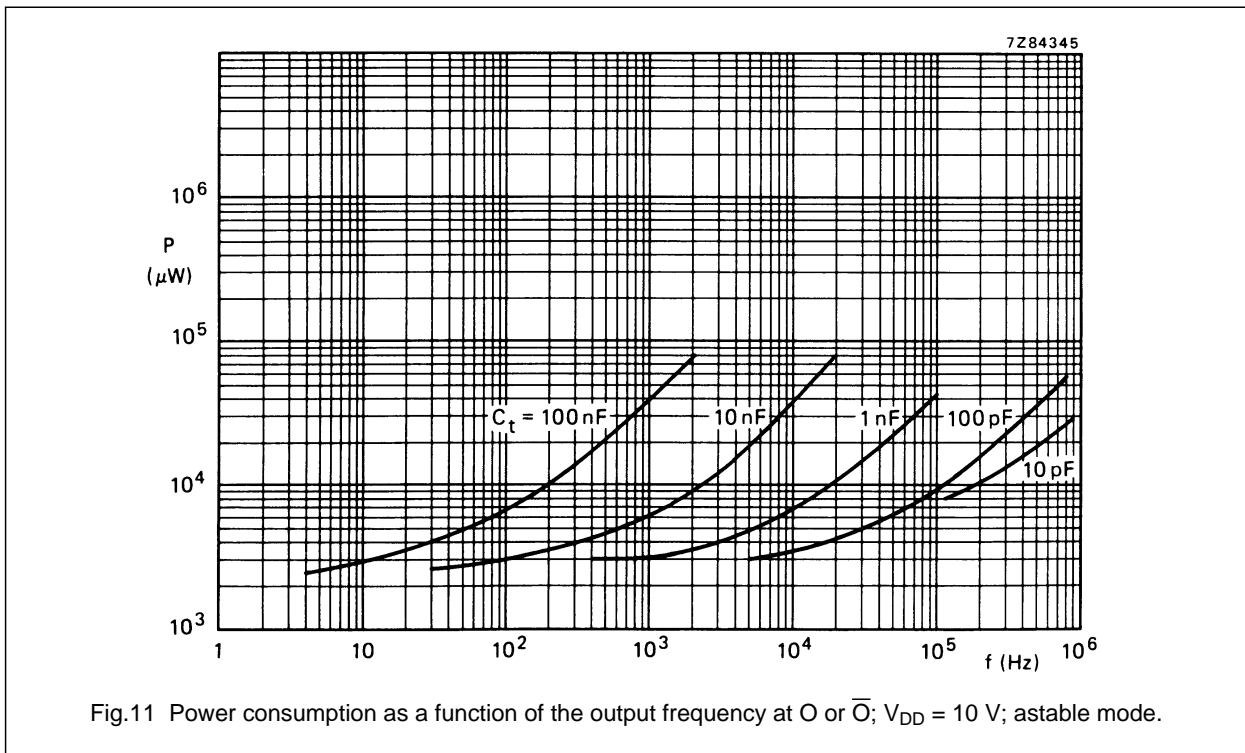
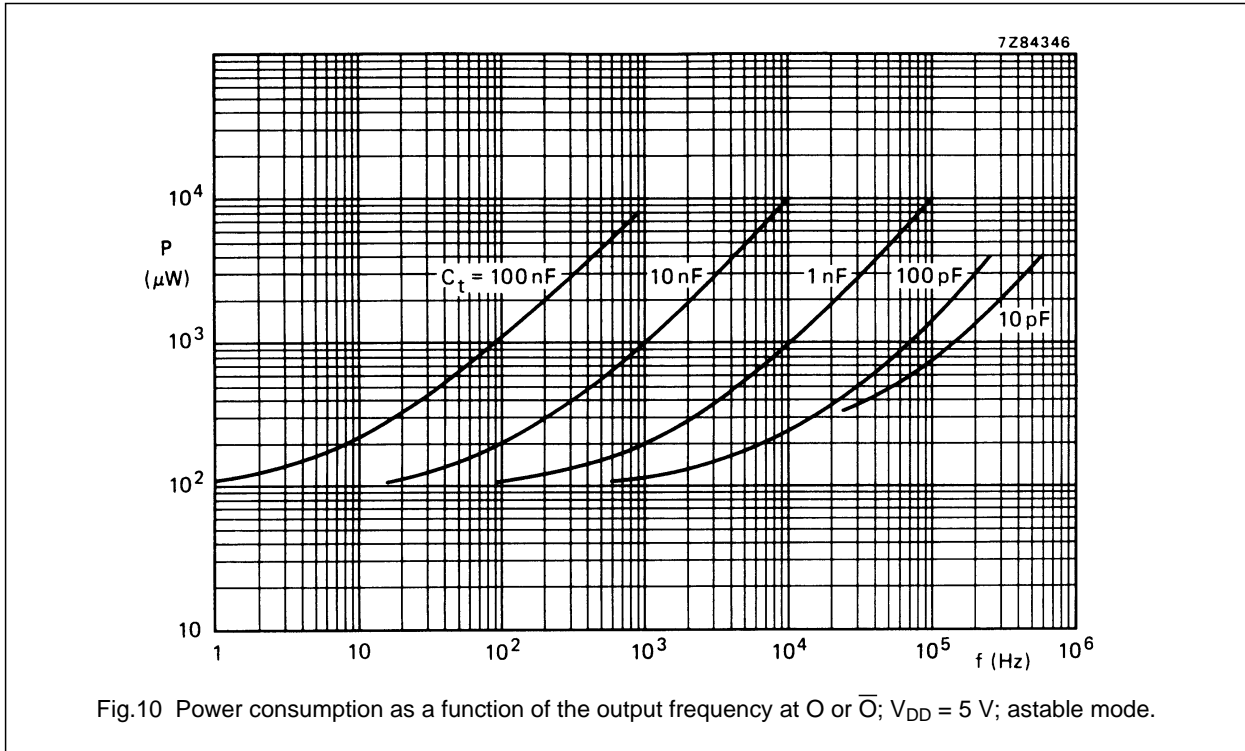

Monostable/astable multivibrator

HEF4047B  
MSI

