

INSULATED GATE BIPOLAR TRANSISTOR WITH  
ULTRAFAST SOFT RECOVERY DIODE

# IRGIB7B60KD

### Features

- Low VCE (on) Non Punch Through IGBT Technology.
- 10µs Short Circuit Capability.
- Square RBSOA.
- Positive VCE (on) Temperature Coefficient.
- Maximum Junction Temperature rated at 175°C.

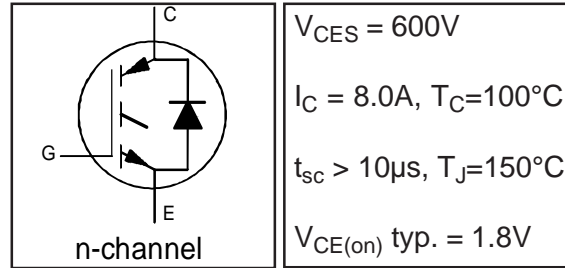

### Benefits

- Benchmark Efficiency for Motor Control.
- Rugged Transient Performance.
- Low EMI.
- Excellent Current Sharing in Parallel Operation.

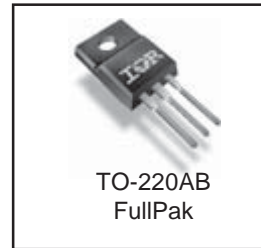

### Absolute Maximum Ratings

	Parameter	Max.	Units
$V_{CES}$	Collector-to-Emitter Voltage	600	V
$I_C @ T_C = 25^\circ C$	Continuous Collector Current	12	A
$I_C @ T_C = 100^\circ C$	Continuous Collector Current	8.0	
$I_{CM}$	Pulse Collector Current (Ref.Fig.C.T.5)	24	
$I_{LM}$	Clamped Inductive Load current ①	24	
$I_F @ T_C = 25^\circ C$	Diode Continuous Forward Current	9.0	
$I_F @ T_C = 100^\circ C$	Diode Continuous Forward Current	6.0	
$I_{FM}$	Diode Maximum Forward Current	18	
$V_{ISOL}$	RMS Isolation Voltage, Terminal to Case, t=1 min.	2500	V
$V_{GE}$	Gate-to-Emitter Voltage	±20	
$P_D @ T_C = 25^\circ C$	Maximum Power Dissipation	39	W
$P_D @ T_C = 100^\circ C$	Maximum Power Dissipation	20	
$T_J$	Operating Junction and	-55 to +175	°C
$T_{STG}$	Storage Temperature Range		
	Soldering Temperature, for 10 sec.	300 (0.063 in. (1.6mm) from case)	
	Mounting Torque, 6-32 or M3 Screw	10 lbf-in (1.1 N-m)	

### Thermal / Mechanical Characteristics

	Parameter	Min.	Typ.	Max.	Units
$R_{\theta JC}$	Junction-to-Case- IGBT	—	—	3.8	°C/W
$R_{\theta JC}$	Junction-to-Case- Diode	—	—	6.0	
$R_{\theta CS}$	Case-to-Sink, flat, greased surface	—	0.50	—	
$R_{\theta JA}$	Junction-to-Ambient, typical socket mount	—	—	62	
Wt	Weight	—	2.0	—	g

# IRGIB7B60KD

International  
**IR** Rectifier

## Electrical Characteristics @ T<sub>J</sub> = 25°C (unless otherwise specified)

	Parameter	Min.	Typ.	Max.	Units	Conditions	Ref.Fig.
V <sub>(BR)CES</sub>	Collector-to-Emitter Breakdown Voltage	600	—	—	V	V <sub>GE</sub> = 0V, I <sub>C</sub> = 500μA	
ΔV <sub>(BR)CES</sub> /ΔT <sub>J</sub>	Temperature Coeff. of Breakdown Voltage	—	0.57	—	V/°C	V <sub>GE</sub> = 0V, I <sub>C</sub> = 1mA (25°C-150°C)	
V <sub>CE(on)</sub>	Collector-to-Emitter Voltage	—	1.8	2.2	V	I <sub>C</sub> = 8.0A, V <sub>GE</sub> = 15V, T <sub>J</sub> = 25°C	5,6,7
		—	2.2	2.5		I <sub>C</sub> = 8.0A, V <sub>GE</sub> = 15V, T <sub>J</sub> = 150°C	9,10,11
		—	2.3	2.5		I <sub>C</sub> = 8.0A, V <sub>GE</sub> = 15V, T <sub>J</sub> = 175°C	
V <sub>GE(th)</sub>	Gate Threshold Voltage	3.5	4.5	5.5	V	V <sub>CE</sub> = V <sub>GE</sub> , I <sub>C</sub> = 250μA	9,10,11
ΔV <sub>GE(th)</sub> /ΔT <sub>J</sub>	Threshold Voltage temp. coefficient	—	-9.5	—	mV/°C	V <sub>CE</sub> = V <sub>GE</sub> , I <sub>C</sub> = 1mA (25°C-150°C)	12
g <sub>fe</sub>	Forward Transconductance	—	3.7	—	S	V <sub>CE</sub> = 50V, I <sub>C</sub> = 8.0A, PW = 80μs	
I <sub>CES</sub>	Zero Gate Voltage Collector Current	—	1.0	150	μA	V <sub>GE</sub> = 0V, V <sub>CE</sub> = 600V	
		—	200	500		V <sub>GE</sub> = 0V, V <sub>CE</sub> = 600V, T <sub>J</sub> = 150°C	
		—	720	1100		V <sub>GE</sub> = 0V, V <sub>CE</sub> = 600V, T <sub>J</sub> = 175°C	
V <sub>FM</sub>	Diode Forward Voltage Drop	—	1.25	1.45	V	I <sub>F</sub> = 5.0A, V <sub>GE</sub> = 0V	8
		—	1.20	1.40		I <sub>F</sub> = 5.0A, T <sub>J</sub> = 150°C, V <sub>GE</sub> = 0V	
		—	1.20	1.30		I <sub>F</sub> = 5.0A, T <sub>J</sub> = 175°C, V <sub>GE</sub> = 0V	
I <sub>GES</sub>	Gate-to-Emitter Leakage Current	—	—	±100	nA	V <sub>GE</sub> = ±20V, V <sub>CE</sub> = 0V	

## Switching Characteristics @ T<sub>J</sub> = 25°C (unless otherwise specified)

	Parameter	Min.	Typ.	Max.	Units	Conditions	Ref.Fig.
Q <sub>g</sub>	Total Gate Charge (turn-on)	—	29	44	nC	I <sub>C</sub> = 8.0A	23
Q <sub>ge</sub>	Gate-to-Emitter Charge (turn-on)	—	3.7	5.6		V <sub>CC</sub> = 400V	CT1
Q <sub>gc</sub>	Gate-to-Collector Charge (turn-on)	—	14	21		V <sub>GE</sub> = 15V	
E <sub>on</sub>	Turn-On Switching Loss	—	160	268	μJ	I <sub>C</sub> = 8.0A, V <sub>CC</sub> = 400V	CT4
E <sub>off</sub>	Turn-Off Switching Loss	—	160	268		V <sub>GE</sub> = 15V, R <sub>G</sub> = 50Ω, L = 1.1mH	
E <sub>tot</sub>	Total Switching Loss	—	320	433		T <sub>J</sub> = 25°C ②	
t <sub>d(on)</sub>	Turn-On delay time	—	23	27	ns	I <sub>C</sub> = 8.0A, V <sub>CC</sub> = 400V	CT4
t <sub>r</sub>	Rise time	—	22	26		V <sub>GE</sub> = 15V, R <sub>G</sub> = 50Ω, L = 1.1mH	
t <sub>d(off)</sub>	Turn-Off delay time	—	140	150		T <sub>J</sub> = 25°C	
t <sub>f</sub>	Fall time	—	32	42			
E <sub>on</sub>	Turn-On Switching Loss	—	220	330		I <sub>C</sub> = 8.0A, V <sub>CC</sub> = 400V	
E <sub>off</sub>	Turn-Off Switching Loss	—	270	381	μJ	V <sub>GE</sub> = 15V, R <sub>G</sub> = 50Ω, L = 1.1mH	13,15
E <sub>tot</sub>	Total Switching Loss	—	490	711		T <sub>J</sub> = 150°C ②	WF1,WF2
t <sub>d(on)</sub>	Turn-On delay time	—	22	27		I <sub>C</sub> = 8.0A, V <sub>CC</sub> = 400V	14,16
t <sub>r</sub>	Rise time	—	21	25	ns	V <sub>GE</sub> = 15V, R <sub>G</sub> = 50Ω, L = 1.1mH	CT4
t <sub>d(off)</sub>	Turn-Off delay time	—	180	198		T <sub>J</sub> = 150°C	WF1
t <sub>f</sub>	Fall time	—	40	56			WF2
L <sub>E</sub>	Internal Emitter Inductance	—	7.5	—	nH	Measured 5mm from package	
C <sub>ies</sub>	Input Capacitance	—	440	660	pF	V <sub>GE</sub> = 0V	22
C <sub>oes</sub>	Output Capacitance	—	38	57		V <sub>CC</sub> = 30V	
C <sub>res</sub>	Reverse Transfer Capacitance	—	16	24		f = 1.0MHz	
RBSOA	Reverse Bias Safe Operating Area	FULL SQUARE				T <sub>J</sub> = 150°C, I <sub>C</sub> = 54A, V <sub>p</sub> = 600V V <sub>CC</sub> =500V, V <sub>GE</sub> = +15V to 0V, R <sub>G</sub> = 50Ω	4 CT2
SCSOA	Short Circuit Safe Operating Area	10	—	—	μs	T <sub>J</sub> = 150°C, V <sub>p</sub> = 600V, R <sub>G</sub> = 100Ω V <sub>CC</sub> =360V, V <sub>GE</sub> = +15V to 0V	CT3 WF4
I <sub>SC (Peak)</sub>	Peak Short Circuit Collector Current	—	70	—	A		WF4
E <sub>rec</sub>	Reverse Recovery Energy of the Diode	—	100	133	μJ	T <sub>J</sub> = 150°C	17,18,19
t <sub>rr</sub>	Diode Reverse Recovery Time	—	95	120	ns	V <sub>CC</sub> = 400V, I <sub>F</sub> = 8.0A, L = 1.07mH	20,21
I <sub>rr</sub>	Peak Reverse Recovery Current	—	13	17	A	V <sub>GE</sub> = 15V, R <sub>G</sub> = 50Ω	CT4,WF3
Q <sub>rr</sub>	Diode Reverse Recovery Charge	—	620	800	nC	di/dt = 500A/μS	

Note ① to ② are on page 12

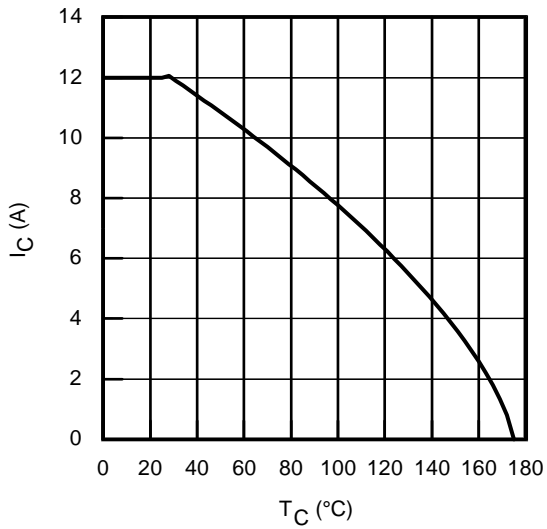

**Fig. 1** - Maximum DC Collector Current vs. Case Temperature

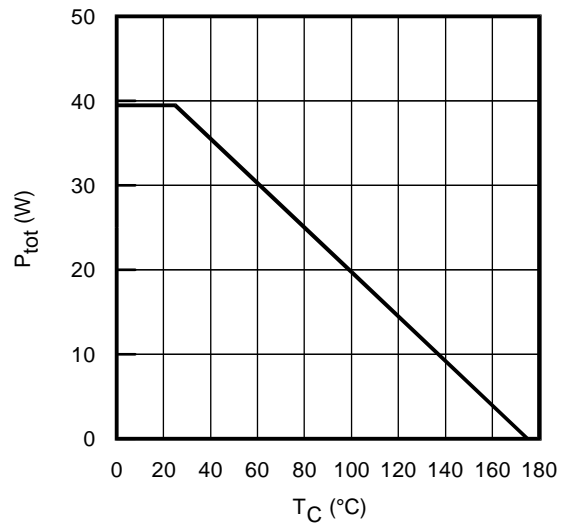

**Fig. 2** - Power Dissipation vs. Case Temperature

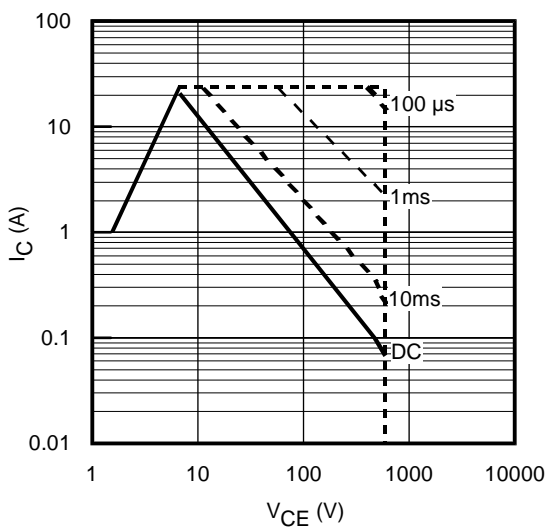

**Fig. 3** - Forward SOA  
 $T_C = 25^{\circ}C$ ;  $T_J \leq 150^{\circ}C$

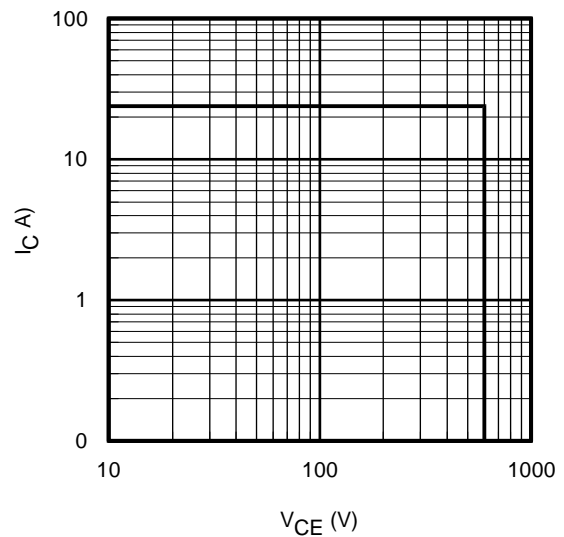

**Fig. 4** - Reverse Bias SOA  
 $T_J = 150^{\circ}C$ ;  $V_{GE} = 15V$

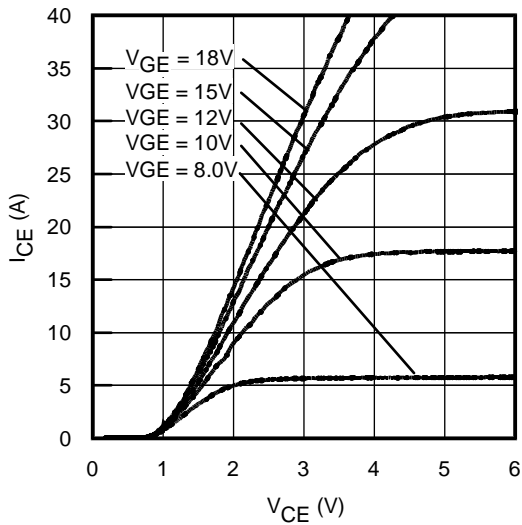

**Fig. 5** - Typ. IGBT Output Characteristics  
 $T_J = -40^\circ\text{C}$ ;  $t_p = 80\mu\text{s}$

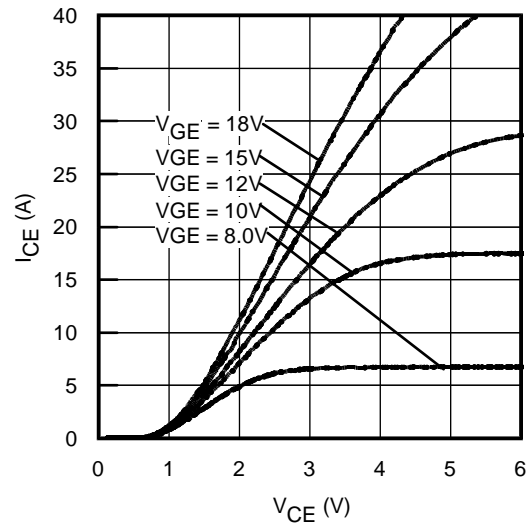

**Fig. 6** - Typ. IGBT Output Characteristics  
 $T_J = 25^\circ\text{C}$ ;  $t_p = 80\mu\text{s}$

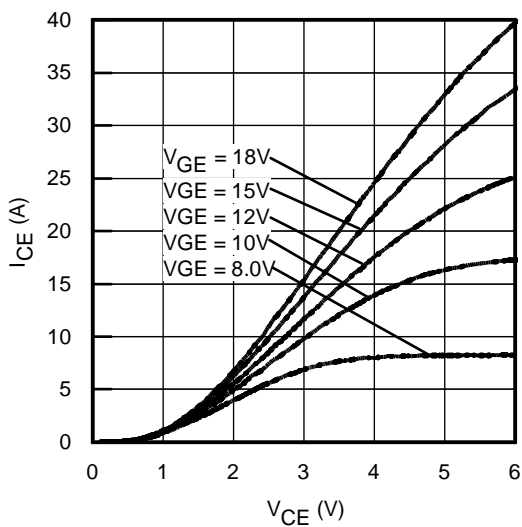

**Fig. 7** - Typ. IGBT Output Characteristics  
 $T_J = 150^\circ\text{C}$ ;  $t_p = 80\mu\text{s}$

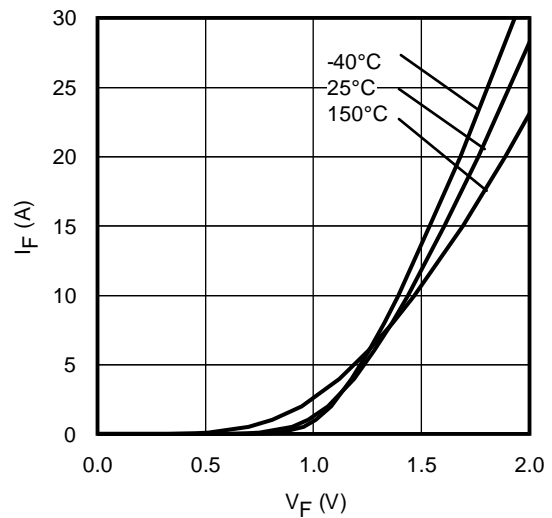

**Fig. 8** - Typ. Diode Forward Characteristics  
 $t_p = 80\mu\text{s}$

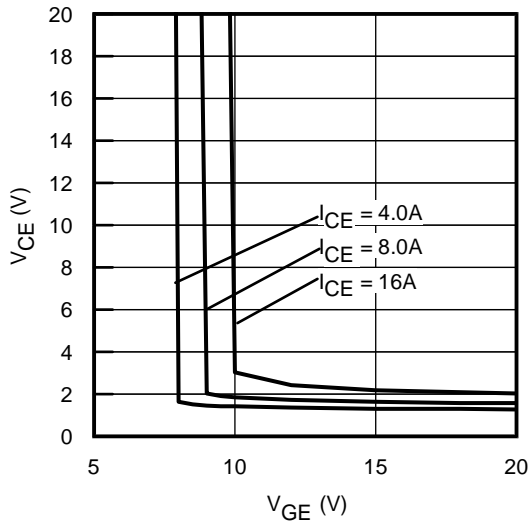

**Fig. 9** - Typical  $V_{CE}$  vs.  $V_{GE}$   
 $T_J = -40^\circ\text{C}$

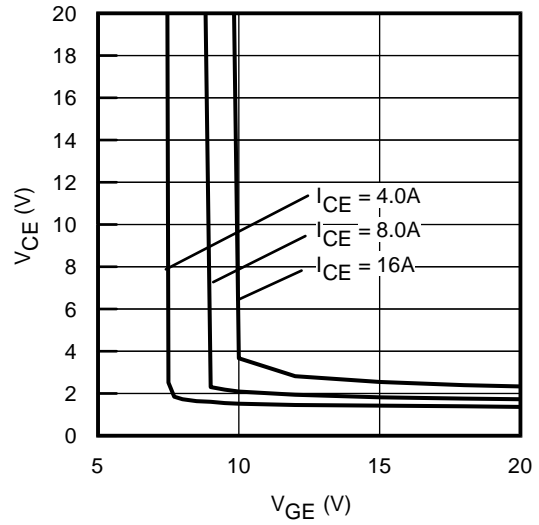

**Fig. 10** - Typical  $V_{CE}$  vs.  $V_{GE}$   
 $T_J = 25^\circ\text{C}$

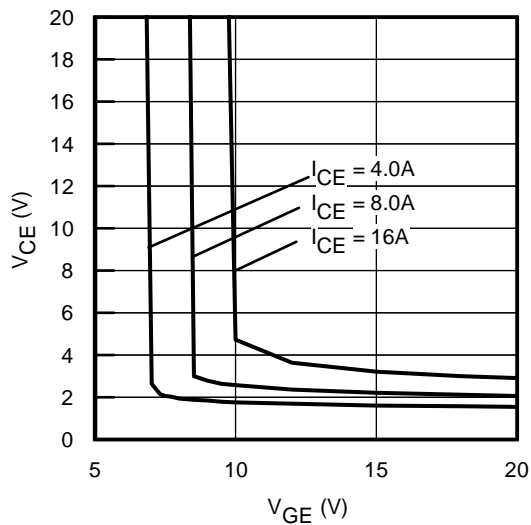

**Fig. 11** - Typical  $V_{CE}$  vs.  $V_{GE}$   
 $T_J = 150^\circ\text{C}$

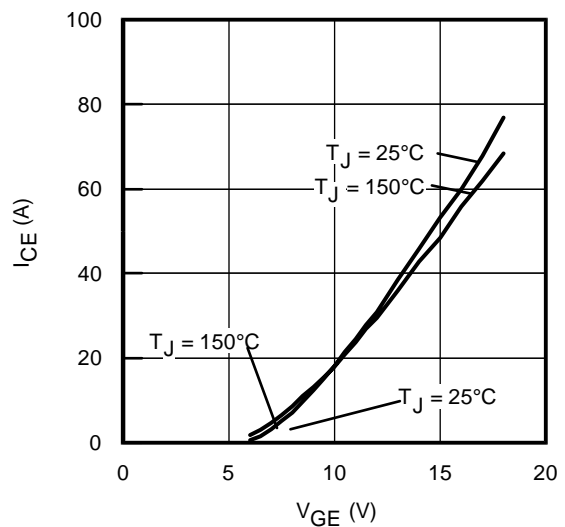

**Fig. 12** - Typ. Transfer Characteristics  
 $V_{CE} = 360\text{V}$ ;  $t_p = 10\mu\text{s}$

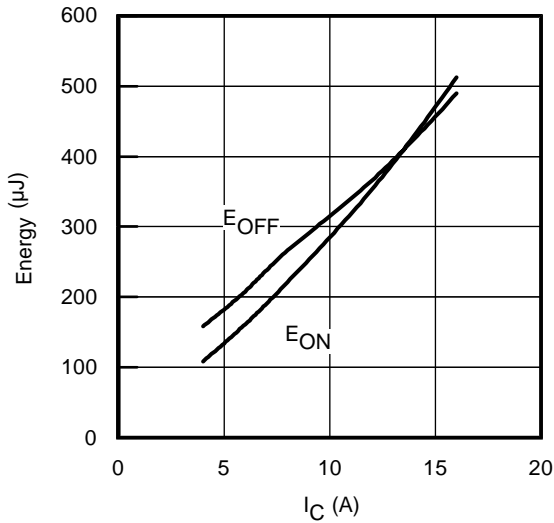

**Fig. 13** - Typ. Energy Loss vs.  $I_C$   
 $T_J = 150^\circ\text{C}$ ;  $L=1.1\text{mH}$ ;  $V_{CE}= 400\text{V}$ ,  
 $R_G= 50\Omega$ ;  $V_{GE}= 15\text{V}$

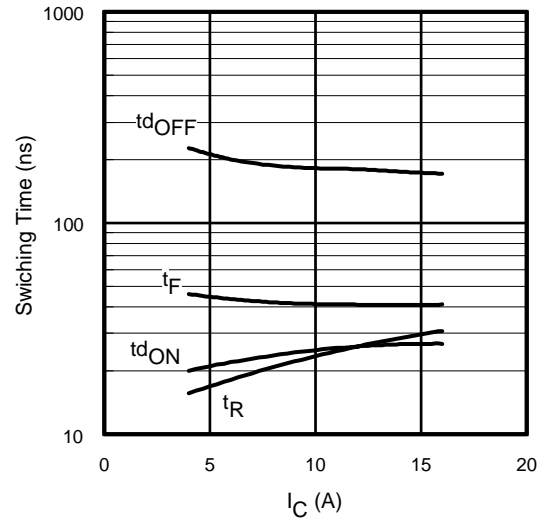

**Fig. 14** - Typ. Switching Time vs.  $I_C$   
 $T_J = 150^\circ\text{C}$ ;  $L=1.1\text{mH}$ ;  $V_{CE}= 400\text{V}$   
 $R_G= 50\Omega$ ;  $V_{GE}= 15\text{V}$

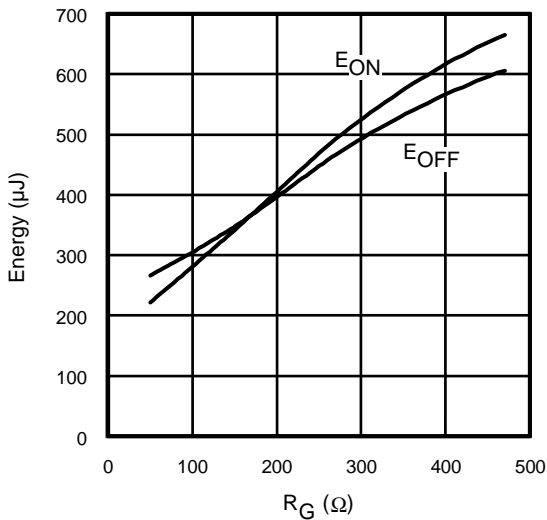

**Fig. 15** - Typ. Energy Loss vs.  $R_G$   
 $T_J = 150^\circ\text{C}$ ;  $L=1.1\text{mH}$ ;  $V_{CE}= 400\text{V}$   
 $I_{CE}= 8.0\text{A}$ ;  $V_{GE}= 15\text{V}$

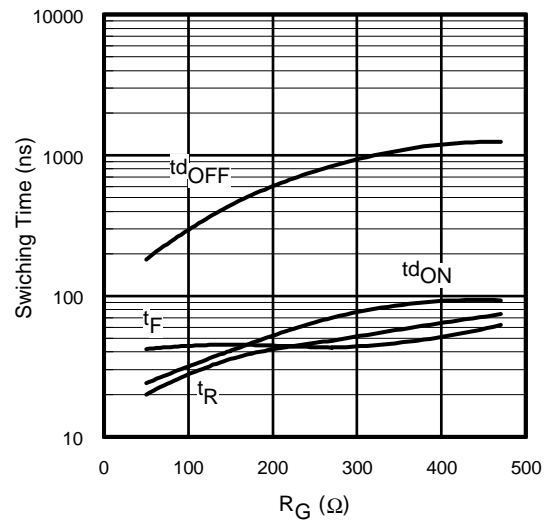

**Fig. 16** - Typ. Switching Time vs.  $R_G$   
 $T_J = 150^\circ\text{C}$ ;  $L=1.1\text{mH}$ ;  $V_{CE}= 400\text{V}$   
 $I_{CE}= 8.0\text{A}$ ;  $V_{GE}= 15\text{V}$

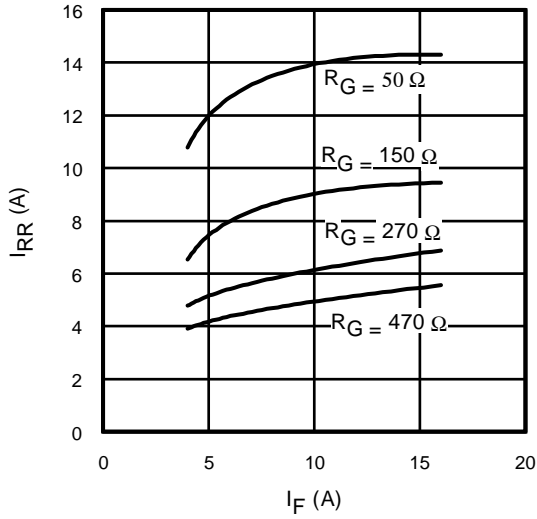

**Fig. 17** - Typical Diode  $I_{RR}$  vs.  $I_F$   
 $T_J = 150^\circ\text{C}$

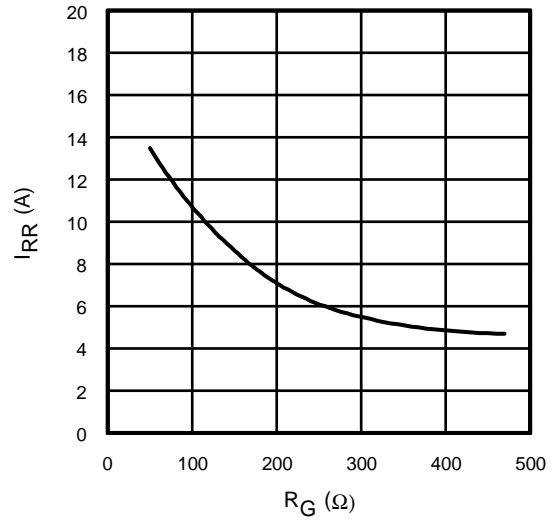

**Fig. 18** - Typical Diode  $I_{RR}$  vs.  $R_G$   
 $T_J = 150^\circ\text{C}; I_F = 8.0\text{A}$

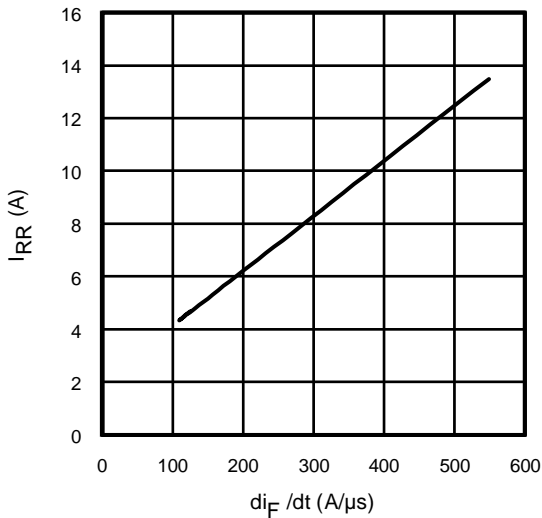

**Fig. 19**- Typical Diode  $I_{RR}$  vs.  $di_F/dt$   
 $V_{CC} = 400\text{V}; V_{GE} = 15\text{V};$   
 $I_F = 8.0\text{A}; T_J = 150^\circ\text{C}$

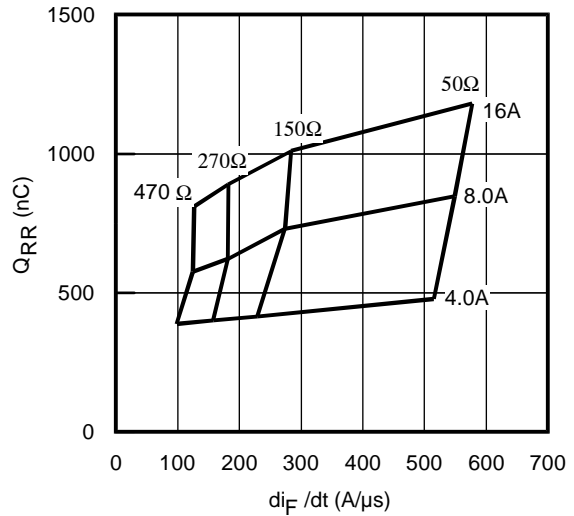

**Fig. 20** - Typical Diode  $Q_{RR}$   
 $V_{CC} = 400\text{V}; V_{GE} = 15\text{V}; T_J = 150^\circ\text{C}$

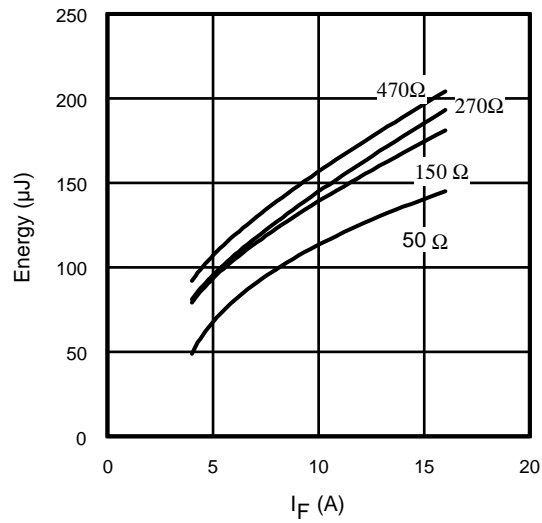

**Fig. 21** - Typical Diode  $E_{RR}$  vs.  $I_F$   
 $T_J = 150^\circ\text{C}$

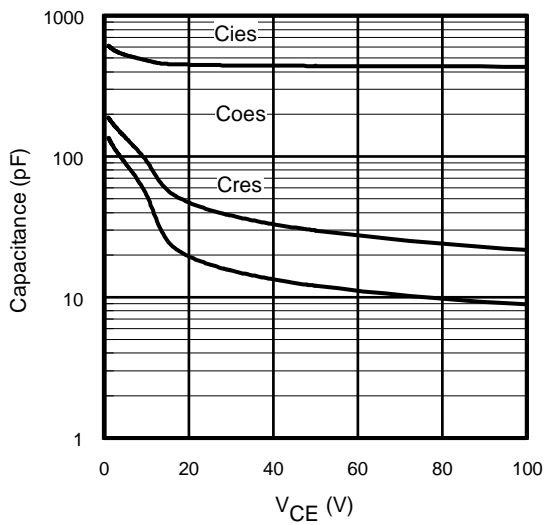

**Fig. 22**- Typ. Capacitance vs.  $V_{CE}$   
 $V_{GE} = 0\text{V}$ ;  $f = 1\text{MHz}$

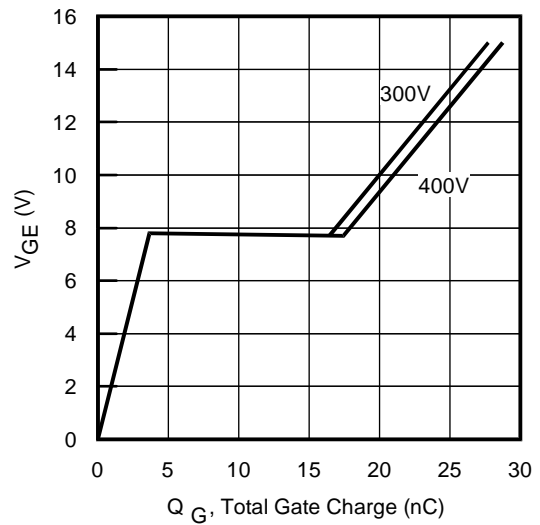

**Fig. 23** - Typical Gate Charge vs.  $V_{GE}$   
 $I_{CE} = 8.0\text{A}$ ;  $L = 600\mu\text{H}$



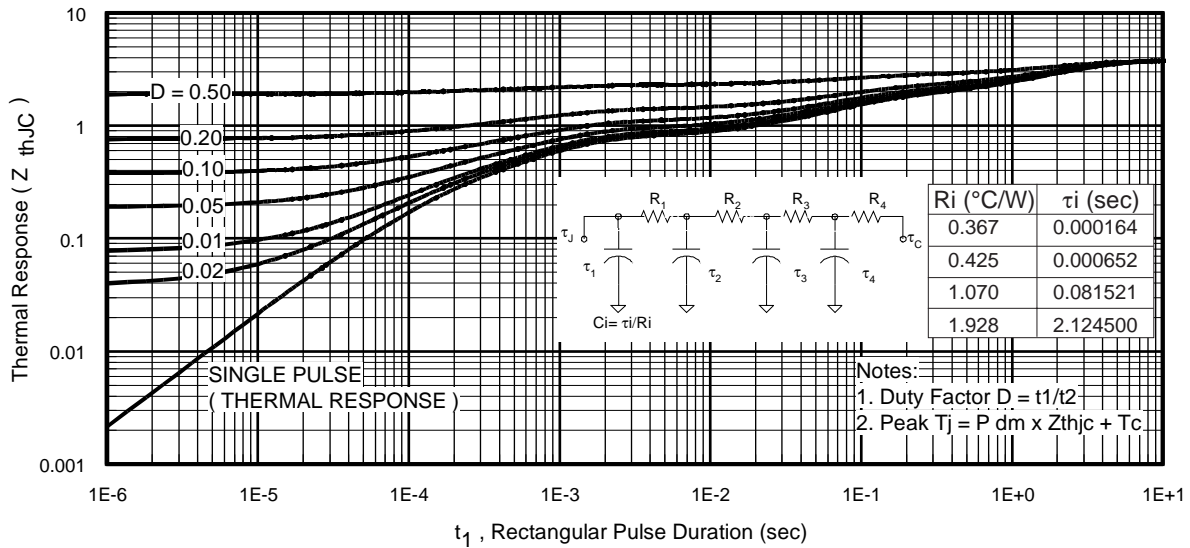

Fig 24. Maximum Transient Thermal Impedance, Junction-to-Case (IGBT)

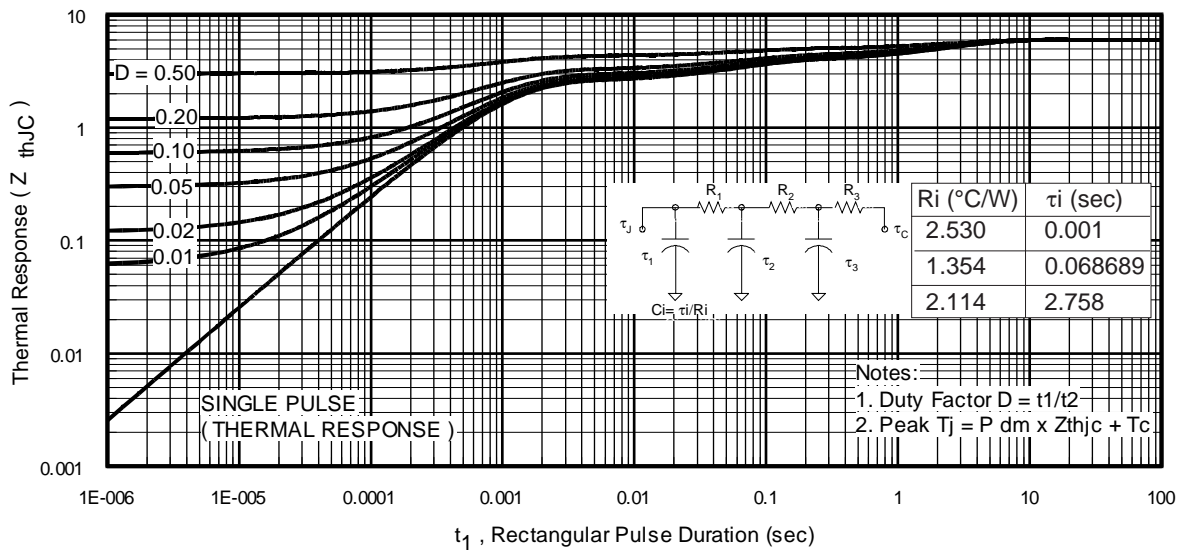
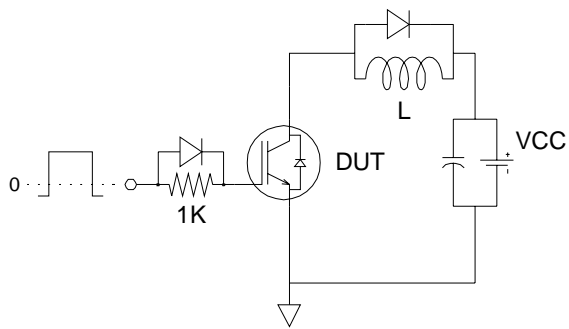
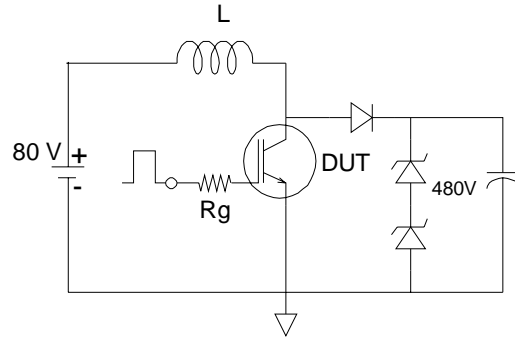

Fig 25. Maximum Transient Thermal Impedance, Junction-to-Case (DIODE)



**Fig.C.T.1** - Gate Charge Circuit (turn-off)



**Fig.C.T.2** - RBSOA Circuit

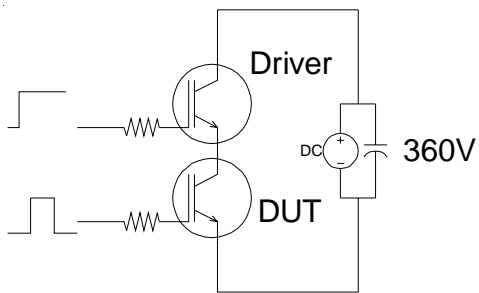

**Fig.C.T.3** - S.C.SOA Circuit

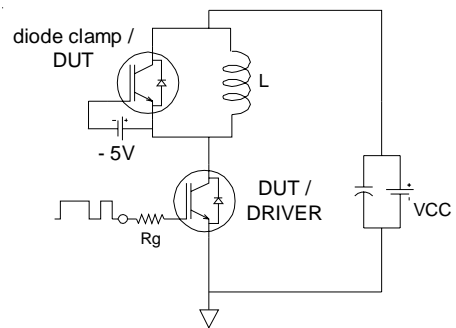

**Fig.C.T.4** - Switching Loss Circuit

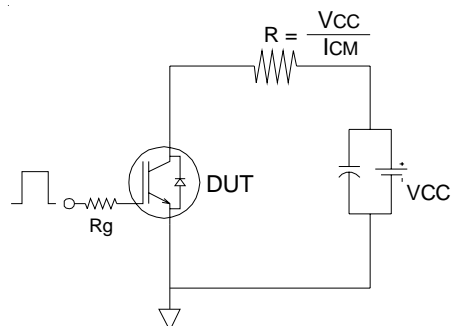

**Fig.C.T.5** - Resistive Load Circuit

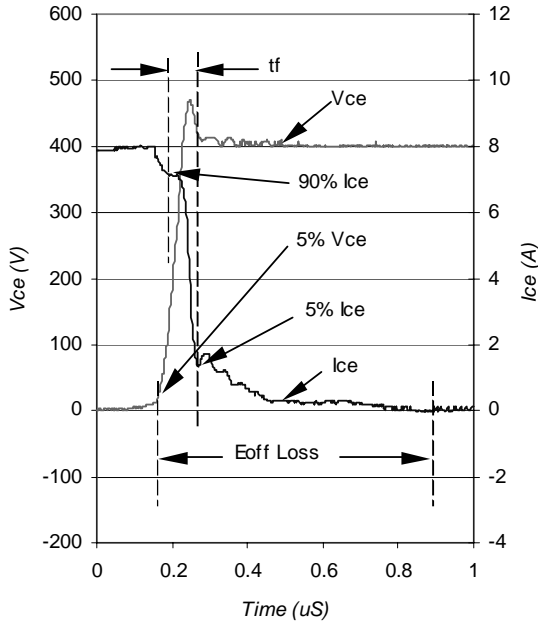

Fig. WF1- Typ. Turn-off Loss Waveform  
 @ T<sub>J</sub> = 150°C using Fig. CT.4

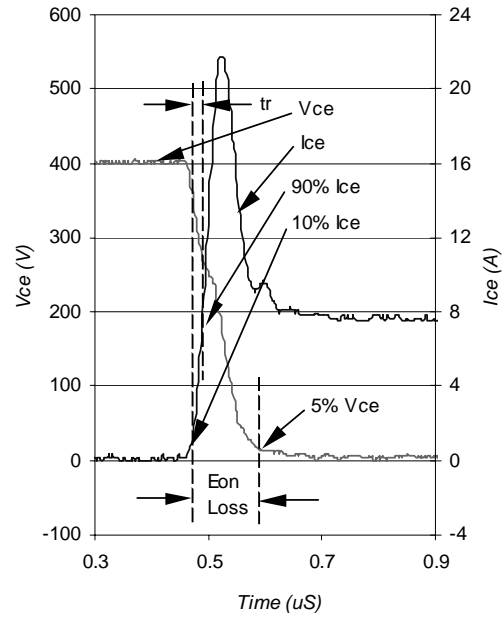

Fig. WF2- Typ. Turn-on Loss Waveform  
 @ T<sub>J</sub> = 150°C using Fig. CT.4

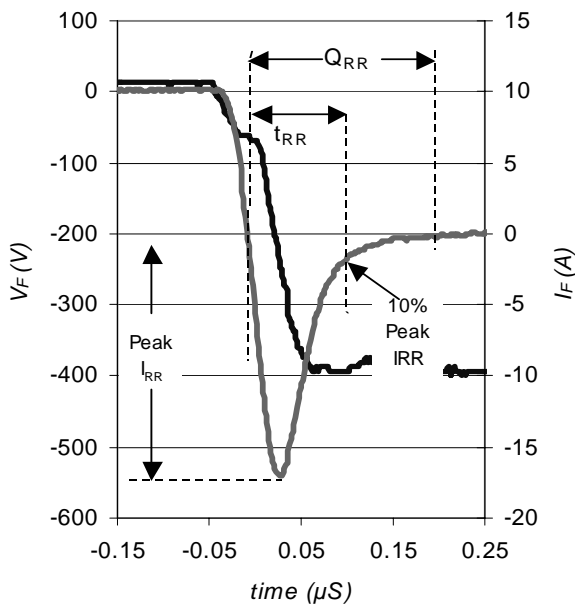

Fig. WF3- Typ. Diode Recovery Waveform  
 @ T<sub>J</sub> = 150°C using Fig. CT.4

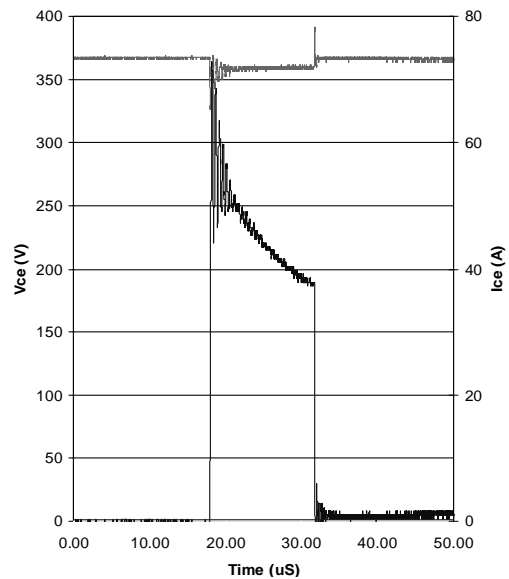
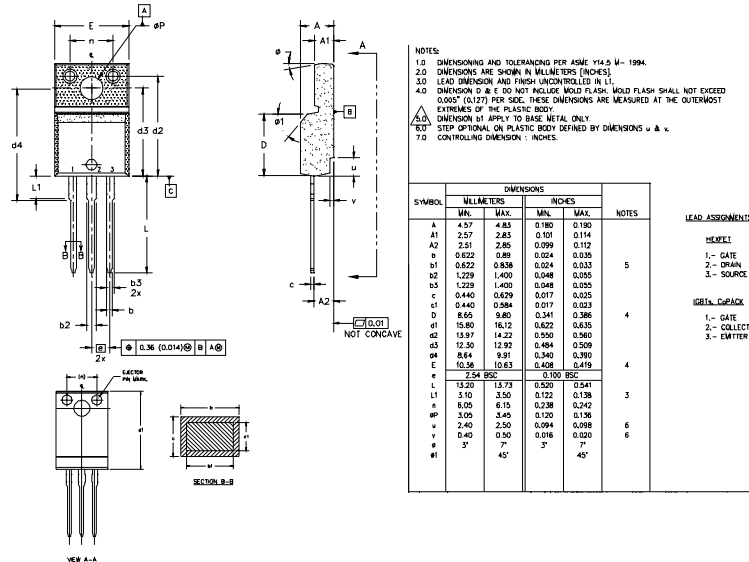

Fig. WF4- Typ. S.C Waveform  
 @ T<sub>C</sub> = 150°C using Fig. CT.3

# IRGIB7B60KD

## TO-220 Full-Pak Package Outline

Dimensions are shown in millimeters (inches)



## TO-220 Full-Pak Part Marking Information

Notes: This part marking information applies to all devices produced before 02/26/2001 and currently for parts manufactured in GB.

EXAMPLE: THIS IS AN IRFB40G WITH ASSEMBLY LOT CODE E401

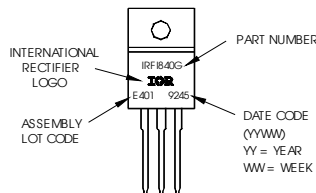

Notes: This part marking information applies to devices produced after 02/26/2001 in location other than GB.

EXAMPLE: THIS IS AN IRFB40G WITH ASSEMBLY LOT CODE 3432 ASSEMBLED ON WW 24 1999 IN THE ASSEMBLY LINE "K"

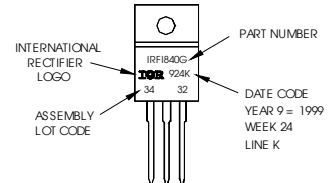

Notes:

- ①  $V_{CC} = 80\% (V_{CES})$ ,  $V_{GE} = 15V$ ,  $L = 100\mu H$ ,  $R_G = 50\Omega$ .
- ② Energy losses include "tail" and diode reverse recovery.

**TO-220AB FullPak package is not recommended for Surface Mount Application.**

Data and specifications subject to change without notice.  
This product has been designed and qualified for Industrial market.  
Qualification Standards can be found on IR's Web site.

International  
**IR** Rectifier

IR WORLD HEADQUARTERS: 233 Kansas St., El Segundo, California 90245, USA Tel: (310) 252-7105  
TAC Fax: (310) 252-7903

Visit us at [www.irf.com](http://www.irf.com) for sales contact information. 09/03

Note: For the most current drawings please refer to the IR website at:  
<http://www.irf.com/package/>