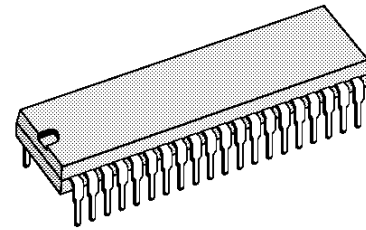


## TELETEXT DECODER WITH 8 INTEGRATED PAGES

- COMPLETE TELETEXT DECODER INCLUDING ON-CHIP 8 PAGES MEMORY, REDUCING EMC RADIATIONS
- UPWARD SOFTWARE AND HARDWARE COMPATIBLE WITH PREVIOUS SGS-THOMSON's DECODER SDA5243
- DIRECT INTERFACE TO AN EXTERNAL STATIC RAM OF 8kBYTES FOR UP TO 16 PAGES APPLICATION
- AUTOMATIC SELECTION OF UP TO SIX NATIONAL LANGUAGES
- FOUR SIMULTANEOUS PAGE REQUESTS
- DISPLAY OF THE 25TH STATUS ROW
- MICROPROCESSOR CONTROL VIA AN I<sup>2</sup>C BUS (SLAVE ADDRESS 0010001 R/W)
- DATA ACQUISITION AVAILABLE FROM LINES 2 TO 22 OR FROM A COMPLETE FIELD
- HIGH QUALITY DISPLAY USING A CHARACTER MATRIX OF 12 x 10 DOTS
- SINGLE + 5V SUPPLY VOLTAGE
- ON-CHIP MASK PROGRAMMABLE ROM CHARACTER GENERATORS
- HCMOS PROCESS

### DESCRIPTION

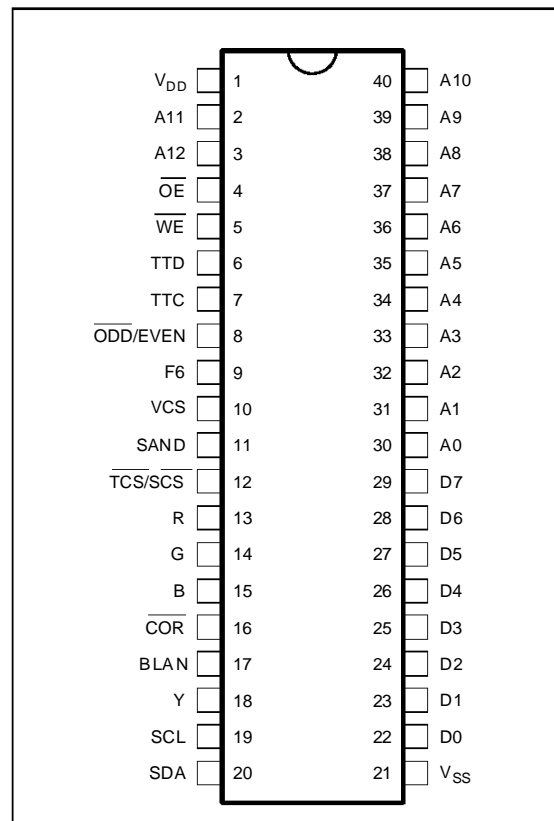
The STV5345 is a HCMOS integrated circuit which performs all the processing of logical data within a 625 lines system teletext decoder. It is designed to operate in conjunction with one-chip : the SAA5231 integrated chip which extracts Teletext information embedded in a composite video signal. Up to 8 pages of display data can be stored in internal memory. Using 8Kbytes of external memory leads to a 16 pages application. A complete system also comprises a microprocessor controlling the STV5345 via a 2-wires serial bus. An on-chip ROM memory contains the character sets. The STV5345 performs automatic selection of one of up to six natural languages. Data bytes may be decoded in either 7-Bit plus parity or in full 8-Bit formats. The chip set also supports facilities for reception and display of higher-level protocol data.



**DIP40**  
(Plastic Package)

**ORDER CODE :** STV5345      West European  
 STV5345/H      East European  
 STV5345/T      Turkish & European

### PIN CONNECTIONS



5345-01.EPS

## STV5345 - STV5345/H - STV5345/T

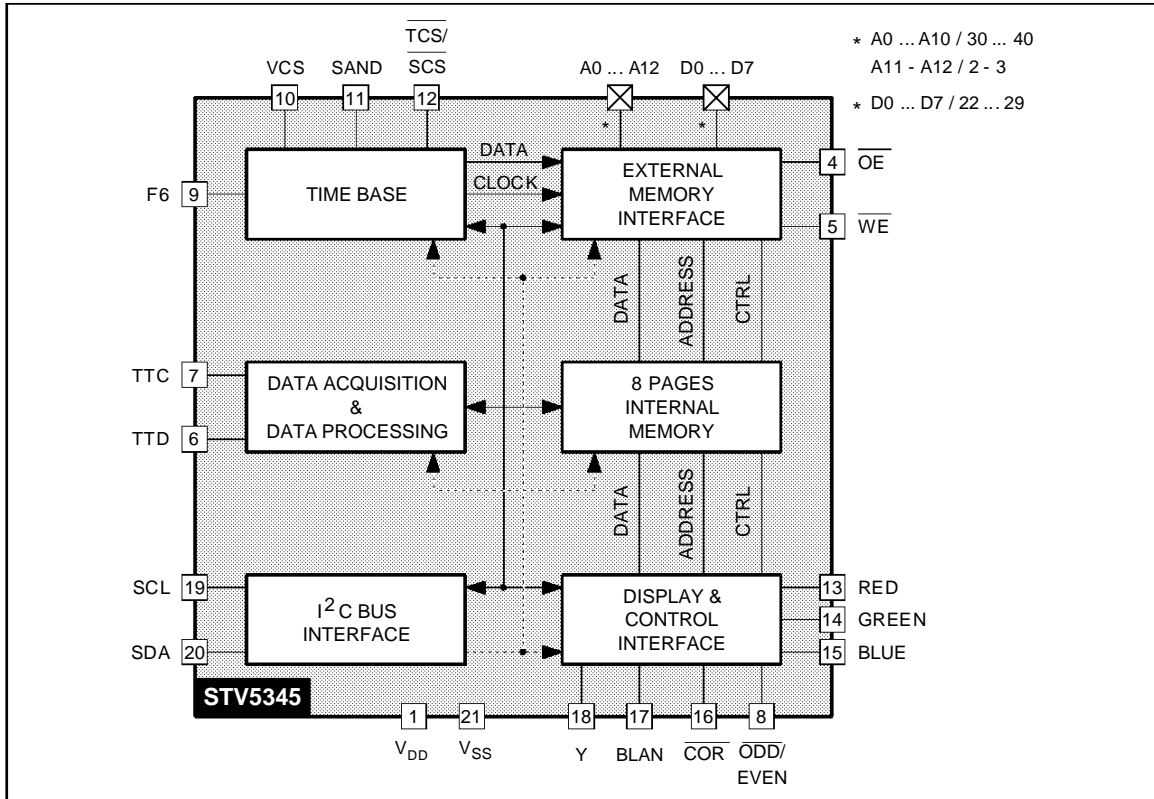
### PIN DESCRIPTION

Pin	Symbol	Function	Description
1	V <sub>DD</sub>	+5V	Positive supply voltage
2,3,40 *	A11, A12, A10	Chapter address	Address selection outputs for 1 of 8 external static RAM chapters each of 1 kBytes.
4 *	$\overline{\text{OE}}$	Output enable	Active-low external static RAM output enable control signal.
5 *	$\overline{\text{WE}}$	Write enable	Active-low external static RAM write enable control signal. It supports write-cycles interleaved with read-cycles.
6	TTD	Teletext data input	An A.C. coupled teletext data input supplied by the SAA5231 chip is latched to V <sub>SS</sub> between 4 and 8 $\mu$ s after each TV line.
7	TTC	Teletext clock input	A 6.9375MHz clock signal, supplied by the SAA5231 chip, is internally A.C. coupled, clamped and buffered.
8	$\overline{\text{ODD/EVEN}}$	Interlaced mode state output	High for even numbered and low for odd-numbered frames. The value is valid 2 $\mu$ s before the end of lines 311 and 624.
9	F6	Character display clock signal	The 6MHz clock signal, supplied by the SAA5231 chip is internally A.C. coupled, clamped and buffered.
10	VCS	Video composite synchronization input signal	Active high VCS input.
11	SAND	Sandcastle	Three level output pulse to the SAA5231 device. Phase lock, blanking signal, and color burst components are contained in this signal.
12	$\overline{\text{TCS/SCS}}$	Input / output composite synchronization signal	Scan composite input signal (SCS) for the display synchronization or Text composite sync. (TCS) output signal to the SAA5231. Both signals are active low.
13,14,15	R G B	Red, green, blue	Character and background colors active-high open-drain outputs.
16	$\overline{\text{COR}}$	Contrast reduction	Open-drain active-low output supporting optimal display of characters in "mixed mode" operation.
17	BLAN	Blanking signal output	Open-drain active high output for TV-image blanking in normal and mixed-mode operation.
18	Y	Foreground output	Open-drain active-high output with foreground information. Can be used for printer command.
19	SCL	Serial clock	Microprocessor clock input via serial bus.
20	SDA	Serial data input / output	Open-drain microprocessor serial data input/output via serial bus.
21	V <sub>SS</sub>	0 Volt	Ground.
22-29 *	D0-D7	Parallel data input / output	Eight tri-state input/output for data read/write from/to an external static RAM.
30-39 *	A0-A9	Address signals	Ten addresses output pins for accessing to individual Bytes of a 1 kByte chapter stored in an external Static RAM.

\* Pins only activated when 8KBytes of external memory are addressed, otherwise pins  $\overline{\text{OE}}$  and  $\overline{\text{WE}}$  remain high, and others remain low.

5345-01.TBL

**BLOCK DIAGRAM**



**ABSOLUTE MAXIMUM RATINGS**

Symbol	Parameter	Value	Unit
V <sub>DD</sub>	Power Supply Range	-0.3, +6.0	V

INPUT VOLTAGE RANGE :

V <sub>I</sub>	VCS, SDA, SCL, D0-D7	-0.3, V <sub>DD</sub> + 0.5	V
V <sub>I</sub>	TTD, F6, TCS/SCS, TTC	-0.3, +10	V

OUTPUT VOLTAGE RANGE :

V <sub>O</sub>	SAND, A0-A12, OE, WE, D0-D7, SDA, ODD/EVEN, R, G, B	-0.3, V <sub>DD</sub>	V
V <sub>O</sub>	BLAN, COR, Y, TCS/SCS	-0.3, V <sub>DD</sub>	V
T <sub>stg</sub>	Storage Temperature Range	-20, +125	°C
T <sub>A</sub>	Operating Ambient Temperature Range	-20, +70	°C

**ELECTRICAL CHARACTERISTICS**

V<sub>DD</sub> = 5V, V<sub>SS</sub> = 0V, T<sub>A</sub> = - 20 to + 70°C

Symbol	Parameter	Min	Typ	Max	Unit
V <sub>DD</sub>	Supply Voltage (Pin 1)	4.5	5	5.5	V
I <sub>DD</sub>	Supply Current (operating mode)		15	40	mA

## STV5345 - STV5345/H - STV5345/T

### ELECTRICAL CHARACTERISTICS (continued)

$V_{DD} = 5V$ ,  $V_{SS} = 0V$ ,  $T_A = -20$  to  $+70^{\circ}C$

Symbol	Parameter	Min	Typ	Max	Unit
<b>INPUTS</b>					
TTD (Pin 6)					
$C_{EXT}$	Ext. Coupling Capacitor			50	nF
$V_{I(p-p)}$	Input Voltage p-p	2		7	V
$t_r, t_f$	Input Rise / Fall Times	10		80	ns
$t_{DS}$	Input Set-up Time	40			ns
$t_{DH}$	Input Hold Time	40			ns
$I_{I(L)}$	Input Leakage Current ( $V_I = 0$ to $V_{DD}$ )	-10		+10	$\mu A$
$C_I$	Input capacitance			7	pF
TTC, F6 (Pins 7,9)					
$V_I$	DC Input Voltage	-0.3		+10	V
$V_{I(p-p)}$	AC Input Voltage F6 AC Input Voltage TTC	1 1.5		7 7	V V
$\pm V_P$	Input Peak Rel. 50 % Duty	0.2		3.5	V
$f_{TTC}$	TTC Clock Frequency		6.9375		MHz
$f_{F6}$	F6 Clock Frequency		6		MHz
$t_r, t_f$	Clock Rise / Fall Times	10		80	ns
$I_{I(L)}$	Input Leakage Current ( $V_I = 0$ to 10V)	-10		+10	$\mu A$
$C_I$	Input Capacitance			10	pF
VCS (Pin 10)					
$V_{IL}$	Low Level Input Voltage	0		0.8	V
$V_{IH}$	High Level Input Voltage	2		$V_{DD}$	V
$t_r, t_f$	Input Rise / Fall Times			500	ns
$I_{I(L)}$	Input Leakage Current ( $V_I = 0$ to $V_{DD}$ )	-10		+10	$\mu A$
$C_I$	Input Capacitance			7	pF
SCL (Pin 19)					
$V_{IL}$	Low Level Input Voltage	0		1.5	V
$V_{IH}$	High Level Input Voltage	3		$V_{DD}$	V
$f_{SCL}$	SCL Clock Frequency			100	kHz
$t_r, t_f$	Input Rise / Fall Times			2	$\mu s$
$I_{I(L)}$	Input Leakage Current ( $V_I = 0$ to $V_{DD}$ )	-10		+10	$\mu A$
$C_I$	Input Capacitance			7	pF
<b>INPUT/OUTPUTS</b>					
$\overline{TCS}$ (output), $SCS$ (input) (Pin12)					
$V_{IL}$	Low Level Input Voltage	0		1.5	V
$V_{IH}$	High Level Input Voltage	3		8	V
$t_r, t_f$	Input Rise / Fall Times			500	ns
$I_{I(L)}$	Input Leakage Current ( $V_I = 0$ to $V_{DD}$ and output in high impedance state)	-10		+10	$\mu A$
$C_I$	Input Capacitance			7	pF
$V_{OL}$	Low Level Output Voltage ( $I_{OL} = 0.4mA$ )	0		0.4	V
$V_{OH}$	High Level Output Voltage ( $-I_{OH} = 0.2mA$ )	2.4		$V_{DD}$	V
$t_r, t_f$	Output Rise / Fall Times between 0.6V and 2.2V			100	ns
$C_L$	Load Capacitance			50	pF

5345-04.TBL

**ELECTRICAL CHARACTERISTICS** (continued) $V_{DD} = 5V$ ,  $V_{SS} = 0V$ ,  $T_A = -20$  to  $+70^{\circ}C$ 

Symbol	Parameter	Min	Typ	Max	Unit
--------	-----------	-----	-----	-----	------

## INPUT/OUTPUTS (continued)

SDA (Pin 20)					
$V_{IL}$	Low Level Input Voltage	0		1.5	V
$V_{IH}$	High Level Input Voltage	3		$V_{DD}$	V
$t_r, t_f$	Input Rise / Fall Times			2	$\mu s$
$I_{I(L)}$	Input Leakage Current ( $V_I = 0$ to $V_{DD}$ and output in high impedance state)	-10		+10	$\mu A$
$C_I$	Input Capacitance			7	pF
$V_{OL}$	Low Level Output Voltage ( $I_{OL} = 3mA$ )	0		0.5	V
$t_f$	Output Fall Time between 3.0V and 1.0V			200	ns
$C_L$	Load Capacitance			400	pF
D0-D7 (Pins 22-29)					
$V_{IL}$	Low Level Input Voltage	0		0.8	V
$V_{IH}$	High Level Input Voltage	2		$V_{DD}$	V
$I_{I(L)}$	Input Leakage Current ( $V_I = 0$ to $V_{DD}$ and output in high impedance state)	-10		+10	$\mu A$
$C_I$	Input Capacitance			7	pF
$V_{OL}$	Low Level Output Voltage ( $I_{OL} = 1.6mA$ )	0		0.4	V
$V_{OH}$	High Level Output Voltage ( $-I_{OH} = 0.2mA$ )	2.4		$V_{DD}$	V
$t_r, t_f$	Output Rise / Fall Times between 0.6V and 2.2V			50	ns
$C_L$	Load Capacitance			120	pF

## OUTPUTS

A0-A12, $\overline{OE}$ , $\overline{WE}$ (Pins 30-40,2,3,4,5,)					
$V_{OL}$	Low Level Output Voltage ( $I_{OL} = 1.6mA$ )	0		0.4	V
$V_{OH}$	High Level Output Voltage ( $-I_{OH} = 0.2mA$ )	2.4		$V_{DD}$	V
$t_r, t_f$	Output Rise / Fall Times between 0.6V and 2.2V			50	ns
$C_L$	Load Capacitance			120	pF
$\overline{ODD/EVEN}$ (Pin 8)					
$V_{OL}$	Low Level Output Voltage ( $I_{OL} = 0.4mA$ )	0		0.4	V
$V_{OH}$	High Level Output Voltage ( $-I_{OH} = 0.2mA$ )	2.4		$V_{DD}$	V
$t_r, t_f$	Output Rise / Fall Times between 0.6V and 2.2V			100	ns
$C_L$	Load Capacitance			50	pF
SAND (Pin 11)					
$V_{OL}$	Low Level Output Voltage ( $I_{OL} = 0.2mA$ )	0	-	0.25	V
$V_{OI}$	Middle Level Output Voltage ( $I_{OL} = \pm 10 \mu A$ )	1.1	-	2.9	V
$V_{OH}$	High Level Output Voltage ( $-I_{OH} = 0$ to $10 \mu A$ )	4		$V_{DD}$	V
$t_{r1}$	Output Rise Time : ● $V_{OL}$ to $V_{OI}$ from 0.4 to 1.1V ● $V_{OI}$ to $V_{OH}$ from 2.9 to 4.0V	-	-	400	ns
$t_{r2}$		-	-	200	
$t_f$	Output Fall Time $V_{OH}$ to $V_{OI}$ from 4.0 to 0.4V	-	-	50	ns
$C_L$	Load Capacitance	-	-	30	pF

5345-08.TBL

## STV5345 - STV5345/H - STV5345/T

### ELECTRICAL CHARACTERISTICS (continued)

$V_{DD} = 5V$ ,  $V_{SS} = 0V$ ,  $T_A = -20$  to  $+70^{\circ}C$

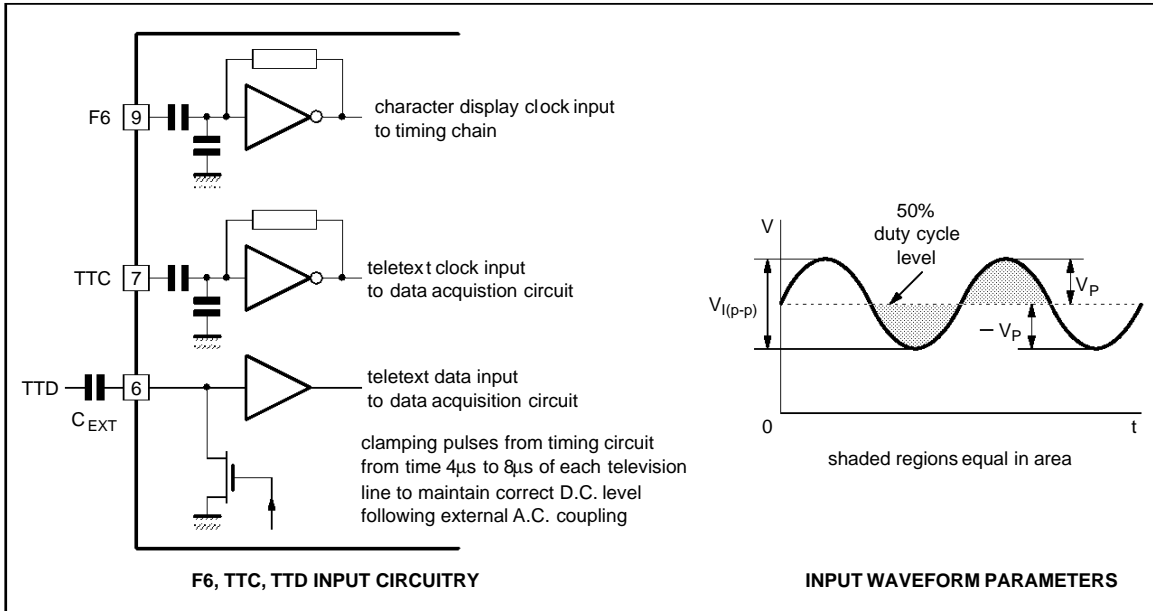
Symbol	Parameter	Min	Typ	Max	Unit
OUTPUTS (continued)					
R, G, B, $\overline{COR}$ , BLAN, Y (Pins 13-18)					
$V_{OL}$	Low Level Output Voltage : ● $I_{OL} = 2mA$ ● $I_{OL} = 5mA$	0 0	- -	0.4 1	V
$V_{PU}$	Pull-up Voltage (with $R = 1k\Omega$ to $V_{DD}$ )	-	-	$V_{DD}$	V
$t_f$	Output Fall Time from 4.5 to 1.5V (with $R = 1k\Omega$ to $V_{DD}$ )	-	-	20	ns
$t_{SK}$	Skew Delay on Falling Edges (at 3V with $R = 1k\Omega$ connected to $V_{DD}$ )	-	-	20	ns
$C_L$	Load Capacitance	-	-	25	pF
$I_{LO}$	Output Leakage Current ( $V_{PU} = 0$ to $V_{DD}$ output off)	-	-	20	$\mu A$

### TIMING

SERIAL BUS (referred to $V_{IH} = 3V$ , $V_{IL} = 1.5V$ ) (see Fig. 6)					
$t_{LOW}$	Low Period Clock	4	-	-	$\mu s$
$t_{HIGH}$	High Period Clock	4	-	-	$\mu s$
$t_{SU, DAT}$	Data Set-up Time	250	-	-	ns
$t_{HD, DAT}$	Data Hold Time	170	-	-	ns
$t_{SU, STO}$	Stop Set-up Time from Clock High	4	-	-	$\mu s$
$t_{BUF}$	Start Set-up Time Following a Stop	4	-	-	$\mu s$
$t_{HD, STA}$	Start Hold Time	4	-	-	$\mu s$
$t_{SU, STA}$	Start Set-up Time Following Clock Low to High Transition	4	-	-	$\mu s$
MEMORY INTERFACE referred to $V_{IL} = 1.5V$ (see Fig. 7)					
$t_{CY}$	Cycle Time	-	500	-	ns
$t_{OE}$	Address Change to $\overline{OE}$ Low	60	-	-	ns
$t_{ADDR}$	Address Active Time	450	500	-	ns
$t_{OEW}$	$\overline{OE}$ Pulse Duration	320	-	-	ns
$t_{ACC}$	Access Time from $\overline{OE}$ to Data Valid	-	-	200	ns
$t_{DH}$	Data Hold Time from $\overline{OE}$ High or Address Change	0	-	-	ns
$t_{WE}$	Address Change to $\overline{WE}$ Low	40	-	-	ns
$t_{WEW}$	$\overline{WE}$ Pulse Duration	200	-	-	ns
$t_{DS}$	Data Set-up Time to $\overline{WE}$ High	100	-	-	ns
$t_{DHWE}$	Data Hold Time from $\overline{WE}$ High	20	-	-	ns
$t_{WR}$	Write Recovery Time	25	-	-	ns

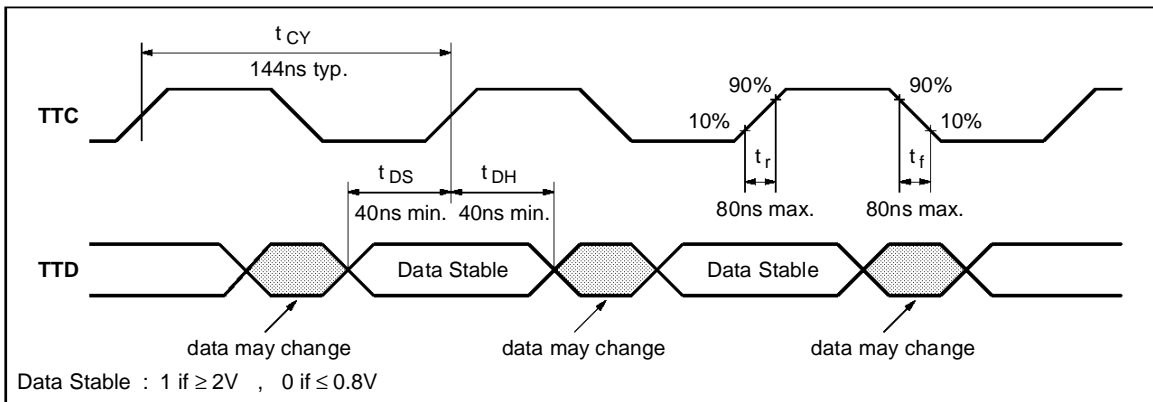
5345-06.TBL

Figure 1 : F6, TTC, TTD Input Internal Connections



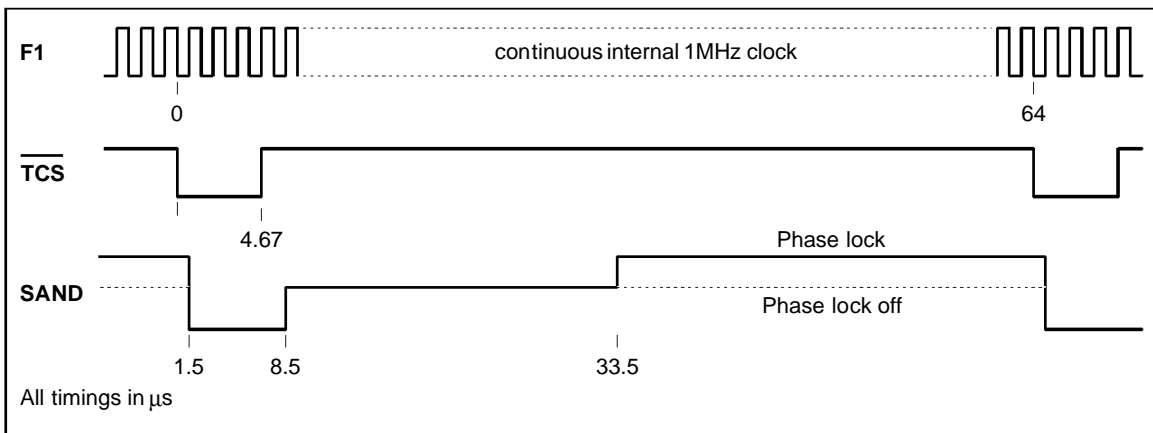
5345-03.EPS

Figure 2 : Teletext Data Input Timing



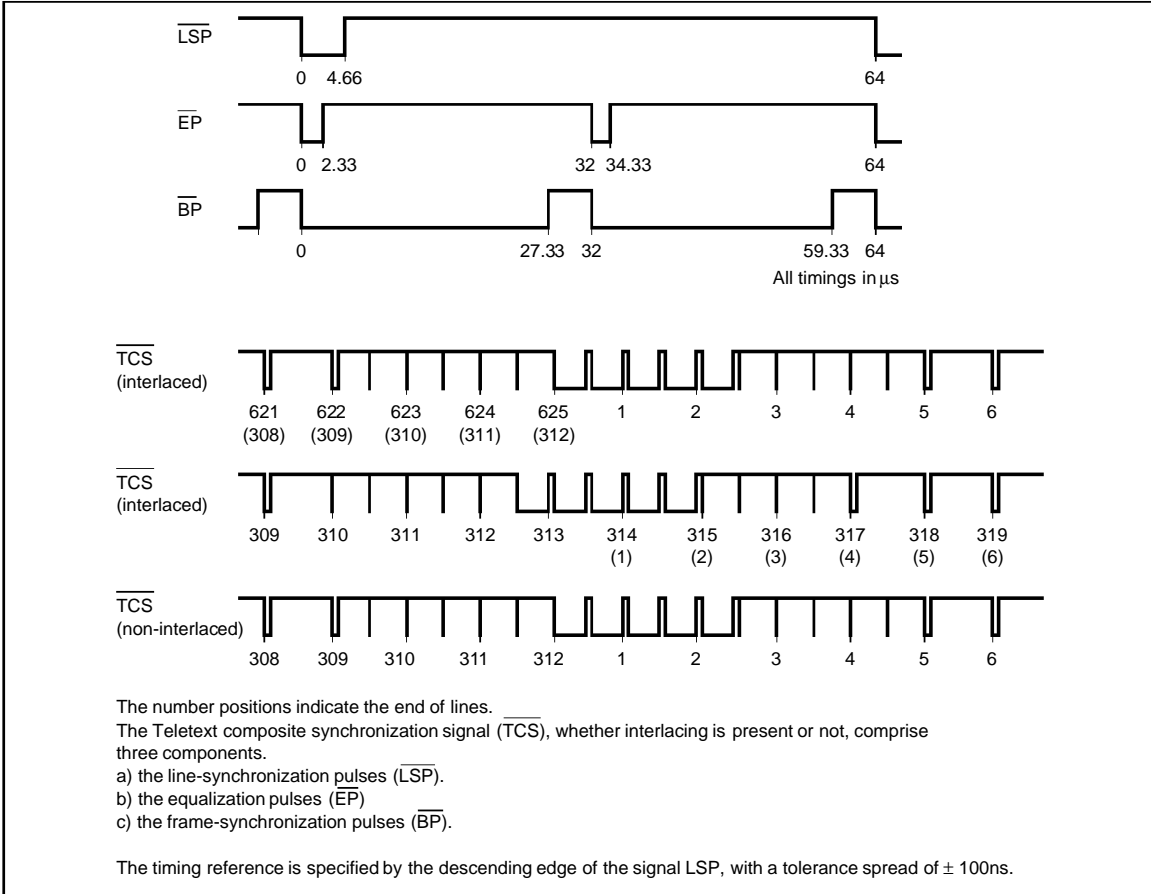
5345-04.EPS

Figure 3 : Synchronization Timing



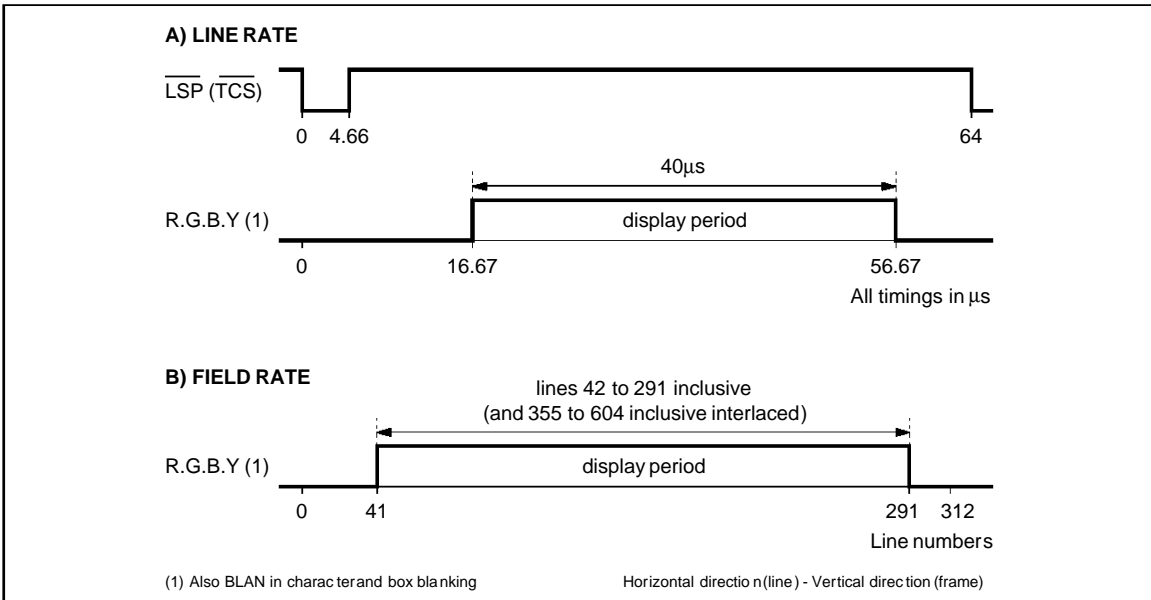
5345-05.EPS

Figure 4 : Composite Sync. Waveforms



5345-08.EPS

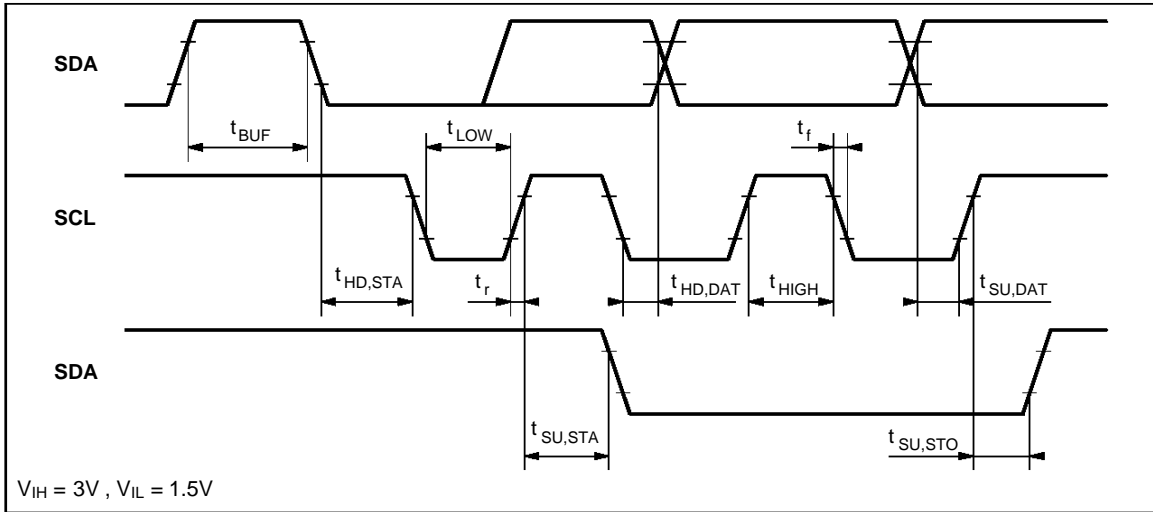
Figure 5 : Display Output Timing



5345-07.EPS

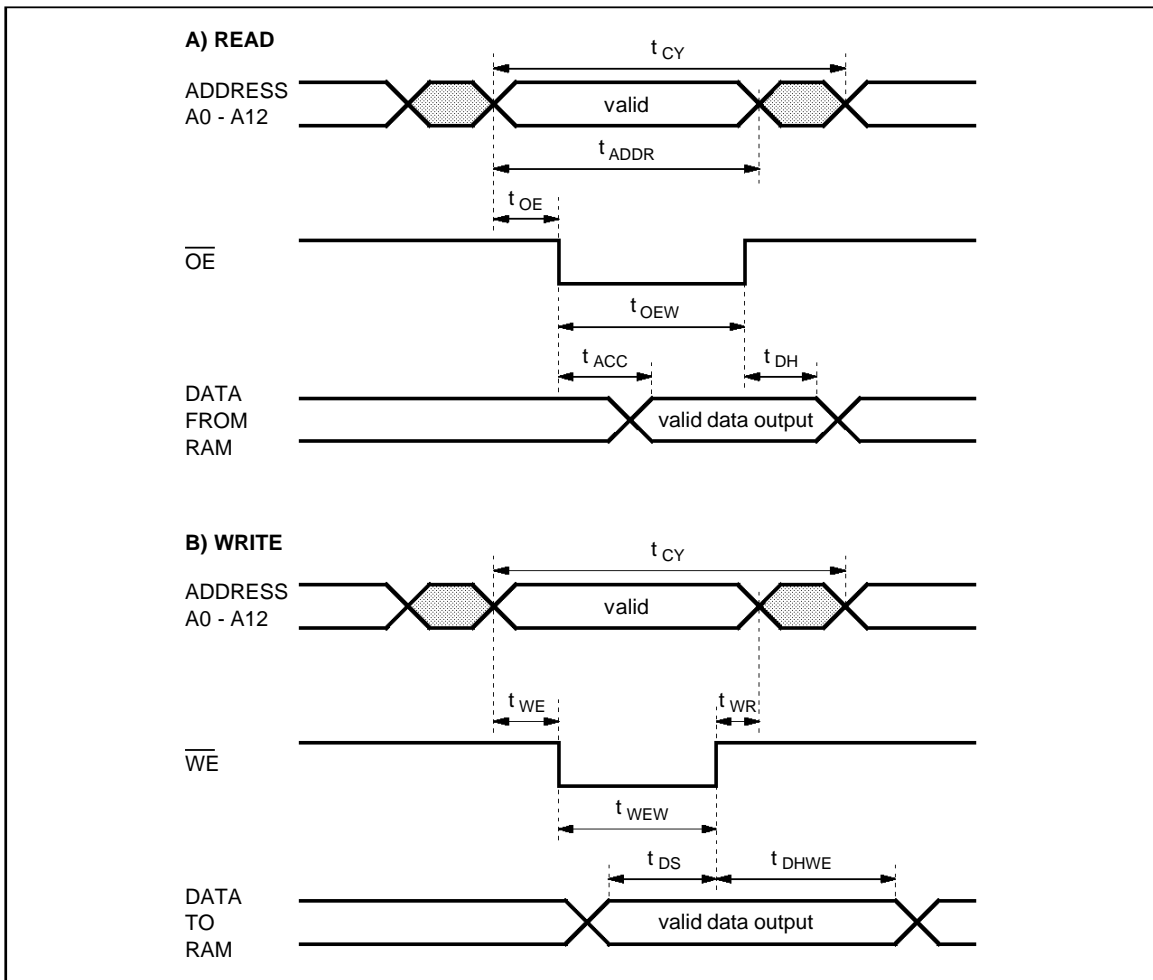


Figure 6 : Serial Bus Timing



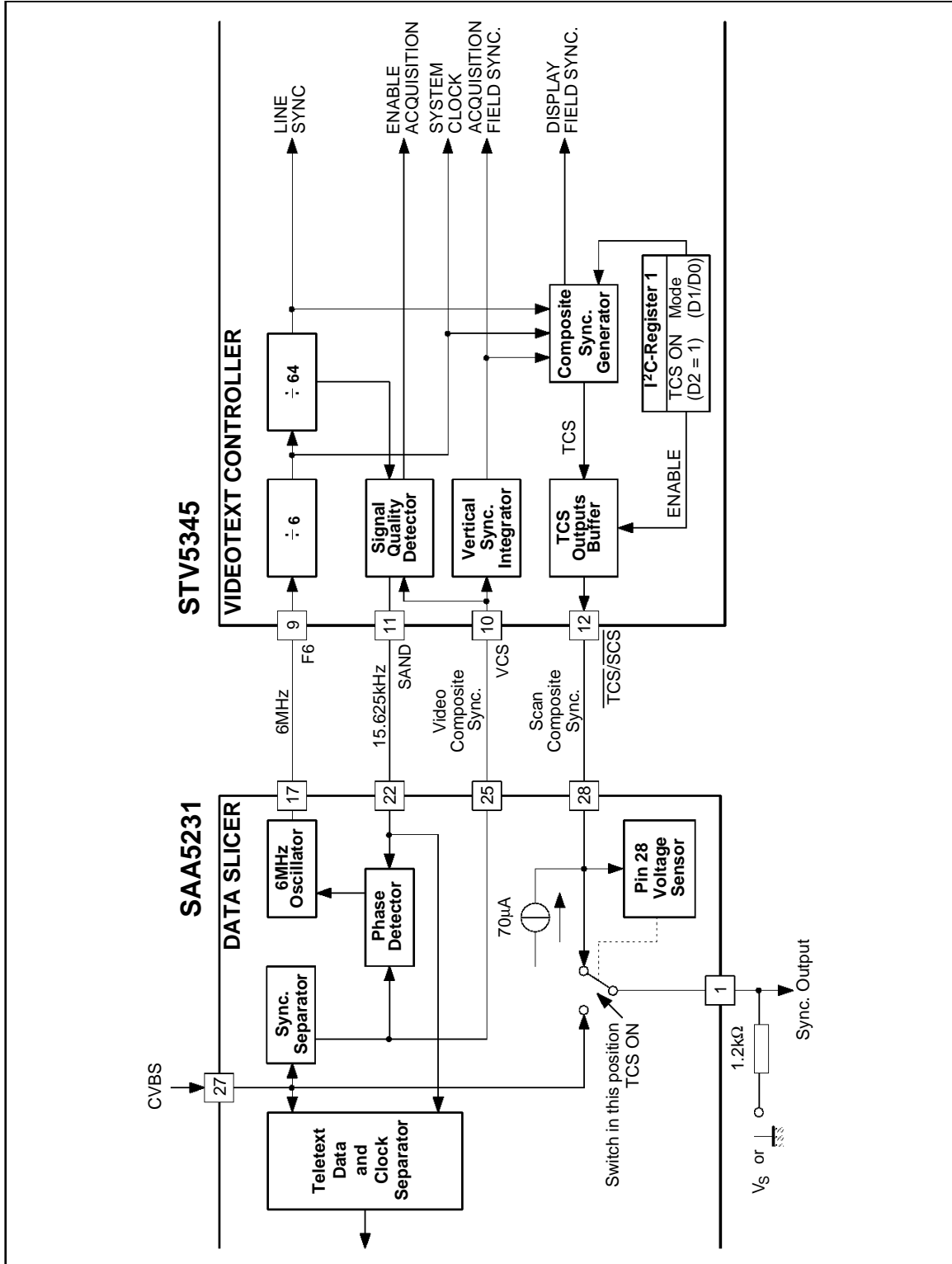
5345-08.EPS

Figure 7 : Memory Interface Timing



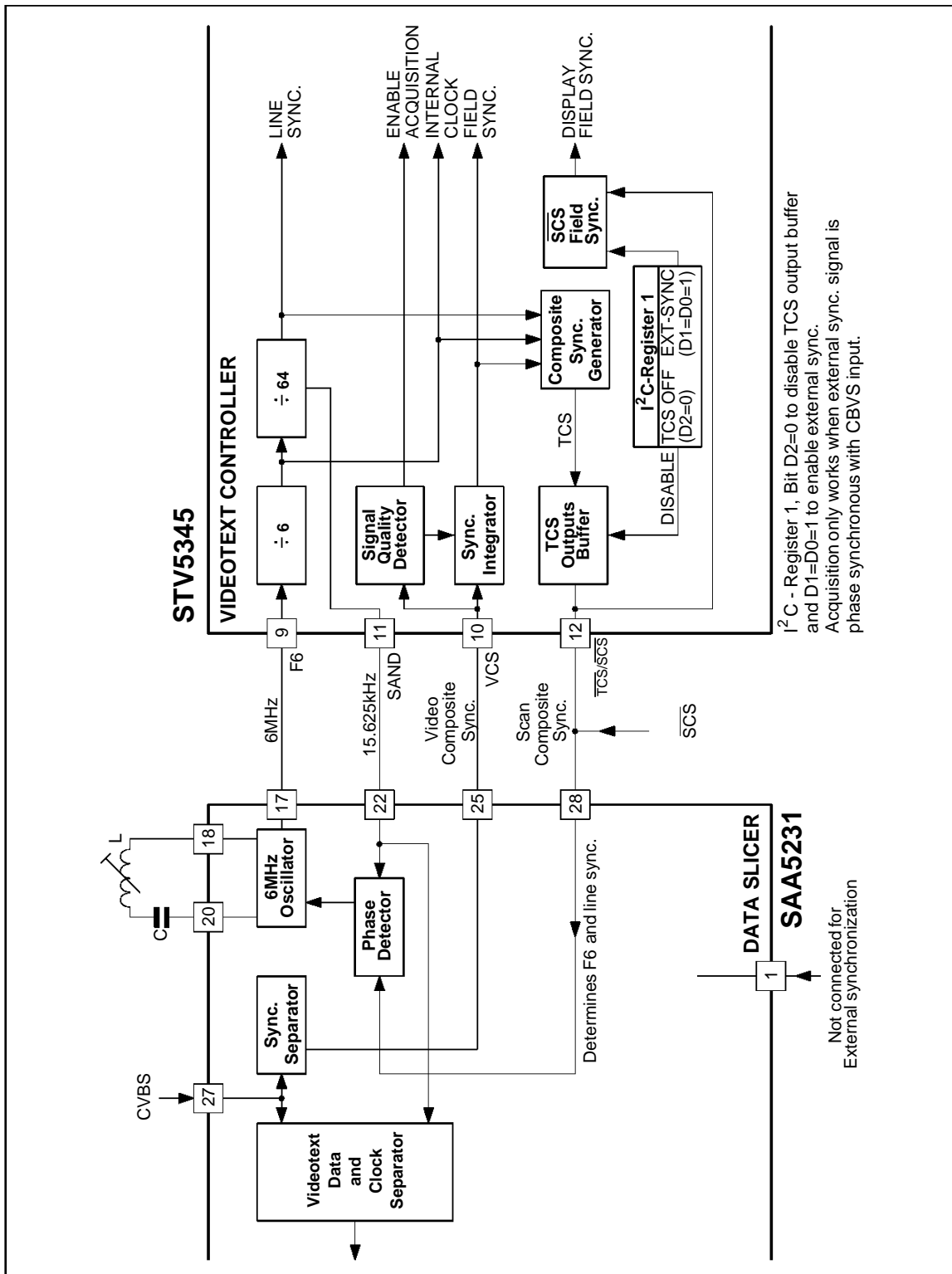
5345-08.EPS

Figure 8 : Master Synchronization Mode



5345-10.EPS

Figure 9 : Slave Synchronization Mode



5345-11.EPS



**APPLICATION NOTES**

**ORGANIZATION OF A PAGE-MEMORY**

The organization of a page-memory is shown in Figure 10.

The STV5345 chip provides a display format of 25 rows of 40 characters per row.

The organization is as follows :

Row zero contains the page header.

The first seven characters (0 - 6) are used for messages regarding the operational status.

The eighth character is an alphanumeric control character either "white" or "green" defining the "search" status of the page. When it is "white" the operational state is normal and the header appears

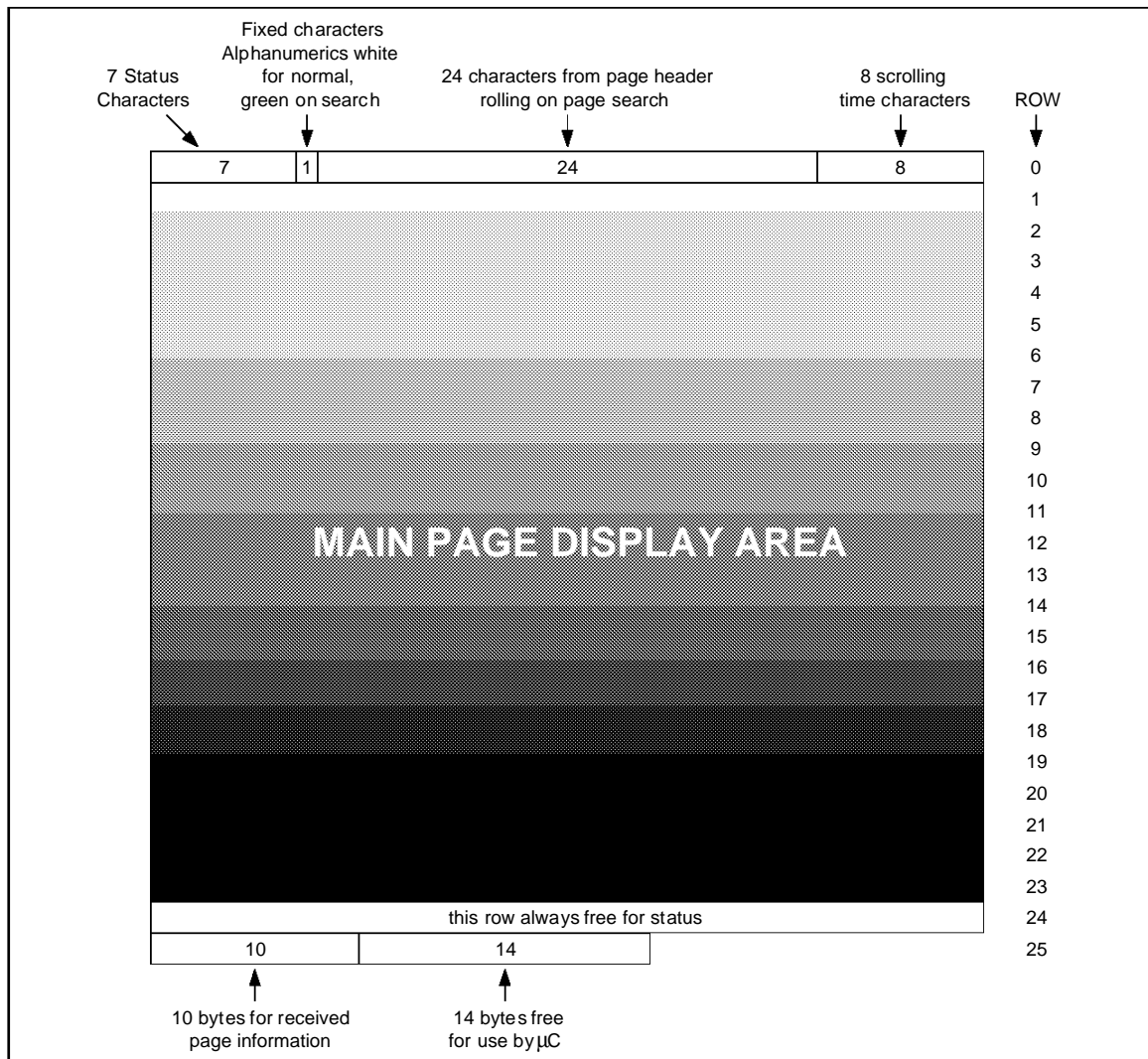
white ; when it is "green" the operational state corresponds to "search mode" and the header appears green. The following twenty-four characters give the header of the requested page when the system is in search mode. The last eight characters display the time of day.

Row number twenty-four is used by the microprocessor for the display of information.

Row twenty-five comprises ten bytes of control data concerning the received page (see Table 1) and fourteen free bytes which can be used by the microprocessor.

**PAGE MEMORY ORGANISATION**

**Figure 10**



5345-13.EPS

GHOST ROW STORAGE ORGANIZATION

Row Address of Stored Data	Designation Code	Row (Packet) Number	Function
0	0 0 0 0	X / 26	Enhanced display facilities
1	0 0 0 1		
2	0 0 1 0		
3	0 0 1 1		
4	0 1 0 0		
5	0 1 0 1		
6	0 1 1 0		
7	0 1 1 1		
8	1 0 0 0		
9	1 0 0 1		
10	1 0 1 0		
11	1 0 1 1		
12	1 1 0 0		
13	1 1 0 1		
14	1 1 1 0		
15	0 0 1 0	X / 28	Page related character set
16	0 0 0 0	X / 27	Linked pages
17	0 0 0 1		
18	0 0 1 0		
19	0 0 1 1		
20		X / 24	Page extension
21		X / 25	Page extension
22	0 0 0 0	X / 28	Magazine related character set
23	X X X X	8 / 30	Broadcasting service data packet
24		Not used	
25		Not used	

Page related data stored in chapter corresponding to level 1 data,  
i.e. For 0 goes in 4  
" 1 " " 5  
" 2 " " 6  
" 3 " " 7

Stored in chapter 4 only

5345-07.TBL

Table 1 : Row 25 received page control data format

D0	PU0	PT0	MU0	MT0	HU0	HT0	C7	C11	MAG0	0
D1	PU1	PT1	MU1	MT1	HU1	HT1	C8	C12	MAG1	0
D2	PU2	PT2	MU2	MT2	HU2	C5	C9	C13	MAG2	0
D3	PU3	PT3	MU3	C4	HU3	C6	C10	C14	0	0
D4	HAM	HAM	HAM	HAM	HAM	HAM	HAM	HAM	FOUND	0
D5	0	0	0	0	0	0	0	0	0	PBLF
D6	0	0	0	0	0	0	0	0	0	0
D7	0	0	0	0	0	0	0	0	0	0
COLUMN	0	1	2	3	4	5	6	7	8	9

Page number : - MAG = magazine, PU = page units, PT = page tens.  
Page sub-code : - MU = minutes units, MT = minutes tens, HU = hours units, HT = hours tens.  
PBLF = page being looked for, FOUND = low for page found, HAM = hamming error in byte, C4-14 = control bits.

5345-08.TBL

REGISTER MAP (see Table 2)

Registers R0 to R10 and R12 are write only whilst R11A is a read/write and R11B is a read only register respect to the microprocessor.

The automatic succession on a byte basis is indicated by the arrows in Table 2.

In the normal operating mode TA, TB and TC should be set to logic level 0.

After power-up the contents of the registers are as

follows : all bits in registers R0 to R12 are cleared to zero with the exception of bits D0 and D1 in registers R5 and R6 which are set to logical one.

After power-up all the memory bytes are preset to hexadecimal value 20 H (space) with the exception of the byte corresponding to row 0 of column 7 of chapter 0 which is set to the value corresponding to "alpha white" hexadecimal value 07 H.

Table 2 : Register specification

D7	D6	D5	D4	D3	D2	D1	D0	
*	*	*	*	*	EVEN OFF	TC	SEL11B	R0 Mode 0
TA	7 + P/ 8 BIT	ACQ. ON/OFF	GHOST ROW ENABLE	DEW/ FULL FIELD	TCS ON	T1	T0	R1 Mode 1
BLOCK SELECT A3	BANK SELECT A2	ACQ. CCT A1	ACQ. CCT A0	TB	START COLUMN SC2	START COLUMN SC1	START COLUMN SC0	R2 Page request address
*	*	*	PRD4	PRD3	PRD2	PRD1	PRD0	R3 Page request data
*	*	*	*	A3	A2	A1	A0	R4 Display chapter
BKGND OUT	BKGND IN	COR OUT	COR IN	TEXT OUT	TEXT IN	PON OUT	PON IN	R5 Display control (normal)
BKGND OUT	BKGND IN	COR OUT	COR IN	TEXT OUT	TEXT IN	PON OUT	PON IN	R6 Display control (newsflash / subtitle)
STATUS ROW BTM/TOP	CURSOR ON	CONCEAL/ REVEAL	TOP/ BOTTOM	SINGLE/ DOUBLE HEIGHT	BOX ON 24	BOX ON 1-23	BOX ON 0	R7 Display mode
*	*	*	A3	CLEAR MEM.	A2	A1	A0	R8 Active chapter
*	*	*	R4	R3	R2	R1	R0	R9 Active row
*	*	C5	C4	C3	C2	C1	C0	R10 Active column
D7 (R/W)	D6 (R/W)	D5 (R/W)	D4 (R/W)	D3 (R/W)	D2 (R/W)	D1 (R/W)	D0 (R/W)	R11A Active data
60Hz	0	0	0	0	0	0	VCS signal quality	R11B Status
*	*	EROD	A1	A0	*	*	*	R12 Page request address

\* Reserved register bits : must be set to 0

REFRESH ON DISPLAY FUNCTION

This function allows independently to fill the memory using 3 acquisition circuits when the 4th one refreshes the displayed page.

When EROD (D5 of Reg. 12) is 0, refresh on display function is not active. Four teletext pages are filled into memory corresponding to addresses of acquisition registers.

Two blocks of 8 pages are selected with A3 (D7 of Reg. 2)

Upper or lower bank of 4 pages is selected with A2 (D6 of Reg. 2).

Acquisition circuits are selected with A1/A0 (D5/D4 of Reg. 2). This 2 bits also determine the 1KByte of RAM (the chapter) allocated to each acquisition

circuit.

When EROD = 1, refresh on display function is active.

3 acquisition circuits store pages as described above. The 4th one stores data into the current displayed chapter. The chapter is selected with addresses A3/A2/A1/A0 (D3/D2/D1/D0 of Reg. 4). Notice that A1/A0 (D1/D0 of Reg. 4) give the circuit number to be used to refresh this displayed chapter. That means A1/A0 of refresh on display function (D4/D3 of Reg. 12) have to be written identical to A1/A0 (D1/D0 of Reg. 4), as A2 of acquisition circuit (D6 of Reg. 2) has to be identical to A2 of displayed chapter (D2 of Reg. 4).

REGISTER FUNCTIONS

Register	Function	Bit(s)	Description
R0 Address 00H	R11 addressing and pin functions control	SEL 11B (D0)	Selection of register 11B (D0 = 1) or 11A(D0 = 0)
		TC (D1)	Test bit, must be cleared in the normal working mode
		EVEN OFF (D2)	Control of ODD/EVEN pin : EVEN signal output (D2 = 0) or grounded (D2 = 1)
R1 Address 01H	Operating mode controls	T1 T0 0 0 0 1 1 0 1 1	312/313 line MIX - mode with interlace 312/313 line TEXT - mode without interlace 312/312 line Terminal mode without interlace External synchronization TCS/SCS is an input
		TCS ON (D2)	D2 = 1, TCS output on Pin $\overline{TCS/SCS}$ D2 = 0, SCS input on Pin TCS/SCS
		$\overline{DEW}$ / FULLFIELD (D3)	Selection of field flyback mode or full channel mode (D3 = 1)
		GHOST ROW ENABLE (D4)	Selection of ghost row mode (D4 = 1)
		ACQUISITION ON / OFF (D5)	Control of acquisition operation (D5 = 0 enables acquisition)
		$\overline{7\text{ bits + parity or }8\text{ bits without parity}}$ (D6)	Selection of received data format either 7 bits with parity (D6 = 0) or 8 bits without parity (D6 = 1).
R2 Address 02H	Addressing information for a page request	TA (D7)	Test bit, must be cleared in the normal working mode
		SC0, SC1, SC2 (D0, D1, D2)	Address the first column of the on chip page request RAM to be written.
		TB (D3)	Test bit, must be cleared in the normal working mode.
		A0, A1 (D4, D5)	Address a group of four consecutive pages currently used for data acquisition;
		A2 (D6)	Address of one of the two groups of four pages for acquisition in normal mode.
R3 Address 03H	Data relative to the requested page (see Table 3)	A3 (D7)	Block select: D7 = 0 internal memory, D7 = 1 external memory
		PRD0 - PRD4 (D0 - D4)	Written data in the page request RAM, starting with the columns addressed by SC0,SC1,SC2.
		A0, ... A3 (D0, ... D3)	These 4 bits correspond to the logical states of the 4 address lines (A10, ... A13) during memory read cycles.
		R4 Address 04H	Selection of one of 16 pages to display
R5 Address 05H	Display control for normal operation	PON (D0, D1)	Picture on (IN: D0, OUT: D1)
		TEXT (D2, D3)	Text on (IN: D2, OUT: D3)
		$\overline{COR}$ (D4, D5)	Contrast reduction on (IN: D4, OUT: D5)
		BKGND (D6, D7)	Background colour on (IN: D6, OUT: D7)
		IN / OUT	Enable inside/outside the box
R6 Address 06H	Display control for news-flash subtitle generation	See R5	See R5
R7 Address 07H	Display mode	BOX ON 0, 1-23,24 (D0, D1, D2)	The "boxing" function is enabled on row 0,1-23 and 24 by D0, D1 and D2 set to one.
		$\overline{TOP/BOTTOM}$ Single/Double Height (D4/D3)	X0 = Normal 01 = double height Rows 0 to 11 11 = double height Rows 12 to 23
		Conceal/Reveal (D5)	Conceal Reveal Function
		Cursor ON/OFF (D6)	Cursor position given by row/column value of R9/R10
		$\overline{STATUS\ ROW\ BTM / TOP}$ (D7)	The 25th row is displayed before the "Main text Area" (lines 0-23) or after (D7 = 0).

5345-10.TBL



## REGISTER FUNCTIONS (continued)

Register	Function	Bit(s)	Description
R8 to R11A Address 08H to 0BH*	Active chapter address (R8), active row address (R9), active column address (R10). Data contained in R11A read (written) from (to) memory by microprocessor via I <sup>2</sup> C.		
R11B Address 0BH*	Status	VCS Signal Quality (D0)	Good VCS quality signal detected (D0 = 1) or disturbed (D0 = 0)
		60Hz (D7)	VCS received with 60Hz frequency (D7 = 1) or 50Hz (D7 = 0). Only valid when VCS is good (D0 = 1)
R12 Address 0CH	Page request address	A0, A1 (D3, D4)	A0, A1 addresses of displayed page to refresh when using refresh on display function
		EROD (D5)	Enable refresh on displayed page function when = 1 normal acquisition storage if EROD = 0

\* Reading of R11A or R11B is determined by register 0, bit D0. Nevertheless, write operation is always performed on R11A register.

Table 3 : Register R3

START COLUMN	PRD4	PRD3	PRD2	PRD1	PRD0
0	Do care magazine	HOLD	MAG2	MAG1	MAG0
1	Do care page tens	PT3	PT2	PT1	PT0
2	Do care page units	PU3	PU2	PU1	PU0
3	Do care hours tens	X	X	HT1	HT0
4	Do care hours units	HU3	HU2	HU1	HU0
5	Do care minutes tens	X	MT2	MT1	MT0
6	Do care minutes units	MU3	MU2	MU1	MU0

The abbreviations have the same significance as in Table 1 with the exception of the "DO CARE" entries. It is only when this bit is "1" that the corresponding digit is taken into consideration on page request. For example, a page defined as "normal" or one defined as "timed" may be selected.  
If "HOLD" is low the page is held. The addressing of successive bytes via the I<sup>2</sup>C bus is automatic.

## CHARACTER SETS

The complete character set with 8-bit decoding is given in Tables 4a, 4b and 4c.

Characters in columns 0 and 1 are normally displayed as blanks. Black dots represent the character shape whereas white dots represent the background.

Each character can be identified by a pair of corre-

sponding row and column integers : for example the character "3" may be indicated by 3/3.

A rectangle may be represented as follows :

The characters 8/6, 8/7, 9/5, 9/7 are used as special characters, always in conjunction with 8/5.

The 13 national characters are placed in columns with bit 8 = 0.

Table 4a : Complete character set (with 8 bit codes) - West European Languages (STV5345)

B	T	S	b <sub>7</sub>	b <sub>6</sub>	b <sub>5</sub>	b <sub>4</sub>	b <sub>3</sub>	b <sub>2</sub>	b <sub>1</sub>	column	1	2	2a	3	3a	4	5	6	6a	7	7a	8	9	12	13	14	15
0 0 0 0	0 0 0 0	0 0 0 0	0	0	0	0	0	0	0	0	alphanumerics black	graphics black		0 or 1	0	S	P	°					Q	E	é	í	Á
0 0 0 1	0 0 0 1	0 0 0 1	0	0	0	0	0	0	0	1	alphanumerics red	graphics red		0 or 1	0	A	Q	a				1	é	é	é	í	Á
0 0 1 0	0 0 1 0	0 0 1 0	0	0	0	0	0	0	0	2	alphanumerics green	graphics green		0 or 1	0	B	R	b				2	é	é	é	í	Á
0 0 1 1	0 0 1 1	0 0 1 1	0	0	0	0	0	0	0	3	alphanumerics yellow	graphics yellow		0 or 1	0	C	S	c				3	é	é	é	í	Á
0 1 0 0	0 1 0 0	0 1 0 0	0	0	0	0	0	0	0	4	alphanumerics blue	graphics blue		0 or 1	0	D	T	d				4	é	é	é	í	Á
0 1 0 1	0 1 0 1	0 1 0 1	0	0	0	0	0	0	0	5	alphanumerics magenta	graphics magenta		0 or 1	0	E	U	e				5	é	é	é	í	Á
0 1 1 0	0 1 1 0	0 1 1 0	0	0	0	0	0	0	0	6	alphanumerics cyan	graphics cyan		0 or 1	0	F	V	f				6	é	é	é	í	Á
0 1 1 1	0 1 1 1	0 1 1 1	0	0	0	0	0	0	0	7	alphanumerics white	graphics white		0 or 1	0	G	W	g				7	é	é	é	í	Á
1 0 0 0	1 0 0 0	1 0 0 0	0	0	0	0	0	0	0	8	flash	conceal display		0 or 1	0	H	X	h				8	é	é	é	í	Á
1 0 0 1	1 0 0 1	1 0 0 1	0	0	0	0	0	0	0	9	steady	continuous graphics		0 or 1	0	I	Y	i				9	é	é	é	í	Á
1 0 1 0	1 0 1 0	1 0 1 0	0	0	0	0	0	0	0	10	end box	separated graphics		0 or 1	0	J	Z	j				10	é	é	é	í	Á
1 0 1 1	1 0 1 1	1 0 1 1	0	0	0	0	0	0	0	11	start box	ESC		0 or 1	0	K	á	k				11	é	é	é	í	Á
1 1 0 0	1 1 0 0	1 1 0 0	0	0	0	0	0	0	0	12	normal height	black background		0 or 1	0	L	ö	l				12	é	é	é	í	Á
1 1 0 1	1 1 0 1	1 1 0 1	0	0	0	0	0	0	0	13	double height	new background		0 or 1	0	M	ü	m				13	é	é	é	í	Á
1 1 1 0	1 1 1 0	1 1 1 0	0	0	0	0	0	0	0	14	SO	hold graphics		0 or 1	0	N	ç	n				14	é	é	é	í	Á
1 1 1 1	1 1 1 1	1 1 1 1	0	0	0	0	0	0	0	15	SI	release graphics		0 or 1	0	O	¸	o				15	é	é	é	í	Á

Case using C12 C13 C14 = 001 (German Set)

\* These control characters are reserved for compatibility with other data codes.  
 \*\* These control characters are presumed before each row begins

5345-14.EPS



Table 4c : Complete character set (with 8 bit codes) - Turkish European Languages (STV5345/T)

B	T	S	b <sub>4</sub>	b <sub>3</sub>	b <sub>2</sub>	b <sub>1</sub>	column	0	1	2	2a	3	3a	4	5	6	6a	7	7a	8	9	12	13	14	15
0 0 0 0	0 0 0 0	0 0 0 0	0 0 0 0	0 0 0 0	0 0 0 0	0 0 0 0	alphanumerics black	alphanumerics black	alphanumerics red	alphanumerics green	alphanumerics yellow	alphanumerics blue	alphanumerics magenta	alphanumerics cyan	alphanumerics white	flash	steady	end box	start box	normal height	double height	SO	SI		
0 0 0 1	0 0 0 1	0 0 0 1	0 0 0 1	0 0 0 1	0 0 0 1	0 0 0 1	alphanumerics red	alphanumerics red	alphanumerics green	alphanumerics yellow	alphanumerics blue	alphanumerics magenta	alphanumerics cyan	alphanumerics white	conceal display	continuous graphics	separated graphics	ESC	ESC	black background	new background	hold graphics	release graphics		
0 0 1 0	0 0 1 0	0 0 1 0	0 0 1 0	0 0 1 0	0 0 1 0	0 0 1 0	alphanumerics green	alphanumerics green	alphanumerics yellow	alphanumerics blue	alphanumerics magenta	alphanumerics cyan	alphanumerics white	conceal display	continuous graphics	separated graphics	ESC	ESC	black background	new background	hold graphics	release graphics			
0 0 1 1	0 0 1 1	0 0 1 1	0 0 1 1	0 0 1 1	0 0 1 1	0 0 1 1	alphanumerics yellow	alphanumerics yellow	alphanumerics blue	alphanumerics magenta	alphanumerics cyan	alphanumerics white	conceal display	continuous graphics	separated graphics	ESC	ESC	black background	new background	hold graphics	release graphics				
0 1 0 0	0 1 0 0	0 1 0 0	0 1 0 0	0 1 0 0	0 1 0 0	0 1 0 0	alphanumerics blue	alphanumerics blue	alphanumerics magenta	alphanumerics cyan	alphanumerics white	conceal display	continuous graphics	separated graphics	ESC	ESC	black background	new background	hold graphics	release graphics					
0 1 0 1	0 1 0 1	0 1 0 1	0 1 0 1	0 1 0 1	0 1 0 1	0 1 0 1	alphanumerics magenta	alphanumerics magenta	alphanumerics cyan	alphanumerics white	conceal display	continuous graphics	separated graphics	ESC	ESC	black background	new background	hold graphics	release graphics						
0 1 1 0	0 1 1 0	0 1 1 0	0 1 1 0	0 1 1 0	0 1 1 0	0 1 1 0	alphanumerics cyan	alphanumerics cyan	alphanumerics white	conceal display	continuous graphics	separated graphics	ESC	ESC	black background	new background	hold graphics	release graphics							
0 1 1 1	0 1 1 1	0 1 1 1	0 1 1 1	0 1 1 1	0 1 1 1	0 1 1 1	alphanumerics white	alphanumerics white	conceal display	continuous graphics	separated graphics	ESC	ESC	black background	new background	hold graphics	release graphics								
1 0 0 0	1 0 0 0	1 0 0 0	1 0 0 0	1 0 0 0	1 0 0 0	1 0 0 0	flash	flash	conceal display	continuous graphics	separated graphics	ESC	ESC	black background	new background	hold graphics	release graphics								
1 0 0 1	1 0 0 1	1 0 0 1	1 0 0 1	1 0 0 1	1 0 0 1	1 0 0 1	steady	steady	conceal display	continuous graphics	separated graphics	ESC	ESC	black background	new background	hold graphics	release graphics								
1 0 1 0	1 0 1 0	1 0 1 0	1 0 1 0	1 0 1 0	1 0 1 0	1 0 1 0	end box	end box	conceal display	continuous graphics	separated graphics	ESC	ESC	black background	new background	hold graphics	release graphics								
1 0 1 1	1 0 1 1	1 0 1 1	1 0 1 1	1 0 1 1	1 0 1 1	1 0 1 1	start box	start box	conceal display	continuous graphics	separated graphics	ESC	ESC	black background	new background	hold graphics	release graphics								
1 1 0 0	1 1 0 0	1 1 0 0	1 1 0 0	1 1 0 0	1 1 0 0	1 1 0 0	normal height	normal height	conceal display	continuous graphics	separated graphics	ESC	ESC	black background	new background	hold graphics	release graphics								
1 1 0 1	1 1 0 1	1 1 0 1	1 1 0 1	1 1 0 1	1 1 0 1	1 1 0 1	double height	double height	conceal display	continuous graphics	separated graphics	ESC	ESC	black background	new background	hold graphics	release graphics								
1 1 1 0	1 1 1 0	1 1 1 0	1 1 1 0	1 1 1 0	1 1 1 0	1 1 1 0	SO	SO	conceal display	continuous graphics	separated graphics	ESC	ESC	black background	new background	hold graphics	release graphics								
1 1 1 1	1 1 1 1	1 1 1 1	1 1 1 1	1 1 1 1	1 1 1 1	1 1 1 1	SI	SI	conceal display	continuous graphics	separated graphics	ESC	ESC	black background	new background	hold graphics	release graphics								

Case using C12 C13 C14 = 001 (German Set)

\* These control characters are reserved for compatibility with other data codes.  
 \*\* These control characters are presumed before each row begins

5345-16.EPS

The basic set of the 96 characters is shown in Table 5. The location of the 13 national characters

are shown in Table 5 whilst full national character sets are depicted in Tables 6, 7 and 8.

**Table 5 :** Basic character set.

2/0		3/0		4/0	National Character	5/0		6/0	National Character	7/0	
2/1		3/1		4/1		5/1		6/1		7/1	
2/2		3/2		4/2		5/2		6/2		7/2	
2/3	National Character	3/3		4/3		5/3		6/3		7/3	
2/4	National Character	3/4		4/4		5/4		6/4		7/4	
2/5		3/5		4/5		5/5		6/5		7/5	
2/6		3/6		4/6		5/6		6/6		7/6	
2/7		3/7		4/7		5/7		6/7		7/7	
2/8		3/8		4/8		5/8		6/8		7/8	
2/9		3/9		4/9		5/9		6/9		7/9	
2/10		3/10		4/10		5/10		6/10		7/10	
2/11		3/11		4/11		5/11	National Character	6/11		7/11	National Character
2/12		3/12		4/12		5/12	National Character	6/12		7/12	National Character
2/13		3/13		4/13		5/13	National Character	6/13		7/13	National Character
2/14		3/14		4/14		5/14	National Character	6/14		7/14	National Character
2/15		3/15		4/15		5/15	National Character	6/15		7/15	

5345-17.EPS

**Table 6 :** Character Set for STV5345 West European Languages

LANGUAGE	PHCB (1)						CHARACTER POSITION (COLUMN/ROW)													
	C12	C13	C14	2/3	2/4	4/0	5/11	5/12	5/13	5/14	5/15	6/0	7/11	7/12	7/13	7/14				
ENGLISH	0	0	0	0	0	0	0	0	0	0	0	0	0	0	0	0				
GERMAN	0	0	1	0	0	0	0	0	0	0	0	0	0	0	0	0				
SWEDISH	0	1	0	0	0	0	0	0	0	0	0	0	0	0	0	0				
ITALIAN	0	1	1	0	0	0	0	0	0	0	0	0	0	0	0	0				
FRENCH	1	0	0	0	0	0	0	0	0	0	0	0	0	0	0	0				
SPANISH	1	0	1	0	0	0	0	0	0	0	0	0	0	0	0	0				

5345-18.EPS

**Note 1 :** Where PHCB are the Page Header Control bits. Other Combinations default to English. Only the above characters change with the PHCB. All others characters in the basic set are shown in Table 5.

**Table 7 :** Character Set for STV5345/H East European Languages

LANGUAGE	PHCB (1)						CHARACTER POSITION (COLUMN/ROW)													
	C12	C13	C14	2/3	2/4	4/0	5/11	5/12	5/13	5/14	5/15	6/0	7/11	7/12	7/13	7/14				
POLISH	0	0	0	0	0	0	0	0	0	0	0	0	0	0	0	0				
GERMAN	0	0	1	0	0	0	0	0	0	0	0	0	0	0	0	0				
SWEDISH	0	1	0	0	0	0	0	0	0	0	0	0	0	0	0	0				
SERBO-CROAT	1	0	1	0	0	0	0	0	0	0	0	0	0	0	0	0				
CZECHOSLOVAK	1	1	0	0	0	0	0	0	0	0	0	0	0	0	0	0				
RUMANIAN	1	1	1	0	0	0	0	0	0	0	0	0	0	0	0	0				

5345-18.EPS

**Note 1 :** Where PHCB are the Page Header Control bits. Other Combinations default to German. Only the above characters change with the PHCB. All others characters in the basic set are shown in Table 5.

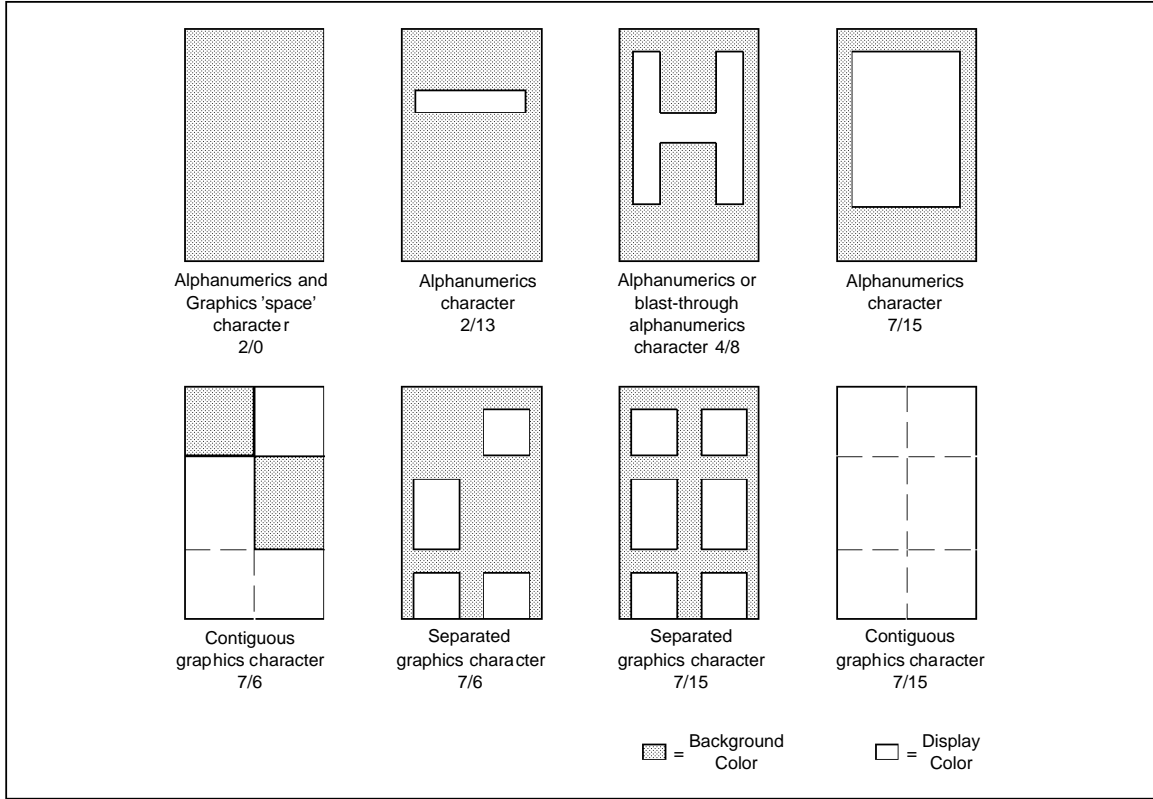
**Table 8 :** Character Set for STV5345/T Turkish European Languages

LANGUAGE	PHCB (1)			CHARACTER POSITION (COLUMN/ROW)												
	C12	C13	C14	2/3	2/4	4/0	5/11	5/12	5/13	5/14	5/15	6/0	7/11	7/12	7/13	7/14
ENGLISH	0	0	0													
GERMAN	0	0	1													
TURKISH	1	1	0													
ITALIAN	0	1	1													
FRENCH	1	0	0													
SPANISH	1	0	1													

5345-20.EPS

**Note 1 :** Where PHCB are the Page Header Control bits. Other Combinations default to Turkish. Only the above characters change with the PHCB. All others characters in the basic set are shown in Table 5.

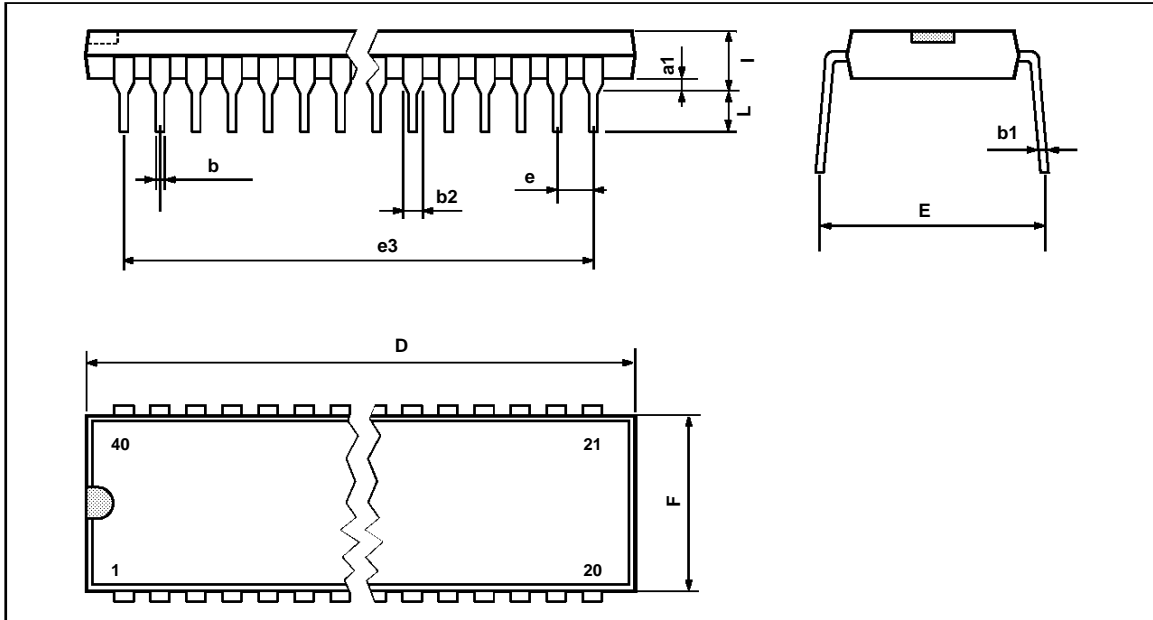
Figure 11 : Character Format



5345-21.EPS



**PACKAGE MECHANICAL DATA**  
40 PINS - PLASTIC DIP



PM-DIP40.EPS

Dimensions	Millimeters			Inches		
	Min.	Typ.	Max.	Min.	Typ.	Max.
a1		0.63			0.025	
b		0.45			0.018	
b1	0.23		0.31	0.009		0.012
b2		1.27			0.050	
D			52.58			2.070
E	15.2		16.68	0.598		0.657
e		2.54			0.100	
e3		48.26			1.900	
F			14.1			0.555
i		4.445			0.175	
L		3.3			0.130	

DIP40.TBL

Information furnished is believed to be accurate and reliable. However, SGS-THOMSON Microelectronics assumes no responsibility for the consequences of use of such information nor for any infringement of patents or other rights of third parties which may result from its use. No licence is granted by implication or otherwise under any patent or patent rights of SGS-THOMSON Microelectronics. Specifications mentioned in this publication are subject to change without notice. This publication supersedes and replaces all information previously supplied. SGS-THOMSON Microelectronics products are not authorized for use as critical components in life support devices or systems without express written approval of SGS-THOMSON Microelectronics.

© 1994 SGS-THOMSON Microelectronics - All Rights Reserved

Purchase of  $\text{I}^2\text{C}$  Components of SGS-THOMSON Microelectronics, conveys a license under the Philips  $\text{I}^2\text{C}$  Patent. Rights to use these components in a  $\text{I}^2\text{C}$  system, is granted provided that the system conforms to the  $\text{I}^2\text{C}$  Standard Specifications as defined by Philips.

SGS-THOMSON Microelectronics GROUP OF COMPANIES

Australia - Brazil - China - France - Germany - Hong Kong - Italy - Japan - Korea - Malaysia - Malta - Morocco  
The Netherlands - Singapore - Spain - Sweden - Switzerland - Taiwan - Thailand - United Kingdom - U.S.A.