

QUAD PREAMPLIFIER FOR DOUBLE CASSETTE TAPE RECORDER

KIA6289N is a Quad pre-amplifier designed for use in record/play back amplifier. It is suitable for double cassette tape recorder. (for Autoreverse)

FEATURES

PLAY BACK AMP

- Built in input select switch.
- Built in equalizer control switch.
- Mixing output, for music selection.

RECORDING AMP

- Built in ALC detector circuit.
- Operating supply voltage range : $V_{CC}=4\sim 13.5V(T_a=25^\circ C)$.

MAXIMUM RATINGS ($T_a=25^\circ C$)

CHARACTERISTIC	SYMBOL	RATING	UNIT
Supply Voltage	V_{CC}	14.5	V
Power Dissipation (Note)	P_D	1200	mW
Operating Temperature	T_{opr}	-20~75	$^\circ C$
Storage Temperature	T_{sig}	-55~150	$^\circ C$

Note : Derated above $T_a=25^\circ C$ in the proportion of 9.6mW for KIA6289N.

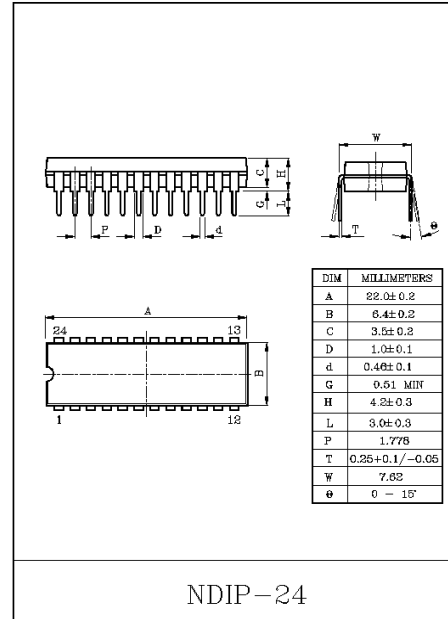

KIA6289N

BLOCK DIAGRAM & TEST CIRCUIT

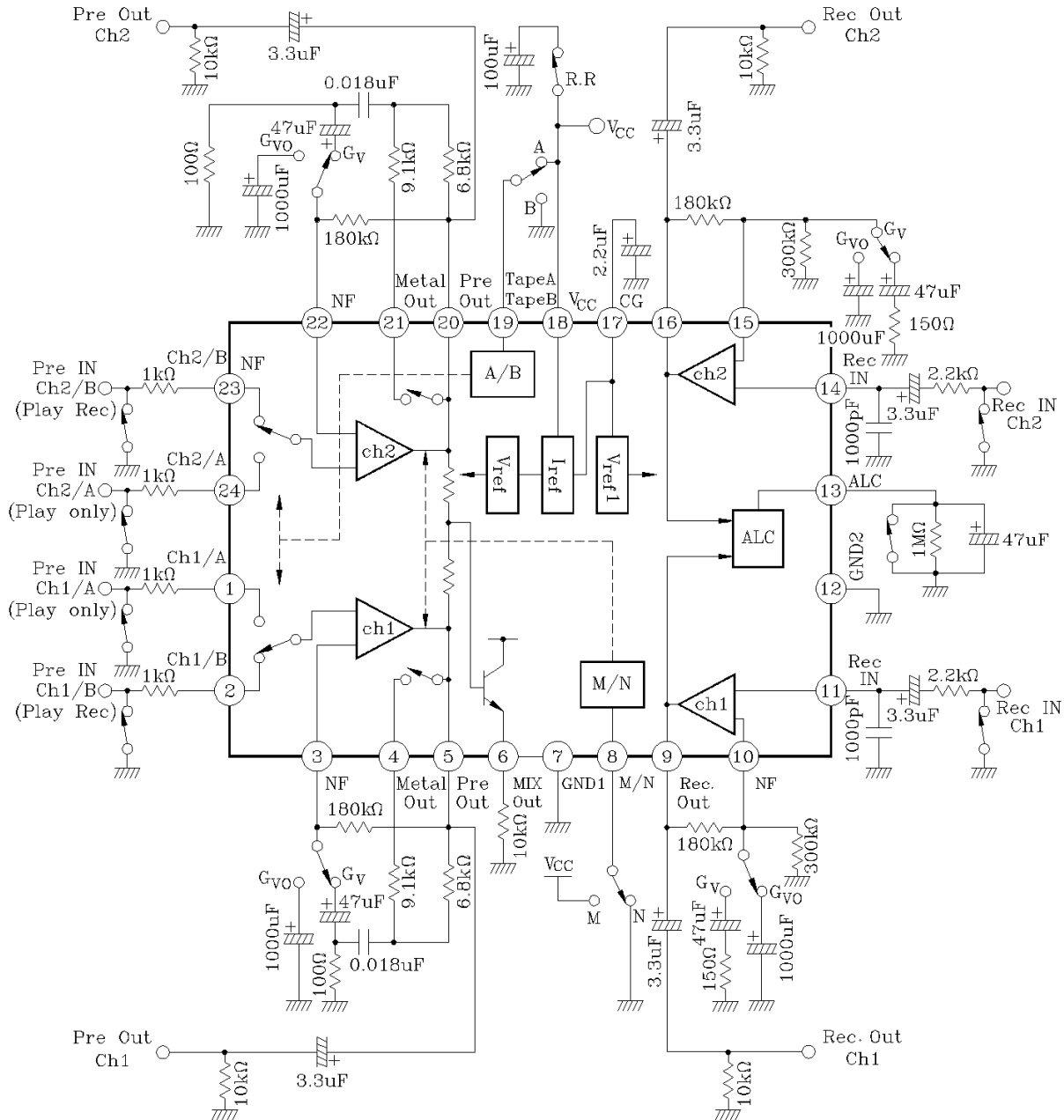

KIA6289N

APPLICATION CIRCUIT

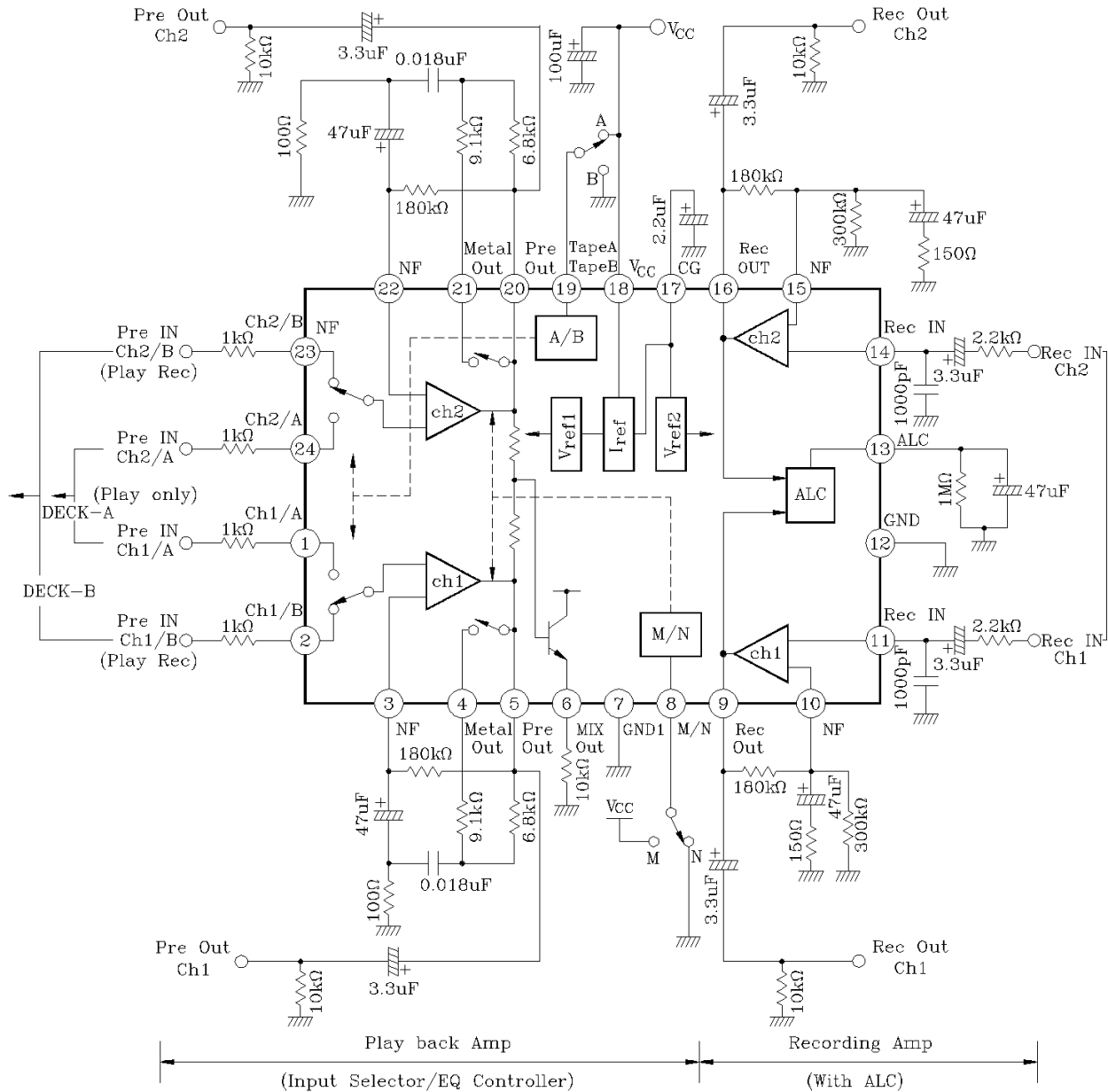

KIA6289N

ELECTRICAL CHARACTERISTICS

(Unless otherwise specified : $V_{CC}=6V$, $f=1kHz$, $T_a=25^{\circ}C$)

CHARACTERISTIC	SYMBOL	TEST CONDITION	MIN.	TYP.	MAX.	UNIT
Quiescent Current	I_{CCQ}	Metal Mode, Rec ON, $V_{IN}=0$	-	13	20	mA
Output Noise Voltage	V_{NO} (Pre)	Normal Mode, $R_g=2.2k\Omega$, $BW=20Hz\sim 20kHz$	-	200	600	μV_{rms}
Total Harmonic Distortion	THD (Pre)	$V_{OUT}=0.2V_{rms}$, $f=1kHz$ Normal Mode	-	0.06	0.2	%
Maximum Output Voltage	V_{OM} (Pre)	THD=1.0%, $f=1kHz$ Normal Mode	0.5	1.0	-	V_{rms}
Open Loop Voltage Gain	G_{VO} (Pre)	$f=1kHz$, $V_{IN}=-95dBm$	70	95	-	dB
Cross Talk	C.T(Ch) (Pre)	$V_{OUT}=0dBm$, $f=1kHz$, $R_g=2.2k\Omega$ Normal Mode	40	60	-	dB
Tape A/Tape B Cross Talk	C.T(IN) (Pre)	$V_{OUT}=0dBm$, $f=1kHz$, $R_g=2.2k\Omega$ Normal Mode	-	66	-	dB
Ripple Rejection Ratio	R.R (Pre)	$V_{RIP}=0dBm$, $f_{RIP}=100Hz$ Normal Mode, $R_g=2.2k\Omega$	-	38	-	dB
Voltage Gain	G_V (Pre)	$V_{IN}=-40dBm$, $f=1kHz$, Normal Mode	-	40	-	dB
Pre Amp→Rec Amp C.T	C.T. (P/R)	$f=1kHz$, $V_{OUT}(\text{Pre})=0dB$, Normal(Pre)	-	53	-	dB
Rec Amp→Pre Amp C.T	C.T. (R/P)	$f=1kHz$, $V_{OUT}(\text{Rec})=0dB$, Normal(Pre)	-	76	-	dB
Output Noise Voltage	$V_{NO}(\text{Rec})$	$R_g=2.2k\Omega$, $BW=20Hz\sim 20kHz$ ALC OFF	-	1.35	2.7	mV_{rms}
Total Harmonics Distortion	THD(Rec)	$f=1kHz$, $V_{OUT}=0.5V_{rms}$, ALC OFF	-	0.37	1.0	%
Maximum Output Voltage	$V_{OM}(\text{Rec})$	THD=1%, $f=1kHz$, ALC OFF	1.2	1.5	-	V_{rms}
Open Loop Voltage Gain	G_{VO}	$f=1kHz$, $V_{IN}=-110dBV$, ALC OFF	80	108	-	dB
ALC Range	R(ACL)	$V_{IN}=-60dBV$, $f=1kHz$	-	52	-	dB
Total Harmonic Distortion (ALC)	THD(ALC)	$V_{IN}=-20dB$, Dual input, $f=1kHz$	-	0.48	1.0	%
ALC Balance	B(ALC)	$V_{IN}=-20dB$, Dual input, $f=1kHz$	-	0	2	dB
ALC Level	V(ALC)	$V_{IN}=-20dBm$, $f=1kHz$	0.75	1.0	1.2	V_{rms}
Ripple Rejection Ratio	R.R(Rec)	$V_{RIP}=0dBm$, $f_{RIP}=100Hz$, $R_g=2.2k\Omega$	-	30	-	dB
Voltage Gain	G_V (Rec)	$f=1kHz$ (FLAT), $V_{IN}=-60dBV$	-	61	-	dB
Cross Talk (ALC OFF)	C.T(ch)	$f=1kHz$, $R_g=2.2k\Omega$, $V_{IN}=-60dBV$	40	54	-	dB
Cross Talk (ALC ON)	C.T(ALC)	$f=1kHz$, $R_g=2.2k\Omega$, $V_{IN}=-20dBm$	40	54	-	dB

KIA6289N

TERMINAL EXPLANATION

NO.	TERMINAL NAME	FUNCTION	EQUIVALENT CIRCUIT
1	TAPE A IN (ch1)	Tape Play Back Input (Play)	
24	TAPE A IN (ch1)		
2	TAPE B IN (ch2)	Tape Play Back Input (Play/Rec)	
23	TAPE B IN (ch2)		
3	PB NF (ch1)	Tape Play Back NF	
22	PB NF (ch2)		
4/21	Metal Out	Play Back Amp Metal Output	
5	Pre Out (ch1)	Play Back Amp Output	
20	Pre Out (ch2)		
6	MIX OUT	Mixing Output	
7	GND	GND	

KIA6289N

NO.	TERMINAL NAME	FUNCTION	EQUIVALENT CIRCUIT
8	Metal/Normal SW	Change Over Switch for Metal Mode and Normal Mode.	
9	Rec Out (Ch1)	Recording Amp Output	
16	Rec Out (Ch2)		
10	Rec NF(Ch1)	Recording Amp NF	
15	Rec NF(Ch2)		
11	Rec IN (Ch1)	Recording Amp Input	
14	Rec IN (Ch2)		
12	GND	GND	

KIA6289N

NO.	TERMINAL NAME	FUNCTION	EQUIVALENT CIRCUIT
13	ALC T.G	Automatic Level Control (ALC) Time Constant Terminal	
17	CG Det.	NF Charge up Circuit Switching Terminal	
19	TAPE A/TAPE B SW	Play Back Amp Input Selector	

KIA6289N

Note :

1. Input Level of Play Amp.

In case that input voltage ($V_{IN} = -30\text{dBm}$) is applied to A-Head at same time on a set, use A-Head for reproducing only and, B-Head for recording or reproducing.
In case that the over-voltage is applied to A-Head and B-Head at same time, the Transistor Q3, Q4 are made a saturation condition and NF condenser is discharged by Base-current of Q3, Q4 and the output DC voltage of pin ③/22 are raised.
In case of the high input, use B-Head, because of building in the diode against saturation on Q4.

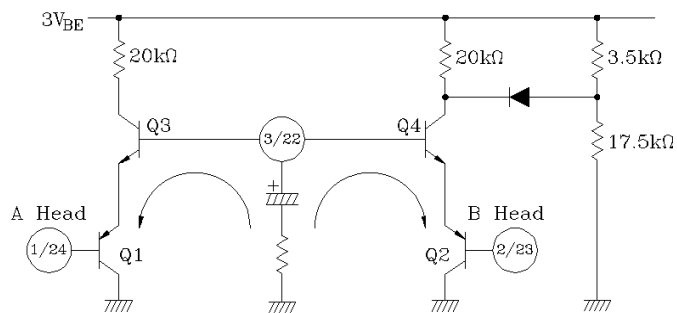

2. Power Source Line

In case of including the Ripple on the power source line, stabilize by using a transistor as following figure.

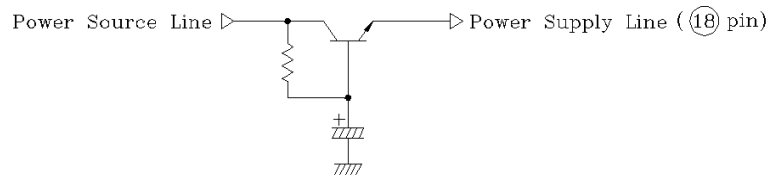

KIA6289N

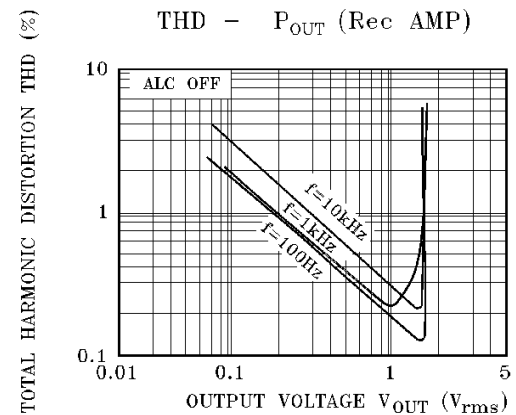
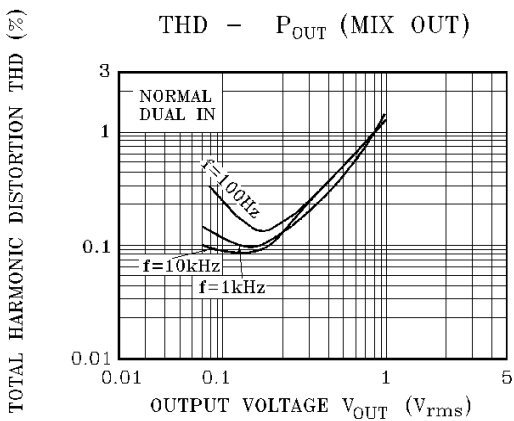
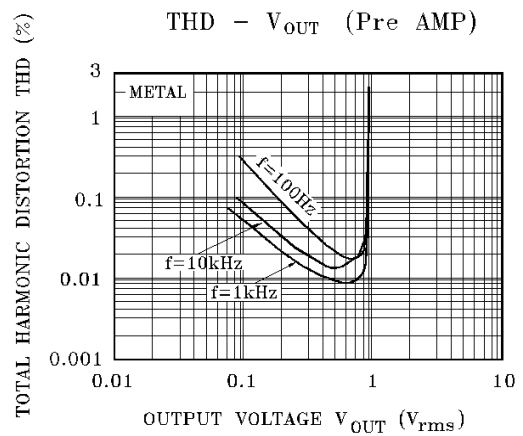
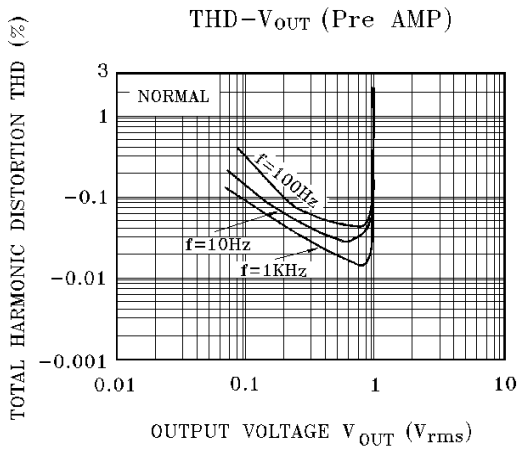
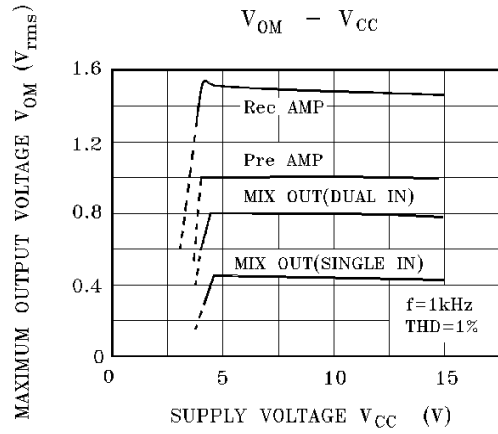
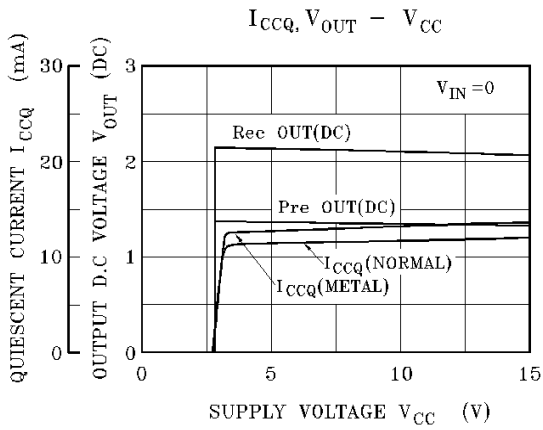

KIA6289N

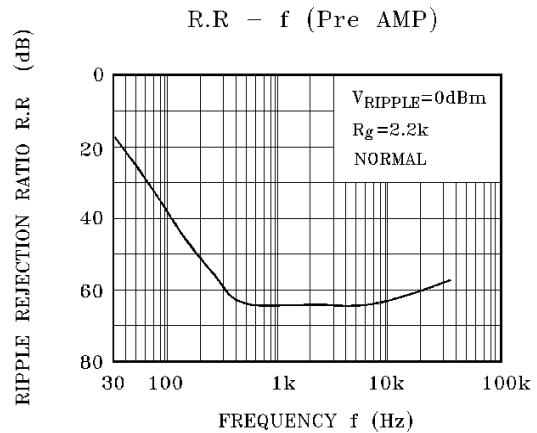
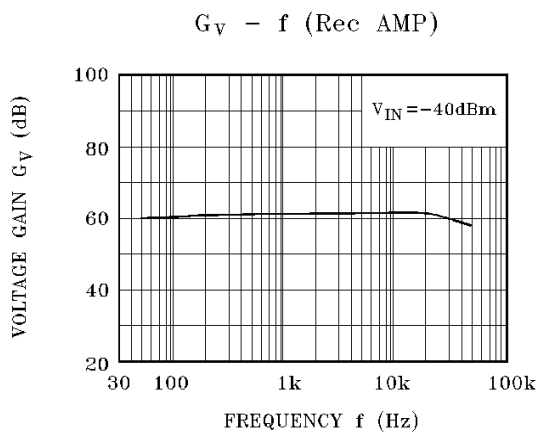
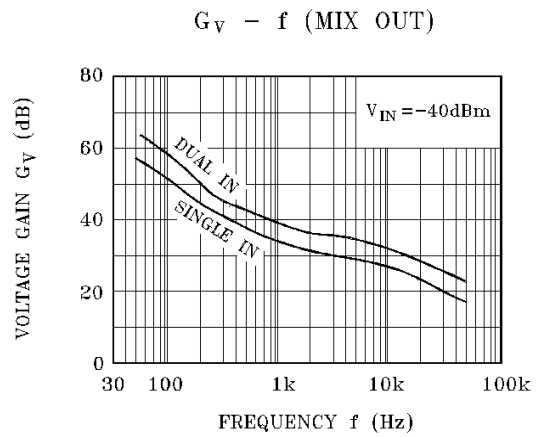
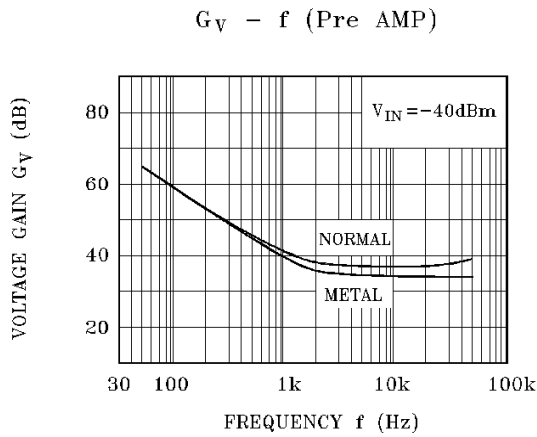
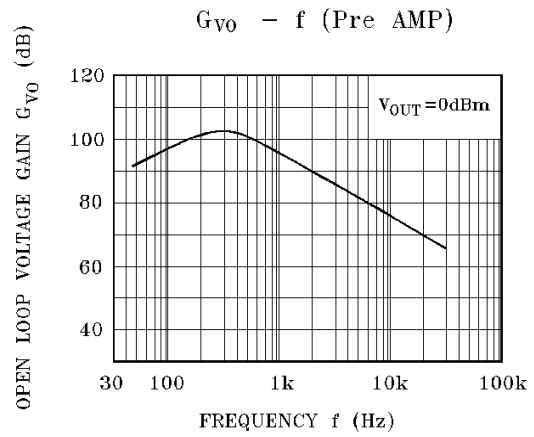
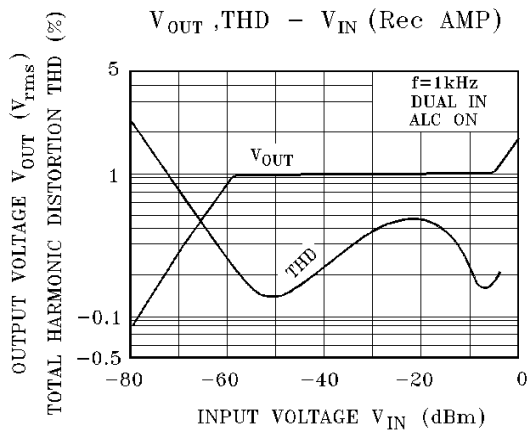

KIA6289N

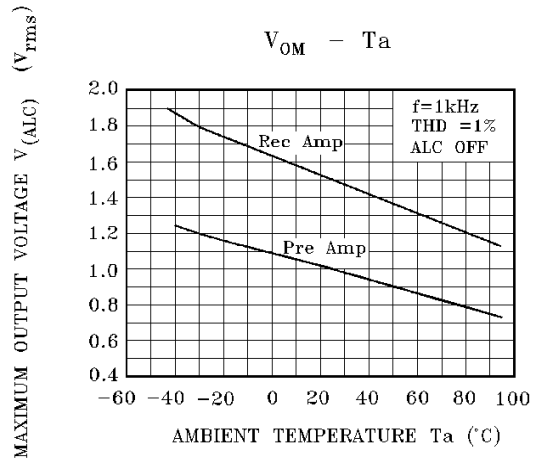
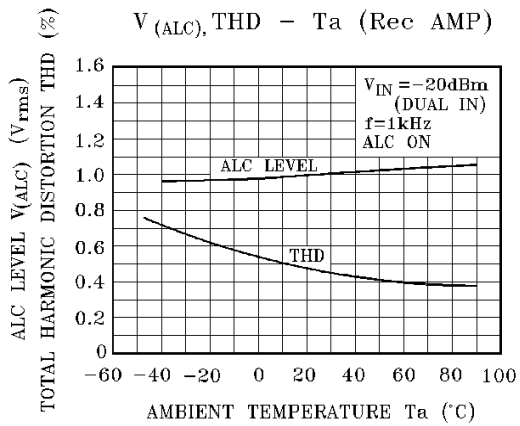
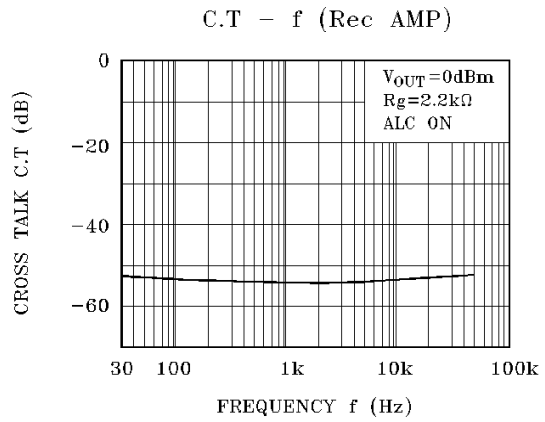
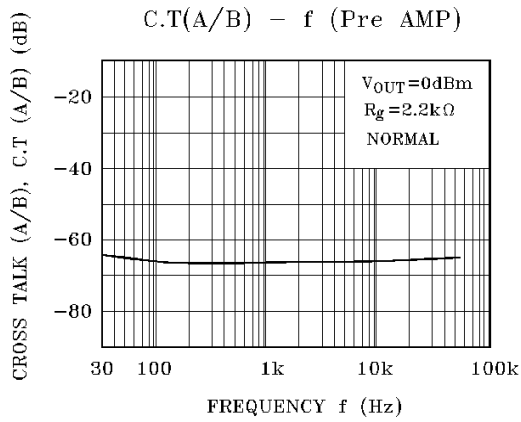
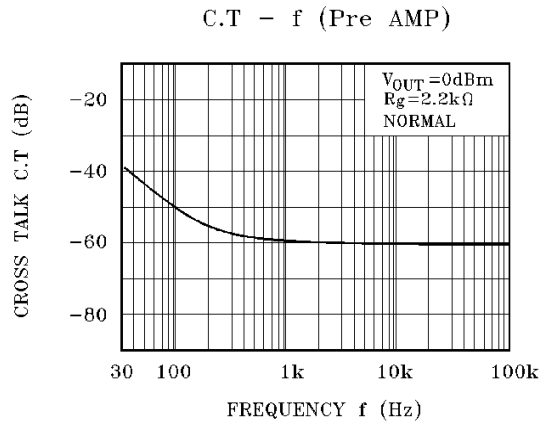
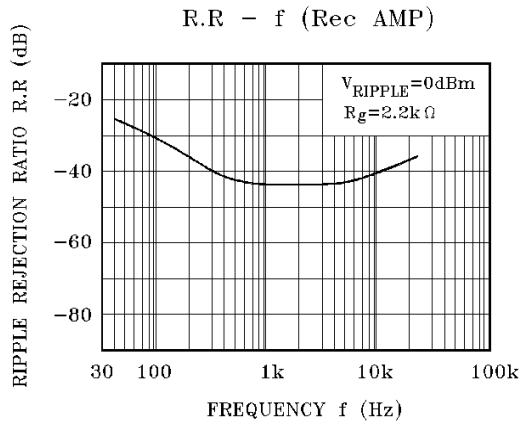

KIA6289N

