

ADM223/ADM230L-ADM241L

FEATURES

- Single 5 V Power Supply
- Meets All EIA-232-E and V.28 Specifications
- 120 kB/s Data Rate
- On-Board DC-DC Converters
- ±9 V Output Swing with +5 V Supply
- Small 1 μF Capacitors
- Low Power Shutdown ≤1 μA
- Receivers Active in Shutdown (ADM223)
- ESD > 2 kV
- ±30 V Receiver Input Levels
- Latch-Up FREE
- Plug-In Upgrade for MAX223/230-241
- Plug-In Upgrade for AD230-AD241

APPLICATIONS

- Computers
- Peripherals
- Modems
- Printers
- Instruments

GENERAL DESCRIPTION

The ADM2xx family of line drivers/receivers is intended for all EIA-232-E and V.28 communications interfaces, especially in applications where ±12 V is not available. The ADM223, ADM230L, ADM235L, ADM236L and ADM241L feature a low power shutdown mode that reduces power dissipation to less than 5 μW, making them ideally suited for battery powered equipment. Two receivers remain enabled during shutdown on the ADM223. The ADM233L and ADM235L do not require any external components and are particularly useful in applications where printed circuit board space is critical.

ADM232L TYPICAL OPERATING CIRCUIT

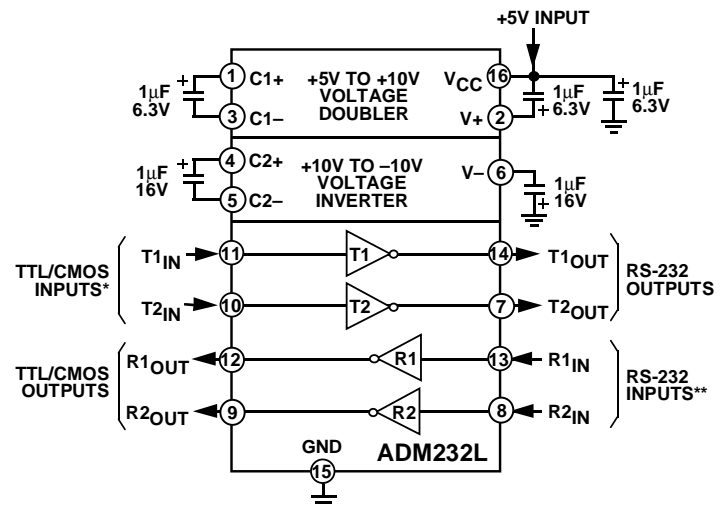

- *INTERNAL 400kΩ PULL-UP RESISTOR ON EACH TTL/CMOS INPUT
- **INTERNAL 5kΩ PULL-DOWN RESISTOR ON EACH RS-232 INPUT

All members of the ADM230L family, except the ADM231L and the ADM239L, include two internal charge pump voltage converters that allow operation from a single +5 V supply. These converters convert the +5 V input power to the ±10 V required for RS-232 output levels. The ADM231L and ADM239L are designed to operate from +5 V and +12 V supplies. An internal +12 V to -12 V charge pump voltage converter generates the -12 V supply.

The ADM2xxL is an enhanced upgrade for the AD2xx family featuring lower power consumption, faster slew rate and operation with smaller (1 μF) capacitors.

Table I. Selection Table

Part Number	Power Supply Voltage	No. of RS-232 Drivers	No. of RS-232 Receivers	External Capacitors	Low Power Shutdown (SD)	TTL Three-State EN	No. of Pins
ADM223	+5 V	4	5	4	Yes (\overline{SD})	Yes (EN)	28
ADM230L	+5 V	5	0	4	Yes	No	20
ADM231L	+5 V & +7.5 V to +13.2 V	2	2	2	No	No	14
ADM232L	+5 V	2	2	4	No	No	16
ADM233L	+5 V	2	2	None	No	No	20
ADM234L	+5 V	4	0	4	No	No	16
ADM235L	+5 V	5	5	None	Yes	Yes	24
ADM236L	+5 V	4	3	4	Yes	Yes	24
ADM237L	+5 V	5	3	4	No	No	24
ADM238L	+5 V	4	4	4	No	No	24
ADM239L	+5 V & +7.5 V to +13.2 V	3	5	2	No	Yes	24
ADM241L	+5 V	4	5	4	Yes	Yes	28

REV. 0

Information furnished by Analog Devices is believed to be accurate and reliable. However, no responsibility is assumed by Analog Devices for its use, nor for any infringements of patents or other rights of third parties which may result from its use. No license is granted by implication or otherwise under any patent or patent rights of Analog Devices.

One Technology Way, P.O. Box 9106, Norwood, MA 02062-9106, U.S.A.
 Tel: 617/329-4700 World Wide Web Site: <http://www.analog.com>
 Fax: 617/326-8703 © Analog Devices, Inc., 1997

ADM223/ADM230L-ADM241L-SPECIFICATIONS $V_{CC} = +5\text{ V} \pm 10\%$ (ADM223, 31L, 32L, 34L, 36L, 38L, 39L, 41L);

$V_{CC} = +5\text{ V} \pm 5\%$ (ADM230L, 33L, 35L, 37L); $V_{+} = 7.5\text{ V}$ to 13.2 V (ADM231L & ADM239L); $C1-C4 = 1.0\ \mu\text{F}$ Ceramic. All Specifications T_{MIN} to T_{MAX} unless otherwise noted.)

Parameter	Min	Typ	Max	Units	Test Conditions/Comments
Output Voltage Swing	± 5	± 9		Volts	All Transmitter Outputs Loaded with 3 k Ω to Ground
V_{CC} Power Supply Current		2	3.0	mA	No Load, All $T_{INS} = V_{CC}$ (Except ADM223)
		3.5	6	mA	No Load, All $T_{INS} = \text{GND}$
		0.4	1	mA	ADM231L, ADM239L
V_{+} Power Supply Current		1.5	4	mA	No Load, $V_{+} = 12\text{ V}$ ADM231L & ADM239L Only
Shutdown Supply Current		1	5	μA	
Input Logic Threshold Low, V_{INL}			0.8	V	$T_{IN}, \overline{EN}, \overline{SD}, EN, \overline{SD}$
Input Logic Threshold High, V_{INH}	2.0			V	$T_{IN}, \overline{EN}, \overline{SD}, EN, \overline{SD}$
Logic Pull-Up Current		10	25	μA	$T_{IN} = 0\text{ V}$
RS-232 Input Voltage Range	-30		+30	V	
RS-232 Input Threshold Low	0.8	1.2		V	
RS-232 Input Threshold High		1.7	2.4	V	
RS-232 Input Hysteresis	0.2	0.5	1.0	V	
RS-232 Input Resistance	3	5	7	k Ω	
TTL/CMOS Output Voltage Low, V_{OL}			0.4	V	
TTL/CMOS Output Voltage High, V_{OH}	3.5			V	$I_{OUT} = -1.0\text{ mA}$
TTL/CMOS Output Leakage Current		0.05	± 5	μA	$\overline{EN} = V_{CC}, 0\text{ V} \leq R_{OUT} \leq V_{CC}$
Output Enable Time (T_{EN})		250		ns	ADM223, ADM235L, ADM236L, ADM239L, ADM241L (Figure 25. $C_L = 150\text{ pF}$)
Output Disable Time (T_{DIS})		50		ns	ADM223, ADM235L, ADM236L, ADM239L, ADM241L (Figure 25. $R_L = 1\text{ k}\Omega$)
Propagation Delay		0.5		μs	RS-232 to TTL
Instantaneous Slew Rate ¹		25	30	V/ μs	$C_L = 10\text{ pF}, R_L = 3-7\text{ k}\Omega, T_A = +25^{\circ}\text{C}$
Transition Region Slew Rate		5		V/ μs	$R_L = 3\text{ k}\Omega, C_L = 2500\text{ pF}$
Output Resistance	300			Ω	Measured from +3 V to -3 V or -3 V to +3 V
RS-232 Output Short Circuit Current		± 10		mA	$V_{CC} = V_{+} = V_{-} = 0\text{ V}, V_{OUT} = \pm 2\text{ V}$

NOTE

¹Sample tested to ensure compliance.

Specifications subject to change without notice.

ABSOLUTE MAXIMUM RATINGS*

($T_A = 25^{\circ}\text{C}$ unless otherwise noted)

V_{CC}	-0.3 V to +6 V
V_{+}	($V_{CC} - 0.3\text{ V}$) to +14 V
V_{-}	+0.3 V to -14 V
Input Voltages	
T_{IN}	-0.3 V to ($V_{CC} + 0.3\text{ V}$)
R_{IN}	$\pm 30\text{ V}$
Output Voltages	
T_{OUT}	($V_{+}, +0.3\text{ V}$) to ($V_{-}, -0.3\text{ V}$)
R_{OUT}	-0.3 V to ($V_{CC} + 0.3\text{ V}$)
Short Circuit Duration	
T_{OUT}	Continuous
Power Dissipation	
N-14 DIP (Derate 10 mW/ $^{\circ}\text{C}$ above +70 $^{\circ}\text{C}$)	800 mW
N-16 DIP (Derate 10.5 mW/ $^{\circ}\text{C}$ above +70 $^{\circ}\text{C}$)	840 mW
N-20 DIP (Derate 11 mW/ $^{\circ}\text{C}$ above +70 $^{\circ}\text{C}$)	890 mW
N-24 DIP (Derate 13.5 mW/ $^{\circ}\text{C}$ above +70 $^{\circ}\text{C}$)	1000 mW
N-24A DIP (Derate 13.5 mW/ $^{\circ}\text{C}$ above +70 $^{\circ}\text{C}$)	500 mW
R-16 SOIC (Derate 9 mW/ $^{\circ}\text{C}$ above +70 $^{\circ}\text{C}$)	760 mW
R-20 SOIC (Derate 9.5 mW/ $^{\circ}\text{C}$ above +70 $^{\circ}\text{C}$)	800 mW
R-24 SOIC (Derate 12 mW/ $^{\circ}\text{C}$ above +70 $^{\circ}\text{C}$)	850 mW
R-28 SOIC (Derate 12.5 mW/ $^{\circ}\text{C}$ above +70 $^{\circ}\text{C}$)	900 mW
RS-28 SSOP (Derate 10 mW/ $^{\circ}\text{C}$ above +70 $^{\circ}\text{C}$)	900 mW
Q-14 Cerdip (Derate 10 mW/ $^{\circ}\text{C}$ above +70 $^{\circ}\text{C}$)	720 mW
Q-16 Cerdip (Derate 10 mW/ $^{\circ}\text{C}$ above +70 $^{\circ}\text{C}$)	800 mW
Q-20 Cerdip (Derate 11.2 mW/ $^{\circ}\text{C}$ above +70 $^{\circ}\text{C}$)	890 mW
Q-24 Cerdip (Derate 12.5 mW/ $^{\circ}\text{C}$ above +70 $^{\circ}\text{C}$)	1000 mW
D-24 Ceramic (Derate 20 mW/ $^{\circ}\text{C}$ above +70 $^{\circ}\text{C}$)	1000 mW

Thermal Impedance, θ_{JA}

N-14 DIP	140 $^{\circ}\text{C}/\text{W}$
N-16 DIP	135 $^{\circ}\text{C}/\text{W}$
N-20 DIP	125 $^{\circ}\text{C}/\text{W}$
N-24 DIP	120 $^{\circ}\text{C}/\text{W}$
N-24A DIP	110 $^{\circ}\text{C}/\text{W}$
R-16 SOIC	105 $^{\circ}\text{C}/\text{W}$
R-20 SOIC	105 $^{\circ}\text{C}/\text{W}$
R-24 SOIC	85 $^{\circ}\text{C}/\text{W}$
R-28 SOIC	80 $^{\circ}\text{C}/\text{W}$
RS-28 SSOP	100 $^{\circ}\text{C}/\text{W}$
Q-14 Cerdip	105 $^{\circ}\text{C}/\text{W}$
Q-16 Cerdip	100 $^{\circ}\text{C}/\text{W}$
Q-20 Cerdip	100 $^{\circ}\text{C}/\text{W}$
Q-24 Cerdip	55 $^{\circ}\text{C}/\text{W}$
D-24 Ceramic	50 $^{\circ}\text{C}/\text{W}$

Operating Temperature Range

Commercial (J Version)	0 to +70 $^{\circ}\text{C}$
Industrial (A Version)	-40 $^{\circ}\text{C}$ to +85 $^{\circ}\text{C}$
Storage Temperature Range	-65 $^{\circ}\text{C}$ to +150 $^{\circ}\text{C}$
Lead Temperature, Soldering	+300 $^{\circ}\text{C}$
Vapour Phase (60 sec)	+215 $^{\circ}\text{C}$
Infrared (15 sec)	+220 $^{\circ}\text{C}$
ESD Rating	>2000 V

*This is a stress rating only and functional operation of the device at these or any other conditions above those indicated in the operational sections of this specification is not implied. Exposure to absolute maximum rating conditions for extended periods of time may affect reliability.

ORDERING GUIDE

Model	Temperature Range	Package Option*	Model	Temperature Range	Package Option*	Model	Temperature Range	Package Option*
ADM223			ADM230L			ADM231L		
ADM223AR	–40°C to +85°C	R-28	ADM230LJN	0°C to +70°C	N-20	ADM231LJN	0°C to +70°C	N-14
ADM223ARS	–40°C to +85°C	RS-28	ADM230LJR	0°C to +70°C	R-20	ADM231LJR	0°C to +70°C	R-16
			ADM230LAN	–40°C to +85°C	N-20	ADM231LAN	–40°C to +85°C	N-14
			ADM230LAR	–40°C to +85°C	R-20	ADM231LAR	–40°C to +85°C	R-16
			ADM230LAQ	–40°C to +85°C	Q-20	ADM231LAQ	–40°C to +85°C	Q-14
ADM232L			ADM233L			ADM234L		
ADM232LJN	0°C to +70°C	N-16	ADM233LJN	0°C to +70°C	N-20	ADM234LJN	0°C to +70°C	N-16
ADM232LJR	0°C to +70°C	R-16	ADM233LAN	–40°C to +85°C	N-20	ADM234LJR	0°C to +70°C	R-16
ADM232LAN	–40°C to +85°C	N-16				ADM234LAN	–40°C to +85°C	N-16
ADM232LAR	–40°C to +85°C	R-16				ADM234LAR	–40°C to +85°C	R-16
ADM232LAQ	–40°C to +85°C	Q-16				ADM234LAQ	–40°C to +85°C	Q-16
ADM235L			ADM236L			ADM237L		
ADM235LJN	0°C to +70°C	N-24A	ADM236LJN	0°C to +70°C	N-24	ADM237LJN	0°C to +70°C	N-24
ADM235LAN	–40°C to +85°C	N-24A	ADM236LJR	0°C to +70°C	R-24	ADM237LJR	0°C to +70°C	R-24
ADM235LAQ	–40°C to +85°C	D-24	ADM236LAN	–40°C to +85°C	N-24	ADM237LAN	–40°C to +85°C	N-24
			ADM236LAR	–40°C to +85°C	R-24	ADM237LAR	–40°C to +85°C	R-24
			ADM236LAQ	–40°C to +85°C	Q-24	ADM237LAQ	–40°C to +85°C	Q-24
ADM238L			ADM239L			ADM241L		
ADM238LJN	0°C to +70°C	N-24	ADM239LJN	0°C to +70°C	N-24	ADM241LJR	0°C to +70°C	R-28
ADM238LJR	0°C to +70°C	R-24	ADM239LJR	0°C to +70°C	R-24	ADM241LAR	–40°C to +85°C	R-28
ADM238LAN	–40°C to +85°C	N-24	ADM239LAN	–40°C to +85°C	N-24	ADM241LJRS	0°C to +70°C	RS-28
ADM238LAR	–40°C to +85°C	R-24	ADM239LAR	–40°C to +85°C	R-24	ADM241LARS	–40°C to +85°C	RS-28
ADM238LAQ	–40°C to +85°C	Q-24	ADM239LAQ	–40°C to +85°C	Q-24			

*D = Ceramic DIP; N = Plastic DIP; Q = Cerdip; R = Small Outline IC (SOIC); RS = Small Shrink Outline Package (SSOP).

CAUTION

ESD (electrostatic discharge) sensitive device. Electrostatic charges as high as 4000 V readily accumulate on the human body and test equipment and can discharge without detection. Although the ADM223/ADM230L–ADM241L features proprietary ESD protection circuitry, permanent damage may occur on devices subjected to high energy electrostatic discharges. Therefore, proper ESD precautions are recommended to avoid performance degradation or loss of functionality.



ADM223/ADM230L-ADM241L

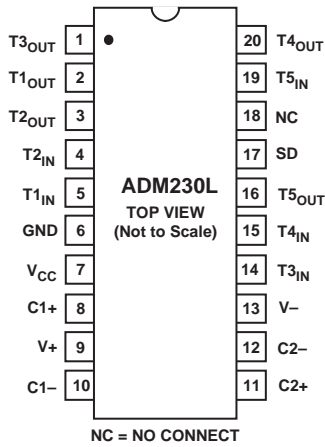
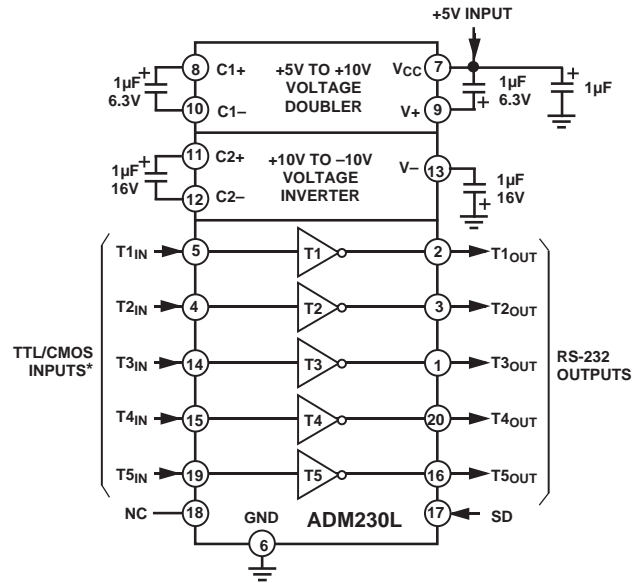

Figure 1. ADM230L DIP/SOIC Pin Configuration



*INTERNAL 400kΩ PULL-UP RESISTOR ON EACH TTL/CMOS INPUT

Figure 2. ADM230L Typical Operating Circuit

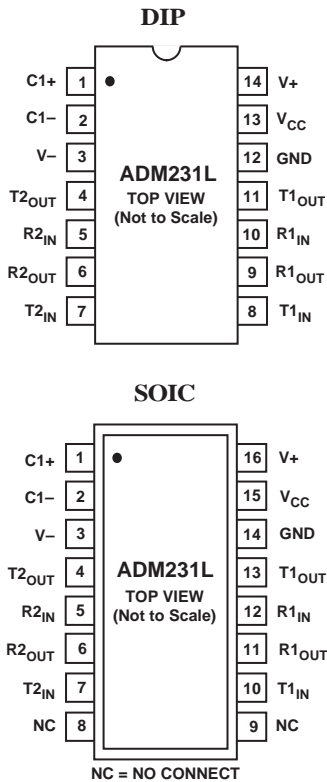
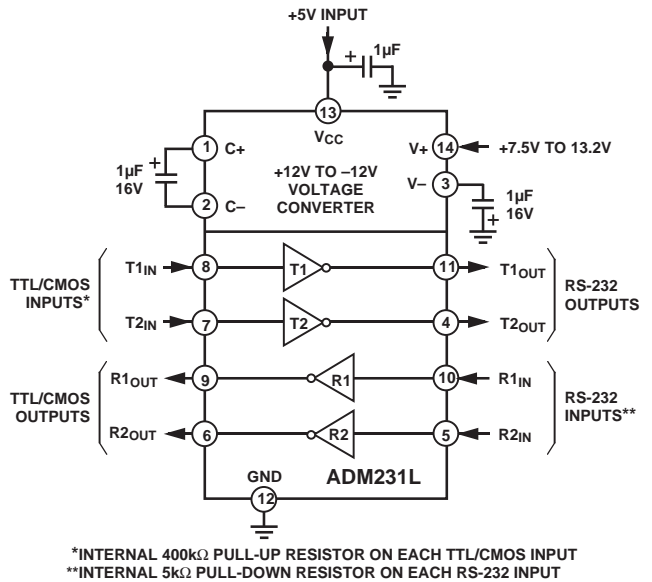

Figure 3. ADM231L DIP & SOIC Pin Configurations



*INTERNAL 400kΩ PULL-UP RESISTOR ON EACH TTL/CMOS INPUT

**INTERNAL 5kΩ PULL-DOWN RESISTOR ON EACH RS-232 INPUT

Figure 4. ADM231L Typical Operating Circuit (DIP Pinout)

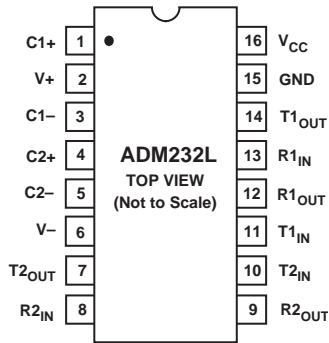
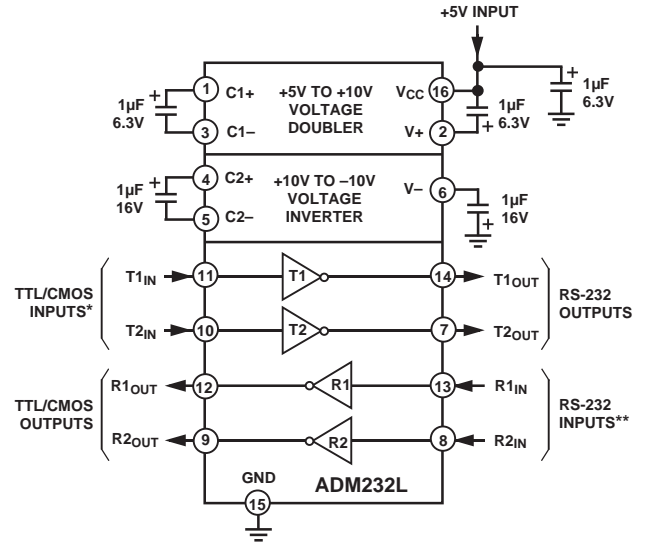

Figure 5. ADM232L DIP/SOIC Pin Configuration



*INTERNAL 400kΩ PULL-UP RESISTOR ON EACH TTL/CMOS INPUT
**INTERNAL 5kΩ PULL-DOWN RESISTOR ON EACH RS-232 INPUT

Figure 6. ADM232L Typical Operating Circuit

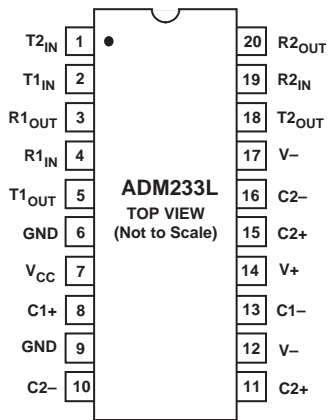
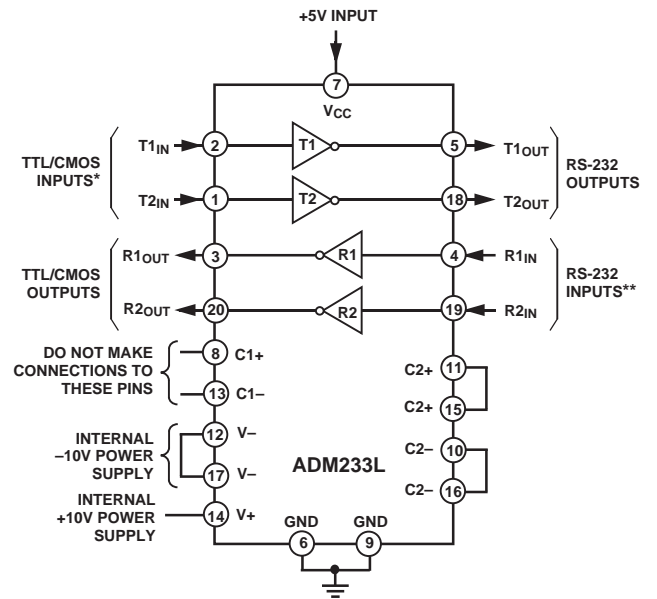

Figure 7. ADM233L DIP Pin Configuration



*INTERNAL 400kΩ PULL-UP RESISTOR ON EACH TTL/CMOS INPUT
**INTERNAL 5kΩ PULL-DOWN RESISTOR ON EACH RS-232 INPUT

Figure 8. ADM233L Typical Operating Circuit

ADM223/ADM230L-ADM241L

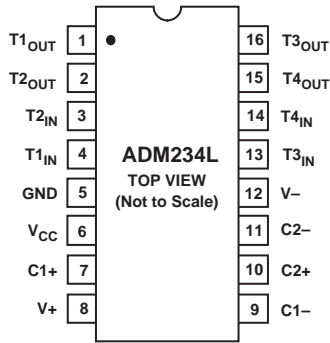
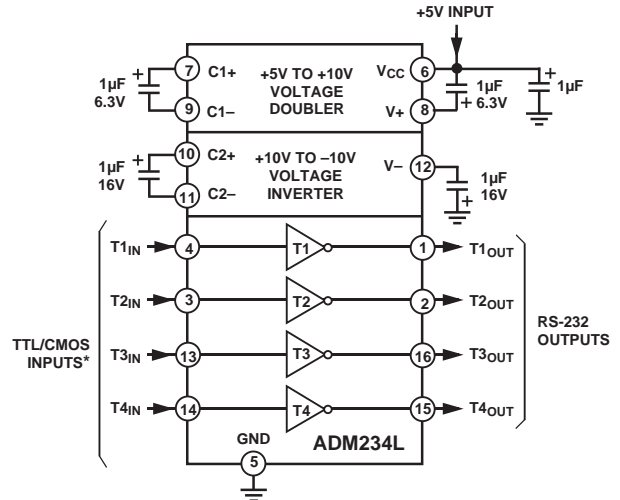

Figure 9. ADM234L DIP/SOIC Pin Configuration



*INTERNAL 400kΩ PULL-UP RESISTOR ON EACH TTL/CMOS INPUT

Figure 10. ADM234L Typical Operating Circuit

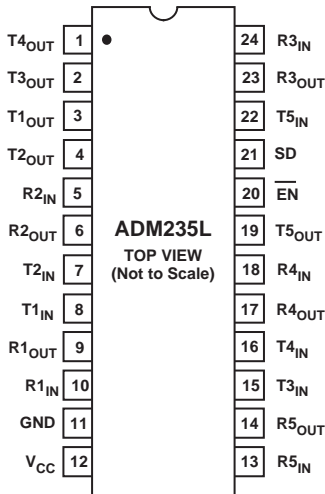
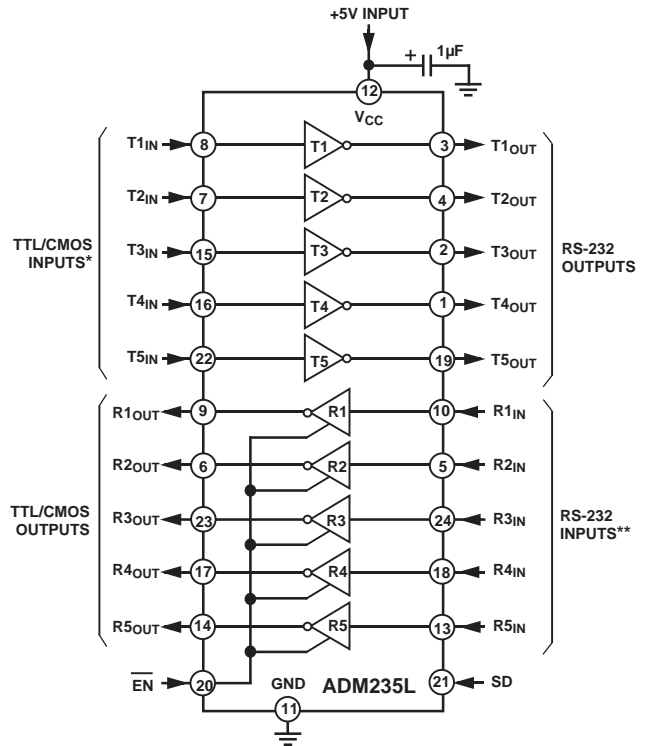

Figure 11. ADM235L DIP Pin Configuration



*INTERNAL 400kΩ PULL-UP RESISTOR ON EACH TTL/CMOS INPUT

**INTERNAL 5kΩ PULL-DOWN RESISTOR ON EACH RS-232 INPUT

Figure 12. ADM235L Typical Operating Circuit

ADM223/ADM230L-ADM241L

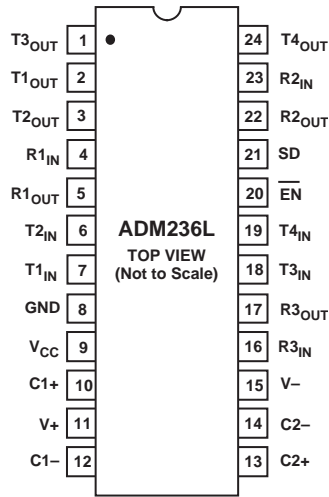

Figure 13. ADM236L DIP/SOIC Pin Configuration

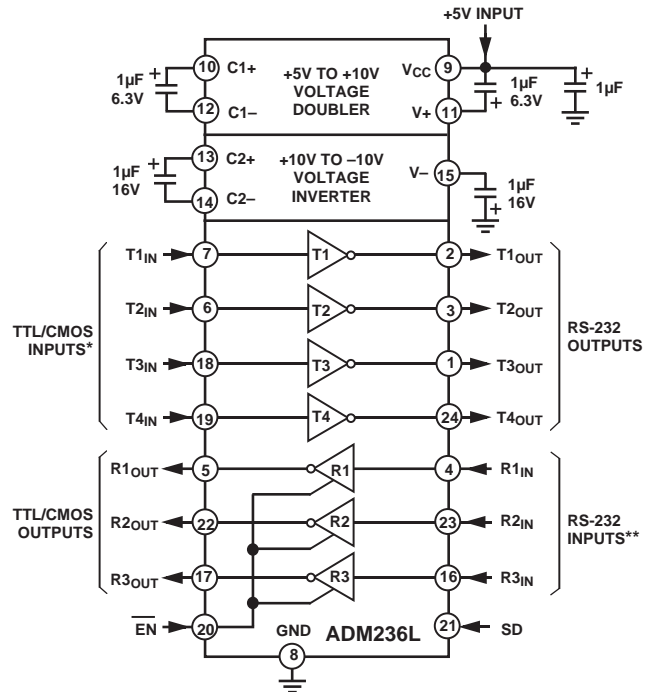

Figure 14. ADM236L Typical Operating Circuit

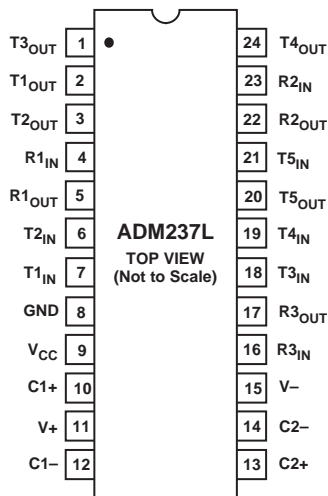

Figure 15. ADM237L DIP/SOIC Pin Configuration

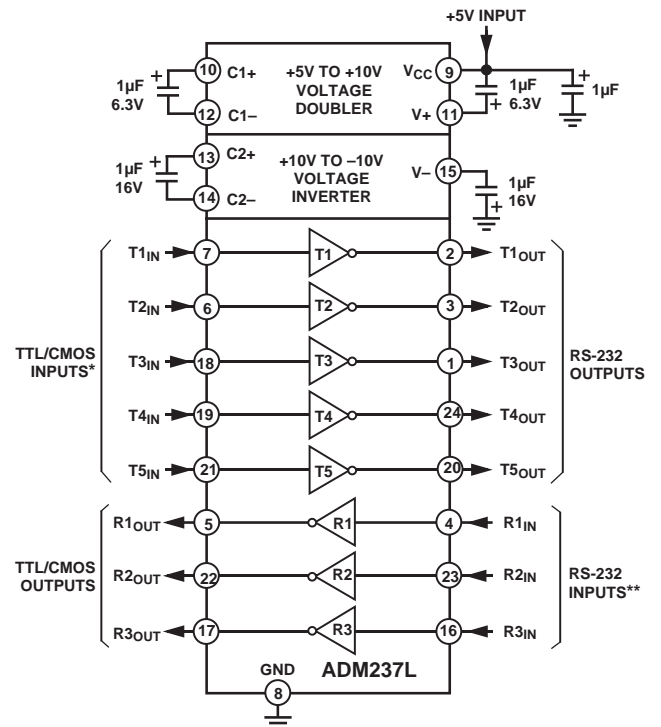

Figure 16. ADM237L Typical Operating Circuit

ADM223/ADM230L-ADM241L

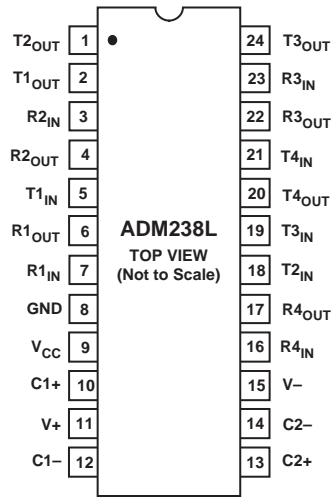
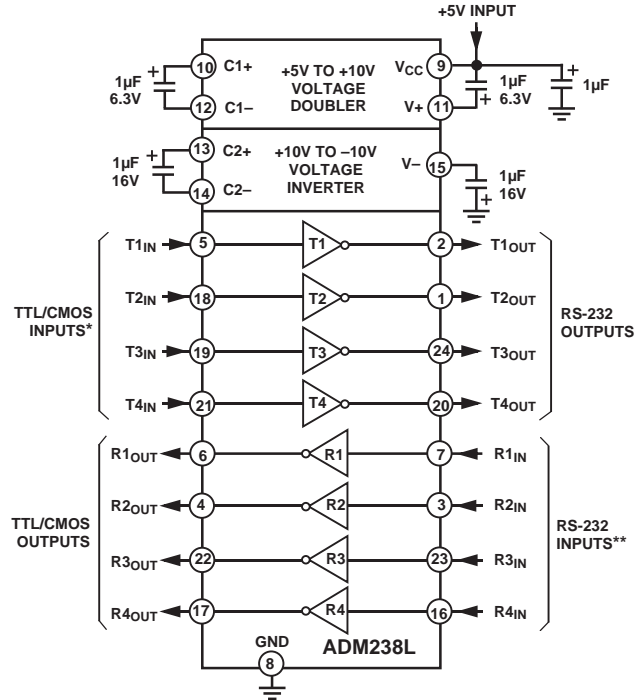

Figure 17. ADM238L DIP/SOIC Pin Configuration



*INTERNAL 400kΩ PULL-UP RESISTOR ON EACH TTL/CMOS INPUT
 **INTERNAL 5kΩ PULL-DOWN RESISTOR ON EACH RS-232 INPUT

Figure 18. ADM238L Typical Operating Circuit

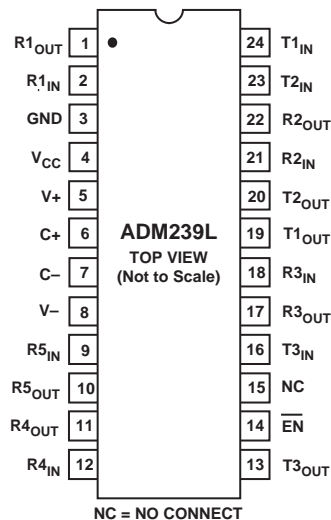
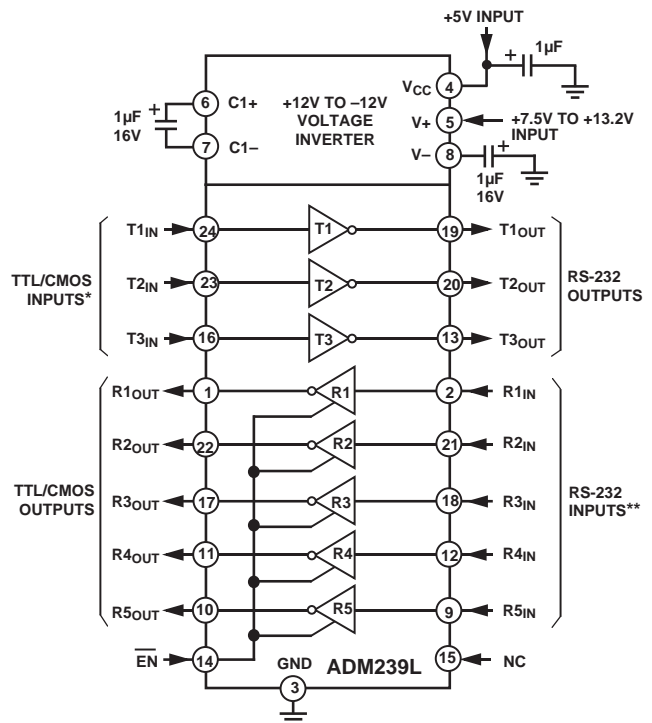

Figure 19. ADM239L DIP/SOIC Pin Configuration



*INTERNAL 400kΩ PULL-UP RESISTOR ON EACH TTL/CMOS INPUT
 **INTERNAL 5kΩ PULL-DOWN RESISTOR ON EACH RS-232 INPUT

Figure 20. ADM239L Typical Operating Circuit

ADM223/ADM230L-ADM241L

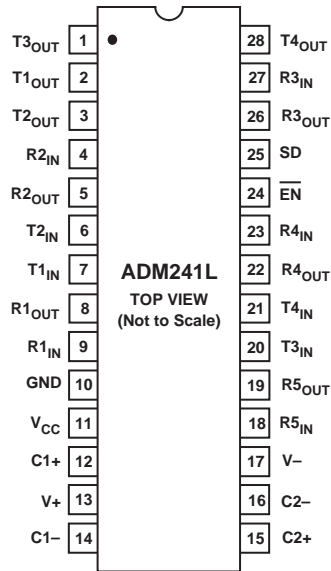

Figure 21. ADM241L SOIC/SSOP Pin Configuration

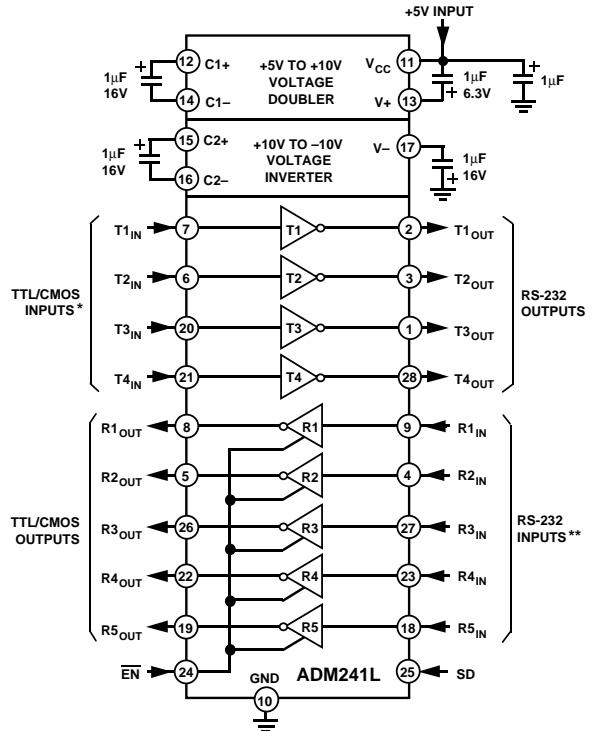

Figure 22. ADM241L Typical Operating Circuit

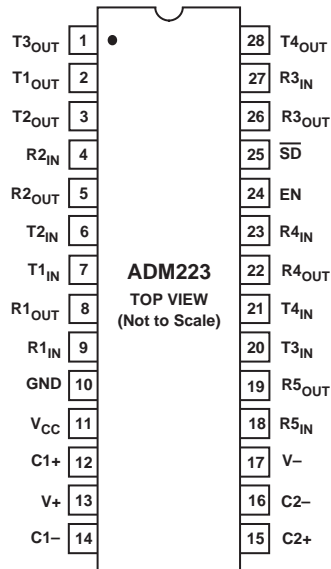

Figure 23. ADM223 SOIC/SSOP Pin Configuration

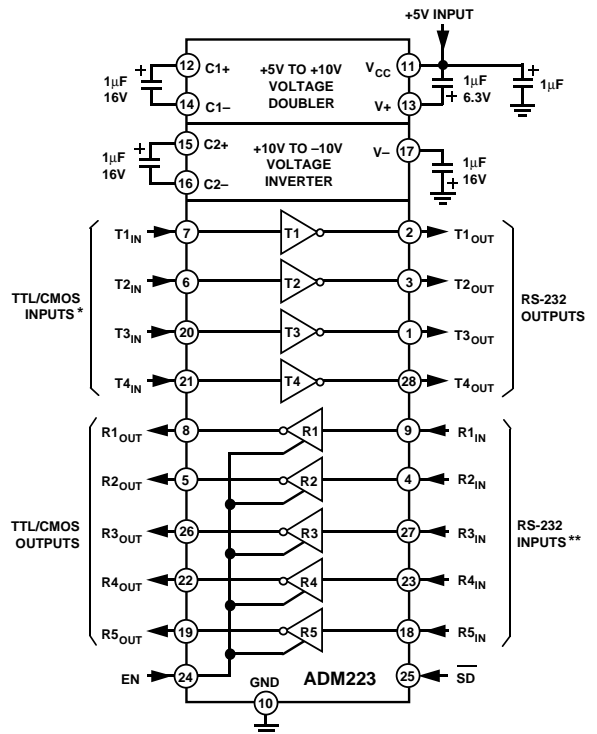

Figure 24. ADM223 Typical Operating Circuit

ADM223/ADM230L–ADM241L

PIN FUNCTION DESCRIPTION

Mnemonic	Function
V _{CC}	Power Supply Input 5 V ± 10% (+5 V ± 5% ADM233L, ADM235L).
V+	Internally generated positive supply (+10 V nominal) on all parts except ADM231L and ADM239L. ADM231L, ADM239L requires external 7.5 V to 13.2 V supply.
V–	Internally generated negative supply (–10 V nominal).
GND	Ground pin. Must be connected to 0 V.
C+	(ADM231L and ADM239L only). External capacitor (+ terminal) is connected to this pin.
C–	(ADM231L and ADM239L only). External capacitor (– terminal) is connected to this pin.
C1+	(ADM230L, ADM232L, ADM234L, ADM236L, ADM237L, ADM238L, ADM241L) External capacitor (+ terminal) is connected to this pin. (ADM233L) The capacitor is connected internally and no external connection to this pin is required.
C1–	(ADM230L, ADM232L, ADM234L, ADM236L, ADM237L, ADM238L, ADM241L) External capacitor (– terminal) is connected to this pin. (ADM233L) The capacitor is connected internally and no external connection to this pin is required.
C2+	(ADM230L, ADM232L, ADM234L, ADM236L, ADM237L, ADM238L, ADM241L) External capacitor (+ terminal) is connected to this pin. (ADM233L) Internal capacitor connections, Pins 11 and 15 must be connected together.
C2–	(ADM230L, ADM232L, ADM234L, ADM236L, ADM237L, ADM238L, ADM241L) External capacitor (– terminal) is connected to this pin. (ADM233L) Internal capacitor connections, Pins 10 and 16 must be connected together.
T _{IN}	Transmitter (Driver) Inputs. These inputs accept TTL/CMOS levels. An internal 400 kΩ pull-up resistor to V _{CC} is connected on each input.
T _{OUT}	Transmitter (Driver) Outputs. These are RS-232 levels (typically ± 10 V).
R _{IN}	Receiver Inputs. These inputs accept RS-232 signal levels. An internal 5 kΩ pull-down resistor to GND is connected on each input.
R _{OUT}	Receiver Outputs. These are TTL/CMOS levels.
$\overline{\text{EN}}/\text{EN}$	Enable Input. Active low on ADM235L, ADM236L, ADM239L, ADM241L. Active high ADM223. This input is used to enable/disable the receiver outputs. With $\overline{\text{EN}}$ = low (EN = high ADM223), the receiver outputs are enabled. With $\overline{\text{EN}}$ = high (EN = low ADM223), the outputs are placed in a high impedance state. This facility is useful for connecting to microprocessor systems.
SD/ $\overline{\text{SD}}$	Shutdown Input. Active high on ADM235L, ADM236L, ADM241L. Active low on ADM223. With SD = high on the ADM235L, ADM236L, ADM241L, the charge pump is disabled, the receiver outputs are placed in a high impedance state and the driver outputs are turned off. With $\overline{\text{SD}}$ low on the ADM223, the charge pump is disabled, the driver outputs are turned off and all receivers except R4 and R5 are placed in a high impedance state. In shutdown, the power consumption reduces to 5 μW.
NC	No Connect. No connections are required to this pin.

Table I. ADM235L, ADM236L, ADM241L Truth Table

SD	$\overline{\text{EN}}$	Status	Transmitters T1–T5	Receivers R1–R5
0	0	Normal Operation	Enabled	Enabled
0	1	Normal Operation	Enabled	Disabled
1	0	Shutdown	Disabled	Disabled

Table II. ADM223 Truth Table

SD	EN	Status	Transmitters T1–T4	Receivers R1–R3	R4, R5
0	0	Shutdown	Disabled	Disabled	Disabled
0	1	Shutdown	Disabled	Disabled	Enabled
1	0	Normal Operation	Enabled	Disabled	Disabled
1	1	Normal Operation	Enabled	Enabled	Enabled

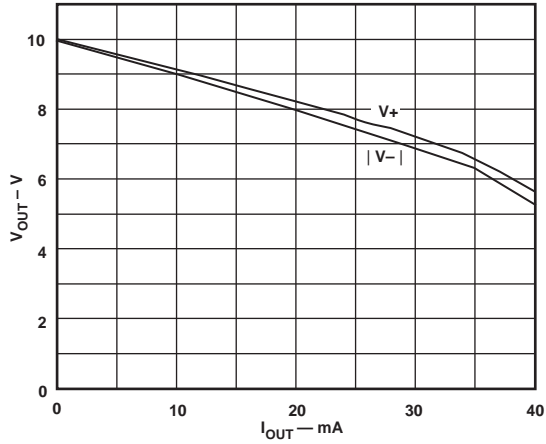

Figure 25. Charge Pump V_+ , V_- vs. Current

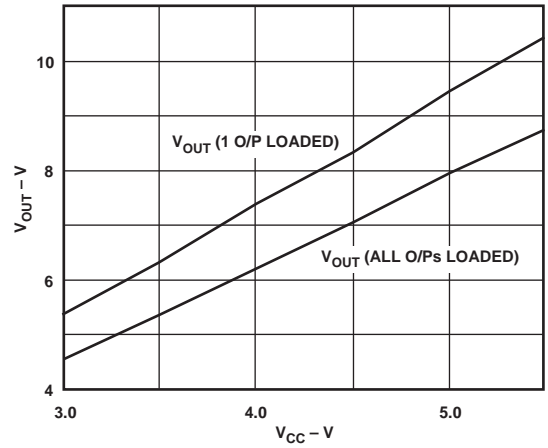

Figure 27. Transmitter Output Voltage vs. V_{CC}

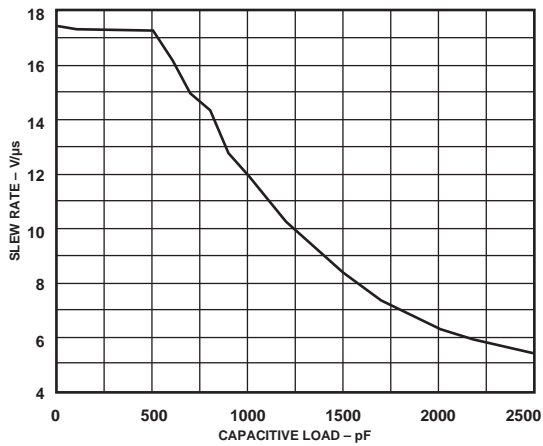

Figure 26. Transmitter Slew Rate vs. Load Capacitance

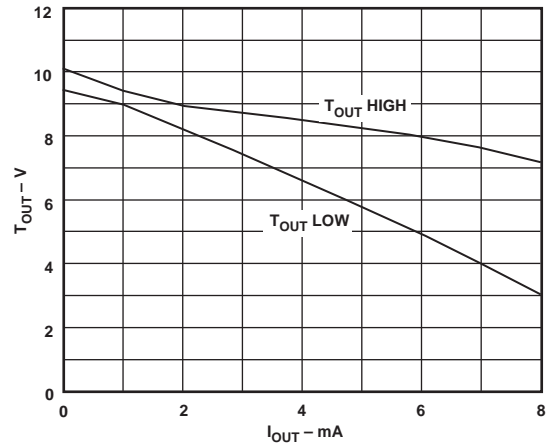

Figure 28. Transmitter Output Voltage vs. Current

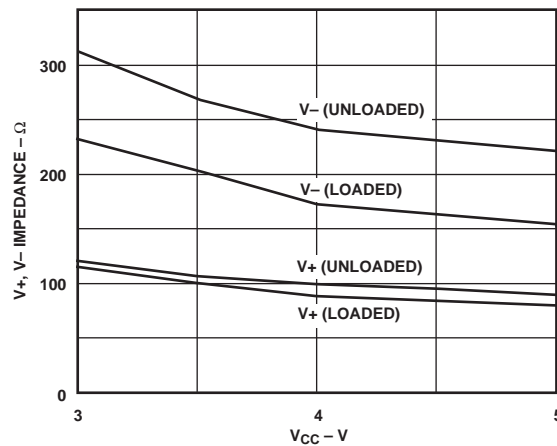

Figure 29. Charge Pump Impedance vs. V_{CC}

ADM223/ADM230L–ADM241L

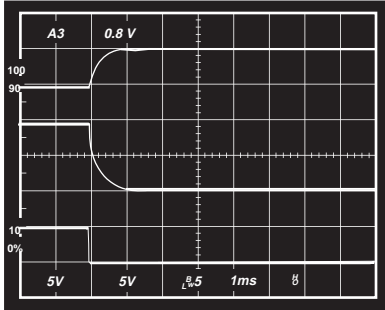

Figure 30. Charge Pump, V+, V– Exiting Shutdown

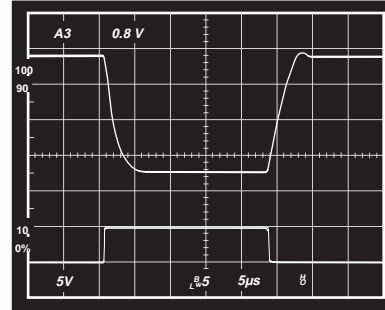

Figure 31. Transmitter Output Loaded Slew Rate

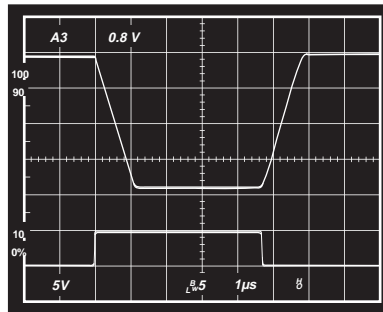

Figure 32. Transmitter Output Unloaded Slew Rate

GENERAL INFORMATION

The ADM223/ADM230L–ADM241L family of RS-232 drivers/receivers are designed to solve interface problems by meeting the EIA-232-E specifications while using a single digital +5 V supply. The EIA-232-E standard requires transmitters which will deliver ± 5 V minimum on the transmission channel and receivers which can accept signal levels down to ± 3 V. The ADM223/ADM230L–ADM241L meet these requirements by integrating step up voltage converters and level shifting transmitters and receivers onto the same chip. CMOS technology is used to keep the power dissipation to an absolute minimum. A comprehensive range of transmitter/receiver combinations is available to cover most communications needs.

The ADM223, ADM230L, ADM235L, ADM236L and ADM241L are particularly useful in battery powered systems as they feature a low power shutdown mode which reduces power dissipation to less than $5 \mu\text{W}$.

The ADM233L and ADM235L are designed for applications where space saving is important as the charge pump capacitors are molded into the package.

The ADM231L and ADM239L include only a negative charge pump converter and are intended for applications where a positive 12 V is available.

To facilitate sharing a common line or for connection to a microprocessor data bus the ADM235L, ADM236L, ADM239L and ADM241L feature an enable (EN, $\overline{\text{EN}}$) function. When disabled, the receiver outputs are placed in a high impedance state.

CIRCUIT DESCRIPTION

The internal circuitry in the ADM230L–ADM241L consists of three main sections. These are:

- (a) A charge pump voltage converter
- (b) RS-232 to TTL/CMOS receivers
- (c) TTL/CMOS to RS-232 transmitters

Charge Pump DC-DC Voltage Converter

The charge pump voltage converter consists of an oscillator and a switching matrix. The converter generates a ± 10 V supply from the input 5 V level. This is done in two stages using a switched capacitor technique as illustrated in Figures 33 and 34. First, the 5 V input supply is doubled to 10 V using capacitor C1 as the charge storage element. The 10 V level is then inverted to generate -10 V using C2 as the storage element.

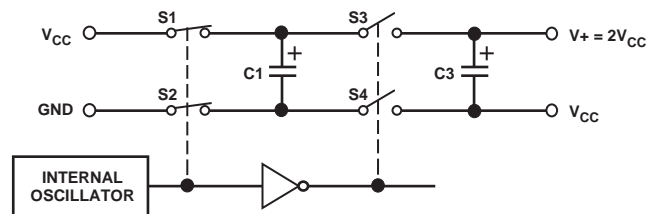

Figure 33. Charge-Pump Voltage Doubler

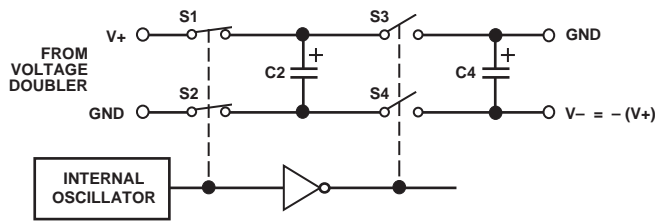

Figure 34. Charge-Pump Voltage Inverter

Capacitors C3 and C4 are used to reduce the output ripple. Their values are not critical and can be reduced if higher levels of ripple are acceptable. The charge pump capacitors C1 and C2 may also be reduced at the expense of higher output impedance on the V+ and V- supplies.

The V+ and V- supplies may also be used to power external circuitry if the current requirements are small.

Transmitter (Driver) Section

The drivers convert TTL/CMOS input levels into EIA-232-E output levels. With $V_{CC} = +5\text{ V}$ and driving a typical EIA-232-E load, the output voltage swing is $\pm 9\text{ V}$. Even under worst case conditions the drivers are guaranteed to meet the $\pm 5\text{ V}$ EIA-232-E minimum requirement.

The input threshold levels are both TTL and CMOS compatible with the switching threshold set at $V_{CC}/4$. With a nominal $V_{CC} = 5\text{ V}$ the switching threshold is 1.25 V typical. Unused inputs may be left unconnected, as an internal 400 k Ω pull-up resistor pulls them high forcing the outputs into a low state.

As required by the EIA-232-E standard, the slew rate is limited to less than 30 V/ μs without the need for an external slew limiting capacitor and the output impedance in the power-off state is greater than 300 Ω .

Receiver Section

The receivers are inverting level shifters which accept EIA-232-E input levels ($\pm 5\text{ V}$ to $\pm 15\text{ V}$) and translate them into 5 V TTL/CMOS levels. The inputs have internal 5 k Ω pull-down resistors to ground and are also protected against overvoltages of up to $\pm 30\text{ V}$. The guaranteed switching thresholds are 0.8 V minimum and 2.4 V maximum which are well within the $\pm 3\text{ V}$ EIA-232-E requirement. The low level threshold is deliberately positive as it ensures that an unconnected input will be interpreted as a low level.

The receivers have Schmitt trigger inputs with a hysteresis level of 0.5 V. This ensures error-free reception for both noisy inputs and for inputs with slow transition times.

Shutdown (SD)

The ADM223, ADM230L, ADM235L, ADM236L and ADM241L feature a control input that may be used to disable the part and reduce the power consumption to less than 5 μW . This is very useful in battery operated systems. During shutdown the charge pump is turned off, the transmitters are disabled and all receivers except R4 and R5 on the ADM223 are put into a high-impedance disabled state. Receivers R4 and R5 on the ADM223 remain enabled during shutdown. This feature allows monitoring external activity such as ring indicator monitoring while the device is in a low power shutdown mode.

The shutdown control input is active high on all parts except the ADM223 where it is active low. Refer to Tables I and II.

Enable Input

The ADM235, ADM239, ADM241L and ADM223 feature an enable input used to enable or disable the receiver outputs. The enable input is active low on the ADM235L, ADM239L, ADM241L and active high on the ADM223. Refer to Tables I and II. When disabled, all receiver outputs are placed in a high impedance state. This function allows the outputs to be connected directly to a microprocessor data bus. It can also be used to allow receivers from different devices to share a common data line. The timing diagram for the enable function is shown in Figure 35.

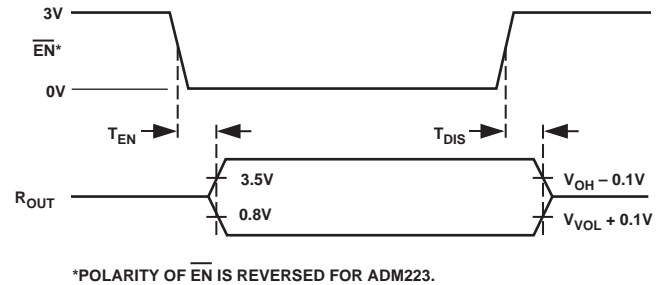

Figure 35. Enable Timing

APPLICATION HINTS

Driving Long Cables

In accordance with the EIA-232-E standard, long cables are permissible provided that the total load capacitance does not exceed 2500 pF. For longer cables which do exceed this, then it is possible to trade off baud rate vs. cable length. Large load capacitances cause a reduction in slew rate, and hence the maximum transmission baud rate is decreased. The ADM230L-ADM241L are designed so that the slew rate reduction with increasing load capacitance is minimized.

For the receivers, it is important that a high level of noise immunity be inbuilt so that slow rise and fall times do not cause multiple output transitions as the signal passes slowly through the transition region. The ADM230L-ADM241L have 0.5 V of hysteresis to guard against this. This ensures that, even in noisy environments, error-free reception can be achieved.

High Baud Rate Operation

The ADM230L-ADM241L feature high slew rates permitting data transmission at rates well in excess of the EIA-232-E specification. The drivers maintain $\pm 5\text{ V}$ signal levels at data rates up to 100-kB/s under worst-case loading conditions.

ADM223/ADM230L-ADM241L

OUTLINE DIMENSIONS

Dimensions shown in inches and (mm).

14-Lead Plastic DIP (N-14)

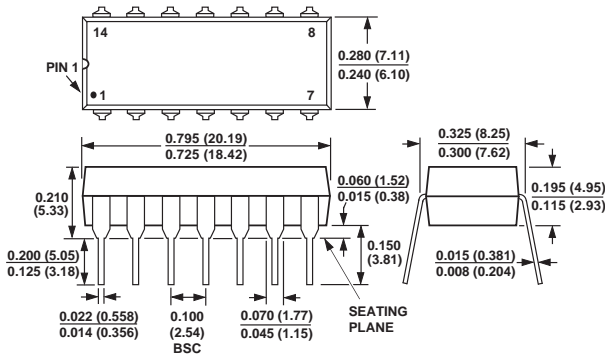

14-Lead Cerdip (Q-14)

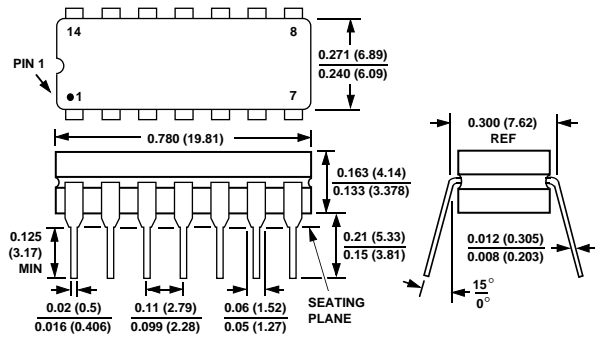

16-Lead Plastic DIP (N-16)

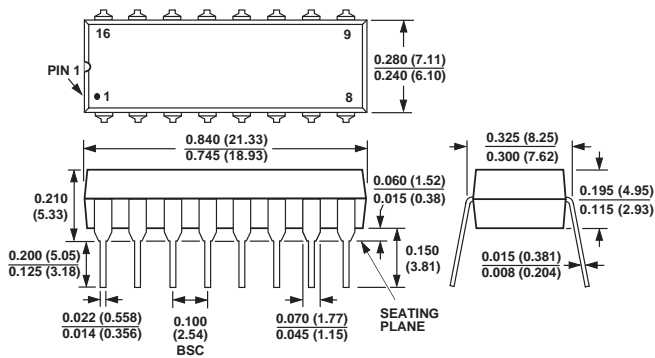

16-Lead Cerdip (Q-16)

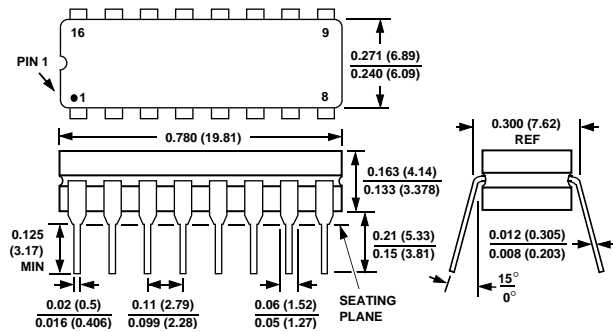

16-Lead SOIC (R-16)

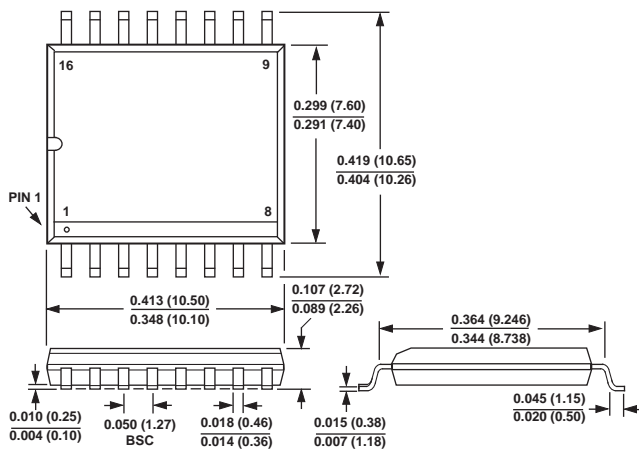

20-Lead Plastic DIP (N-20)

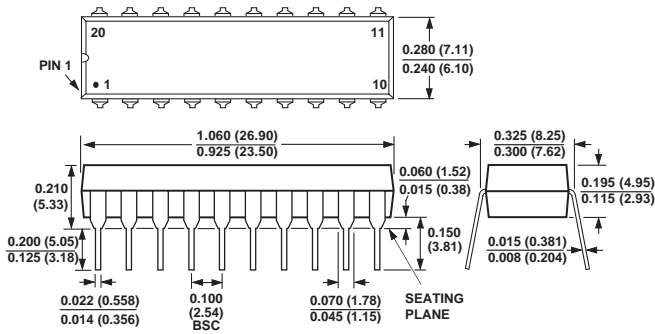

20-Lead Cerdip (Q-20)

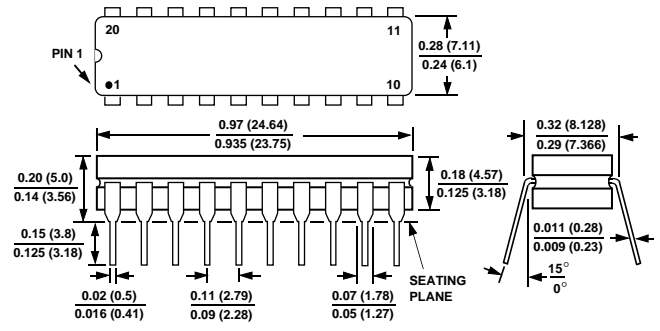

20-Lead SOIC (R-20)

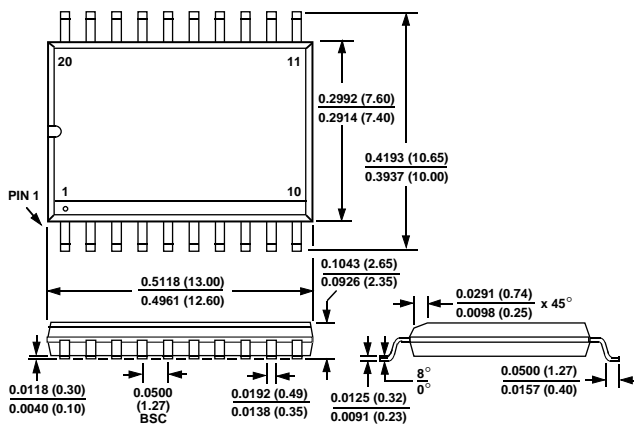

24-Lead Ceramic DIP (D-24)

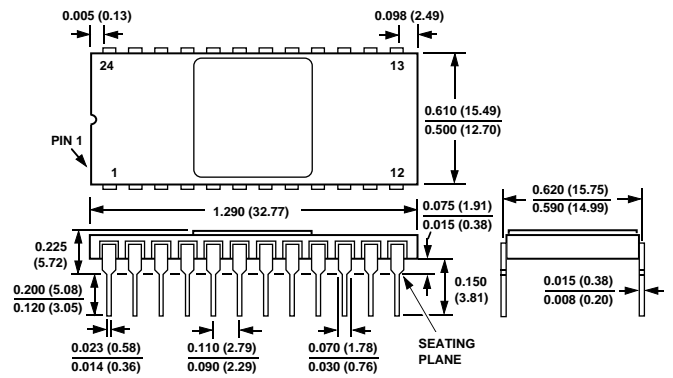

24-Lead Plastic DIP (N-24)

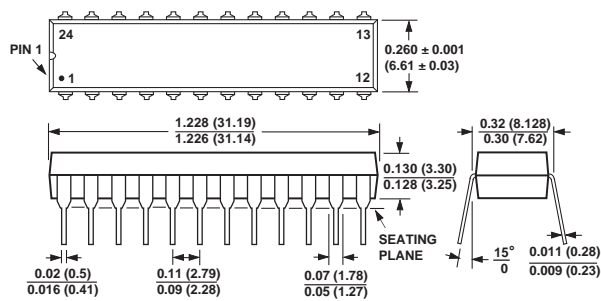

24-Lead Plastic DIP (N-24A)

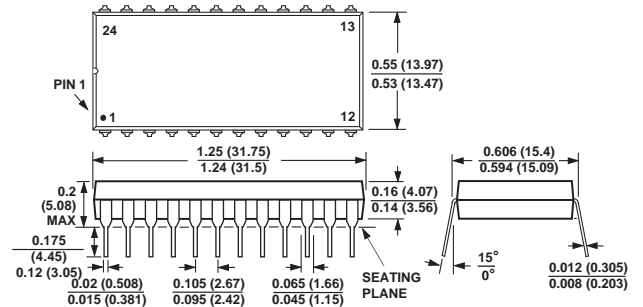

- NOTES
1. LEAD NO. 1 IDENTIFIED BY DOT OR NOTCH
 2. PLASTIC LEADS WILL BE EITHER SOLDER DIPPED OR TIN PLATED IN ACCORDANCE WITH MIL-M-38510 REQUIREMENTS.

24-Lead Cerdip (Q-24)

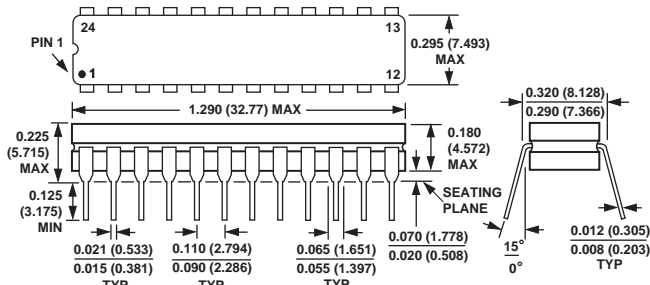

1. LEAD NO. 1 IDENTIFIED BY DOT OR NOTCH.
2. CERDIP LEADS WILL BE EITHER TIN PLATED OR SOLDER DIPPED IN ACCORDANCE WITH MIL-M-38510 REQUIREMENTS.

28-Lead SOIC (R-28)

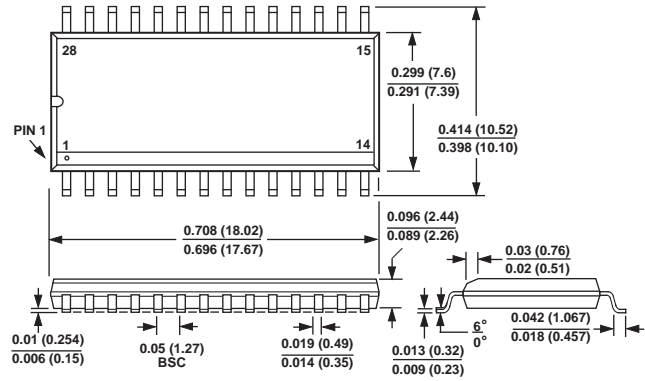

1. LEAD NO. IDENTIFIED BY A DOT.
2. SOICLEADS WILL BE EITHER TIN PLATED OR SOLDER DIPPED IN ACCORDANCE WITH MIL-M-38510 REQUIREMENTS.

24-Lead SOIC (R-24)

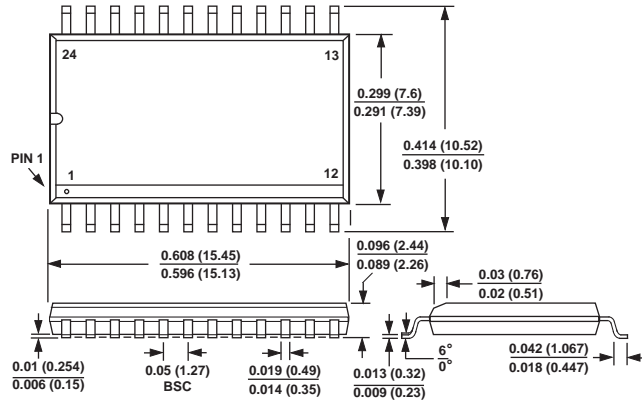

1. LEAD NO. 1 IDENTIFIED BY A DOT.
2. SOIC LEADS WILL BE EITHER TIN PLATED OR SOLDER DIPPED IN ACCORDANCE WITH MIL-M-38510 REQUIREMENTS

28-Lead SSOP (RS-28)

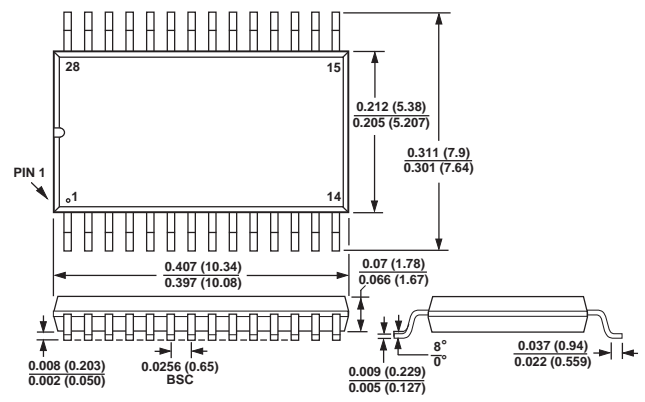

1. LEAD NO. 1 IDENTIFIED BY A DOT.
2. LEADS WILL BE EITHER TIN PLATED OR SOLDER DIPPED IN ACCORDANCE WITH MIL-M-38510 REQUIREMENTS