



ADVANCE INFORMATION

83C196LC, 83C196LD CHMOS 16-BIT MICROCONTROLLER

Automotive

- 22 MHz operation[†]
- 32 Kbytes of on-chip ROM (LC)
16 Kbytes of on-chip ROM (LD)
- 1 Kbyte of on-chip register RAM (LC)
384 bytes of on-chip register RAM (LD)
- 512 bytes of on-chip code RAM (LC only)
- Register-to-register architecture
- Peripheral transaction server (PTS) with high-speed, microcoded interrupt service routines
- Full-duplex serial I/O port with dedicated baud-rate generator
- Enhanced full-duplex, synchronous serial I/O port (SSIO)
- High-speed event processor array
 - Six capture/compare channels
 - Two compare-only channels
 - Two 16-bit software timers
- Programmable 8- or 16-bit external bus
- Design enhancements for EMI reduction
- Oscillator failure detection circuitry
- SFR register that indicates the source of the last reset
- Watchdog timer (WDT)
- Cost reduced replacements for the 87C196JT and 87C196JR.
- -40° C to +125° C ambient temperature
- 52-pin PLCC package

[†] 12 MHz standard; 18 MHz and 22 MHz are speed premium

NOTE

This document contains information on products in the sampling and initial production phases of development. The specifications are subject to change without notice. Verify with your local Intel sales office that you have the latest datasheet before finalizing a design.

The 83C196LC, 83C196LD are low-cost, pin-compatible replacements for the existing 87C196JT and 87C196JR, respectively. These products feature an enhanced synchronous serial I/O (SSIO) port for more flexible communication to other devices. The enhanced SSIO is compatible with Motorola's Serial Peripheral Interface (SPI) protocol and National's Microwire protocol. To optimize die size, the A/D converter was removed for use in those applications that use an off-chip A/D converter.

The MCS[®] 96 microcontroller family members are all high-performance microcontrollers with 16-bit CPUs. The 83C196LC, 83C196LD are composed of a high-speed core with the following peripherals: an asynchronous/synchronous serial I/O port (8096 compatible) with a dedicated 16-bit baud-rate generator; an additional synchronous serial I/O port with full duplex master/slave transceivers; a flexible timer/counter structure with prescaler, cascading, and quadrature capabilities; six modularized, multiplexed high-speed I/O for capture and compare (called event processor array) with 200 ns resolution and double buffered inputs; and a sophisticated, prioritized interrupt structure with programmable peripheral transaction server (PTS). The 83C196LC has the highest memory density of the 52-pin MCS 96 microcontroller family, with 32 Kbytes of on-chip ROM, 1 Kbyte of on-chip register RAM, and 512 bytes of code RAM. The high memory integration of the 83C196LC supports high functionality in a low pin-count package and the use of the C programming language.

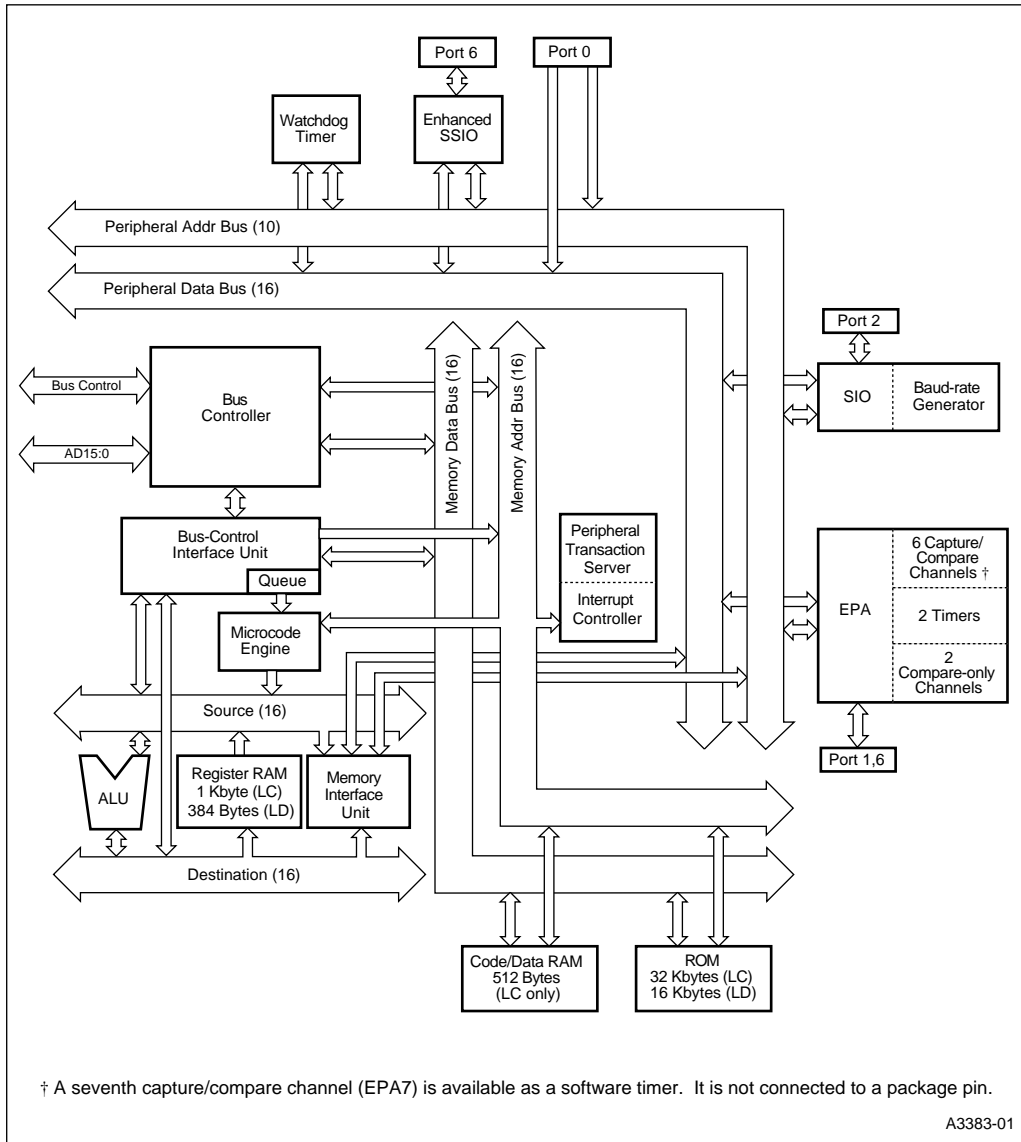

Figure 1. 83C196LC, 83C196LD Block Diagram

1.0 NOMENCLATURE OVERVIEW

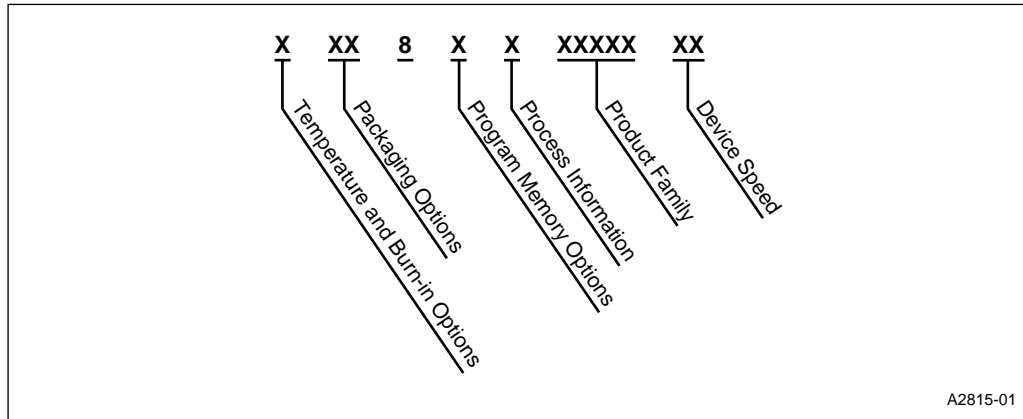

Figure 2. Product Nomenclature

Table 1. Description of Product Nomenclature

Parameter	Options	Description
Temperature and Burn-in Options	A	Automotive operating temperature range (–40° C to 125° C ambient) with Intel standard burn-in.
Packaging Options	N	PLCC
Program-memory Options	3	Internal ROM
Process Information	C	CHMOS
Product Family	196Lx	8XC196Lx family of products
Device Speed	no mark 18 22	12 MHz 18 MHz 22 MHz

2.0 PINOUT

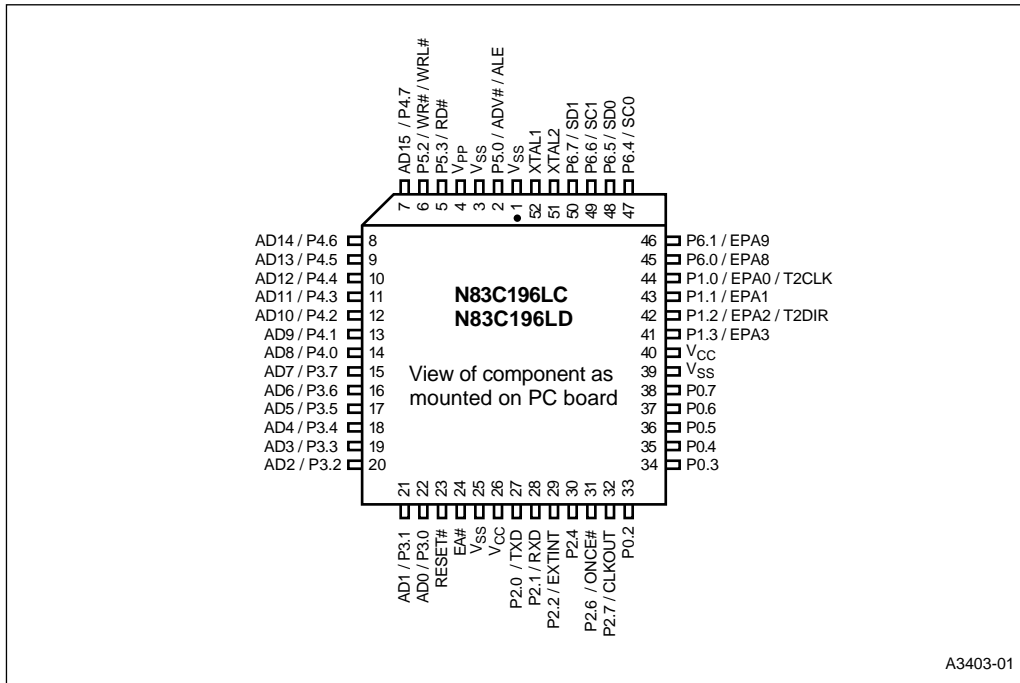

Figure 3. 83C196LC, 83C196LD 52-pin PLCC Package

Table 2. 83C196LC, 83C196LD 52-pin PLCC Package Pin Assignments

Pin	Name	Pin	Name	Pin	Name	Pin	Name
1	V _{SS}	14	AD8/P4.0	27	P2.0/TXD	40	V _{CC}
2	P5.0/ADV#/ALE	15	AD7/P3.7	28	P2.1/RXD	41	P1.3/EPA3
3	V _{SS}	16	AD6/P3.6	29	P2.2/EXTINT	42	P1.2/EPA2/T2DIR
4	V _{PP}	17	AD5/P3.5	30	P2.4	43	P1.1/EPA1
5	P5.3/RD#	18	AD4/P3.4	31	P2.6/ONCE#	44	P1.0/EPA0/T2CLK
6	P5.2/WR#/WRL#	19	AD3/P3.3	32	P2.7/CLKOUT	45	P6.0/EPA8
7	AD15/P4.7	20	AD2/P3.2	33	P0.2	46	P6.1/EPA9
8	AD14/P4.6	21	AD1/P3.1	34	P0.3	47	P6.4/SC0
9	AD13/P4.5	22	AD0/P3.0	35	P0.4	48	P6.5/SD0
10	AD12/P4.4	23	RESET#	36	P0.5	49	P6.6/SC1
11	AD11/P4.3	24	EA#	37	P0.6	50	P6.7/SD1
12	AD10/P4.2	25	V _{SS}	38	P0.7	51	XTAL2
13	AD9/P4.1	26	V _{CC}	39	V _{SS}	52	XTAL1

3.0 SIGNALS

Table 4. Signal Descriptions

Name	Type	Description
AD15:0	I/O	<p>Address/Data Lines</p> <p>These pins provide a multiplexed address and data bus. During the address phase of the bus cycle, address bits 0–15 are presented on the bus and can be latched using ALE or ADV#. During the data phase, 8- or 16-bit data is transferred.</p> <p>AD7:0 share package pins with P3.7:0. AD15:8 share package pins with P4.7:0.</p>
ADV#	O	<p>Address Valid</p> <p>This active-low output signal is asserted only during external memory accesses. ADV# indicates that valid address information is available on the system address/data bus. The signal remains low while a valid bus cycle is in progress and is returned high as soon as the bus cycle completes.</p> <p>An external latch can use this signal to demultiplex the address from the address/data bus. A decoder can also use this signal to generate chip selects for external memory.</p> <p>ADV# shares a package pin with P5.0 and ALE.</p>
ALE	O	<p>Address Latch Enable</p> <p>This active-high output signal is asserted only during external memory cycles. ALE signals the start of an external bus cycle and indicates that valid address information is available on the system address/data bus.</p> <p>An external latch can use this signal to demultiplex the address from the address/data bus.</p>
CLKOUT	O	<p>Output</p> <p>Output of the internal clock generator. The CLKOUT frequency is $\frac{1}{2}$ the oscillator input frequency (F_{XTAL1}). CLKOUT has a 50% duty cycle.</p> <p>CLKOUT shares a package pin with P2.7</p>
EA#	I	<p>External Access</p> <p>This input determines whether memory accesses to special-purpose and program memory partitions are directed to internal or external memory. These accesses are directed to internal memory if EA# is held high and to external memory if EA# is held low. For an access to any other memory location, the value of EA# is irrelevant.</p> <p>EA# is sampled and latched only on the rising edge of RESET#. Changing the level of EA# after reset has no effect.</p>
EPA9:8 EPA3:0	I/O	<p>Event Processor Array (EPA) Capture/Compare Channels</p> <p>High-speed input/output signals for the EPA capture/compare channels.</p> <p>The EPA signals share package pins with the following signals: EPA0/P1.0/T2CLK, EPA1/P1.1, EPA2/P1.2/T2DIR, EPA3/P1.3, EPA8/P6.0/COMP0, and EPA9/P6.1/COMP1. EPA7 does not connect to a package pin. It cannot be used to capture an event, but it can function as a software timer. EPA6:4 are not implemented.</p>

Table 4. Signal Descriptions (Continued)

Name	Type	Description
EXTINT	I	<p>External Interrupt</p> <p>In normal operating mode, a rising edge on EXTINT sets the EXTINT interrupt pending bit. EXTINT is sampled during phase 2 (CLKOUT high). The minimum high time is one state time.</p> <p>In powerdown mode, asserting the EXTINT signal for at least 50 ns causes the device to resume normal operation. The interrupt does not need to be enabled.</p> <p>In idle mode, asserting any enabled interrupt causes the device to resume normal operation.</p> <p>EXTINT shares a package pin with P2.2.</p>
ONCE#	I	<p>On-circuit Emulation</p> <p>Holding ONCE# low during the rising edge of RESET# places the microcontroller into on-circuit emulation (ONCE) mode. This mode puts all pins into a high-impedance state, thereby isolating the microcontroller from other components in the system. The value of ONCE# is latched when the RESET# pin goes inactive. While the microcontroller is in ONCE mode, you can debug the system using a clip-on emulator.</p> <p>To exit ONCE mode, reset the microcontroller by pulling the RESET# signal low. To prevent inadvertent entry into ONCE mode, either configure this pin as an output or hold it high during reset and ensure that your system meets the V_{IH} specification.</p> <p>ONCE# shares a package pin with P2.6.</p>
P0.7:2	I	<p>Port 0</p> <p>This is a high-impedance, input-only port. Port 0 pins should not be left floating.</p>
P1.3:0	I/O	<p>Port 1</p> <p>This is a standard bidirectional port that shares package pins with individually selectable special-function signals.</p> <p>Port 1 shares package pins with the following signals: P1.0/EPA0/T2CLK, P1.1/EPA1, P1.2/EPA2/T2DIR, P1.3/EPA3.</p>
P2.7:6 P2.4 P2.2:0	I/O	<p>Port 2</p> <p>This is a standard bidirectional port that shares package pins with individually selectable special-function signals.</p> <p>P2.6 is multiplexed with the ONCE function. If this pin is held low during reset, the device will enter ONCE mode, so exercise caution if you use this pin for input. If you choose to configure this pin as an input, always hold it low/high during reset and ensure that your system meets the V_{IH} specification to prevent inadvertent entry into ONCE mode.</p> <p>Port 2 shares package pins with the following signals: P2.0/TXD, P2.1/RXD, P2.2/EXTINT, P2.6/ONCE#, P2.7/CLKOUT.</p>
P3.7:0	I/O	<p>Port 3</p> <p>This is a memory-mapped, 8-bit, bidirectional port with programmable open-drain or complementary output modes. The pins are shared with the multiplexed address/data bus, which has complementary drivers.</p> <p>P3.7:0 share package pins with AD7:0.</p>

Table 4. Signal Descriptions (Continued)

Name	Type	Description
P4.7:0	I/O	Port 4 This is a memory-mapped, 8-bit, bidirectional port with open-drain or complementary output modes. The pins are shared with the multiplexed address/data bus, which has complementary drivers. P4.7:0 share package pins with AD15:8.
P5.3:2 P5.0	I/O	Port 5 This is a memory-mapped, bidirectional port. Port 5 shares package pins with the following signals: P5.0/ADV#/ALE, P5.2/WR#/WRL#/PLEN, and P5.3/RD#. P5.1 and P5.7:4 are not implemented.
P6.7:4 P6.1:0	O	Port 6 This is a standardbidirectional port. Port 6 shares package pins with the following signals: P6.0/EPA8/COMP0, P6.1/EPA9/COMP1, P6.4/SC0, P6.5/SD0, P6.6/SC1, and P6.7/SD1.
RD#	O	Read Read-signal output to external memory. RD# is asserted during external memory reads. RD# shares a package pin with P5.3.
RESET#	I/O	Reset A level-sensitive reset input to, and an open-drain system reset output from, the microcontroller. Either a falling edge on RESET# or an internal reset turns on a pull-down transistor connected to the RESET# pin for 16 state times. In the powerdown and idle modes, asserting RESET# causes the microcontroller to reset and return to normal operating mode. After a reset, the first instruction fetch is from 2080H.
RXD	I/O	Receive Serial Data In modes 1, 2, and 3, RXD receives serial port input data. In mode 0, it functions as either an input or an open-drain output for data. RXD shares a package pin with P2.1.
SC1:0	I/O	Clock Pins for SSIO0 and 1 SC0 shares a package pin with P6.4, and SC1 shares a package pin with P6.6.
SD1:0	I/O	Data Pins for SSIO0 and 1 These pins are the data I/O pins for SSIO0 and 1. For transmissions, configure SDx as a complementary output signal. For receptions, configure SDx as a high-impedance input signal. SD0 shares a package pin with P6.5, and SD1 shares a package pin with P6.7.
T2CLK	I	Timer 2 External Clock External clock for timer 2. Timer 2 increments (or decrements) on both rising and falling edges of T2CLK. It is also used in conjunction with T2DIR for quadrature counting mode. T2CLK shares a package pin with P1.0 and EPA0.

Table 4. Signal Descriptions (Continued)

Name	Type	Description
T2DIR	I	<p>Timer 2 External Direction</p> <p>External direction (up/down) for timer 2. Timer 2 increments when T2DIR is high and decrements when it is low. It is also used in conjunction with T2CLK for quadrature counting mode.</p> <p>T2DIR shares a package pin with P1.2 and EPA2.</p>
TXD	O	<p>Transmit Serial Data</p> <p>In serial I/O modes 1, 2, and 3, TXD transmits serial port output data. In mode 0, it is the serial clock output.</p> <p>TXD shares a package pin with P2.0.</p>
V _{CC}	PWR	<p>Digital Supply Voltage</p> <p>Connect each V_{CC} pin to the digital supply voltage.</p>
V _{PP}	PWR	<p>Powerdown Exit</p> <p>V_{PP} causes the device to exit powerdown mode when it is driven low for at least 50 ns. Use this method to exit powerdown only when using an external clock source because it enables the internal phase clocks, but not the internal oscillator.</p> <p>If you do not plan to use the powerdown feature, connect V_{PP} to V_{CC}.</p>
V _{SS}	GND	<p>Digital Circuit Ground</p> <p>These pins supply ground for the digital circuitry. Connect each V_{SS} pin to ground through the lowest possible impedance path.</p>
WR#	O	<p>Write[†]</p> <p>This active-low output indicates that an external write is occurring. This signal is asserted only during external memory writes.</p> <p>WR# shares a package pin with P5.2 and WRL#.</p> <p>[†] When this pin is configured as a special-function signal (P5_MODE.2 = 1), the chip configuration register 0 (CCR0) determines whether it functions as WR# or WRL#. CCR0.2 = 1 selects WR#; CCR0.2 = 0 selects WRL#.</p>
WRL#	O	<p>Write Low[†]</p> <p>During 16-bit bus cycles, this active-low output signal is asserted for low-byte writes and word writes to external memory. During 8-bit bus cycles, WRL# is asserted for all write operations.</p> <p>WRL# shares a package pin with P5.2 and WR#.</p> <p>[†] When this pin is configured as a special-function signal (P5_MODE.2 = 1), the chip configuration register 0 (CCR0) determines whether it functions as WR# or WRL#. CCR0.2 = 1 selects WR#; CCR0.2 = 0 selects WRL#.</p>

Table 4. Signal Descriptions (Continued)

Name	Type	Description
XTAL1	I	Input Crystal/Resonator or External Clock Input Input to the on-chip oscillator and the internal clock generators. The internal clock generators provide the peripheral clocks, CPU clock, and CLKOUT signal. When using an external clock source instead of the on-chip oscillator, connect the clock input to XTAL1. The external clock signal must meet the V_{IH} specification for XTAL1.
XTAL2	O	Inverted Output for the Crystal/Resonator Output of the on-chip oscillator inverter. Leave XTAL2 floating when the design uses an external clock source instead of the on-chip oscillator.

4.0 ADDRESS MAP

Table 5. Address Map

Hex Address Range		Description	Addressing Modes
LC	LD		
FFFF A000	FFFF 6000	External device (memory or I/O) connected to address/data bus	Indirect or indexed
9FFF 2080	5FFF 2080	Program memory (internal nonvolatile or external memory); see Note 1	Indirect or indexed
207F 2000	207F 2000	Special-purpose memory (internal nonvolatile or external memory)	Indirect or indexed
1FFF 1FE0	1FFF 1FE0	Memory-mapped SFRs	Indirect or indexed
1FDF 1F00	1FDF 1F00	Peripheral SFRs	Indirect, indexed, or windowed direct
1EFF 1C00	1EFF 1C00	External device (memory or I/O) connected to address/data bus; (future SFR expansion; see Note 2)	Indirect or indexed
1BFF 0600	1BFF 0600	External device (memory or I/O) connected to address/data bus	Indirect or indexed
05FF 0400	—	Internal code or data RAM	Indirect or indexed
—	05FF 0180	External device (memory or I/O) connected to address/data bus	Indirect or indexed
03FF 0100	017F 0100	Upper register file (general-purpose register RAM)	Indirect, indexed, or windowed direct
00FF 0000	00FF 0000	Lower register file (register RAM, stack pointer, and CPU SFRs)	Direct, indirect, or indexed

NOTES:

1. After a reset, the microcontroller fetches its first instruction from 2080H.
2. The content or function of these locations may change in future microcontroller revisions, in which case a program that relies on a location in this range might not function properly.

5.0 ELECTRICAL CHARACTERISTICS

ABSOLUTE MAXIMUM RATINGS

Storage temperature -60° C to +150° C
 Supply voltage with respect to V_{SS} -0.5 V to +13.0 V
 Power dissipation 0.5 W

OPERATING CONDITIONS[†]

T_A (Ambient temperature under bias) -40° C to +125° C
 V_{CC} (Digital supply voltage) 4.50 V to 5.50 V
 F_{X_{TAL}1} (Oscillator frequency) 4 MHz to 22 MHz

NOTICE: This document contains information on products in the sampling and initial production phases of development. The specifications are subject to change without notice. Verify with your local Intel sales office that you have the latest datasheet before finalizing a design.

[†] **WARNING:** Stressing the device beyond the “Absolute Maximum Ratings” may cause permanent damage. These are stress ratings only. Operation beyond the “Operating Conditions” is not recommended and extended exposure beyond the “Operating Conditions” may affect device reliability.

ADVANCE INFORMATION

5.1 DC Characteristics

Table 6. DC Characteristics at $V_{CC} = 4.5V - 5.5V$

Symbol	Parameter	Min	Typical	Max	Units	Test Conditions
I_{CC}	V_{CC} supply current ($-40^{\circ}C$ to $+125^{\circ}C$ ambient)			88	mA	$F_{XTAL1} = 20\text{ MHz}$, $V_{CC} = V_{PP} = 5.5V$ (While device is in reset)
I_{CC1}	Active mode supply current (typical)		55		mA	
I_{IDLE}	Idle mode current		20	40	mA	$F_{XTAL1} = 20\text{ MHz}$, $V_{CC} = V_{PP} = 5.5V$
I_{PD}	Powerdown mode current		50	TBD	μA	$V_{CC} = V_{PP} = 5.5V$ (Note 6)
V_{IL}	Input low voltage (all pins)	$-0.5V$		$0.3 V_{CC}$	V	
V_{IH}	Input high voltage (all pins)	$0.7 V_{CC}$		$V_{CC} + 0.5$	V	
V_{OL}	Output low voltage (outputs configured as complementary)			0.3 0.45 1.5	V V V	$I_{OL} = 200\ \mu A$ (Notes 3, 5) $I_{OL} = 3.2\text{ mA}$ $I_{OL} = 7.0\text{ mA}$
V_{OH}	Output high voltage (outputs configured as complementary)	$V_{CC} - 0.3$ $V_{CC} - 0.7$ $V_{CC} - 1.5$			V V V	$I_{OH} = -200\ \mu A$ (Notes 3, 5) $I_{OH} = -3.2\text{ mA}$ $I_{OH} = -7.0\text{ mA}$
I_{LI}	Input leakage current (standard inputs, ports 3 & 4)			± 10	μA	$V_{SS} \leq V_{IN} \leq V_{CC}$ (Note 2)
I_{LI1}	Input leakage current (port 0)			± 2.0	μA	$V_{SS} \leq V_{IN} \leq V_{REF}$
I_{IH}	Input high current (NMI pin)			+175	μA	$V_{SS} \leq V_{IN} \leq V_{CC}$
V_{OH2}	Output high voltage in reset	$V_{CC} - 1V$			V	$I_{OH} = -15\ \mu A$ (Note 1)
I_{OH2}	Output high current in reset	-25 -45 -50		-120 -240 -280	μA μA μA	$V_{OH2} = V_{CC} - 1.0V$ $V_{OH2} = V_{CC} - 2.5V$ $V_{OH2} = V_{CC} - 4.0V$
R_{RST}	Reset pullup resistor	6K		65K	Ω	

NOTES:

- All bidirectional pins except CLKOUT. CLKOUT is not pulled weakly high in reset. Bidirectional pins include ports 1–6.
- Standard input pins include XTAL1, EA#, RESET#, P0.7:2, and ports 1–6 when configured as inputs.
- All bidirectional pins when configured as complementary outputs.
- Device is static and should operate below 1 Hz, but is only tested down to 4 MHz.
- Maximum I_{OL} or I_{OH} currents per pin will be characterized and published at a later date. Target values are $\pm 10\text{ mA}$.
- Typicals are based on a limited number of samples and are not guaranteed. The values listed are at room temperature and $V_{CC} = 5.0V$.

Table 6. DC Characteristics at $V_{CC} = 4.5V - 5.5V$ (Continued)

Symbol	Parameter	Min	Typical	Max	Units	Test Conditions
C_S	Pin capacitance (any pin to V_{SS})			10	pF	$F_{TEST} = 1.0$ MHz
R_{WPU}	Weak pullup resistance (approximate)		150K		Ω	(Note 6)

NOTES:

1. All bidirectional pins except CLKOUT. CLKOUT is not pulled weakly high in reset. Bidirectional pins include ports 1–6.
2. Standard input pins include XTAL1, EA#, RESET#, P0.7:2, and ports 1–6 when configured as inputs.
3. All bidirectional pins when configured as complementary outputs.
4. Device is static and should operate below 1 Hz, but is only tested down to 4 MHz.
5. Maximum I_{OL} or I_{OH} currents per pin will be characterized and published at a later date. Target values are ± 10 mA.
6. Typicals are based on a limited number of samples and are not guaranteed. The values listed are at room temperature and $V_{CC} = 5.0V$.

5.2 AC Characteristics

Test Conditions: capacitive load on all pins = 100 pF, rise and fall times = 10 ns, $F_{XTAL1} = 22$ MHz.

Table 7. AC Characteristics

Symbol	Parameter	Min	Max	Units
The 83C196LC, 83C196LD meets these specifications				
F_{XTAL1}	Oscillator Frequency	4.0	22.0	MHz ⁽¹⁾
T_{XTAL1}	Oscillator Period ($1/F_{XTAL1}$)	45.45	200	ns
T_{XHCH}	XTAL1 High to CLKOUT High or Low	20	110	ns ⁽²⁾
T_{CLCL}	CLKOUT Cycle Time	$2 T_{XTAL1}$		ns
T_{CHCL}	CLKOUT High Period	$T_{XTAL1} - 10$	$T_{XTAL1} + 15$	ns
T_{CLLH}	CLKOUT Falling to ALE Rising	-10	15	ns
T_{LLCH}	ALE Falling to CLKOUT Rising	-20	15	ns
T_{LHLH}	ALE Cycle Time	$4 T_{XTAL1}$		ns
T_{LHLL}	ALE High Period	$T_{XTAL1} - 10$	$T_{XTAL1} + 10$	ns
T_{AVLL}	Address Setup to ALE Low	$T_{XTAL1} - 15$		ns
T_{LLAX}	Address Hold after ALE Low	$T_{XTAL1} - 40$		ns
T_{LLRL}	ALE Low to RD# Low	$T_{XTAL1} - 30$		ns
T_{RLCL}	RD# Low to CLKOUT Low	-10	20	ns
T_{RLRH}	RD# Low to RD# High	$T_{XTAL1} - 5$		ns
T_{RHLH}	RD# High to ALE Rising	T_{XTAL1}	$T_{XTAL1} + 25$	ns ⁽³⁾
T_{RLAZ}	RD# Low to Address Float		5	ns ⁽⁵⁾
T_{LLWL}	ALE Low to WR# Low	$T_{XTAL1} - 10$		ns
T_{CLWL}	CLKOUT Low to WR# Falling Edge	-10	20	ns
T_{QVWH}	Data Valid to WR# High	$T_{XTAL1} - 23$		ns
T_{CHWH}	CLKOUT High to WR# Rising Edge	-10	15	ns
T_{WLWH}	WR# Low to WR# High	$T_{XTAL1} - 20$		ns
T_{WHQX}	Data Hold after WR# High	$T_{XTAL1} - 25$		ns
T_{WHLH}	WR# High to ALE High	$T_{XTAL1} - 10$	$T_{XTAL1} + 15$	ns ⁽³⁾
T_{WHAX}	AD15:8 Hold after WR# High	$T_{XTAL1} - 30$ ⁽⁴⁾		ns
T_{RHAX}	AD15:8 Hold after RD# High	$T_{XTAL1} - 30$ ⁽⁴⁾		ns

NOTES:

1. Testing is performed at 4 MHz, however, the device is static by design and will typically operate below 1 Hz.
2. Typical specifications, not guaranteed.
3. Assuming back-to-back bus cycles.
4. 8-bit bus only.
5. T_{RLAZ} (max) = 5 ns by design.

Table 7. AC Characteristics (Continued)

Symbol	Parameter	Min	Max	Units
The external memory system must meet these specifications				
T_{AVDV}	Address Valid to Input Data Valid		$3 T_{XTAL1} - 55$	ns
T_{RLDV}	RD# Low to Input Data Valid		$T_{XTAL1} - 22$	ns
T_{CLDV}	CLKOUT Low to Input Data Valid		$T_{XTAL1} - 50$	ns
T_{RHDZ}	RD# High to Input Data Float		T_{XTAL1}	ns
T_{RXDX}	Data Hold after RD# Inactive	0		ns

NOTES:

1. Testing is performed at 4 MHz, however, the device is static by design and will typically operate below 1 Hz.
2. Typical specifications, not guaranteed.
3. Assuming back-to-back bus cycles.
4. 8-bit bus only.
5. T_{RLAZ} (max) = 5 ns by design.

Table 8. AC Timing Symbol Definitions

Character	Signal(s)
A	AD15:0
C	CLKOUT
D	AD15:0, AD7:0
L	ALE
Q	AD15:0, AD7:0
R	RD#
W	WR#, WRL#

Character	Condition
H	High
L	Low
V	Valid
X	No Longer Valid
Z	Floating (low impedance)

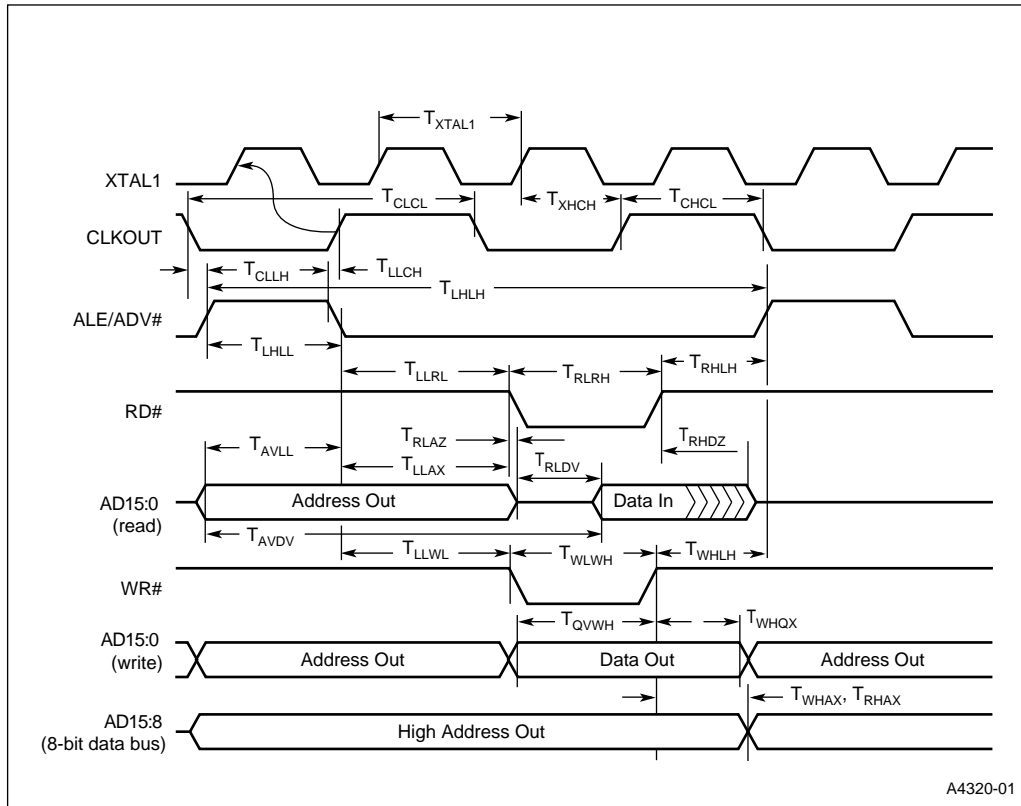

Figure 4. System Bus Timing

A4320-01

5.3 AC Characteristics — Serial Port, Shift Register Mode

Test Conditions: $T_A = -40^{\circ}\text{C}$ to $+125^{\circ}\text{C}$; $V_{CC} = 5.0\text{V} \pm 10\%$; $V_{SS} = 0.0\text{V}$; Load Capacitance = 100 pF

Table 9. Serial Port Timing — Shift Register Mode

Symbol	Parameter	Min	Max	Units
T_{XLXL}	Serial port clock period	$8 T_{XTAL1}$		ns
T_{XLXH}	Serial port clock falling edge to rising edge	$4 T_{XTAL1} - 50$	$4 T_{XTAL1} + 50$	ns
T_{QVXH}	Output data setup to clock high	$3 T_{XTAL1}$		ns
T_{XHGX}	Output data hold after clock high	$2 T_{XTAL1} - 50$		ns
T_{XHQV}	Next output data valid after clock high		$2 T_{XTAL1} + 50$	ns
T_{DVXH}	Input data setup to clock high	$2 T_{XTAL1} + 200$		ns
T_{XHDX}^{\dagger}	Input data hold after clock high	0		ns
T_{XHQZ}^{\dagger}	Last clock high to output float		$5 T_{XTAL1}$	ns

[†] Parameter not tested.

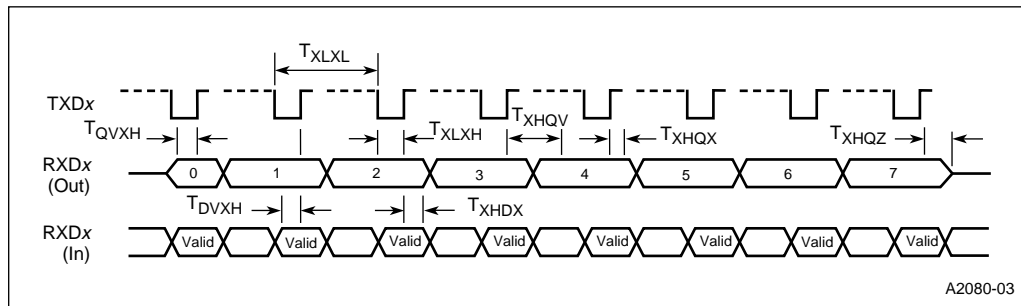

Figure 5. Serial Port Waveform — Shift Register Mode

5.4 AC Characteristics — Synchronous Serial Port

Table 10. Synchronous Serial Port Timing

Symbol	Parameter	Min	Max	Units
T_{CLCL}	Synchronous Serial Port Clock period	TBD	TBD	ns
T_{CLCH}	Synchronous Serial Port Clock falling edge to rising edge	TBD	TBD	ns
T_{D1VD}	Setup time for MSB output	TBD		ns
T_{CXDV}	Setup time for D6:0 output	$1.5t + 20$		ns
T_{CXDX}	Output data hold after clock high	$0.5t$		ns
T_{DVCX}	Setup time for input data	10		ns
T_{DXCX}	Input data hold after clock high	$t + 5$		ns

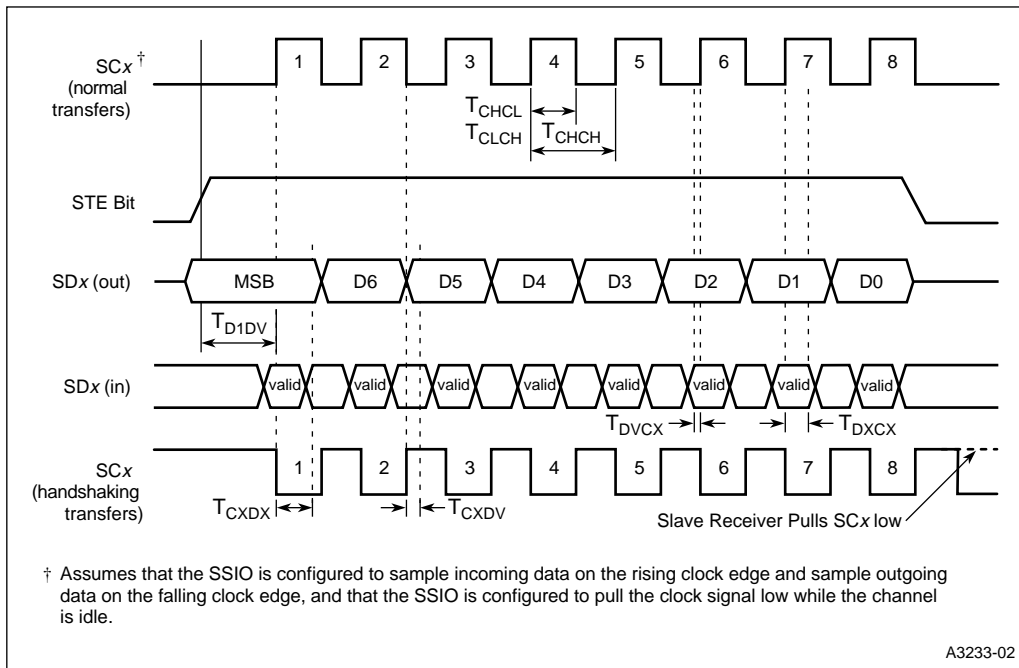

Figure 6. Synchronous Serial Port

5.5 External Clock Drive

Table 11. External Clock Drive

Symbol	Parameter	Min	Max	Units
$1/T_{XLXL}$	Oscillator Frequency	4.0	22	MHz
T_{XLXL}	Oscillator Period (T_{XTAL1})	45.45	200	ns
T_{XHXX}	High Time	$0.35 T_{XTAL1}$	$0.65 T_{XTAL1}$	ns
T_{XLXX}	Low Time	$0.35 T_{XTAL1}$	$0.65 T_{XTAL1}$	ns
T_{XLXH}	Rise Time		10	ns
T_{XHXL}	Fall Time		10	ns

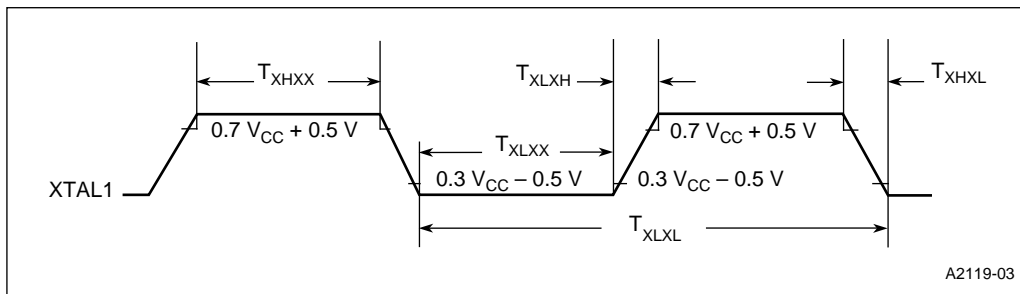

Figure 7. External Clock Drive Waveforms

5.6 Test Output Waveforms

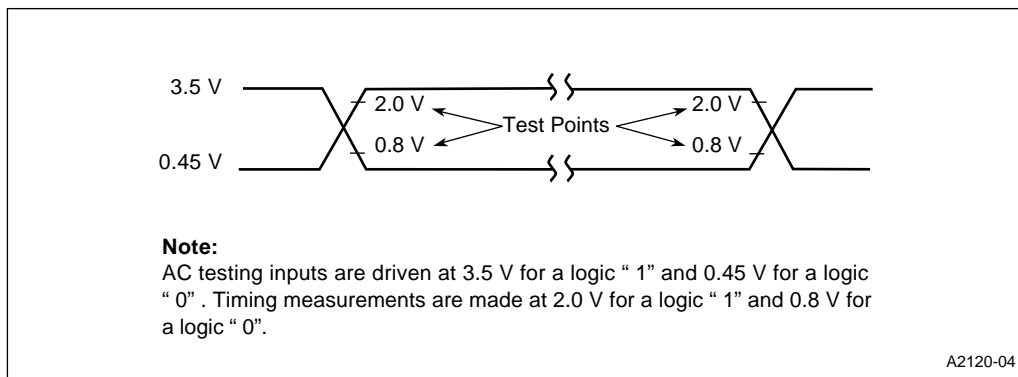

Figure 8. AC Testing Input, Output Waveforms

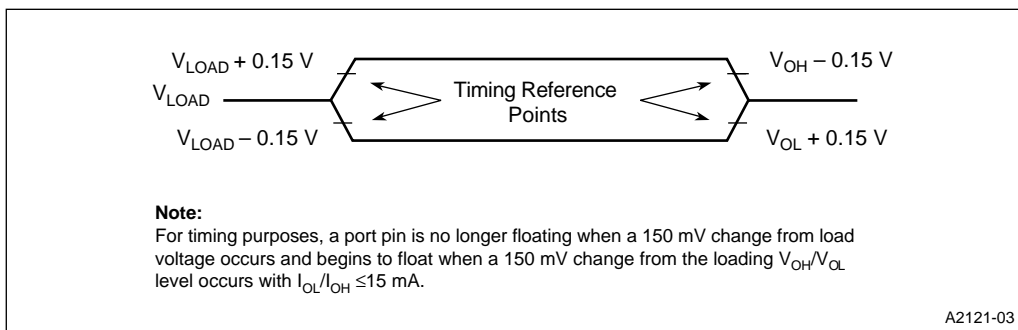

Figure 9. Float Waveforms

6.0 THERMAL CHARACTERISTICS

All thermal impedance data is approximate for static air conditions at 1 watt of power dissipation. Values will change depending on operating conditions and the application. The Intel *Packaging Handbook* (order number 240800) describes Intel's thermal impedance test methodology. The *Components Quality and Reliability Handbook* (order number 210997) provides quality and reliability information.

Table 12. Thermal Characteristics

Package Type	θ_{JA}	θ_{JC}
52-pin PLCC	42°C/W	15°C/W

NOTES:

1. θ_{JA} = Thermal resistance between junction and the surrounding environment (ambient). Measurements are taken 1 ft. away from case in static air flow environment.
 θ_{JC} = Thermal resistance between junction and package surface (case).
2. All values of θ_{JA} and θ_{JC} may fluctuate depending on the environment (with or without airflow, and how much airflow) and microcontroller power dissipation at temperature of operation. Typical variations are $\pm 2^\circ\text{C/W}$.
3. Values listed are at a maximum power dissipation of 0.50 W.

7.0 DESIGN CONSIDERATIONS

The 83C196LC and 83C196LD are pin-compatible replacements for the 87C196JT and 87C196JR microcontrollers with the following exceptions.

- The synchronous serial I/O port was enhanced to provide more flexible communication to other devices; however, it remains compatible with the 87C196JT and JR non-enhanced SSIO.
- The A/D converter was removed to optimize die size.

Follow these recommendations to help maintain hardware and software compatibility between 52-pin, 68-pin, and future microcontrollers.

- **Bus width.** Since the 83C196LC and LD have neither a WRH# nor a BUSWIDTH pin, the microcontrollers cannot dynamically switch between 8- and 16-bit bus widths. Program the CCBs to select 8-bit bus mode.
- **Wait states.** Since the 83C196LC and LD have no READY pin, the microcontrollers cannot rely on a READY signal to control wait states. Program the CCBs to limit the number of wait states (0, 1, 2, or 3).
- **Write cycle during reset.** If the microcontroller is reset during a write cycle, the contents of the external memory device may be corrupted.
- **EPA7.** This function exists in the 83C196LC and LD, but the associated pin is omitted. You can use this channel either as a software timer or to reset the timers.
- **EPA timer reset/write conflict.** If an EPA channel resets the timer at the same time your code writes to the timer, it is indeterminate which action takes precedence. If your code uses an EPA channel to reset a timer, do not write to the timer.
- **Valid time matches.** The timer must increment or decrement to the compare value for a valid match to occur. Writing the compare value to the timer will not cause a match. Resetting the timer also will not cause a match when the compare value is zero.
- **NMI.** Since the 83C196LC and LD have no NMI pin, the nonmaskable interrupt is not supported. Initialize the NMI vector (at location 203EH) to point to a RET instruction. This method provides glitch protection only.



- **I/O port pins.** The following port pins do not exist in the 83C196LC and LD: P0.0–P0.1, P1.4–P1.7, P2.3 and P2.5, P5.1 and P5.4–P5.7, P6.2 and P6.3. Software can still read and write the associated Px_REG, Px_MODE, and Px_DIR registers. Configure the registers for the removed pins as follows:
 - Clear the corresponding Px_DIR bits. (Configures pins as complementary outputs.)
 - Clear the corresponding Px_MODE bits. (Selects I/O port function.)
 - Write either “0” or “1” to the corresponding Px_REG bits. (Effectively ties signals low or high.)
 - Do not use the bits associated with the removed port pins for conditional branch instructions. Treat these bits as reserved.
- **P6.7:4.** A value written to any of the upper four bits of P6_REG (bits 4–7) is held in a buffer until the corresponding P6_MODE bit is cleared, at which time the value is loaded into the P6_REG bit. A value read from a P6_REG bit is the value currently in the register, not the value in the buffer. Therefore, any change to a P6_REG bit can be read only after the corresponding P6_MODE bit is cleared.
- **Reading reserved memory locations.** The 87C196JT and JQ implement a precharged peripheral bus within the microcontroller that returns a logic one when reserved bits are read. The 83C196LC and LD use a driven bus within the microcontroller that returns the last value driven on the peripheral data bus when reserved bits are read.

8.0 83C196LC, 83C196LD ERRATA

There is no known device errata at this time.

9.0 DATASHEET REVISION HISTORY

This datasheet is valid for devices with an “A” at the end of the topside field process order (FPO) number. Datasheets are changed as new device information becomes available. Verify with your local Intel sales office that you have the latest version before finalizing a design or ordering devices.