

Document No.	853-0624
ECN No.	99800
Date of Issue	June 14, 1990
Status	Product Specification
ECL Products	

# 100158

## Shift Matrix

### FEATURES

- Typical propagation delay: 1.9ns
- Typical supply current ( $-I_{EE}$ ): 118mA

### DESCRIPTION

The 100158 contains a combinatorial network which performs the function of an

8-bit Shift Matrix. Three control lines ( $S_n$ ) are internally decoded to define the number of places which an 8-bit word, present at the inputs ( $D_n$ ), is shifted to the right. The shifted word appears on the outputs  $Q_n$ . A Mode Control is provided which, if Low, forces Low all outputs to the left of the one that contains  $D_7$ . This operation is sometimes referred to as low backfill. If M

is High, a circular shift is performed, such that  $D_0$  appears at the output just to the left of the one that contains  $D_7$ . This operation is commonly referred to as barrel shifting.

All unused inputs can be left open due to integrated pull-down resistors.

### PIN DESCRIPTION

PINS	DESCRIPTION
$D_0 - D_7$	Data Inputs
$S_0 - S_2$	Select Inputs
M	Mode Control Input
$Q_0 - Q_7$	Data Outputs

### ORDERING INFORMATION

DESCRIPTION	ORDER CODE
24-Pin Ceramic DIP (400 mils wide)	100158F
24-Pin Ceramic Flat Pack	100158Y
28-Pin PLCC	100158A

### PIN CONFIGURATIONS

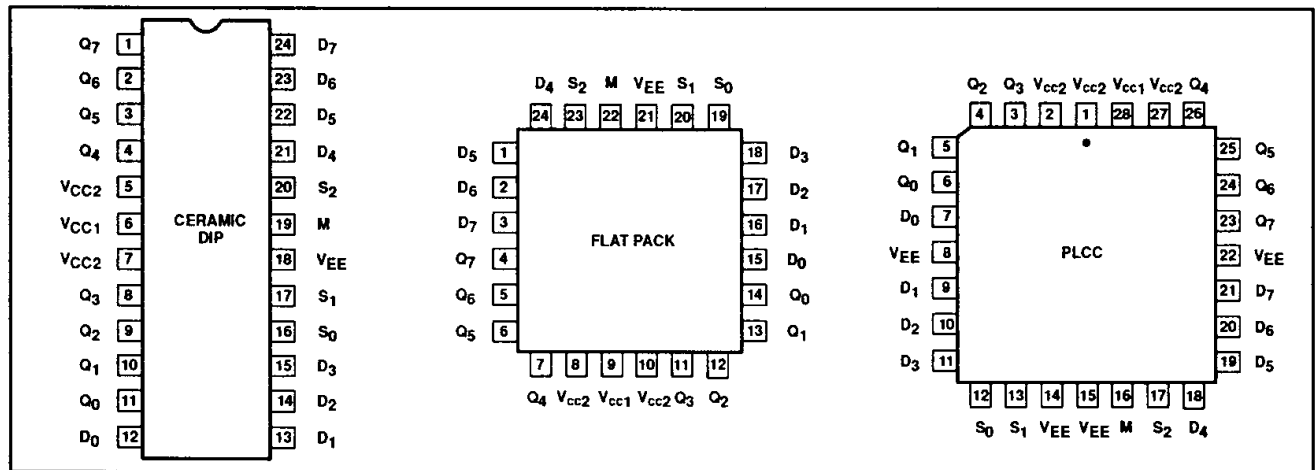

# Shift Matrix

100158

## LOGIC DIAGRAM

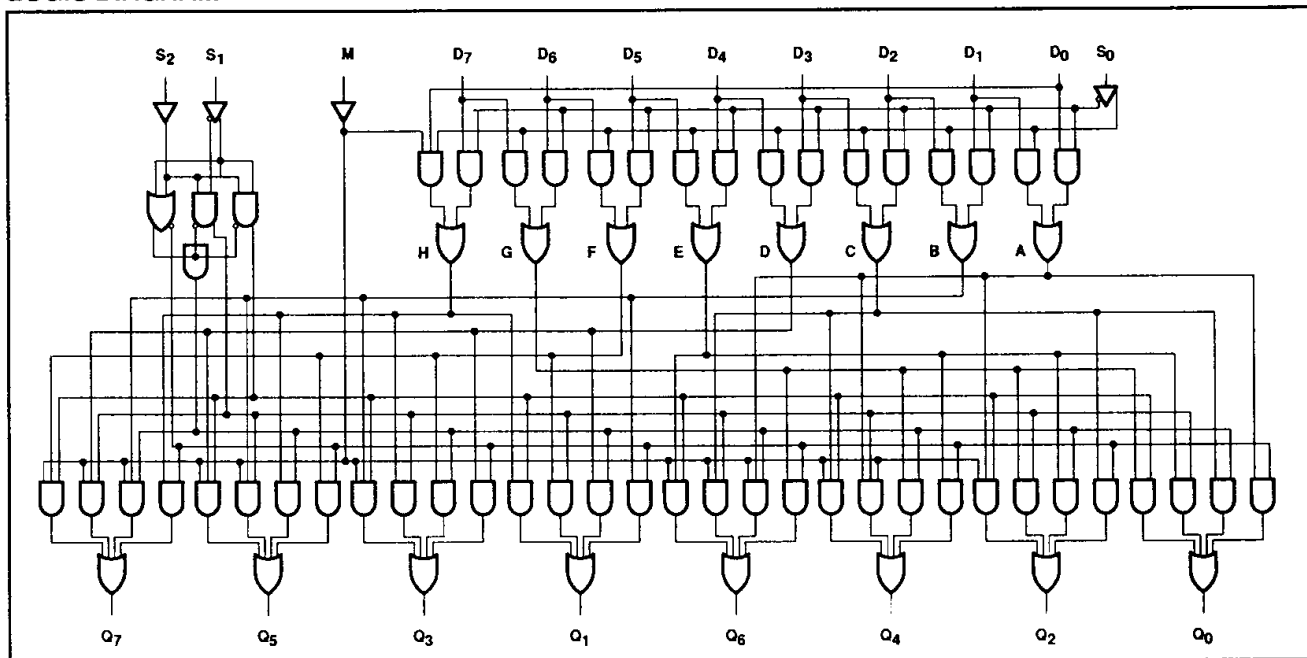

## FUNCTION TABLE

INPUTS				OUTPUTS							
M	S <sub>2</sub>	S <sub>1</sub>	S <sub>0</sub>	Q <sub>7</sub>	Q <sub>6</sub>	Q <sub>5</sub>	Q <sub>4</sub>	Q <sub>3</sub>	Q <sub>2</sub>	Q <sub>1</sub>	Q <sub>0</sub>
X	L	L	L	D <sub>7</sub>	D <sub>6</sub>	D <sub>5</sub>	D <sub>4</sub>	D <sub>3</sub>	D <sub>2</sub>	D <sub>1</sub>	D <sub>0</sub>
L	L	L	H	L	D <sub>7</sub>	D <sub>6</sub>	D <sub>5</sub>	D <sub>4</sub>	D <sub>3</sub>	D <sub>2</sub>	D <sub>1</sub>
L	L	H	L	L	L	D <sub>7</sub>	D <sub>6</sub>	D <sub>5</sub>	D <sub>4</sub>	D <sub>3</sub>	D <sub>2</sub>
L	L	H	H	L	L	L	D <sub>7</sub>	D <sub>6</sub>	D <sub>5</sub>	D <sub>4</sub>	D <sub>3</sub>
L	H	L	L	L	L	L	L	D <sub>7</sub>	D <sub>6</sub>	D <sub>5</sub>	D <sub>4</sub>
L	H	L	H	L	L	L	L	L	D <sub>7</sub>	D <sub>6</sub>	D <sub>5</sub>
L	H	H	L	L	L	L	L	L	L	D <sub>7</sub>	D <sub>6</sub>
L	H	H	H	L	L	L	L	L	L	L	D <sub>7</sub>
H	L	L	H	D <sub>0</sub>	D <sub>7</sub>	D <sub>6</sub>	D <sub>5</sub>	D <sub>4</sub>	D <sub>3</sub>	D <sub>2</sub>	D <sub>1</sub>
H	L	H	L	D <sub>1</sub>	D <sub>0</sub>	D <sub>7</sub>	D <sub>6</sub>	D <sub>5</sub>	D <sub>4</sub>	D <sub>3</sub>	D <sub>2</sub>
H	L	H	H	D <sub>2</sub>	D <sub>1</sub>	D <sub>0</sub>	D <sub>7</sub>	D <sub>6</sub>	D <sub>5</sub>	D <sub>4</sub>	D <sub>3</sub>
H	H	L	L	D <sub>3</sub>	D <sub>2</sub>	D <sub>1</sub>	D <sub>0</sub>	D <sub>7</sub>	D <sub>6</sub>	D <sub>5</sub>	D <sub>4</sub>
H	H	L	H	D <sub>4</sub>	D <sub>3</sub>	D <sub>2</sub>	D <sub>1</sub>	D <sub>0</sub>	D <sub>7</sub>	D <sub>6</sub>	D <sub>5</sub>
H	H	H	L	D <sub>5</sub>	D <sub>4</sub>	D <sub>3</sub>	D <sub>2</sub>	D <sub>1</sub>	D <sub>0</sub>	D <sub>7</sub>	D <sub>6</sub>
H	H	H	H	D <sub>6</sub>	D <sub>5</sub>	D <sub>4</sub>	D <sub>3</sub>	D <sub>2</sub>	D <sub>1</sub>	D <sub>0</sub>	D <sub>7</sub>

**NOTES:**

- H = High voltage level
- L = Low voltage level
- X = Don't care

**ABSOLUTE MAXIMUM RATINGS** V<sub>CC1</sub> = V<sub>CC2</sub> = ground, T<sub>A</sub> = 0°C to +85°C unless otherwise specified:

SYMBOL	PARAMETER	LIMITS	UNIT
V <sub>EE</sub>	Supply voltage range	-7.0 to +0.5	V
V <sub>IN</sub>	Input voltage (V <sub>IN</sub> should never be more negative than V <sub>EE</sub> )	V <sub>EE</sub> to +0.5	V
I <sub>O</sub>	Output source current (continuous)	-55	mA
T <sub>S</sub>	Storage temperature range	-65 to +150	°C
T <sub>J</sub>	Maximum junction temperature	+150	°C

**NOTE:**

Operation beyond the limits set forth in this table may impair the useful life of the device.

## Shift Matrix

100158

## DC OPERATING CONDITIONS

SYMBOL	PARAMETER	TEST CONDITIONS	LIMITS			UNIT
			MIN.	NOM.	MAX.	
$V_{CC1}, V_{CC2}$	Circuit ground		0	0	0	V
$V_{EE}$	Supply voltage		-4.8	-4.5	-4.2	V
$V_{EE}$	Supply voltage when operating with the 10K or the 10KH ECL family		-5.7			V
$V_{IH}$	High level input voltage	$V_{EE} = -4.2V$	-1150			mV
		$V_{EE} = -4.5V$	-1165		-880	
		$V_{EE} = -4.8V$	-1165			
$V_{IL}$	Low level input voltage	$V_{EE} = -4.2V$			-1475	mV
		$V_{EE} = -4.5V$	-1810		-1475	mV
		$V_{EE} = -4.8V$			-1490	mV
$T_A$	Operating ambient temperature range		0	+25	+85	°C

## NOTE:

When operating at other than the specified  $V_{EE}$  voltages (-4.2V, -4.5V, -4.8V), the DC and AC electrical characteristics will vary slightly from their specified values.

**DC ELECTRICAL CHARACTERISTICS**  $V_{CC1} = V_{CC2} = \text{ground}, V_{EE} = -4.8V \text{ to } -4.2V, T_A = 0^\circ\text{C to } +85^\circ\text{C unless otherwise specified}^{1,3,4}$ 

SYMBOL	PARAMETER	TEST CONDITIONS <sup>2</sup>	LIMITS			UNIT	
			MIN.	TYP.	MAX.		
$V_{OH}$	High level output voltage	Inputs at $V_{IHMAX}$ or $V_{ILMIN}$	$V_{EE} = -4.2V$	-1020		-870	mV
			$V_{EE} = -4.5V$	-1025	-955	-880	mV
			$V_{EE} = -4.8V$	-1035		-880	mV
$V_{OHT}$	High level output threshold voltage	Outputs loaded with 50Ω to -2.0V ±0.010V	Apply $V_{IHMIN}$ or $V_{ILMAX}$ to one input at a time. Other inputs at $V_{IHMAX}$ or $V_{ILMIN}$ .	$V_{EE} = -4.2V$	-1030		mV
			$V_{EE} = -4.5V$	-1035		mV	
			$V_{EE} = -4.8V$	-1045		mV	
$V_{OLT}$	Low level output threshold voltage	Apply $V_{IHMIN}$ or $V_{ILMAX}$ to one input at a time. Other inputs at $V_{IHMAX}$ or $V_{ILMIN}$ .	$V_{EE} = -4.2V$			-1595	mV
			$V_{EE} = -4.5V$			-1610	mV
			$V_{EE} = -4.8V$			-1610	mV
$V_{OL}$	Low level output voltage	Inputs at $V_{IHMAX}$ or $V_{ILMIN}$ .	$V_{EE} = -4.2V$	-1810		-1605	mV
			$V_{EE} = -4.5V$	-1810	-1705	-1620	mV
			$V_{EE} = -4.8V$	-1830		-1620	mV
$I_{IH}$	High level input current	One input under test at $V_{IHMAX}$ . Other inputs at $V_{ILMIN}$ .				220	μA
$I_{IL}$	Low level input current	One input under test at $V_{ILMIN}$ . Other inputs at $V_{IHMAX}$ .	0.5				μA
$-I_{EE}$	$V_{EE}$ supply current	All inputs at $V_{IHMAX}$	84	118	205		mA

## NOTES:

- The specified limits represent the worst case values for the parameter. Since these worst case values normally occur at the supply voltage and temperature extremes, additional noise immunity can be achieved by decreasing the allowable operating condition ranges.
- Conditions for testing shown in the tables are not necessarily worst case. For worst case testing guidelines, refer to DC Testing, Chapter 1, Section 3.
- The specified limits shown in the DC electrical characteristics table can be met only after thermal equilibrium has been established. Thermal equilibrium is established by applying power for at least 2 minutes, while maintaining transverse airflow of 2.5 meters/sec (500 linear feet/min) over the device, mounted either in a test socket or on a printed circuit board. Test voltage values are given in the DC operating conditions table.
- The device can function down to  $V_{EE} = -5.7V$ , allowing operation with either the 10K or the 10KH family. Correction factors can be used to calculate new DC limits for the extended  $V_{EE}$  range. For more information, see Chapters 5 and 10, Section 4.

## Shift Matrix

100158

## AC ELECTRICAL CHARACTERISTICS

Ceramic DIP  $V_{CC1} = V_{CC2} = \text{ground}$ ,  $V_{EE} = -4.8\text{V to } -4.2\text{V}$ 

SYMBOL	PARAMETER	TEST CONDITION	LIMITS						UNIT
			$T_A = 0^\circ\text{C}$		$T_A = +25^\circ\text{C}$		$T_A = +85^\circ\text{C}$		
			MIN.	MAX.	MIN.	MAX.	MIN.	MAX.	
$t_{PLH}$ $t_{PHL}$	Propagation delay $D_n$ to $Q_n$	Waveform 1	1.10	3.00	1.10	2.90	1.10	3.10	ns
			1.10	3.00	1.10	2.90	1.10	3.10	ns
$t_{PLH}$ $t_{PHL}$	Propagation delay M to $Q_n$		1.15	4.40	1.25	4.40	1.15	4.70	ns
			1.15	4.40	1.25	4.40	1.15	4.70	ns
$t_{PLH}$ $t_{PHL}$	Propagation delay $S_n$ to $Q_n$		1.70	4.50	1.70	4.50	1.70	4.80	ns
			1.70	4.50	1.70	4.50	1.70	4.80	ns
$t_{TLH}$ $t_{THL}$	Transition time $Q_n$		0.50	2.20	0.50	2.20	0.50	2.20	ns
			0.50	2.20	0.50	2.20	0.50	2.20	ns

## NOTE:

For AC test setup information, see AC Testing, Chapter 2, Section 3.

## AC ELECTRICAL CHARACTERISTICS

Ceramic DIP  $V_{CC1} = V_{CC2} = \text{ground}$ ,  $V_{EE} = -5.2\text{V} \pm 5\%$ 

SYMBOL	PARAMETER	TEST CONDITION	LIMITS						UNIT
			$T_A = 0^\circ\text{C}$		$T_A = +25^\circ\text{C}$		$T_A = +85^\circ\text{C}$		
			MIN.	MAX.	MIN.	MAX.	MIN.	MAX.	
$t_{PLH}$ $t_{PHL}$	Propagation delay $D_n$ to $Q_n$	Waveform 1	1.10	3.00	1.10	2.90	1.10	3.10	ns
			1.10	3.00	1.10	2.90	1.10	3.10	ns
$t_{PLH}$ $t_{PHL}$	Propagation delay M to $Q_n$		1.15	4.40	1.25	4.40	1.15	4.70	ns
			1.15	4.40	1.25	4.40	1.15	4.70	ns
$t_{PLH}$ $t_{PHL}$	Propagation delay $S_n$ to $Q_n$		1.70	4.50	1.70	4.50	1.70	4.80	ns
			1.70	4.50	1.70	4.50	1.70	4.80	ns
$t_{TLH}$ $t_{THL}$	Transition time $Q_n$		0.50	2.20	0.50	2.20	0.50	2.20	ns
			0.50	2.20	0.50	2.20	0.50	2.20	ns

## NOTE:

For AC test setup information, see AC Testing, Chapter 2, Section 3.

## AC ELECTRICAL CHARACTERISTICS

Flat Pack and PLCC  $V_{CC1} = V_{CC2} = \text{ground}$ ,  $V_{EE} = -4.8\text{V to } -4.2\text{V}$ 

SYMBOL	PARAMETER	TEST CONDITION	LIMITS						UNIT
			$T_A = 0^\circ\text{C}$		$T_A = +25^\circ\text{C}$		$T_A = +85^\circ\text{C}$		
			MIN.	MAX.	MIN.	MAX.	MIN.	MAX.	
$t_{PLH}$ $t_{PHL}$	Propagation delay $D_n$ to $Q_n$	Waveform 1	1.10	2.80	1.10	2.70	1.10	2.90	ns
			1.10	2.80	1.10	2.70	1.10	2.90	ns
$t_{PLH}$ $t_{PHL}$	Propagation delay M to $Q_n$		1.15	4.20	1.25	4.20	1.15	4.50	ns
			1.15	4.20	1.25	4.20	1.15	4.50	ns
$t_{PLH}$ $t_{PHL}$	Propagation delay $S_n$ to $Q_n$		1.70	4.30	1.70	4.30	1.70	4.60	ns
			1.70	4.30	1.70	4.30	1.70	4.60	ns
$t_{TLH}$ $t_{THL}$	Transition time $Q_n$		0.50	2.20	0.50	2.20	0.50	2.20	ns
			0.50	2.20	0.50	2.20	0.50	2.20	ns

## NOTE:

For AC test setup information, see AC Testing, Chapter 2, Section 3.

# Shift Matrix

100158

## AC ELECTRICAL CHARACTERISTICS

Flat Pack and PLCC  $V_{CC1} = V_{CC2} = \text{ground}$ ,  $V_{EE} = -5.2V \pm 5\%$

SYMBOL	PARAMETER	TEST CONDITION	LIMITS						UNIT
			$T_A = 0^\circ\text{C}$		$T_A = +25^\circ\text{C}$		$T_A = +85^\circ\text{C}$		
			MIN.	MAX.	MIN.	MAX.	MIN.	MAX.	
$t_{PLH}$ $t_{PHL}$	Propagation delay $D_n$ to $Q_n$	Waveform 1	1.10	2.80	1.10	2.70	1.10	2.90	ns
$t_{PLH}$ $t_{PHL}$	Propagation delay $M$ to $Q_n$		1.15	4.20	1.25	4.20	1.15	4.50	ns
$t_{PLH}$ $t_{PHL}$	Propagation delay $S_n$ to $Q_n$		1.70	4.30	1.70	4.30	1.70	4.60	ns
$t_{TLH}$ $t_{THL}$	Transition time $Q_n$		0.50	2.20	0.50	2.20	0.50	2.20	ns

**NOTE:**

For AC test setup information, see AC Testing, Chapter 2, Section 3.

## AC WAVEFORMS

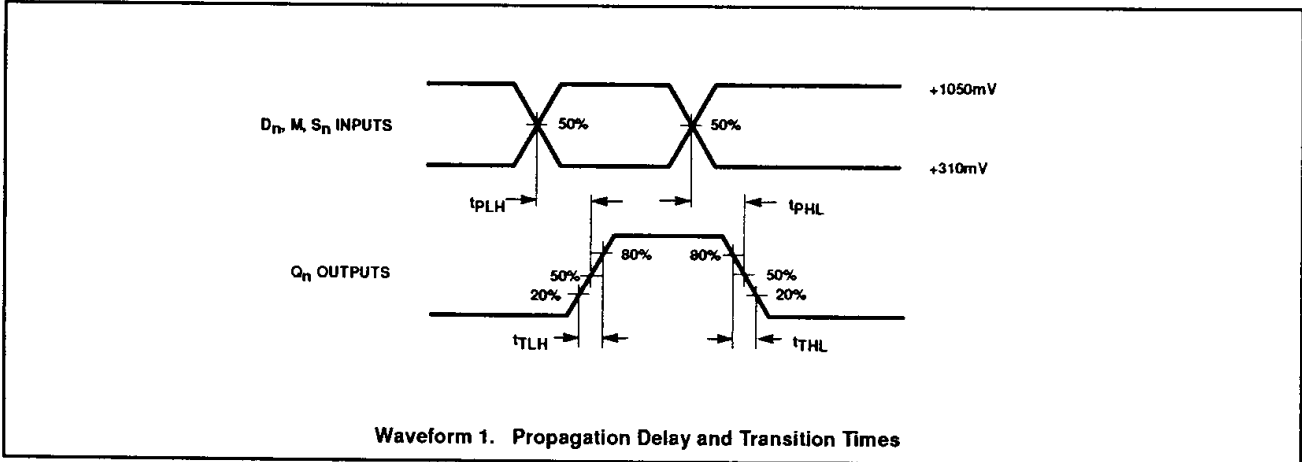

**NOTE:**

All power and signal voltages shifted up 2.0V for AC bench test purposes.