

DBL 5019

LOW POWER NARROW BAND FM IF

The DBL5019 performs single conversion FM reception and consist of an oscillator, mixer, limiting IF amplifier, and meter drive circuitry. These devices are designed for use in FM dual conversion communication eqjpmetrn.

The DBL5019 is similar to the DBL5018 FM IFs, except that a signal strength indicator replaces the scan function controlling driver which is in the DBL5018. The DBL5019 is design for the use of parallel LC components.

This devices also requires fewer external parts than earlier products. The DBL5019 are availavle in dual-in-line and sur-face mount packaging.

FEATURES

- Wide operating Supply Voltage Range : $V_{CC}=2.0$ to $9.0V$
- Input Limiting Voltage Sensitivity of $-3.0dB(2\mu V)$
- Low Drain Current : $I_{CC}=3.2mA$, ($V_{CC}=4.0V$, Squelch off)
- Minimal Drain Current Increase When Squelched
- Signal Strength Indicator : $60dB$ Dynamic Range
- Mixer operating Frequency Up to $100MHz$
- Fewer External Parts Requirde than Earlier Devices

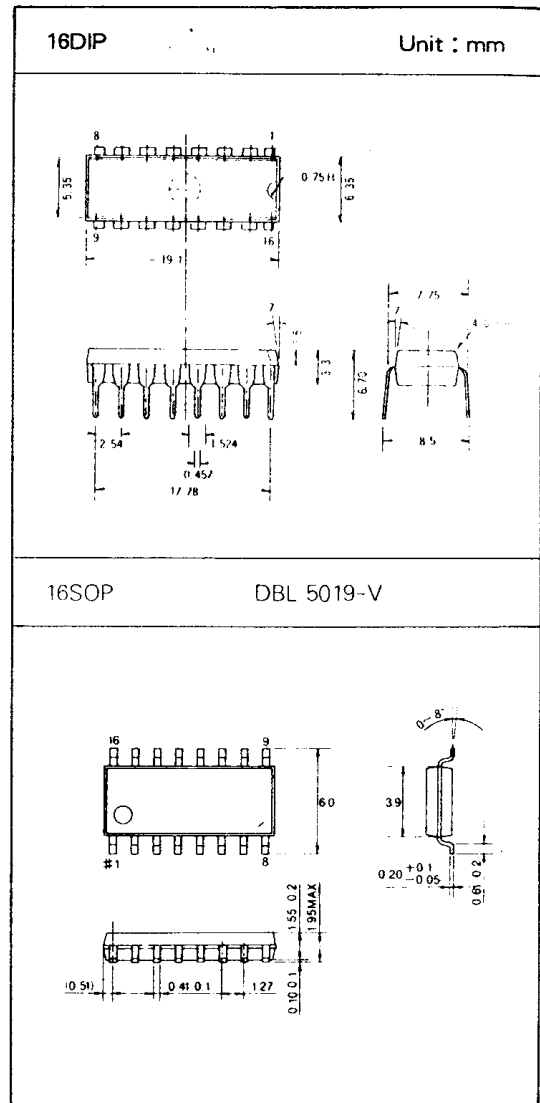

DBL 5019

□ MAXIMUM RATINGS ($T_a = 25^\circ\text{C}$)

Characteristics	Symbol	Rating	Unit
Maximum Supply Voltage	$V_{CC(MAX)}$	10	V
Supply Voltage	V_{CC}	2.0~9.0	V
Detector Input Voltage	$V_{IN(DET)}$	1.0	V_{p-p}
RF Input Voltage ($V_{CC} \geq 4.0V$)	$V_{IN(RF)}$	1.0	V_{rms}
Squelch Input Voltage ($V_{CC} \geq 4.0V$)	V_{SQ}	6.0	V
Mute Function	V_{MUTE}	-0.7~+10	V_{pk}
Mute Sink current	I_{SQ}	50	mA
Operating Temperature	T_{opr}	-20~+70	$^\circ\text{C}$
Storage Temperature	T_{stg}	-65~150	$^\circ\text{C}$

□ ELECTRICAL CHARACTERISTICS

(Unless otherwise specified, $T_a = 25^\circ\text{C}$, $V_{CC} = 4V$, $f_o = 58.1125\text{MHz}$, $f_m = 1\text{KHz}$, $\Delta f = \pm 3\text{KHz}$)

Characteristics	Symbol	Test Condition	Min.	Typ.	Max.	Unit
Squelch Current (No Signal)	I_{ci1}	Squelch off ($V_{i2} = 2V$)	—	3.2	4.2	mA
	I_{ci2}	Squelch on ($V_{i2} = 0V$)	—	3.6	4.8	
	dI_{ci}	Squelch off, $V_{CC} = 2\sim 9V$	—	1.0	2.0	
Detector Output Dc Voltage	V_d	$V_s = 2.0$	0.9	1.6	2.3	V
Filter Output DC Voltage	V_{f1}	No Input Signal	1.5	2.5	3.5	V
Trigger Hysteresis	Hys	—	34	57	80	mV
Input for 12dB SINAD	V_{SIN}	Matched Input	—	1.0	—	μV_{rms}
		unmatched Input	—	5.0	15	
Input for 20dB NQS	V_{NQS}	—	—	3.5	—	μV_{rms}

DBL 5019

□ ELECTRICAL CHARACTERISTICS

(Unless otherwise specified, $T_a=25^\circ\text{C}$, $V_{cc}=4\text{V}$, $f_o=58.1125\text{MHz}$, $f_m=1\text{KHz}$, $\Delta f=\pm 3\text{KHz}$)

Characteristics	Symbol	Test Condition	Min.	Typ.	Max.	Unit
Recovered Audio Output Voltage	AF_0	$V_{rf}=30\text{dBm}$	120	200	320	mVrms
Recovered Audio Drop Voltage Loss	$AF_{1,loss}$	$V_{rf}=-30\text{dBm}$ $V_{cc}=4.0\sim 2.0\text{V}$	-8.0	-1.5	-	dB
Meter Drive Output Voltage (No Modulation)	MV_1 MV_2 MV_3	$V_{rf}=-100\text{dBm}$ $V_{rf}=-70\text{dBm}$ $V_{rf}=-40\text{dBm}$	- 1.1 2.0	0.3 1.5 2.5	0.5 1.9 3.1	V
Filter Amp Gain	A_v (Amp)	$R_f=600\Omega$, $f_s=10\text{KHz}$, $V_{fs}=1.0\text{mVrms}$	47	50	-	dB
Mixer Conversion Gain	$A_v(\text{Mix})$	$V_{rf}=-40\text{dBm}$, $R_1=1.8\text{K}\Omega$	14	20	-	dB
Signal to Noise Ratio	S/N	$V_{rf}=-30\text{dBm}$	36	67	-	dB
Total harmonic Distortion	THD	$V_{rf}=-30\text{dBm}$ $BW=400\text{Hz}\sim 30\text{KHz}$	-	0.6	3.4	%
Detector Output Impedance	Z_o	-	-	450	-	Ω
Detector Output Voltage	DV_o	$V_{rf}=-30\text{dBm}$ No Modulation	-	1.45	-	V
Meter Driver	M_o	$V_{rf}=-100\sim -40\text{dBm}$	-	0.8	-	$\mu\text{A}/\text{dB}$
Meter Driver Dynamic Range	RF_{IN} IF_{IN}	- -	- -	60 80	- -	dB
Mixer Third Order Input Intercept Point	ITO_{NIX}	$f_1=58.125\text{MHz}$ $f_2=58.1375\text{MHz}$	-	-22	-	dBm
Mixer Input Resistance	R_{in}	-	-	3.3	-	$\text{k}\Omega$
Mixer Input Capacitance	C_{in}	-	-	2.2	-	pF

DBL 5019

PIN CONFIGURATION

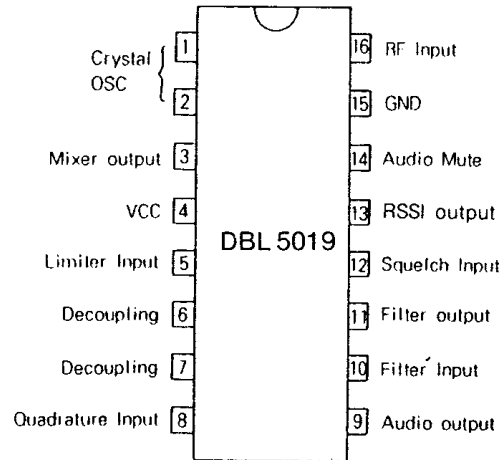

BLOCK DIAGRAM AND TEST CIRCUIT

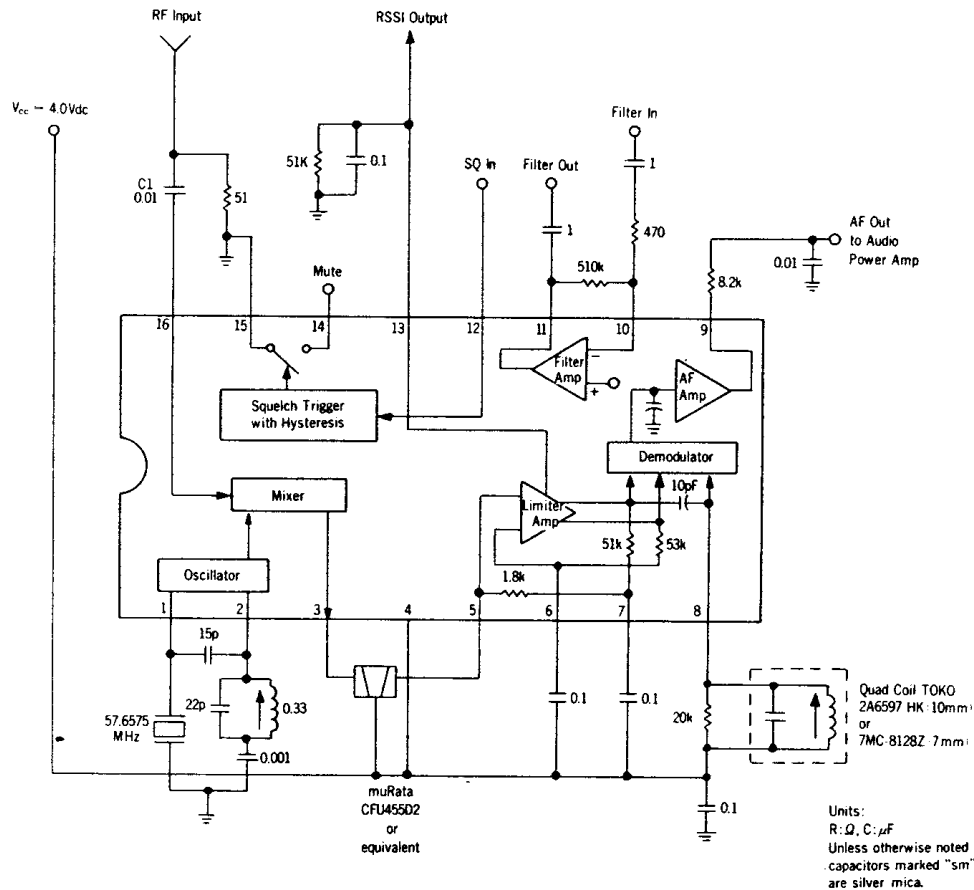

DBL 5019

□ TYPICAL PERFORMANCE CHARACTERISTICS

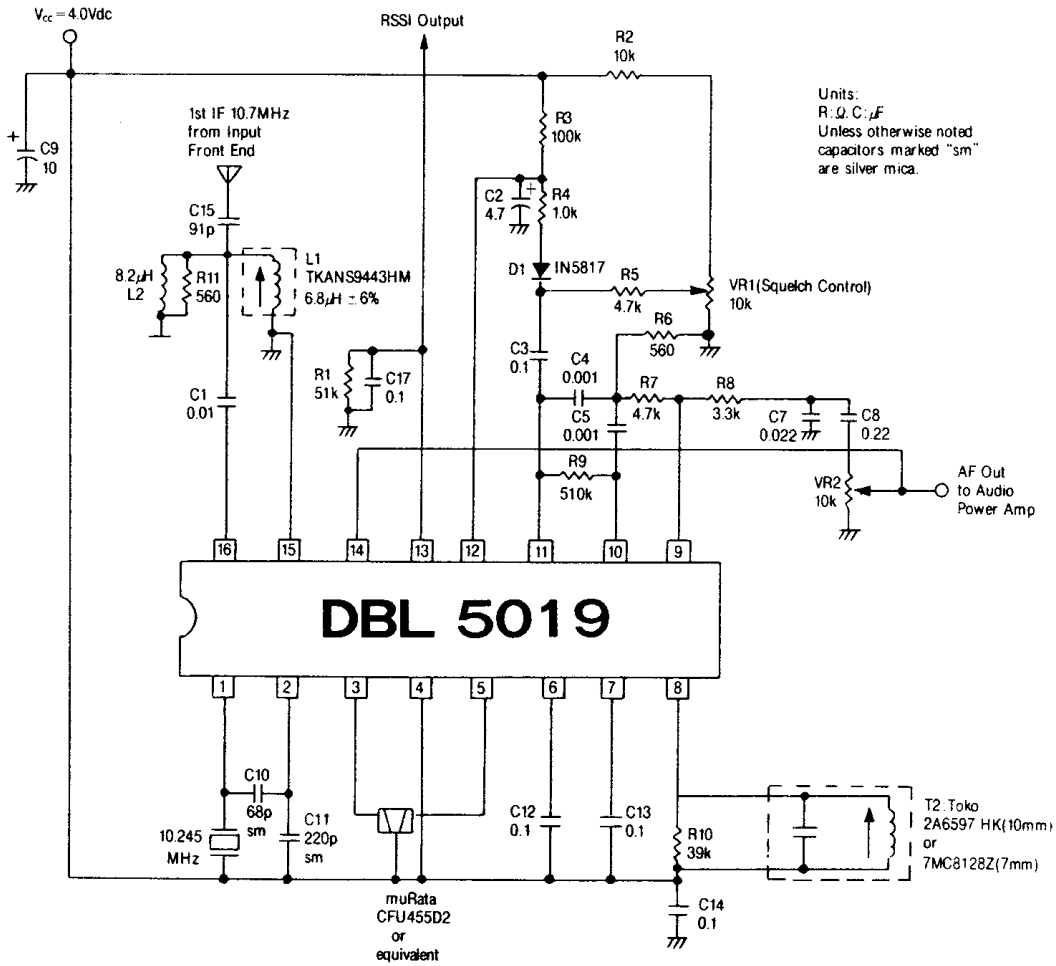

APPLICATION CLRCUIT

TYPICAL PERFORMANCE CHARACTERISTICS

