

DBL 1011

FM/AM IF SYSTEM

The DBL 1011 is a monolithic integrated circuit having the functions of FM/AM IF amplification and AF Detection.

FEATURES

- Operating supply voltage range :
 $V_{CC} = 3V \sim 8V$
- Low supply current: AM = 7mA(Typ.)
FM = 10mA(Typ.)
- Few external parts counts
- Excellent tweet
- Low overload distortion
- Built-in regulator
- Built-in FM/AM mode switch
- Tuning indicator LED driving capability
- Common output for FM/AM

APPLICATIONS

- FM/AM portable radio
- Cassette recorder with radio

MAXIMUM RATINGS

Characteristic	Symbol	Rating	Unit
Supply Voltage	V_{CC}	8	V
Power Dissipation(*)	P_D	750	mW
Operating Temperature	T_{opr}	-25 ~ +75	°C
Storage Temperature	T_{stg}	-55 ~ +150	°C
Lamp Current	I_{LAMP}	10	mA

*Derated above $T_a = 25^\circ C$ in the proportion of $6mW/^\circ C$

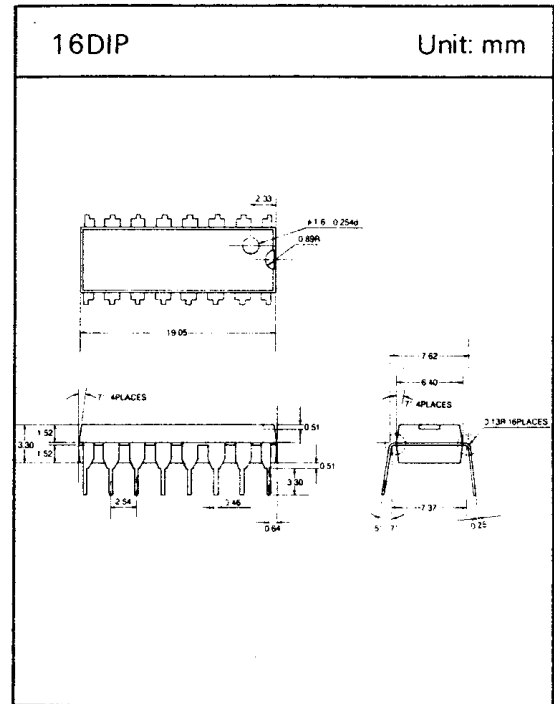

DBL 1011

□ BLOCK DIAGRAM

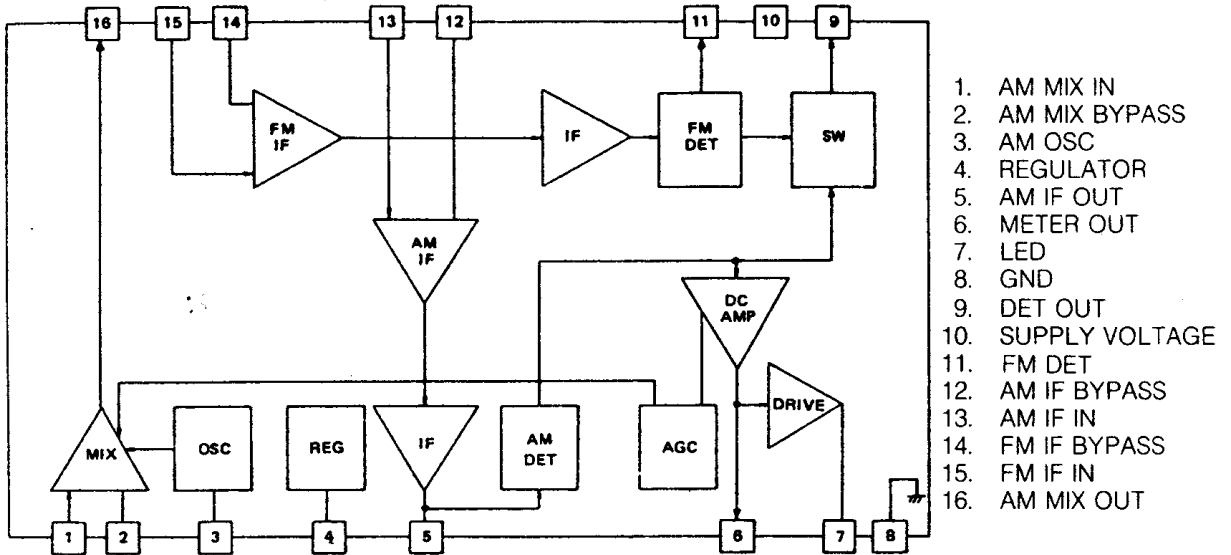

□ TEST CIRCUIT

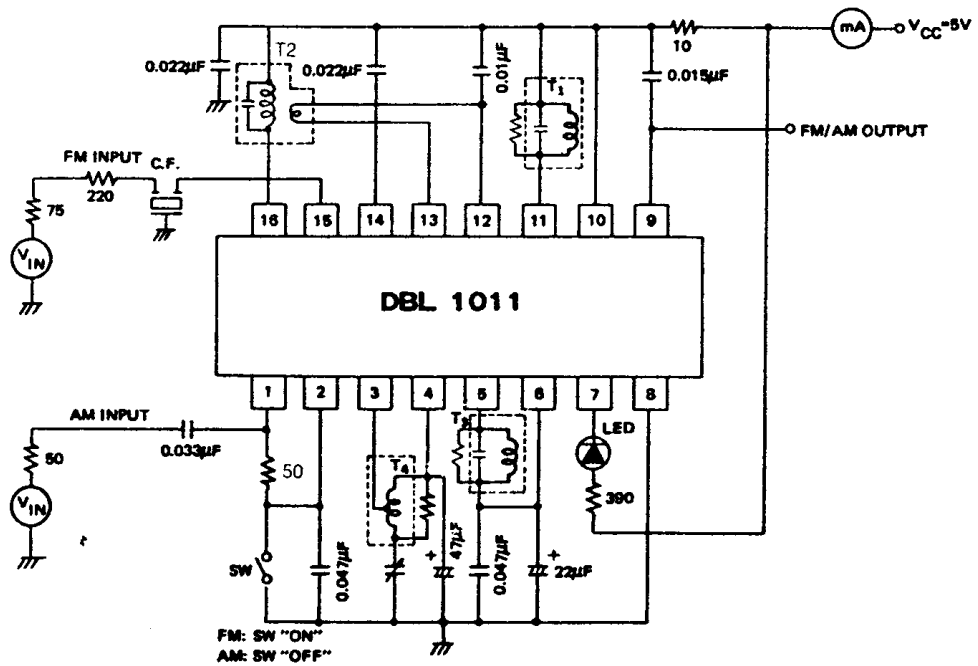

DBL 1011

ELECTRICAL DC CHARACTERISTICS

(Pin voltage at $V_{CC} = 5V$ and no signal)

Pin No.	Typ.		Unit	Pin No.	Typ.		Unit
	AM	FM			AM	FM	
1	1.5	0	V	9	1.4	1.5	V
2	1.5	0	V	10	5	5	V
3	2.3	2.3	V	11	5	5	V
4	2.3	2.3	V	12	1.5	1.5	V
5	1.5	0.9	V	13	1.5	1.5	V
6	1	0.9	V	14	1.5	1.5	V
7	—	—	V	15	1.5	1.5	V
8	0	0	V	16	5	5	V

ELECTRICAL AC CHARACTERISTICS

(Unless otherwise specified, $T_a = 25^\circ C$, $V_{CC} = 5V$, FM : $f = 10.7MHz$, $\Delta f = \pm 22.5KHz$, $f_m = 400Hz$)

AM : $f = 1MHz$, Modulation = 30%, $f_m = 400Hz$)

Characteristics		Symbol	Test Condition	Min.	Typ.	Max.	Unit
F M	Quiescent Current	I_{CCQ}	—	—	10	15	mA
	Input Limiting Sensitivity	$V_{IN(lim)}$	-3dB Limiting	—	40	46	$dB\mu$
	Signal to Noise Ratio	S/N	$V_{IN} = 80dB\mu V$	—	65	—	dB
	Recovered Output Voltage	V_{OD}	$V_{IN} = 66dB\mu V$	57	85	114	mVrms
	Total Harmonic Distortion	THD	$V_{IN} = 80dB\mu V$	—	0.05	—	%
	Meter Drive Voltage	V_M	$V_{IN} = 100dB\mu V$	1.6	1.75	1.9	V
	Lamp ON Sensitivity	V_{LAMP}	$I_{LAMP} = 1mA$	—	46	52	$dB\mu$
	AM Rejection Ratio	AMR	$V_{IN} = 80dB\mu V$	—	38	—	dB
A M	Quiescent Current	I_{CCQ}	—	—	7	10	mA
	Voltage Gain	G_V	$V_{IN} = 26dB\mu V$	20	30	60	mVrms
	Signal to Noise Ratio	S/N	$V_{IN} = 60dB\mu V$	—	47	—	dB
	Recovered Output Voltage	V_{OD}	$V_{IN} = 60dB\mu V$	65	95	125	mVrms
	Total Harmonic Distortion	THD	$V_{IN} = 60dB\mu V$	—	1	—	%
	Meter Drive Voltage	V_M	$V_{IN} = 100dB\mu V$	1.6	1.75	1.9	V
	Lamp ON Sensitivity	V_{LAMP}	$I_{LAMP} = 1mA$	—	32	—	$dB\mu$
Local OSC Stop Voltage	V_{LAMP}	$R_{DUMP} = \infty$	—	1.5	—	$K\Omega$	
Pin 9 Output Resistance	R_{O9}	$f = 1KHz$	—	3	—	$K\Omega$	

DBL 1011

COIL DATA(for test circuit)

1. FM Detector Coil(T₁)

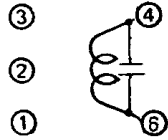

Bottom View

Item	C _O (pF)	f(MHz)	Q _O	Turns
Pin No.	4-6	—	4-6	4-6
Value	47	10.7	150	14

Wire : 0.12mm ϕ

2. AM Mix. Output Coil(T₂)

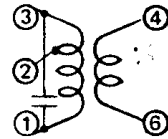

Bottom View

Item	C _O (pF)	f(KHz)	Q _O	Turns		
Pin No.	1-3	—	1-3	1-2	2-3	4-6
Value	180	455	110	90	62	8

Wire : 0.07mm ϕ

3. AM Detector Coil(T₃)

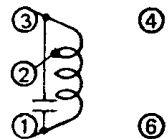

Bottom View

Item	C _O (pF)	f(KHz)	Q _O	Turns
Pin No.	1-3	—	1-3	1-3
Value	180	455	110	152

Wire : 0.07mm ϕ

4. AM Oscillator Coil(T₄)

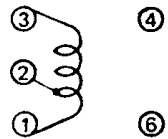

Bottom View

Item	L(μ H)	f(KHz)	Q _O	Turns	
Pin No.	1-3	—	1-3	1-2	2-3
Value	288	796	120	13	75

Wire : 0.08mm ϕ

TYPICAL PERFORMANCE CHARACTERISTICS(0dB = 85mVrms)

1. FM Characteristics

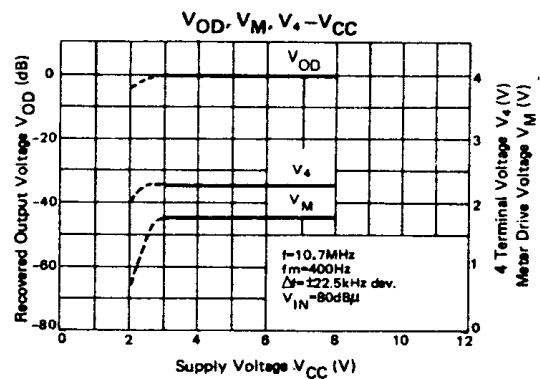
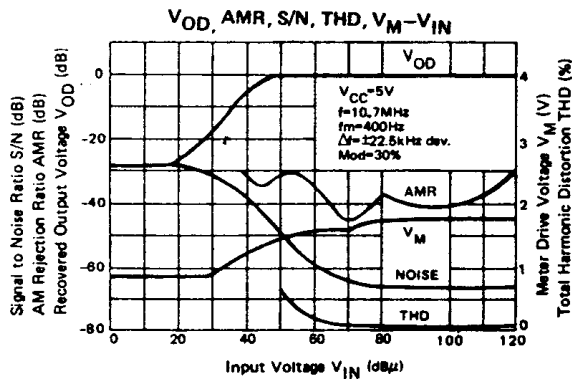

DBL 1011

TYPICAL PERFORMANCE CHARACTERISTICS(continued)

2. AM Characteristics

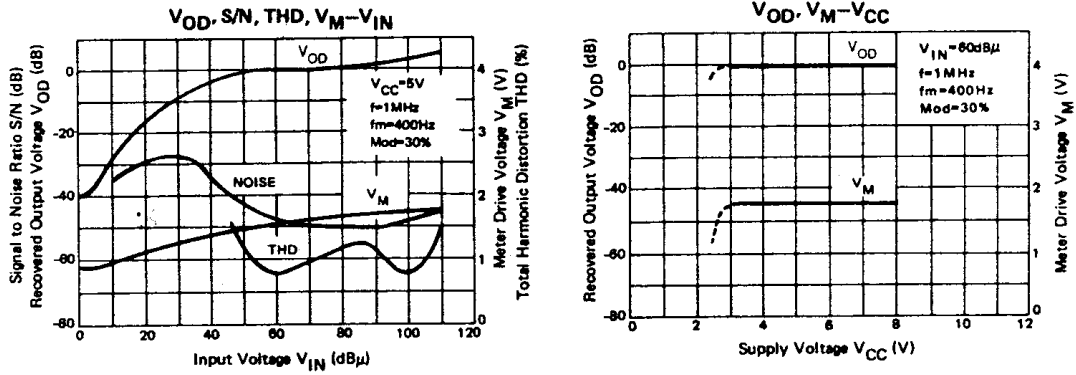

APPLICATION CIRCUIT

