

**SHARP**

### 1. General Description

The IR3M02 is an upgraded version of the IR9494 Pulse Width Modulation Type Switching Regulator Control IC with the added feature of low-voltage error preventive circuit. The IR9494 TL-494 and MB-3759 are all pin compatible.

### 2. Pin Configuration

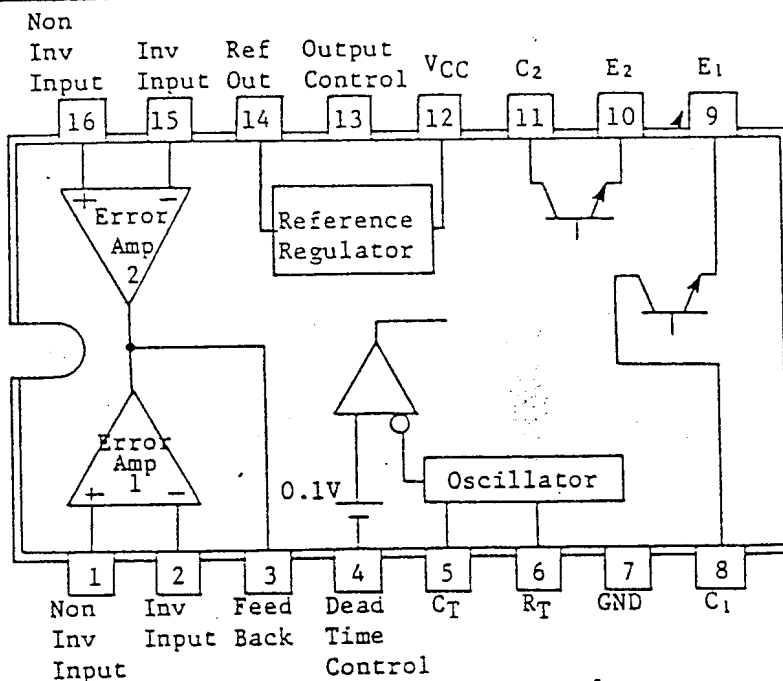

### 3. Maximum Ratings

Parameter	Symbol	Rating	Unit	Remarks
Supply Voltage	V <sub>CC</sub>	41	V	
Input Voltage	V <sub>I</sub>	V <sub>CC</sub> + 0.3	V	Pin 1, 2, 15, 16
Output Voltage	V <sub>C</sub>	41	V	Pin 3, 11
Output Current	I <sub>C</sub>	250	mA	"
Power Dissipation (25°C)	P <sub>C</sub>	1000	mW	Derating ratio 10 mW/°C (T <sub>a</sub> > 25°C)
Operating Temperature Range	T <sub>opr</sub>	-25 ~ +85	°C	
Storage Temperature Range	T <sub>stg</sub>	-65 ~ +150	°C	

**SHARP**4. Recommended Operating Conditions

Parameter	Symbol	Rating			Unit	Remarks
		Min.	Typ.	Max.		
Supply Voltage	V <sub>CC</sub>	7	15	40	V	
Input Voltage	V <sub>I</sub>	-0.3		V <sub>CC</sub> -2	V	
Output Voltage	V <sub>C</sub>			40	V	
Output Current	I <sub>C</sub>	5	100	200	mA	
Output Current on Reference Voltage	I <sub>REF</sub>		5	10	mA	
Outgoing Current	I <sub>OSO</sub>			2	mA	Outgoing into Pin 3
Incoming Current	I <sub>OSI</sub>			0.3	mA	Incoming into Pin 3
Timing Capacitance	C <sub>T</sub>	470		68000	pF	
Timing Resistance	R <sub>T</sub>	1.8		500	KΩ	
Oscillator Frequency	f	1		300	KHz	

5. Electrical Characteristics(V<sub>CC</sub>=15V, T<sub>a</sub>=25°C)

Parameter	Symbol	Rating			Unit	Conditions
		Min.	Typ.	Max.		
Reference Voltage Source						
Output Voltage	V <sub>REF</sub>	4.75	5.0	5.25	V	I <sub>O</sub> =1mA
Input Stability			2	25	mV	7V ≤ V <sub>CC</sub> ≤ 40V
Output Stability			-1	-15	mV	1mA ≤ I <sub>O</sub> ≤ 10mA
Thermal Stability			0.3	1.5	%	-25°C ≤ T <sub>a</sub> ≤ 85°C
Short-circuit Output Current	I <sub>REF</sub>	15	40		mA	
Output Inhibit Voltage on Low-Voltage Supply			4.3		V	
Above Hysteresis Width			0.3		V	

**SHARP**

Parameter	Symbol	Rating			Unit	Conditions
		Min.	Typ.	Max.		
Oscillator Circuit						
Frequency	f	36	40	44	KHz	$R_T=30K\Omega$ , $C_T=1000pF$
Frequency Setting Accuracy			$\pm 3$		%	$V_{CC}$ , $C_T$ , $R_T$ , $T_a$ fixed
Frequency Input Stability			$\pm 0.1$		%	$7V \leq V_{CC} \leq 40V$
Frequency Thermal Stability				3	%	$-25^\circ C \leq T_a \leq 85^\circ C$
Halt Time Setting Circuit						
Input Bias Current	$I_B$		-2	-10	$\mu A$	$0 \leq V_I \leq 5.25V$
Output Maximum Duty		40	45		%	$V_I=0$
Input Voltage (Pin 4)	$V_I$		3.0	3.3	V	0% Duty
		0			V	Max. Duty
Error Amp						
Input Offset Voltage	$V_{IO}$		2	10	mV	$V_O(\text{pin } 3)=2.5V$
Input Offset Current	$I_{IO}$		25	250	nA	$V_O(\text{pin } 3)=2.5V$
Input Bias Current	$I_B$		-0.2	-1.0	$\mu A$	$V_O(\text{pin } 3)=2.5V$
Common Input Voltage Range	$V_{CM}$	-0.3		$V_{CC}-2$	V	$7V \leq V_{CC} \leq 40V$
Open Voltage Gain	$A_v$	70	95		dB	$0.5V \leq V_O \leq 3.5V$
GB Product	G·B		800		KHz	
Common Signal Rejection Ratio	CMR	65	80		dB	$V_{CC}=40V$
Output Sink Current	$I_{OSi}$	0.3	0.7		mA	$-5V \leq V_{ID} \leq -15mV$ , $V_O=0.7V$
Output Source Current	$I_{OSO}$	-2	-10		mA	$15mV \leq V_{ID} \leq 5V$ , $V_O=3.5V$

**SHARP**

Parameter	Symbol	Rating			Unit	Conditions
		Min.	Typ.	Max.		
Output Circuit						
Off-state Corrector Current				100	$\mu\text{A}$	$V_{CC}=40\text{V}, V_C=40\text{V}$
Off-state Emitter Current				-100	$\mu\text{A}$	$V_{CC}=V_C=40\text{V}, V_E=0$
Output Saturation Voltage	Common Emitter	$V_{CE\text{ sat}}$	1.1	1.3	V	$V_E=0, I_C=200\text{mA}$
	Common Collector	$V_{CE\text{ sat}}$	1.5	2.5	V	$V_C=15\text{V}, I_E=-200\text{mA}$
Output Control Input Current (Pin 13)			1.3	3.5	mA	$V_I=V_{REF}$
PWM Comparator						
Input Voltage (Pin 3)	$V_I$		4	4.5	V	0% Duty
Input Current (Pin 3)		0.3	0.7		mA	$V_O(\text{pin } 3)=0.7\text{V}$
Whole Circuitry				15	mA	
Static Supply Current	$I_{CC1}$		7	12	mA	$V(\text{pin } 6)=V_{REF}, I/O \text{ Pin Open}$
Supply Current (Standard Connection)	$I_{CC2}$		8		mA	$V_{4-7}=2\text{V}$ Fig.1
Output Switching Characteristics						
Rise Time	trc		100	200	ns	Common Emitter, $R_L=68\Omega$ Fig.2
Fall Time	tfc		25	100	ns	
Rise Time	tre		100	200	ns	Common Collector $R_L=68\Omega$ Fig.3
Fall Time	tfe		40	100	ns	

**SHARP**

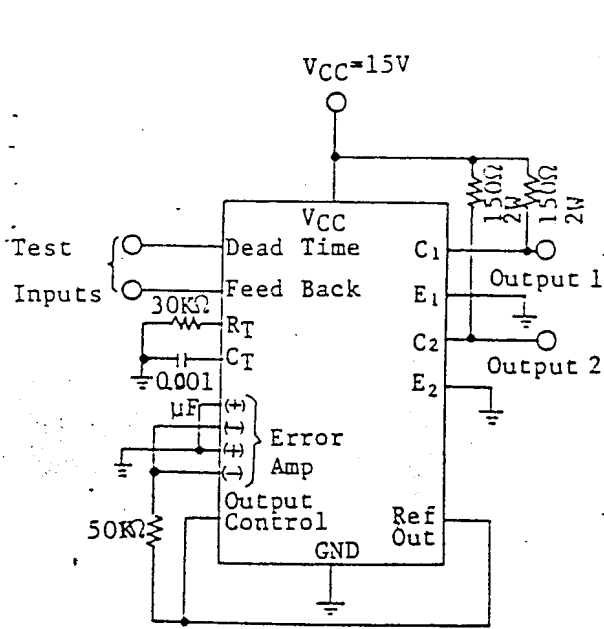

(Fig. 1)

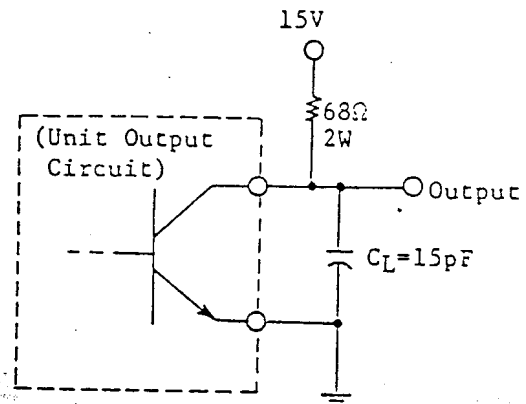

(Fig. 2)

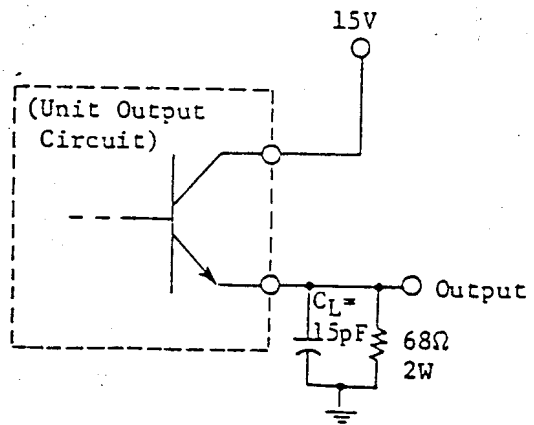

(Fig. 3)

**SHARP**

## 1. Package Specification

Refer to Drawing No. AA640-025.

## 2. Markings

## 2-1. Marking contents

- (1) Product name: IR3M02
- (2) Company name: **SHARP**
- (3) Date code:

(Example) 2 2 6 A --- Indicates the product was manufactured in the 1st week of June, 1982.

└─── Denotes the production week. (A, B, C, D, E)

└─── Denotes the production month. (1, 2, 3, ..... 9, X, Y, Z)

└─── Denotes the last digit of the year.

└─── Denotes the I.D. No.

## 2-2. Marking positions

Refer to Drawing No. AA640-025.

## 2-3. Marking color

Silver

## 3. Crating Specification

## 3-1. Crating materials

Crating parts	Parts materials	Purposes
Tube	Conductive plastic ( 25 devices per tube)	Device crating
Stopper	Plastic	Device fixing
Label	Paper	Indication of product name, quantity and production date.
Inside crating case	Cardboard	Inside crating of tubes
Outside crating case	Cardboard	Outside crating of tubes

**SHARP**

### 3-2. External view of crated products

Refer to Drawing No. BJ023-00.

#### Precaution for unpacking

- 1) Unpacking should be done on the stand as well as a human body treated with anti-ESD.
- 2) Conductive treatment or anti-ESD treatment is given to a tube. Use the equivalent tube, if it is changed to another one.
- 3) Be sure to fix two stoppers to both ends of a tube when storage to prevent the devices from slipping.

**SHARP**

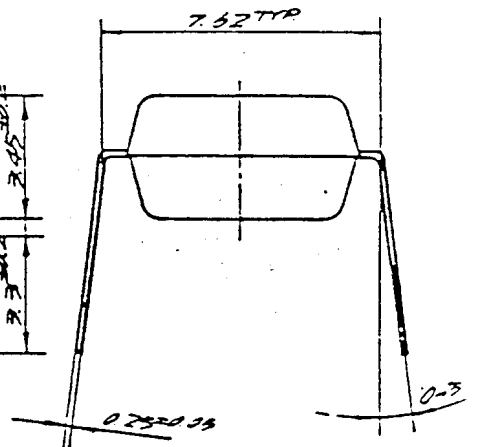
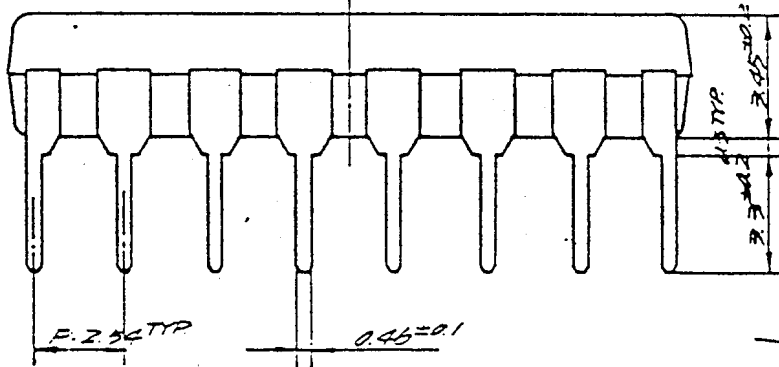
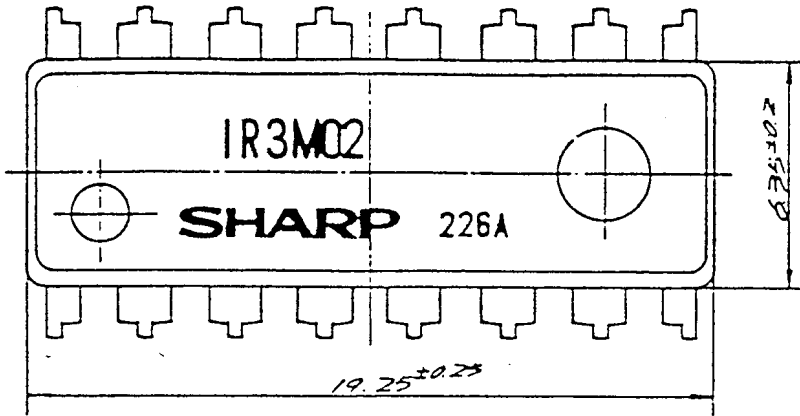

適用場所	尺 寸 SCALE	單位 UNIT	△
APPLICABLE MODEL	5/1	1 = 1/1 mm	△
IR3M02			改訂日 DATE: 改訂記事 REVISE 用者 CHECK
厚さ THICKNESS	数量 PIECES	材質 MATERIAL	比色 FINISH
			名 稱 NAME
			DPT16DP
日付 DATE		Sn plating	コ ー ド CODE
設計 DRAW	製図 TRACE	検査 CHECK	承認 APPROVE
		SHARP CORPORATION	図 番 DRAWING No
			AA 640-025



SHARP

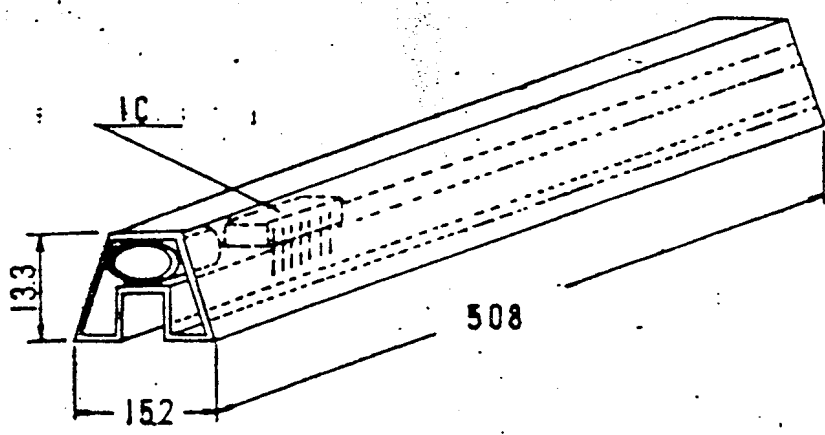
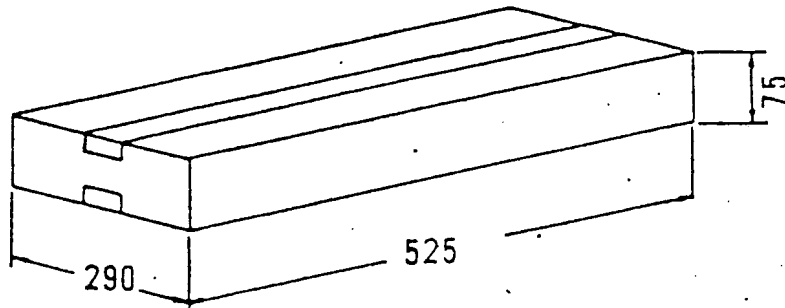

△		△		適用機種		名 稱		IC	
DATE		REVISION		MODEL		NAME		PACKING CASE	
IR3M02		板 厚		尺 寸		角 度		員 數	
MATERIAL		FINISH		THICKNESS		SCALE		PIECES	
								UNIT	
								M	
								CODE	
設計		製圖		承認		DATE		57 . 9 . 7	
DESIGN		DRAW		CHECK		SHARP CORPORATION		DRAWING NO. 81023-00	