

AN3296, AN3296S

Synchronous Separation/AFC ICs

■ Overview

The AN3296 and AN3296S are the ICs designed for video sync. signal processing circuit.

■ Features

- Built-in horizontal and vertical sync. signal separator and generator.
- Adjustment-free horizontal AFC free-running frequency.
- Built-in sync. signal detector.

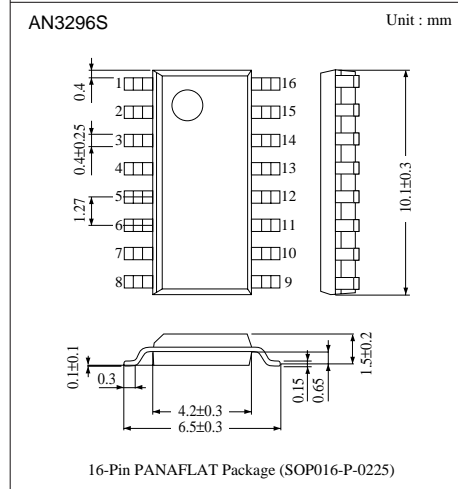
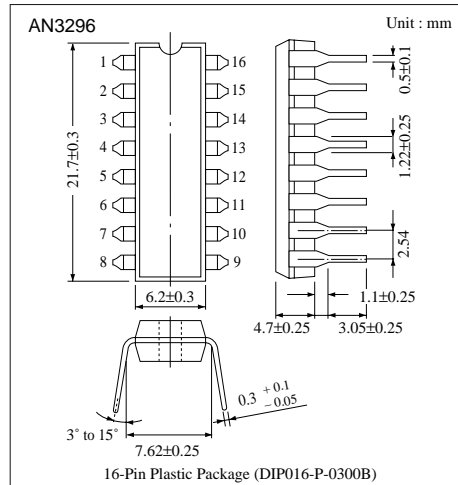

■ Block Diagram

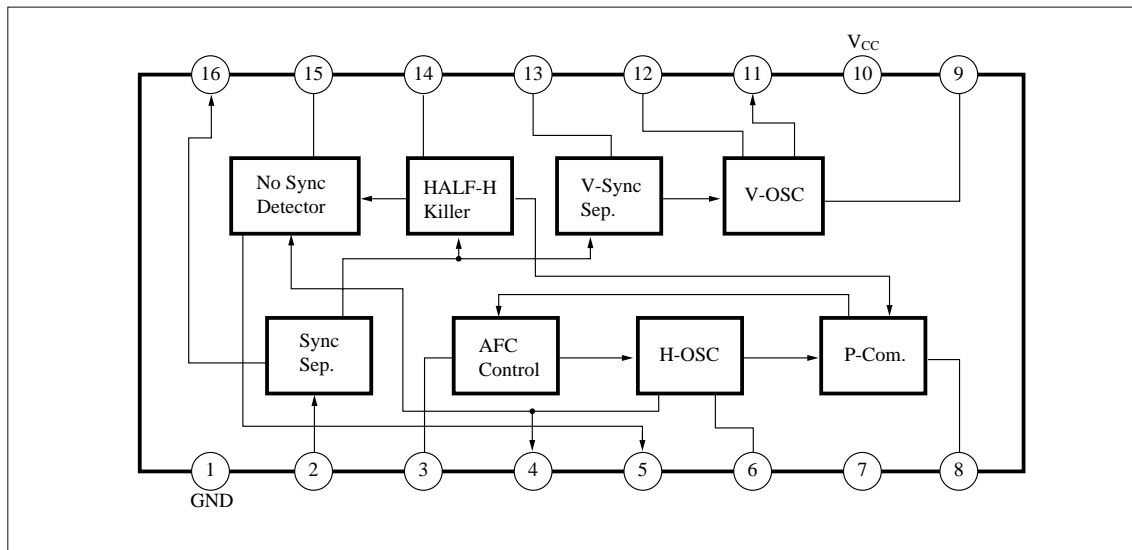

■ Absolute Maximum Ratings (Ta=25°C)

Parameter	Symbol	Rating	Unit
Supply voltage	V _{CC}	6	V
Power dissipation (Ta=70°C)	P _D	80	mW
Operating ambient temperature	T _{opr}	-20 to + 70	°C
Storage temperature	AN3296	T _{stg}	°C
	AN3296S		

■ Recommended Operating Range (Ta =25°C)

Parameter	Symbol	Range
Operating supply voltage range	V _{CC}	4.5V to 5.5V

■ Electrical Characteristics (Ta=25°C)

Parameter	Symbol	Condition	min	typ	max	Unit
Total current	I _{tot}	V _{CC} = 5V	3	—	9	mA
SYNC output phase	φ _S	V _{CC} = 5V	0	—	1	μs
SYNC width	τ _S	V _{CC} = 5V	3	—	5.5	μs
V free-oscillation frequency	f _{VF}	At no input signal	40	—	60	Hz
V _D output phase	φ _{VD}	V _{CC} = 5V	5	—	17	μs
V _D width	τ _{VD}	V _{CC} = 5V	0.4	—	1	ms
SYNC DET output (1)	NSD ₁	Input signal 0dB (1V _{PP})	0	—	0.5	V
SYNC DET output (2)	NSD ₂	Input signal -25dB	4.5	—	5	V
H free-oscillation frequency	f _{HF}	At no input signal	6	—	8	kHz
AFC control characteristic	β _{AFC}	Current = 0, 100μA	100	—	150	Hz/μA
AFC lock range	AFC	Input signal 0.3V _{PP}	14.7	—	16.8	kHz
H _D output phase	φ _{HD}	V _{CC} = 5V	-1.2	—	-0.2	μs
H _D width	τ _{HD}	V _{CC} = 5V	7.5	— </td <td>10.5</td> <td>μs</td>	10.5	μs

■ Application Circuit

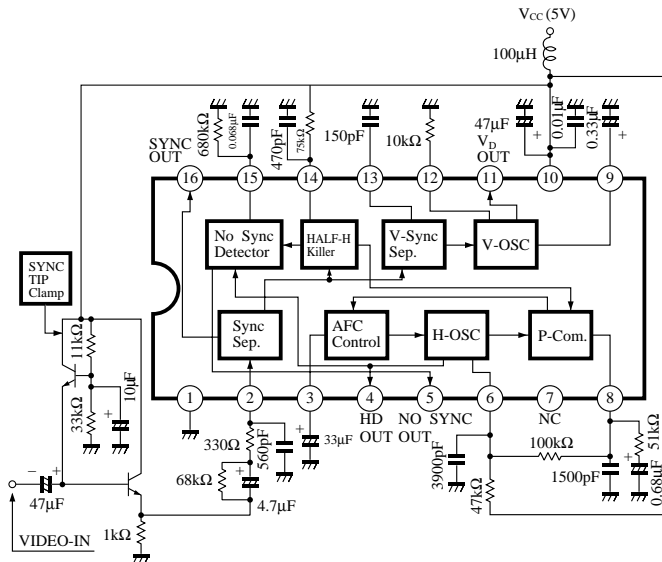

Note) For external C (3900pF) and R (47kΩ) at the Pin6 use high-accuracy parts.
 Recommended parts (Model by PANASONIC) C : ECQP1H392GZ R : ERO-25CKF4702