

SANYO

No. 3853A

LA8632, LA8632M**Low-voltage, Low-current Compander**

OVERVIEW

The LA8632 and LA8632M are low-voltage, low-current compander ICs for battery-powered, cordless telephone applications.

The LA8632 and LA8632M feature a good signal-to-noise ratio and a high dynamic range at voice-signal frequencies. The output compression is given by $V_o = 0.5 \log V_i$, and the expansion, by the inverse operation.

The LA8632 and LA8632M also feature an FSK comparator for receiving FSK-modulated digital data, a microphone amplifier, selectable intercom or telephone operation expander outputs, and an output mute control.

The LA8632 and LA8632M operate from a 2.4 to 6.0 V supply and are available in 24-pin DIPs and 24-pin MFPs.

FEATURES

- Low-voltage operation and low-power consumption
- On-chip frequency-shifted keyed (FSK) comparator
- On-chip microphone amplifier with audio limiter and mute option
- Expander output analog switch for telephone or intercom operation
- Low-power, standby mode
- 2.4 to 6.0 V supply
- 24-pin DIP and 24-pin MFP

PINOUT

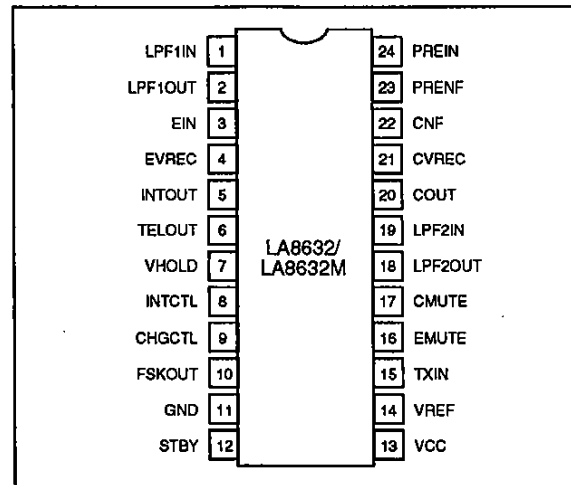

PACKAGE DIMENSIONS

Unit: mm

3067-DIP24S (LA8632)

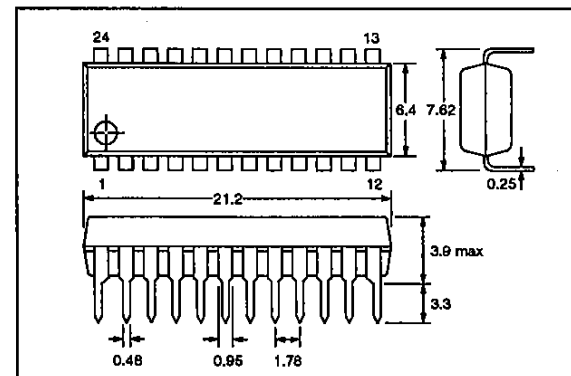

3112-MFP24S (LA8632M)

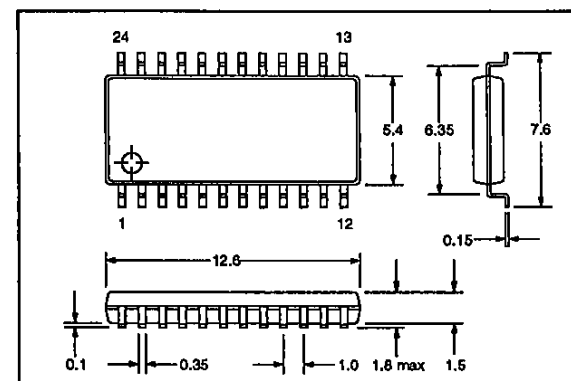

SANYO Electric Co., Ltd. Semiconductor Business Headquarters
TOKYO OFFICE Tokyo Bldg., 1-10, 1 Chome, Ueno, Taito-ku, TOKYO, 110 JAPAN

6152TS No. 3853-1/9

BLOCK DIAGRAM

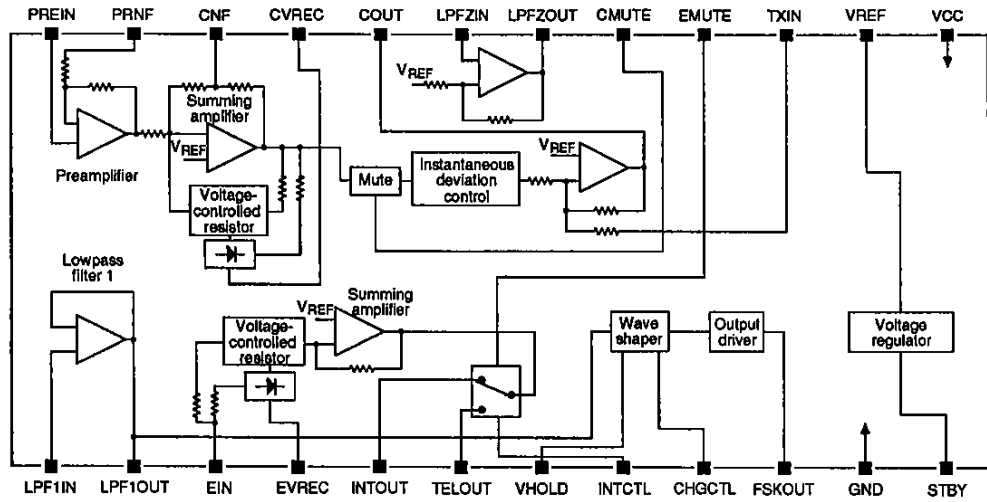

PIN DESCRIPTION

Number	Name	Equivalent circuit	Description
1	LPF1IN		Lowpass filter 1 buffer amplifier (class A) input. Nominal voltage is 1.2 V.
2	LPF1OUT		Lowpass filter 1 buffer amplifier (class A) output. Nominal voltage is 1.2 V.
3	EIN		Expander voltage-to-current converter input. Nominal voltage is 1.5 V.
4	EVREC		Expander full-wave rectifier
5	INTOUT		Expander intercom op-amp (class AB) output. Nominal voltage is 1.5 V.

LA8632, LA8632M

Number	Name	Equivalent circuit	Description
6	TELOUT		Expander telephone op-amp (class AB) output. Nominal voltage is 1.5 V.
7	VHOLD		Voltage hold capacitor connection. Nominal voltage is 1.2 V.
9	CHGCTL		Charge control input. Nominal voltage is V_{CC} .
10	FSKOUT		Frequency-shifted keyed comparator, open-collector output
8	INTCTL		Intercom control input. Nominal voltage is 3 V.
11	GND		Ground
12	STBY		Standby control input. Nominal voltage is 1.5 V.
14	VREF		Reference voltage amplifier (class B) capacitor connection. Nominal voltage is 1.5 V.
13	VCC		Voltage supply
15	TXIN		Transmit data input. Nominal voltage is 1.5 V.
20	COUT		Comander amplifier (class AB) output. Nominal voltage is 1.5 V.

LA8632, LA8632M

Number	Name	Equivalent circuit	Description
16	EMUTE		Expander mute control input. Nominal voltage is 3 V.
17	CMUTE		Compressor mute control input. Nominal voltage is 3 V.
18	LPF2OUT		Lowpass filter 2 buffer amplifier (class AB) output. Nominal voltage is 1.5 V.
19	LPF2IN		Lowpass filter 2 buffer amplifier (class AB) input. Nominal voltage is 1.5 V.
21	CVREC		Compressor full-wave rectifier capacitor
22	CNF		Compressor negative feedback capacitor connection. Nominal voltage is 1.5 V.

Number	Name	Equivalent circuit	Description
23	PRENF		Compressor preamplifier negative feedback network connection. Nominal voltage is 1.5 V.
24	PREIN		Compressor preamplifier input. Nominal voltage is 1.5 V.

SPECIFICATIONS

Absolute Maximum Ratings

Parameter	Symbol	Rating	Unit
Supply voltage	V_{CC}	8	V
Power dissipation	P_D	300	mW
Operating temperature range	T_{opr}	-20 to 75	°C
Storage temperature range	T_{stg}	-40 to 125	°C

Recommended Operating Conditions

$T_a = 25\text{ °C}$

Parameter	Symbol	Rating	Unit
Supply voltage	V_{CC}	3	V
Supply voltage range	V_{CC}	2.4 to 6.0	V

Electrical Characteristics

Supply current

$V_{CC} = 3\text{ V}$, $T_a = 25\text{ °C}$, $V_{B1} = 1.2\text{ V}$, $f = 1\text{ kHz}$

Parameter	Symbol	Condition	Rating			Unit
			min	typ	max	
Quiescent supply current	I_{CC1}		2.5	3.4	5.0	mA
Standby supply current	I_{CC2}	No signal. CHGCTL is HIGH. STBY is LOW.	300	500	700	μA

Compressor

$V_{CC} = 3\text{ V}$, $T_a = 25\text{ °C}$, $V_{B1} = 1.2\text{ V}$, $f = 1\text{ kHz}$, $0\text{ dB} = 10\text{ mV}$, $A_{PV} = 20\text{ dB}$, $R_L = 10\text{ k}\Omega$

Parameter	Symbol	Condition	Rating			Unit
			min	typ	max	
Input impedance	R_i		-	50	-	kΩ
COU _T rms output voltage	V_o	$V_i = 0\text{ dB}$	210	265	335	mV
Gain error	A_{err}	$V_i = -20\text{ dB}$	-0.5	0.0	0.5	dB
		$V_i = -40\text{ dB}$	-1.0	0.0	1.0	
Total harmonic distortion	THD	$V_i = 0\text{ dB}$	-	0.25	1.00	%

LA8632, LA8632M

Parameter	Symbol	Condition	Rating			Unit
			min	typ	max	
COU _T rms output noise voltage	V _{NO}	R _g = 620 Ω, f = 20 Hz to 20 kHz	–	1.5	3.0	mV
Limiting voltage	V _L		1.25	1.40	1.55	V _{pp}
Maximum preamplifier voltage gain	A _{PV}		–	28	–	dB
Data voltage gain	A _{DV}		–2	0	2	dB
Mute attenuation	α	V _I = 0 dB, CMUTE is HIGH.	–60	–73	–	dB
Crosstalk	CT	Expander rms input voltage = 100 mV	–25	–34	–	dB

Expander

V_{CC} = 3 V, T_a = 25 °C, V_{BI} = 1.2 V, f = 1 kHz, 0 dB = 100 mV, LPF1 gain = 0 dB, R_L = 10 kΩ

Parameter	Symbol	Condition	Rating			Unit
			min	typ	max	
Expander rms output voltage	V _O	V _I = 0 dB	100	125	160	mV
Maximum expander rms output voltage	V _{O max}	THD = 10%, R _L = 10 kΩ	0.6	1.0	–	V
Gain error	A _{err}	V _I = 5 dB	–0.5	0	0.5	dB
		V _I = –20 dB	–1.0	0	1.0	
		V _I = –30 dB	–1.5	0	2.0	
Total harmonic distortion	THD	V _I = 0 dB, CHGCTL is HIGH.	–	0.40	1.00	%
Expander rms output noise voltage	V _{NO}	R _g = 620 Ω, f = 20 Hz to 20 kHz	–	13	80	μV
Mute attenuation	α	V _I = 0 dB, EMUTE is HIGH.	–60	–70	–	dB
Crosstalk	CT	Compressor rms input voltage = 10 mV	–60	–83	–	dB

Compressor lowpass filter

V_{CC} = 3 V, T_a = 25 °C, V_{BI} = 1.2 V, f = 1 kHz unless otherwise noted

Parameter	Symbol	Condition	Rating			Unit
			min	typ	max	
Attenuation	α	f = 3.4 kHz	–	–3	–	dB
		f > 3.4 kHz	–	–18	–	dB/octave
Total harmonic distortion	THD	V _{TXIN} = 10 mV	–	0.15	1.00	%
Maximum LPF2OUT rms output voltage	V _{O max}	THD = 10%, R _L = 10 kΩ	0.6	1.0	–	V

Expander lowpass filter

$V_{CC} = 3\text{ V}$, $T_a = 25\text{ }^\circ\text{C}$, $V_{BI} = 1.2\text{ V}$, $f = 1\text{ kHz}$ unless otherwise noted

Parameter	Symbol	Condition	Rating			Unit
			min	typ	max	
Attenuation	α	$f = 3.4\text{ kHz}$	-	-3	-	dB
		$f > 3.4\text{ kHz}$	-	-18	-	dB/octave
Total harmonic distortion	THD	$V_{LPF1IN} = 100\text{ mV}$	-	0.35	1.00	%
Maximum LPF1OUT rms output voltage	$V_o\text{ max}$	THD = 10%, $R_L = 7.7\text{ k}\Omega$	0.20	0.34	-	V

Frequency-shifted keyed comparator

$V_{CC} = 3\text{ V}$, $T_a = 25\text{ }^\circ\text{C}$, $V_{BI} = 1.2\text{ V}$, $f = 1\text{ kHz}$

Parameter	Symbol	Condition	Rating			Unit
			min	typ	max	
CHGCTL duty cycle	Duty	$V_{IN} = 100\text{ mV}$	43	48	53	%
CHGCTL ON voltage	V_{ON}		1	-	-	V
CHGCTL OFF voltage	V_{OFF}		-	-	0.4	V
CHGCTL input impedance	R_i		-	200	-	$\text{k}\Omega$
VHOLD input/output current	I_{IO}	$V_{CHGCTL} = 2\text{ V}$	-	80	-	μA
FSKOUT LOW-level output voltage	V_{OL}	$R_L = 100\text{ k}\Omega$	-	-	0.3	V
FSKOUT HIGH-level output voltage	V_{OH}	$R_L = 100\text{ k}\Omega$	2.8	-	-	V

Standby mode characteristics

$V_{CC} = 3\text{ V}$, $T_a = 25\text{ }^\circ\text{C}$, $V_{BI} = 1.2\text{ V}$, $f = 1\text{ kHz}$

Parameter	Symbol	Condition	Rating			Unit
			min	typ	max	
STBY voltage	V_{STBY}		-	-	0.7	V
STBY output current	I_o		-	-	50	μA

Digital input characteristics

$V_{CC} = 3\text{ V}$, $T_a = 25\text{ }^\circ\text{C}$, $V_{BI} = 1.2\text{ V}$, $f = 1\text{ kHz}$

Parameter	Symbol	Condition	Rating			Unit
			min	typ	max	
EMUTCTL and CMUTCTL LOW-level input voltage	V_{IL}		-	-	0.65	V
EMUTCTL and CMUTCTL HIGH-level input voltage	V_{IH}		$0.6V_{CC}$	-	-	V
EMUTCTL and CMUTCTL LOW-level input current	I_{IL}	$V_i = 0.2\text{ V}$	-	-	100	μA
EMUTCTL and CMUTCTL HIGH-level input current	I_{IH}	$V_i = 2\text{ V}$	-	-	5	μA

Typical Performance Characteristics

Power dissipation vs. ambient temperature

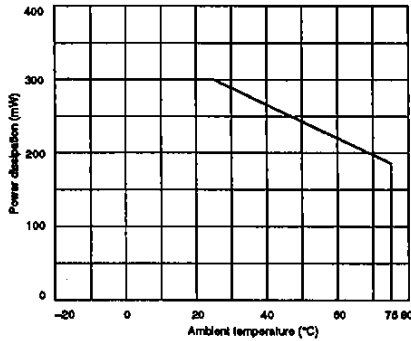

DESIGN NOTES

The gain of the compressor summing amplifier is two at DC, and undefined at AC. The cutoff frequency is determined by the RC network formed by the external capacitor connected to CNF and the internal 30 kΩ resistor.

The expander output is on TEOUT when INTCTL is HIGH or open, and on INTOUT when LOW.

In FSK waveform reconstruction, LOW-level output is during the positive signal interval of a cycle.

Compression

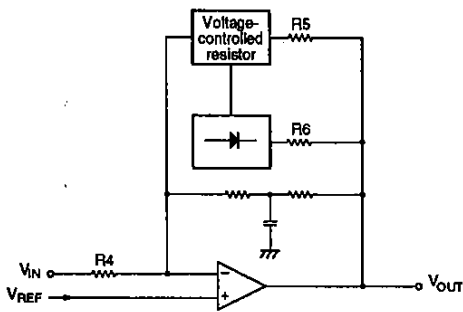

Figure 1. Compressor equivalent circuit

The compressor output voltage is given by the equation

$$V_O = \sqrt{\frac{R_5 R_6 I_2}{3 R_4}} V_{in} = 0.316 \times \sqrt{V_1}$$

where I_2 is half the common-mode current of the VCA voltage-to-current converter differential amplifier.

Expansion

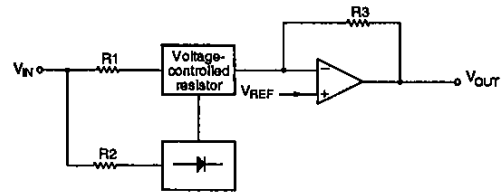

Figure 2. Expander equivalent circuit

The expander output voltage is given by the equation

$$V_O = \frac{3R_3}{R_1 R_2 I_1} V_I^2 = 10 \times V_I^2$$

where I_1 is half the common-mode current of the VCA voltage-to-current converter differential amplifier.

TYPICAL APPLICATION

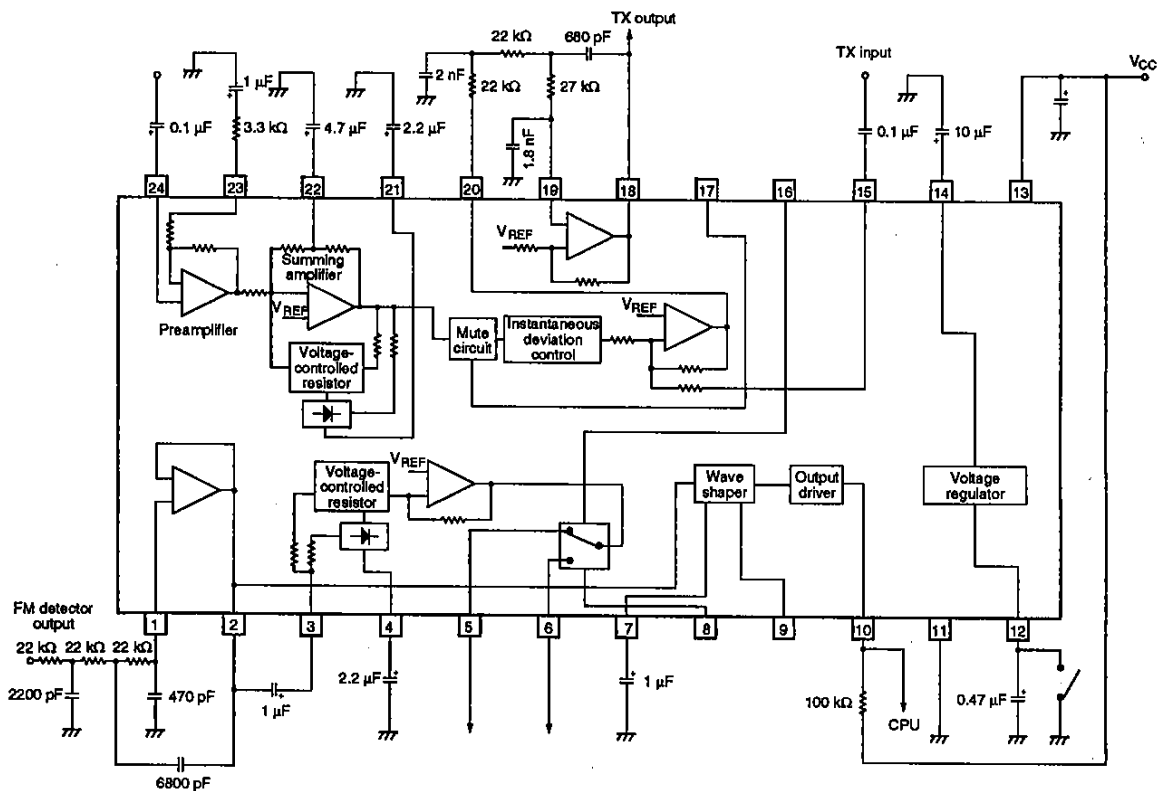

■ No products described or contained herein are intended for use in surgical implants, life-support systems, aerospace equipment, nuclear power control systems, vehicles, disaster/crime-prevention equipment and the like, the failure of which may directly or indirectly cause injury, death or property loss.

■ Anyone purchasing any products described or contained herein for an above-mentioned use shall:

- ① Accept full responsibility and indemnify and defend SANYO ELECTRIC CO., LTD., its affiliates, subsidiaries and distributors and all their officers and employees, jointly and severally, against any and all claims and litigation and all damages, cost and expenses associated with such use;
- ② Not impose any responsibility for any fault or negligence which may be cited in any such claim or litigation on SANYO ELECTRIC CO., LTD., its affiliates, subsidiaries and distributors or any of their officers and employees jointly or severally.

■ Information (including circuit diagrams and circuit parameters) herein is for example only; it is not guaranteed for volume production. SANYO believes information herein is accurate and reliable, but no guarantees are made or implied regarding its use or any infringements of intellectual property rights or other rights of third parties.