

SANYO	No.3045	LA7533
		IF Signal Processing (VIF + SIF) Circuit for TV / VCR Use

The LA7533 is an IC containing the VIF section and SIF section on a single chip in the DIP20S package. The use of the small-sized package serves to make VTR tuner units smaller.

As compared with the LA7530N, the LA7533 is improved in characteristics when it is operated at supply voltage 9V (DG, DP, RF AGC temperature characteristics).

The LA7533 is applicable to the circuit designed for the LA7530N.

Functions

- VIF section: VIF AMP, VIDEO DET, PEAK IF AGC, B/W NOISE CANCELLER, RF AGC, AFT, VIDEO MUTE.
- SIF section: SIF LIMITER AMP, FM DET, SND MUTE.

Features

- High-gain VIF amp requiring no preamp.
- Higher AGC speed.
- Adjustment-free FM detector because of ceramic discriminator-used quadrature detection.
- Possible to mute video, sound for VTR.
- Small-sized package.
- Minimum number of external parts required.
- Operated at supply voltage 9V

Maximum Ratings at Ta = 25°C

			unit
Maximum Supply Voltage	V _{CC} max	14	V
External Flow-out Current	I ₁₆ max	5	mA
Pin 20 Maximum Supply Voltage	V ₂₀ max	V _{CC}	V
Allowable Power Dissipation	P _d max	Ta ≤ 40°C	1.1 W
Operating Temperature	T _{opr}	-20 to +70	°C
Storage Temperature	T _{stg}	-55 to +125	°C

Operating Conditions at Ta = 25°C

			unit
Recommended Supply Voltage	V _{CC}	9	V
Operating Voltage Range	V _{CC op}	8.1 to 13.2	V

Package Dimensions

(unit : mm)

3021B

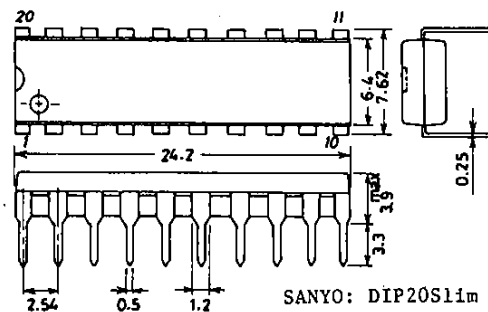

LA7533

Operating Characteristics at $T_a = 25^\circ\text{C}, V_{CC} = 9\text{V}, f_p = 58.75\text{MHz}, f_s = 54.25\text{MHz (VIF)}, f_o = 4.5\text{MHz (SIF)}$		min	typ	max	unit
Total Circuit Current	I_{17} DC	40	49	63	mA
Maximum RF AGC Voltage	V_{10H} DC	6.2	6.5	6.8	V
Minimum RF AGC Voltage	V_{10L} DC		0.1	0.5	V
Quiescent Video Output Voltage	V_{16} DC	4.2	4.6	5.0	V
Quiescent AFT Output Voltage	V_{11} DC	2.9	4.9	5.9	V
Input Sensitivity	V_i $f_m = 400\text{Hz}$ 40%AM, $V_o = 0.8\text{V}_{p-p}$	31	37	42	dB μ
AGC Range	GR $f_m = 400\text{Hz}$ 40%AM, $V_o = 0.8\text{V}_{p-p}$	57	63		dB
Maximum Allowable Input	$V_i \text{ max}$ $f_m = 15\text{kHz}$ 78%AM, $V_o = \pm 1\text{dB}$	90	130		mVrms
Video Output Amplitude	$V_o(\text{VIDEO})$ $V_i = 10\text{mVrms}$, $f_m = 15\text{kHz}$ 78%AM	1.4	1.65	1.9	V $_{p-p}$
Output S/N	S/N $V_i = 10\text{mVrms}$ CW	48	53		dB
Carrier Leak	CL $V_i = 100\text{mVrms}$, $f_m = 15\text{kHz}$ 78%AM	50	55		dB
Maximum AFT Voltage	V_{11H} $V_i = 10\text{mVrms}$ SWEEP	8.1	8.5	8.9	V
Minimum AFT Voltage	V_{11L} $V_i = 10\text{mVrms}$ SWEEP	0.1	0.4	0.9	V
AFT Detection Sensitivity	S_f $V_i = 10\text{mVrms}$ SWEEP	45	70	90	mV/kHz
White Noise Threshold Level	V_{WTH} $V_i = 10\text{mVrms}$ SWEEP	4.7	5.1	5.5	V
White Noise Clamp Level	V_{WCL} $V_i = 10\text{mVrms}$ SWEEP	2.9	3.3	3.7	V
Black Noise Threshold Level	V_{BTH} $V_i = 10\text{mVrms}$ SWEEP	1.6	1.85	2.1	V
Black Noise Clamp Level	V_{BCL} $V_i = 10\text{mVrms}$ SWEEP	2.6	2.9	3.2	V
SIF Output Signal Voltage	$V_o(\text{SIF})$ P/S=20dB	70	100	140	mVrms
Frequency Characteristic	f_c -3dB	5	7		MHz
Differential Gain	DG $V_i = -27\text{dBm}$ (peak) 87.5% VIDEOMOD		3		%
Differential Phase	DP $V_i = -27\text{dBm}$ (peak) 87.5% VIDEOMOD		3		deg
VIF Input Resistance	r_i		1.5		k Ω
VIF Input Capacitance	c_i		3.0		pF
SIF Limiting Voltage	$V_i(\text{lim})$ -3dB		300	600	μVrms
Detection Output Voltage	$V_o(\text{DET})$ $V_i = 100\text{mVrms}$, $f_m = 400\text{Hz}$, $\Delta f = \pm 25\text{kHz}$	440	670	800	mVrms
Total Harmonic Distortion	THD (DET) $V_i = 100\text{mVrms}$, $f_m = 400\text{Hz}$, $\Delta f = \pm 25\text{kHz}$		0.6	1.5	%
AM Rejection	AMR $V_i = 100\text{mVrms}$, $f_m = 400\text{Hz}$, $\Delta f = \pm 25\text{kHz}$ 30%AM	50	60		dB
Noise Output Voltage	V_N			3.5	mVrms
Pin 4 Muting Start Voltage	$V_{M(4)}$	0.3	0.5		V
Pin 20 Muting Attenuation	$ATT_{M(20)}$	60			dB

Equivalent Circuit Block Diagram

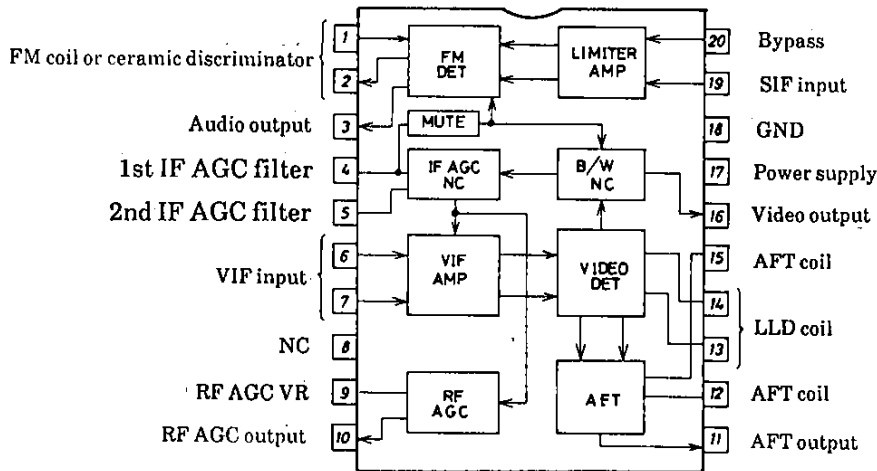

Sample Application Circuit (USA)

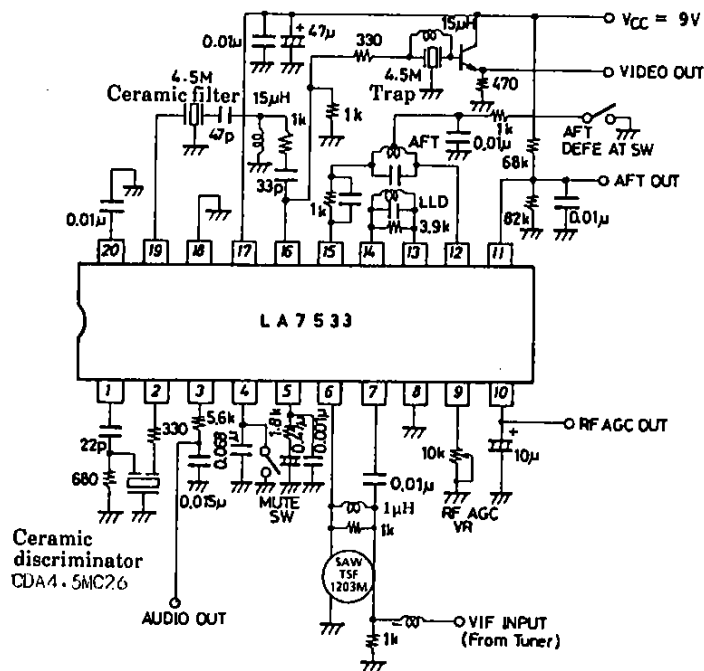

- No products described or contained herein are intended for use in surgical implants, life-support systems, aerospace equipment, nuclear power control systems, vehicles, disaster/crime-prevention equipment and the like, the failure of which may directly or indirectly cause injury, death or property loss.
- Anyone purchasing any products described or contained herein for an above-mentioned use shall:
 - ① Accept full responsibility and indemnify and defend SANYO ELECTRIC CO., LTD., its affiliates, subsidiaries and distributors and all their officers and employees, jointly and severally, against any and all claims and litigation and all damages, cost and expenses associated with such use:
 - ② Not impose any responsibility for any fault or negligence which may be cited in any such claim or litigation on SANYO ELECTRIC CO., LTD., its affiliates, subsidiaries and distributors or any of their officers and employees jointly or severally.
- Information (including circuit diagrams and circuit parameters) herein is for example only; it is not guaranteed for volume production. SANYO believes information herein is accurate and reliable, but no guarantees are made or implied regarding its use or any infringements of intellectual property rights or other rights of third parties.

This catalog provides information as of **June, 1996**. Specifications and information herein are subject to change without notice.