

SANYO

No.3293

LA7570TV, VTR IF Signal Processor
(Super Split PLL VIF+SIF)**Overview**

The LA7570 is a (VIF+SIF) circuit IC to support implementation of high picture quality and high sound quality.

The LA7570 uses not only full sync detection system but also split system which separates the video IF circuit and the sound IF circuit, improving sound quality and picture quality.

Functions**VIF Section**

- VIF amp
- RF AGC
- NSC amp
- AFT
- Sync detection
- VCO
- B/W NC
- Lock detection

1st SIF Section

- Pre amp
- 1st SIF detection

SIF Section

- SIF limiter amp
- FM quadrature detection

Muting

- Audio muting (pin 2)
- IS-15 switch (pin 11)
- Audio-Video muting (pin 4)

Features

- (1) Uses NSC technology-used super split system, improving buzz, beat characteristics.
- (2) Wide-band video characteristics obtainable because of the use of split system
- (3) Meets EIA IS-15 standard.
- (4) DIP-24 shrink package
- (5) Double time constant system supporting high-speed AGC

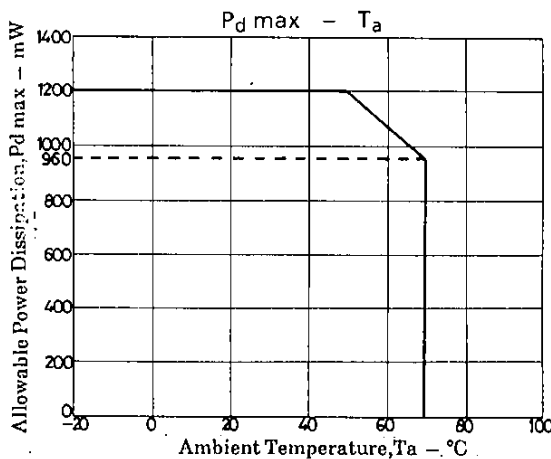
**Package Dimensions**

(unit: mm)

3067

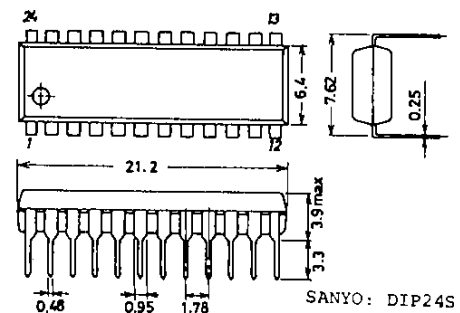

SANYO Electric Co., Ltd. Semiconductor Business Headquarters
TOKYO OFFICE Tokyo Bldg., 1-10, 1 Chome, Ueno, Taito-ku, TOKYO, 110 JAPAN

D079TA, TS · No.3293-1/11

Maximum Ratings at Ta = 25°C			unit	
Maximum Supply Voltage	V _{CC} max		13.8	V
Allowable Power Dissipation	P _d max	Ta ≤ 50°C	1200	mW
Operating Temperature	Topr		-20 to +70	°C
Storage Temperature	Tstg		-55 to +150	°C
Circuit Voltage	V ₃ , V ₁₁		V _{CC}	V
	V ₁₆		V _{CC}	V
	V ₂₃		V _{CC}	V
Circuit Current	I ₁		-1	mA
	I ₂₁		-5	mA
	I ₂₂		-2	mA
	I ₁₀		3	mA

Note) Assumes that the current flowing into the IC is positive (no sign) and current flowing out of the IC is negative.

Operating Conditions at Ta = 25°C			unit	
Recommended Supply Voltage	V _{CC}		9 or 12	V
Operating Voltage Range	V _{CC} op		8.2 to 13.2	V

Note) If it is necessary to connect wires direct to the IC externally, be sure to insert protection resistors (ex. pins 2, 14, 15)

Use a capacitor with good temperature characteristic for pin 11. (Example : OS capacitor, etc.)

Operating Characteristics at Ta = 25°C, V _{CC} = 9V				min	typ	max	unit
[VIF Section]							
Circuit Current	I ₉	V ₁₁ = 5V	38	48	64		mA
Quiescent Video Output Voltage	V ₂₁	V ₁₁ = 5V	4.6	4.95	5.3		V
Maximum RF AGC Voltage	V _{10H}	V ₁₁ = 8V	7.6	8.0	8.3		V
Minimum RF AGC Voltage	V _{10L}	V ₁₁ = 8V		0	0.5		V
Quiescent AFT Voltage	V ₁₆	V ₁₁ = 5V	2.8	4.4	5.8		V
Input Sensitivity	V _i		32	38	44		dB/μV
AGC Range	GR		55	61			dB
Maximum Allowable Input	V _i max		98	102			dB/μV
Video Output Amplitude	V _O (video)		1.55	1.85	2.15		Vp-p
Output S/N	S/N		48	52			dB
Sync Signal Tip Voltage	V ₂₁ (tip)	V _i = 10mV	2.6	2.85	3.1		V
920kHz Beat Level	I ₉₂₀	P = 0, C = -4dB, S = -14dB	40	50			dB
Frequency Characteristic	f _c	P = 0, S = -14dB,	5.0	6.5			MHz
Differential Gain	DG	f _p = 58.75MHz, V _i = 10mV, mod 87.5%, video signal		4	8		%
Differential Phase	DP	f _p = 58.75MHz, V _i = 10mV, mod 87.5%, video signal		3	8		deg
Maximum AFT Voltage	V _{16H}		8.0	8.6	8.9		V
Minimum AFT Voltage	V _{16L}		0.1	0.3	0.8		V
White Noise Threshold Voltage	V _{WTH}		5.5	5.85	6.2		V
White Noise Clamp Voltage	V _{WCL}		3.2	3.6	4.0		V
Black Noise Threshold Voltage	V _{BTH}		1.7	2.0	2.3		V
Black Noise Clamp Voltage	V _{BCL}		2.9	3.3	3.7		V
AFT Detection Sensitivity	S _f		30	45			65mV/kHz
VIF Input Resistance	R _i (VIF)	f = 58.75MHz	0.8	1.3	1.75		kΩ
VIF Input Capacitance	C _i (VIF)	f = 58.75MHz		3	6		pF

Continued on next page.

Continued from preceding page.

			min	typ	max	unit
APC Pull-in Range (U) 1	f_{PU-1}	$V_{20} = 3V$	0.45	0.8		MHz
APC Pull-in Range (L) 1	f_{PL-1}		-0.8	-0.45		MHz
APC Pull-in Range (U) 2	f_{PU-2}		1.0	1.7		MHz
APC Pull-in Range (L) 2	f_{PL-2}		-1.7	-1.0		MHz
VCO Maximum Variable Range	Δf_U	$V_{20} = 3V$	1.2	2.1		MHz
	Δf_L	$V_{20} = 7V$	-2.1	-1.2		MHz
VCO Control Sensitivity	β	$V_{20} = 5 \text{ to } 4.6V$	1.4	2.8	5.6	kHz/mV
[1st SIF Section]						
4.5MHz Conversion Gain	V_g		16	22	27	dB
1st SIF Input Resistance	R_i (SIF1)	$f = 54.25\text{MHz}$	1.2	2	2.7	k Ω
1st SIF Input Capacitance	C_i (SIF1)	$f = 54.25\text{MHz}$		3	6	pF
[SIF Section]						
SIF Limiting Sensitivity	V_i (lim)	$V_{11} = 5V$		43	49	dB/ μV
FM Detection Output Voltage	V_O	$V_{11} = 5V$	310	460	600	mVrms
AMR	AMR	$V_{11} = 5V$	40	55		dB
Distortion	THD	$V_{11} = 5V$		0.5	1	%
SIF S/N	S/N (SIF)	$V_{11} = 5V$	58	73		dB
[Muting and Defeat]						
AFT Defeat Start Voltage	V_{14TH}		0.5	1.2		V
AV Muting Start Voltage	V_{4TH}		0.5	1.1		V
FM Muting Start Voltage	V_{2TH}		0.9	1.9		V
AFT Defeat Voltage	VD_{16}		3.9	4.5	5.1	V

Equivalent Circuit Block Diagram

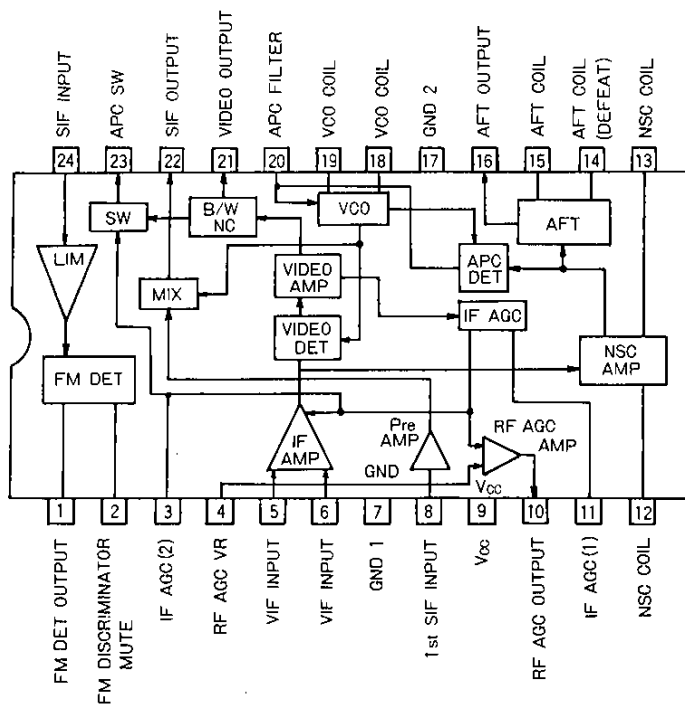

Precautions when using the LA7570

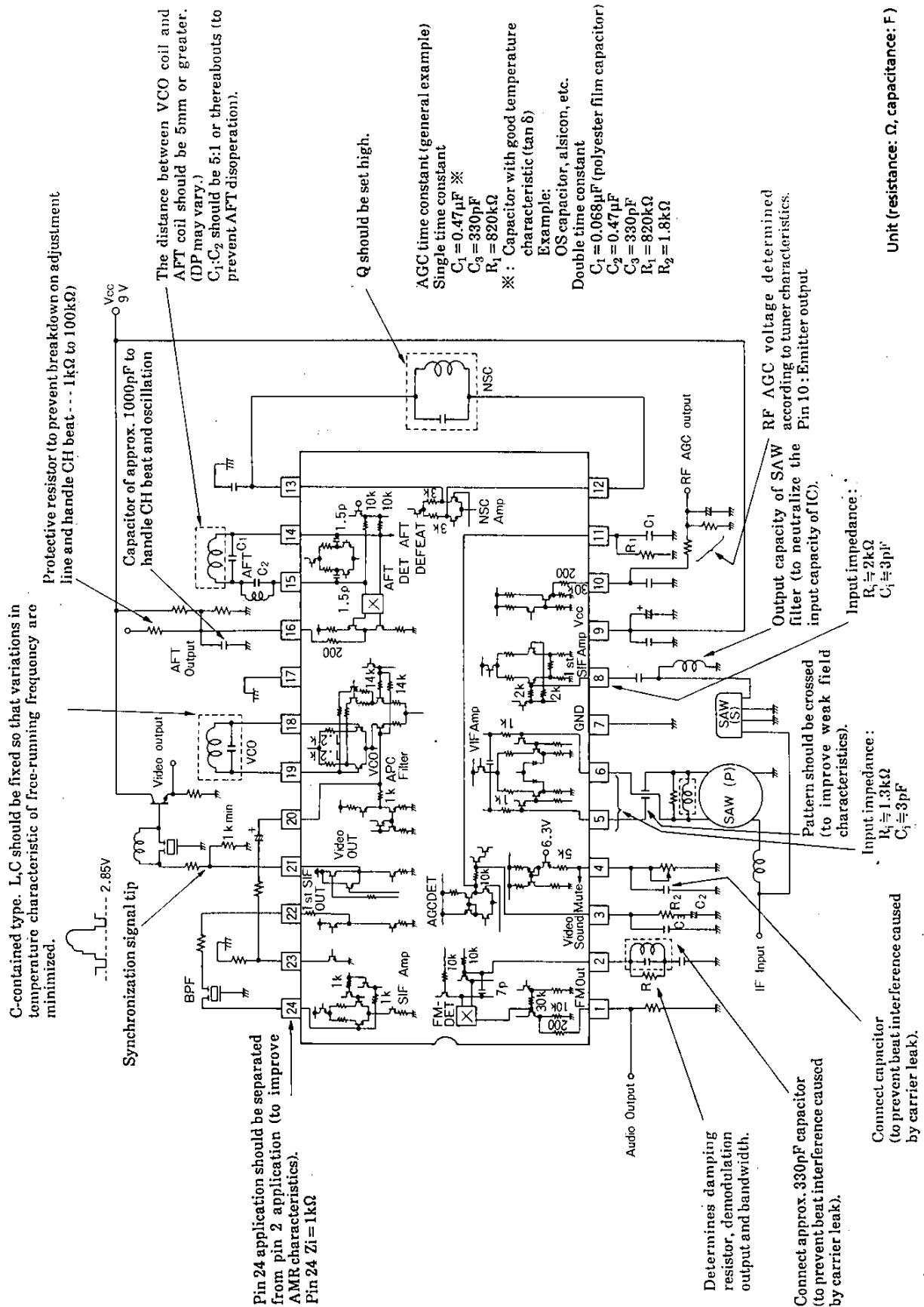

Description of Operation

1. IF amp

As shown in Fig.1, the IF amp consists of three amplifiers directly connected with balanced input. Amps 1, 2 and 3, and the gain are controlled by the AGC.

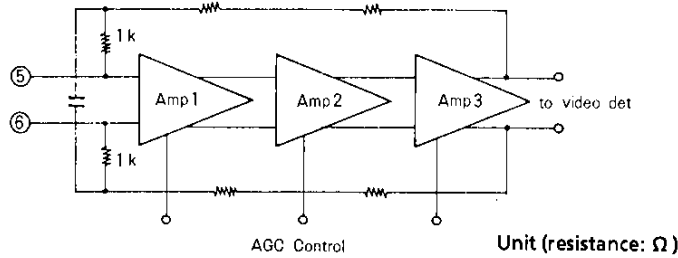

Fig. 1

2. Video detector

As shown in Fig.2-1, the video detector is a PLL-type. The bandwidth-compressed vestigial sideband system is used to transmit the TV signal. Therefore, the VIF signal selectivity characteristic of a receiver is such that the nyquist slope characteristic is provided near the picture carrier by a SAW filter.

When the IF signal passes through the nyquist slope, the sideband near the picture carrier is cut as shown in Fig.2-2, causing phase distortion to occur. This phase distortion causes nyquist buzz to occur.

This video detector has a Nyquist Slope Canceling (NSC) circuit connected to the PLL loop input to prevent the nyquist slope-caused phase distortion from occurring. This NSC circuit acts to compensate the phase distortion of the IF signal input to the APC detector and suppress the nyquist buzz.

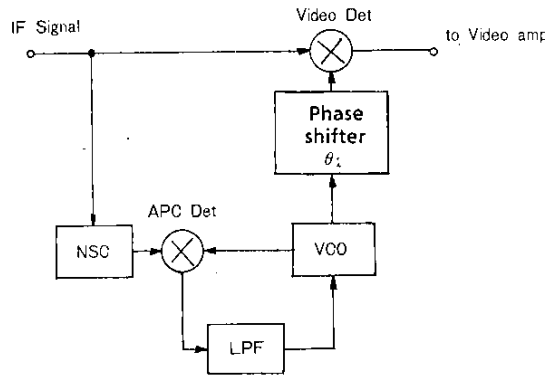

Fig. 2-1

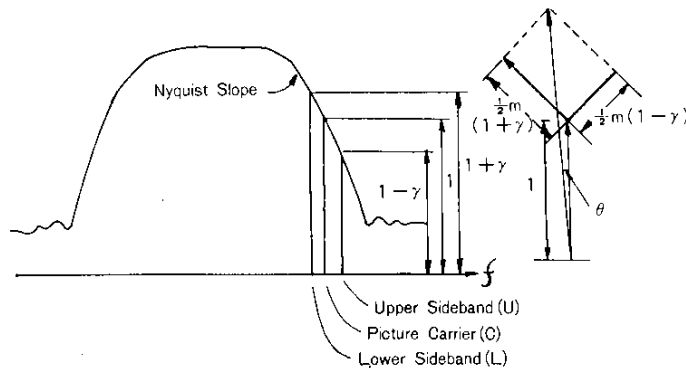

Fig.2-2 SAW Filter Characteristics

3. Video amp B/W noise canceler

As shown in Fig.3-1, the video amp amplifies the detection output voltage over a wide band to the desired voltage (= 1.85Vp-p). The amplified video signal passes through the B/W noise canceler and is output to pin 21.

White: The noise canceler operates as shown in Fig.3-3 as the input of noise exceeding the white level of the video signal as shown in Fig.3-2 will cause noticeable noise on the screen.

Black: The noise canceler operates as shown in Fig.3-3 as the input of noise exceeding the sync signal tip as shown in Fig.3-2 will prevent proper operation of the next-stage sync separation circuit.

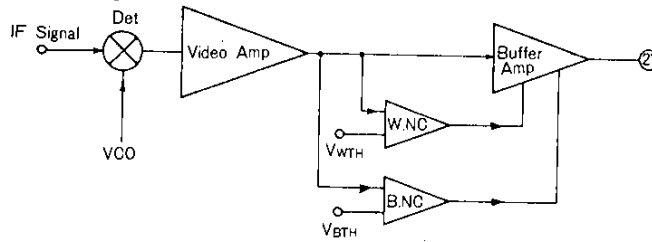

Fig.3-1

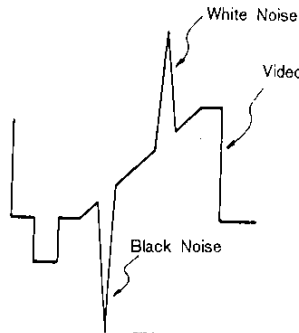

Fig.3-2

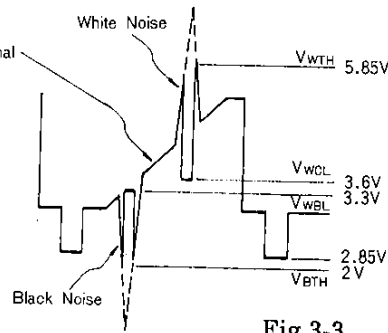

Fig.3-3

4. Lock detector

As shown in Fig.4, the lock detector is an APC time constant switching detection circuit which expands the APC pull-in range. The detection circuit operates by the OR of the IF AGC voltage and the video signal. The weak field is detected by the IF AGC voltage and the unlock state when detuned is detected from the video signal.

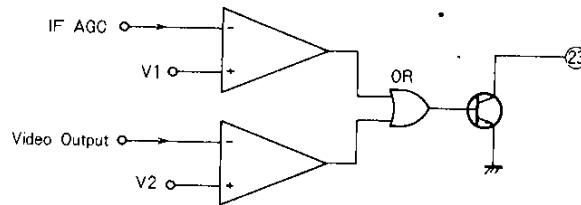

Fig.4

5. AGC detector

As shown in Fig.5, the AGC detector is equipped with a noise canceler function which prevents malfunction of the AGC system. The AGC detection output (pin 11) is also used for video output, FM detection output, and as the simultaneous mute (AV MUTE) pin.

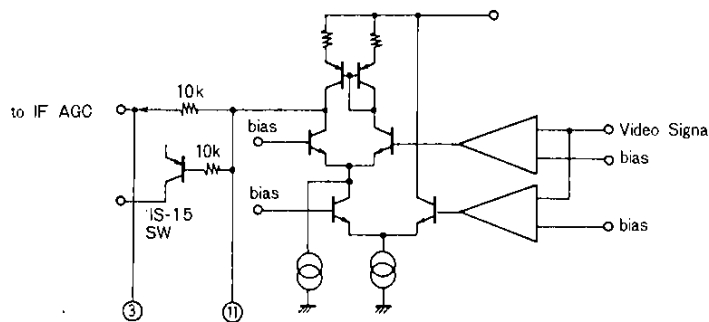

Fig.5

Unit (resistance: Ω)

6. RF AGC

As shown in Fig.6-1, the RF AGC controls the gain of the tuner's RF amp. Measurement is made whether the region is snow region (noise on the screen, poor S/N ratio) or a saturation region (contours can be clearly seen but look bad due to video signal distortion), and the RF AGC delay point is set as shown in Fig.6-2. Pin 4 is also used for video output, FM detection output, and as the simultaneous mute (AV MUTE) pin.

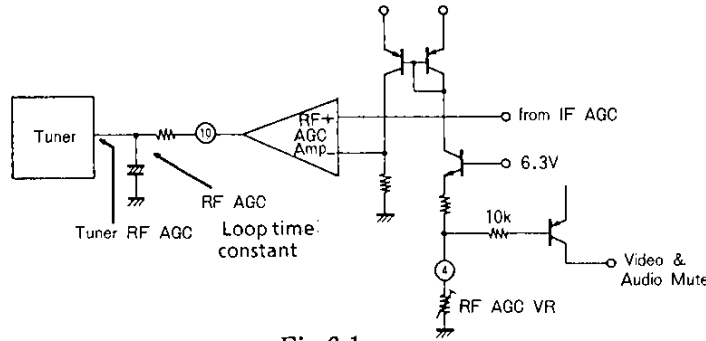

Fig.6-1

Unit (resistance: Ω)

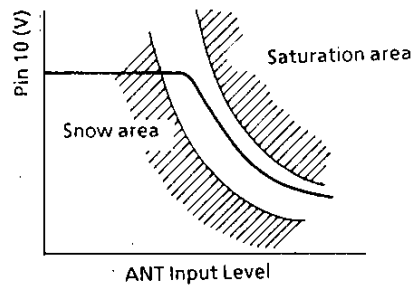

Fig.6-2

7. AFT

As shown in Fig.7, the AFT is a balanced-type using a quadrature detection circuit. The input signal is shifted 90° by the internal capacitor and external phase shifter, and quadrature-detected. Pin 14 is also used as the AFT Defeat pin.

C₂ forms a sound carrier trap for preventing malfunction of the AFT.

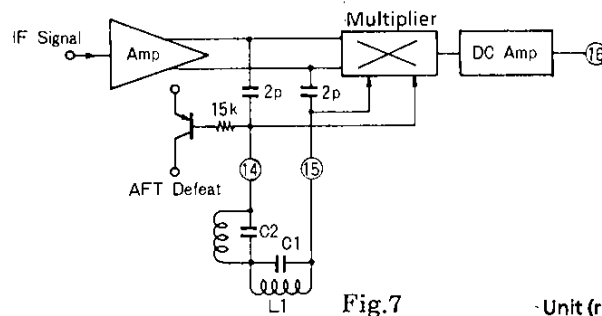

Fig.7

Unit (resistance: Ω , capacitance: F)

8. SIF limiting amp

As shown in Fig.8, the SIF limiting amp is an unbalanced limiting amp consisting of four stages directly connected. There is negative feedback within the IC to balance the differential amplifier.

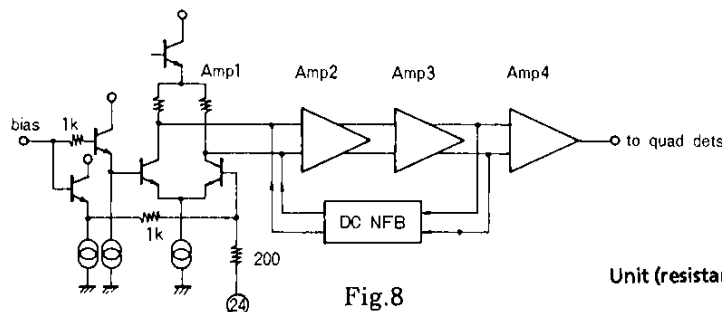

Fig.8

Unit (resistance: Ω)

9. Quadrature detection

SIF quadrature detection is by the single pin detector with internal phase shift capacitor, shown in Fig.9. FM detection is by shifting the SIF signal 90° and multiplying it. The characteristics of the phase shifting circuit are as follows:

1. Demodulation output mainly Q_L ,
2. Distortion linearity of phase shifting circuit, symmetry of S curve

The linearity of the phase shifting circuit can be improved by lowering Q_L and increasing the band with a single-tuned circuit, but the FM detection output will drop.

Pin 2 is also used as the SIF mute pin.

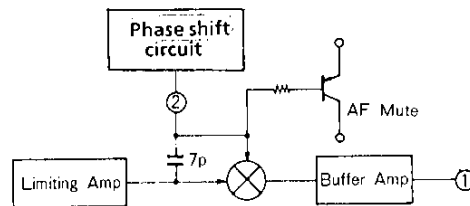

Fig.9

Unit (resistance: Ω , capacitance: F)

10. 1st SIF detector

The 1st SIF detector is configured as shown in Fig.10. A preamplifier is placed in the preceding stage of the detector.

This detector is used to process the 1st SIF signal only. Therefore, the detector is not affected by nonlinearity of the VIF amplifier, etc., improving the buzz, beat characteristics.

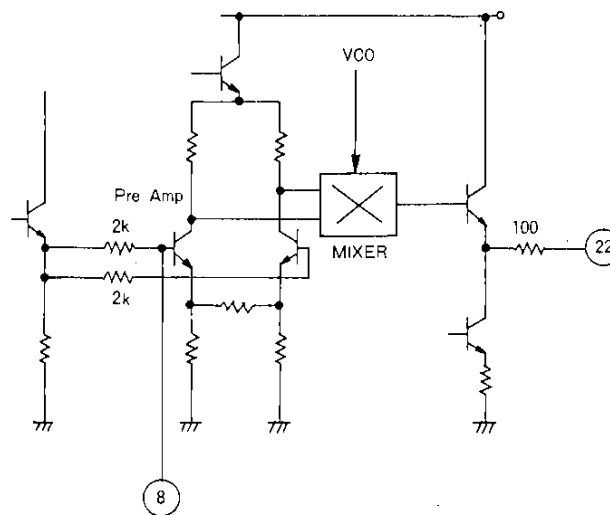

Fig.10

Unit (resistance: Ω)

VCO adjustment methods

The following two methods are available for adjusting the VCO.

1. APC voltage offset adjustment method
 - a. Connect a digital voltmeter to pin 20 (APC filter pin) (Fig.1).
 - b. Lower the IF input level and connect the IF AGC (pin 11) to GND. Measure the voltage on pin 20 (V_1) at this time.
 - c. Raise the IF input level to the desired value. Free the IF AGC from GND (internal AGC). Adjust the VCO so that the voltage (V_2) on pin 20 is equal to V_1 .

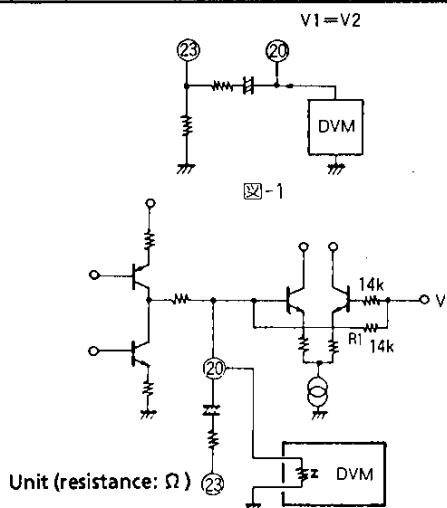

Note: When adjusting by this method, use a DVM (digital voltmeter) with high input impedance. At $Z_i = 10M\Omega$, the adjustment error is approximately 20kHz. The error (ΔV) with the DVM connected is

$$\Delta V(mV) = V \left(1 - \frac{R_1}{Z + R} \right)$$

The change in VCO free-running frequency (Δf) according to ΔV is $\Delta f(kHz) = \Delta V \times \beta$, where $\beta =$ VCO control sensitivity (kHz/mV)

2. Direct reading method

- a. Lower the IF input level and adjust the IF AGC (pin 11) to between GND and about 4V (VCO free run).
- b. Monitor the carrier frequency leaking from pins other than the VCO coil, or pattern, chassis, and adjust the VCO coil to obtain the desired frequency (fp).

Measurement of VIF selectivity characteristics

The pull-in range of the PLL-type VIF IC is approximately $\pm 2MHz$. Thus, it is not possible to measure the matching characteristics of the tuner SAW filter easily as with the dummy synchronization detection method. The following is just one example of how to measure the selectivity characteristics for a single signal.

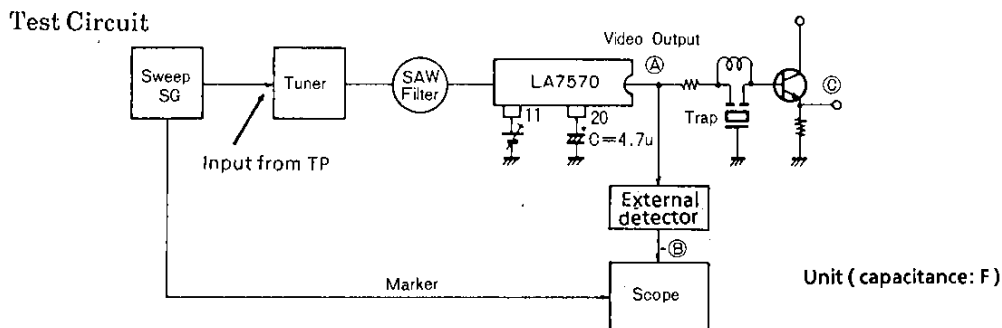

Conditions

1. Apply voltage to the IF AGC (pin 11) and adjust unit the video output (A) is 0.5Vp-p.
2. Attach a 4.7 μF capacitor to the APC filter (pin 20) so that the PLL is unlocked.
3. The waveform shown in the diagram below can be monitored through the externally mounted detector.

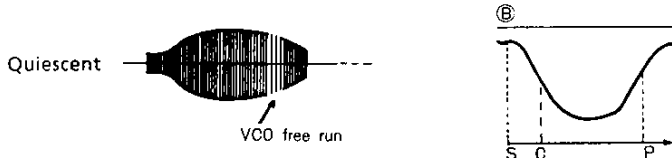

Note: Error will occur in the measurement of the selectivity characteristics if the video frequency changes between (A) and (C) (by a video equalizer, etc.).

Externally Mounted Detector (Example)

Unit (resistance: Ω , capacitance: F)

(1)

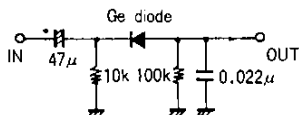

(2) Voltage doubler type

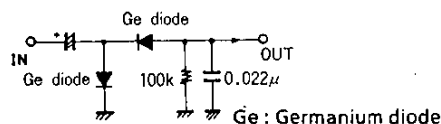

LA7570

Coil Specification

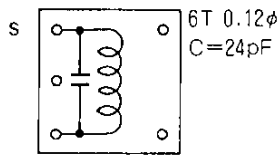
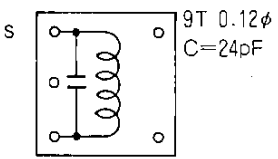
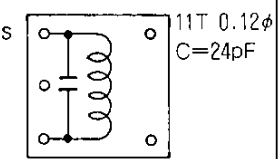
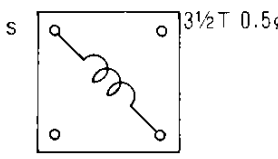
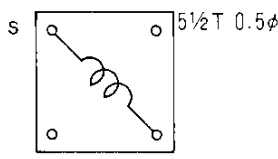
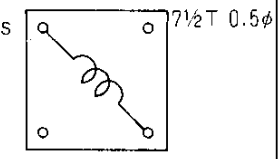
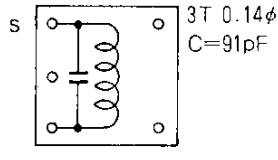
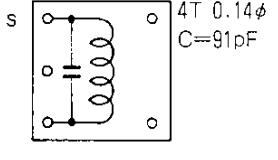
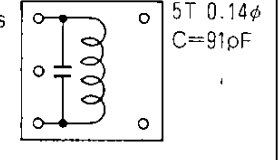
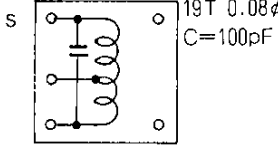
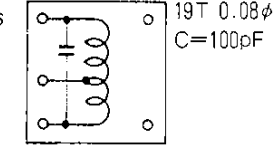
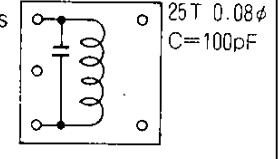
	JAPAN f=58.75MHz	US f=45.75MHz	PAL f=38.9MHz
VCO coil T ₁	 <p>6T 0.12φ C=24pF</p>	 <p>9T 0.12φ C=24pF</p>	 <p>11T 0.12φ C=24pF</p>
	HW6226-4	HW6227-4	MA6389
AFT coil T ₂	 <p>3½T 0.5φ</p>	 <p>5½T 0.5φ</p>	 <p>7½T 0.5φ</p>
	MA8181	MA6343	MA7115
NSC coil T ₃	 <p>3T 0.14φ C=91pF</p>	 <p>4T 0.14φ C=91pF</p>	 <p>5T 0.14φ C=91pF</p>
	MA8159-2	KW828J	KW9001
SIF coil T ₄	 <p>19T 0.08φ C=100pF</p>	 <p>19T 0.08φ C=100pF</p>	 <p>25T 0.08φ C=100pF</p>
	KS6102-1	KS6102-1	MA8182
SAW Filter (SANYO)	Picture TSF1132L Sound TSB1101P	Picture TSF1229L Sound TSB1205P	Picture TSF5315

