

SANYO

No. 5110

LA7425**NTSC Format Single-Chip Signal Processing IC
for VHS VCR Products****Overview**

The LA7425 is a single-chip video signal processing IC for use in VHS format VCR products. The number of required adjustments has been reduced to a single adjustment by IC chip internal trimming. The incorporation of a playback equalizer and other circuits on chip provides a significant reduction in external components and thus significantly reduces the cost of manufacturing the signal processing printed circuit board. This product can also support simplified S-VHS playback, which is becoming a standard feature in VCR products in the Japanese market.

Features

- Only one adjustment point (comb filter phase adjustment)
(The AGC, carrier, deviation and PB-Y level are adjustment free.)
(If an LA7411/16 is used as the head amplifier, the Y/C record current will also be adjustment free.)
- Simplified S-VHS playback support
 - Built-in S-VHS discrimination circuit
 - Built-in equalizer switch
 - Automatic demodulator gain switching
 - Internal automatic de-emphasis characteristics switching
- Only a minimal number of external components required (85 components: This corresponds to a 38% reduction over previous Sanyo products ... CNR and SQPB not handled, and REC EQ not included.)
Components newly incorporated on chip:
 - Playback equalizer (include chroma trap), limiter balance filter, capacitor and resistor for detail enhancer, record chroma 7.8 MHz trap, playback chroma LPF, ACC filter
- High performance/multifunctionality
Linear phase type picture controller
Double high-pass noise canceller, high-speed AFC, DCC
New built-in functions
 - FM AGC, synchronization detection circuit, linear control circuit for high-pass noise canceller,

playback mode Y/C separator output, chroma noise canceller

- Single CCD system

The LA7425 supports the following functions with the addition of only a single CCD (1H delay) device: comb filter, YNR, DOC and chroma crosstalk cancellation. Thus the cost of external components is lowered.

- Full HQ support (YNR, CNR, detail enhancer and WCL up)

Package Dimensions

unit: mm

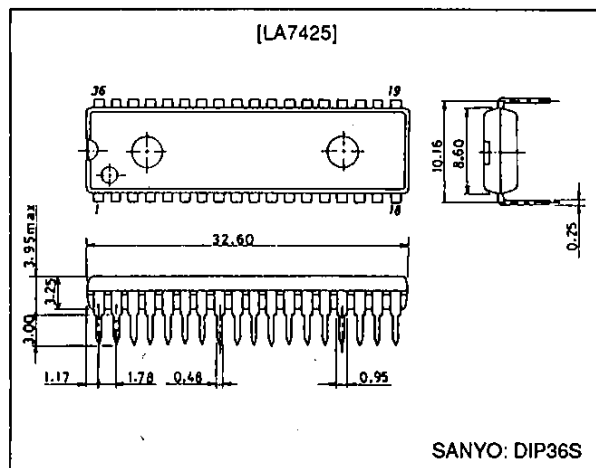
3170-DIP36S**SANYO Electric Co., Ltd. Semiconductor Business Headquarters**

TOKYO OFFICE Tokyo Bldg., 1-10, 1 Chome, Ueno, Taito-ku, TOKYO, 110 JAPAN

51595TH (OT) No. 5110-1/7

Functions

All VHS format VCR (NTSC) signal processing functions

	Luminance		Chrominance	
R/P	Video amp. Feedback clamp Main LPF YNR VCA Sync separator 4.1 V regulator		3.58 BPF ACC amp. ACC det. Main converter 1.3 M LPF VXO/XO Side lock det. 3rd lock protector	Half H killer BGP generator Killer det. VCO Phase shifter Sub converter 4.21 BPF
REC	Video AGC amp. Video AGC det. Pre LPF Y/C comb filter Detail enhancer 1/2 f_H carrier shift	NL emphasis Main emphasis White/dark clip FM modulator Sync det.	Pre amp. Burst emphasis Killer APC det. AFC det. Burst gate amp.	
PB	FM equalizer 629 chroma trap FM AGC amp. FM AGC det. S-VHS det. Double limiter FM demodulator Double high-pass noise canceller	QV/QH/character insert Sub LPF Main de-emphasis DOC Drop out det. NL de-emphasis Picture control Y/C mix	Pre amp. Burst de-emphasis PB amp. Killer CNR Carrier balancer Burst gate amp. Chroma noise canceller	APC det. ID det. DCC Trick det. DPLL

Specifications

Maximum Ratings at $T_a = 25^\circ\text{C}$

Parameter	Symbol	Conditions	Ratings	Unit
Maximum supply voltage	$V_{CC \text{ max}}$		7.0	V
Allowable power dissipation	$P_d \text{ max}$	$T_a \leq 65^\circ\text{C}$	1070	mW
Operating temperature	T_{opr}		-10 to +65	$^\circ\text{C}$
Storage temperature	T_{stg}		-40 to +150	$^\circ\text{C}$

Operating Conditions at $T_a = 25^\circ\text{C}$

Parameter	Symbol	Conditions	Ratings	Unit
Recommended supply voltage	V_{CC}		5.0	V
Operating supply voltage range	$V_{CC \text{ op}}$		4.8 to 5.5	V

Operating Characteristics at $T_a = 25^\circ\text{C}$, $V_{CC} = 5.0 \text{ V}$

Parameter	Symbol	Conditions	min	typ	max	Unit
[Record Mode Y System]						
Record mode current drain	I_{CCR}	Input: 1.0 Vp-p video signal	95	120	145	mA
EE output level	V_{EE}	The T28 output level	2.04	2.15	2.26	Vp-p
AGC characteristics 1	AGC1	With the input level increased 6 dB	0	0.5	1.0	dB
AGC characteristics 2	AGC2	With the input level decreased 6 dB	-1.0	-0.3	0	dB
AGC characteristics 3	AGC3	Input: with only the sync level increased 6 dB, measure the T28 sync level.	540	600	660	mVp-p
AGC characteristics 4	AGC4	Input: with only the sync level decreased 6 dB, measure the T28 sync level.	370	410	450	mVp-p
Sync separator output level	V_{SYR}	The T26 output pulse peak value	4.0	4.4	4.6	Vp-p
Sync separator output pulse width	PW_{SYR}	The T26 output pulse width	4.1	4.4	4.7	μs
Sync separator output leading edge delay time	ΔT_{SYR}		0.8	1.0	1.2	μs
Sync separator threshold level	TH_{SYR}			-23	-19	dB
VCA detection voltage	V_{VCA}		3.00	3.20	3.40	V

Continued on next page.

Continued from preceding page.

Parameter	Symbol	Conditions	min	typ	max	Unit
Y comb characteristics	G _{Y-COMB}	Input: chroma noise test signal 1 Vp-p, measure T2.			-25	dB
C comb characteristics	G _{C-COMB}	Input: white 50% plus CW 3 MHz, measure T21.			-25	dB
Record YNR operation EP/LP	R-YNR		10	12	14	mV
CCD front-end LPF frequency characteristics 1	PFIL1	The attenuation at 4 MHz referenced to 500 kHz	0	0.5	1.0	dB
CCD front-end LPF frequency characteristics 2	PFIL2	The attenuation at 10 MHz referenced to 500 kHz	-17	-15	-13	dB
Y LPF frequency characteristics 1	YLPF1	The attenuation at 1 MHz referenced to 500 kHz	-0.5	0	+0.5	dB
Y LPF frequency characteristics 2	YLPF2	The attenuation at 2 MHz referenced to 500 kHz	-0.5	+0.5	+1.5	dB
Y LPF frequency characteristics 3	YLPF3	The attenuation at 3 MHz referenced to 500 kHz	-8	-6	-4	dB
Y LPF frequency characteristics 4	YLPF4	The attenuation at 3.58 MHz referenced to 500 kHz			-15	dB
Y LPF frequency characteristics 5	YLPF5	The attenuation at 4.2 MHz referenced to 500 kHz			-15	dB
FM modulator output level	V _{FM}	With no input signal	0.96	1.08	1.21	mVp-p
FM modulator output second harmonic distortion	H _{MOD}			-40	-35	dB
Carrier frequency	F _{FM}		3.30	3.40	3.50	MHz
Deviation	FM _{DEV}		0.95	1.00	1.05	MHz
FM modulator linearity	L _{MOD}	T3 = 2.6 V, 2.85 V, 3.1 V	-2	0	+2	%
1/2 f _H carrier shift	CS		6.8	7.8	9.5	kHz
Emphasis gain	G _{EMPH}	Input: 0.5 Vp-p 10 kHz sine wave	-0.5	0	+0.5	dB
Detail enhancer characteristics 1	G _{ENH1}	Input: -10 dB, 2 MHz	1.6	1.9	2.6	dB
Detail enhancer characteristics 2	G _{ENH2}	Input: -20 dB, 2 MHz	3.1	4.1	5.1	dB
Detail enhancer characteristics 3	G _{ENH3}	Input: -30 dB, 2 MHz	5.3	6.3	7.3	dB
Detail enhancer characteristics 4	G _{ENH4}	Input: -30 dB, 2 MHz, edit mode	2.9	3.9	4.9	dB
NL emphasis characteristics 1	G _{NLEMP1}	Input: 500 mVp-p, 2 MHz	0.5	1.4	2.3	dB
NL emphasis characteristics 2	G _{NLEMP2}	Input: -10 dB, 2 MHz	2.6	3.8	5.2	dB
NL emphasis characteristics 3	G _{NLEMP3}	Input: -20 dB, 2 MHz	4.9	6.4	7.9	dB
Main emphasis characteristics 1	G _{ME1}	Input: -20 dB, 200 kHz	4.9	5.2	5.5	dB
Main emphasis characteristics 2	G _{ME2}	Input: -20 dB, 2 MHz	13.1	13.6	14.1	dB
White clipping level	L _{WC}	Input: 1.0 Vp-p white 100% video signal	180	190	200	%
Dark clipping level	L _{DC}	Input: 1.0 Vp-p white 100% video signal	-55	-50	-45	%
Synchronization detector output level	V _{SYDET}		2.7	3.0	3.3	V
[Playback Mode Y System]						
Playback mode current drain	I _{CCP}		120	150	180	mA
FM equalizer characteristics 1	G _{FM-EQ1}	Input: 300 mVp-p, 4 MHz	-1.0	+1.0	+3.0	dB
FM equalizer characteristics 2	G _{FM-EQ2}	Input: 300 mVp-p, 629 kHz			-30	dB
Dropout compensation period	T _{DOC}		8	10	12	H
DOC loop gain	G _{DOC}	5H later	-1.0	0	+1.0	dB
Playback Y level	V _{Y-OUT}		2.04	2.15	2.26	Vp-p
FM demodulator linearity	L _{DEM}	2, 4, 6 MHz	-3.5	0	+3.5	%
Demodulator carrier leakage	CL	Input: 4 MHz, 300 mVp-p		-40	-35	dB
Playback YNR characteristics 1 (LP/EP)	P-YNR1	Input: white 50% plus CW	-9	-8	-7	dB
Playback YNR characteristics 2 (SP)	P-YNR2	Input: white 50% plus CW	-4.5	-3.5	-2.5	dB
NL de-emphasis characteristics 1	G _{NLDEEM1}	Input: -10 dB, 2 MHz	-6.0	-5.0	-4.0	dB
NL de-emphasis characteristics 2	G _{NLDEEM2}	Input: -20 dB, 2 MHz	-9.0	-8.0	-7.0	dB
Noise canceller characteristics 1	G _{WNC1}	Input: -10 dB, 1.2 MHz	-2.7	-2.2	-1.7	dB
Noise canceller characteristics 2	G _{WNC2}	Input: -20 dB, 1.2 MHz	-7	-6	-5	dB
Noise canceller characteristics 3	G _{WNC3}	Input: -30 dB, 1.2 MHz	-13	-11	-9	dB

Continued on next page.

Continued from preceding page.

Parameter	Symbol	Conditions	min	typ	max	Unit
Picture control hard response characteristics 1	G _{PH1}	Input: -10 dB, 1 MHz	1.0	1.5	2.0	dB
Picture control hard response characteristics 2	G _{PH2}	Input: -10 dB, 2 MHz	3.2	4.2	5.2	dB
Picture control soft response characteristics 1	G _{PS1}	Input: -10 dB, 1 MHz	-6.0	-5.0	-4.0	dB
Picture control soft response characteristics 2	G _{PS2}	Input: -10 dB, 2 MHz	-12.0	-10.0	-8.0	dB
Quasi-V insertion level (playback)	ΔV_{DP}	V ₂₉ = 5 V	-80	0	+80	mV
Quasi-H insertion level (playback)	ΔH_{DP}	V ₂₉ = 2.5 V	-200	-100	0	mV
Sync separator output level	V _{SYN}	Pin 26 output pulse peak value	4.0	4.4	4.6	V _{p-p}
Sync separator output pulse width	PW _{SYN}	Pin 26 output pulse width	4.3	4.6	4.9	μ s
Sync separator output leading edge delay time	ΔT_{SYN}		1.25	1.45	1.65	μ s
Built-in regulator voltage	V _{REG}		3.9	4.1	4.3	V
S-VHS discriminator output level	V _{SVHSP}		2.7	3.0	3.3	V
[Record Mode Chroma System]						
Y/C separator output burst level	V _{OR-21}	Pin 21 burst level	120	150	180	mV _{p-p}
Chroma low frequency conversion burst level	V _{OR-14}	Input: standard color bar signal 1 V _{p-p}	322	380	438	mV _{p-p}
Burst emphasis	G _{BE}		5.5	6.0	6.5	dB
VXO oscillator level	V _{VXO-R}	Input: standard color bar signal 1 V _{p-p}	400	500	600	dB
ACC characteristics 1	ACC _{R1}	With only the color signal level increased 6 dB		+0.2	+0.5	dB
ACC characteristics 2	ACC _{R2}	With only the color signal level decreased 6 dB	-0.5	-0.1		dB
ACC killer on input level	V _{IN-ACCK-ON}		-29	-26	-23	dB
ACC killer on output level	V _{O-ACCK}			-60	-50	dB
ACC killer recovery input level	V _{IN-ACCK-OFF}		-23	-20	-17	dB
APC pull-in range 1	Δf_{APC1}		+350	+480		Hz
APC pull-in range 2	Δf_{APC2}			-770	-350	Hz
AFC pull-in range 1	Δf_{AFC1}		+1.0	+3.0		kHz
AFC pull-in range 2	Δf_{AFC2}			-2.5	-1.0	kHz
Record Y/C level ratio	C/FM		-9.9	-9.1	-8.3	dB
[Playback Mode Chroma System]						
Video output burst level	V _{OP-28}	SP mode, input burst 160 mV _{p-p}	235	277	319	mV _{p-p}
Pin 21 output burst level	V _{OP-21}	SP mode, input burst 160 mV _{p-p}	149	175	201	mV _{p-p}
ACC characteristics 1	ACC _{P1}	With the input chroma level increased 6 dB		0.5	0.8	dB
ACC characteristics 2	ACC _{P2}	With the input chroma level decreased 6 dB	-0.5	-0.2		dB
Killer on input level	V _{ACK-P}		-55		-40	dB
Killer on chroma output level	V _{OACKP}			-44	-40	dB
Main converter carrier leakage	C _{LP}	The 4.21 MHz carrier leakage component		-40	-33	dB
4.84 MHz spurious signal level	SPR ₄₈₄				-35	dB
Burst de-emphasis	G _{BD}		-5.35	-5.10	-4.85	dB
XO output level	V _{XO-P}		370	470	570	mV _{p-p}
XO oscillator frequency deviation	Δf_{XO}	$\Delta f_{XO} = f - 3579545$ (Hz)	-7	0	+7	Hz

Control Pin Function Table

Pin No.	Control function	L	M	H	
1	CNR adjustment Forced NVHS control	REC	Synchronization detector output when open. (0 V when synchronized, 3.0 V when not synchronized)		3.6 V or higher CNR adjustment mode
		PB	S-VHS detector output when open. (0 V in normal mode, 3.0 V for S-VHS)		3.6 V or higher Forced N-VHS mode
4	Record/playback switching	Open Record mode			3.8 V or higher Playback mode
7	SP/LP/EP switching	1.2 V or lower SP mode	1.8 to 2.7 V LP mode	3.3 V or higher EP mode	
11		If a 3.3 kΩ resistor is connected between pin 11 and ground, the playback mode SP YNR will be set to strong (K = 0.5), and to very strong (K = 0.6) in LP/EP modes.			
12	Edit/picture control	2 to 2.5 V Picture control: soft	2.5 to 3 V Picture control: hard	3.6 V or higher Edit mode	
13	Noise canceller control Y/C mix off	1.5 V or lower Noise canceller: off	2.0 to 3.0 V Noise canceller linear control	3.8 V or higher Y/C mix: off (playback Y/C separate output)	
16	APC loop switching (trick mode)				3.8 V or higher (200 μA or higher) APC loop "post-comb"
21					3.5 V or higher Record: XO: forced free-run
23	CNR control	1.5 V or lower ***	Open CNR: on	2.5 V or higher CNR: off	
29	QV/QH insertion	0.8 V or lower Through	1.0 to 2.2 V Character insertion	2.5 to 3.2 V QH insertion	3.8 V or higher QV insertion
30	Rotary pulse input	1.2 V or lower Low CH	1.8 V or higher High CH		
34	DOC stop control	Open Normal mode	3.75 V or higher DOC stopped		

Note: Do not set pin 12 to a voltage of 1.5 V or lower, since the chip will enter test mode.

Mode Control Table

		SP		EP		LP		
		Normal	Edit	Normal	Edit	Normal	Edit	
REC	Detail enhancer	Strong	Weak	Weak	Weak	Weak	Weak	
	YNR	K	—		0.65			
		LIMITT	—		5 IRE			
	Y/C comb separator	C	○	—	○	—	○	—
		Y			○			
	1/2 f _H carrier shift	—				○		
	Nonlinear emphasis	—				○		
Burst emphasis			○			—		
PB	YNR	K	0.2	0.5	0.2	0.5	0.2	
		LIMITT	5 IRE	11 IRE	5 IRE	11 IRE	5 IRE	
	Picture control	○	Center point	○	Center point	○	Center point	
	Burst de-emphasis			○			—	
	Crosstalk cancellation correlation switching	○				—		
	APC loop	Pre-comb*				Post-comb		
Four phase shift clock	DPLL output				HHK output			

Note: CNR is not turned off in edit mode.

* The APC loop becomes post-comb when pin 16 is set high (trick mode).

Block Diagram

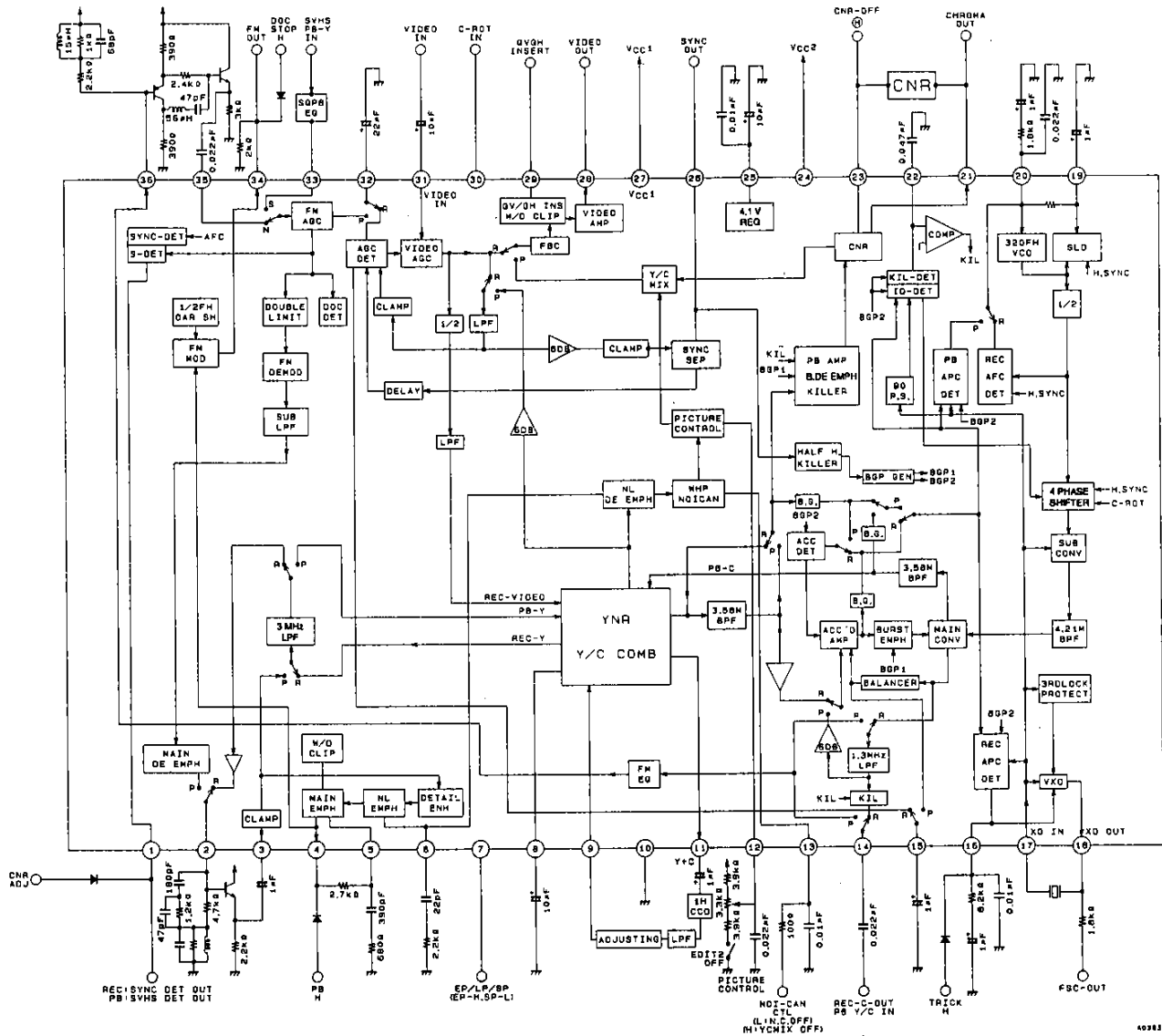

■ No products described or contained herein are intended for use in surgical implants, life-support systems, aerospace equipment, nuclear power control systems, vehicles, disaster/crime-prevention equipment and the like, the failure of which may directly or indirectly cause injury, death or property loss.

■ Anyone purchasing any products described or contained herein for an above-mentioned use shall:

- ① Accept full responsibility and indemnify and defend SANYO ELECTRIC CO., LTD., its affiliates, subsidiaries and distributors and all their officers and employees, jointly and severally, against any and all claims and litigation and all damages, cost and expenses associated with such use;
- ② Not impose any responsibility for any fault or negligence which may be cited in any such claim or litigation on SANYO ELECTRIC CO., LTD., its affiliates, subsidiaries and distributors or any of their officers and employees jointly or severally.

■ Information (including circuit diagrams and circuit parameters) herein is for example only; it is not guaranteed for volume production. SANYO believes information herein is accurate and reliable, but no guarantees are made or implied regarding its use or any infringements of intellectual property rights or other rights of third parties.

This catalog provides information as of May, 1995. Specifications and information herein are subject to change without notice.