



SANYO Semiconductors

DATA SHEET

LA1265 — Monolithic Linear IC FM/AM Tuner of Electronic Tuning Type

Features

- Minimum number of external parts required.
- Excellent S/N.
- Local OSC with ALC.
- Local OSC buffer.
- Tuning indicator pin (common with narrow-band stop signal and muting drive output).
- Variable stop sensitivity (variable separately for FM, AM)
- Low whistle.
- Signal meter pin.

Functions

- FM : IF amplifier, quadrature detector, AF preamplifier, signal meter, tuning indicator drive output (common with stop signal, muting drive output).
- AM : RF amplifier, MIX, OSC (with ALC), IF amplifier, detector, AGC, signal meter, tuning indicator drive output (common with stop signal).

Specifications

Maximum Ratings at Ta = 25°C, See specified Test Circuit.

Parameter	Symbol	Conditions	Ratings	Unit
Maximum supply voltage	V _{CC} max	Pins 7, 8, 17	16	V
Flow-in current	I _g	Pin 8	20	mA
Flow-out current	I ₂₀	Pin 20	1	mA
	I ₂₂	Pin 22	2	mA
Allowable power dissipation	P _d max	Ta ≤ 60°C	650	mW
Operating temperature	T _{opr}		-20 to +70	°C
Storage temperature	T _{stg}		-40 to +125	°C

■ Any and all SANYO Semiconductor Co.,Ltd. products described or contained herein are, with regard to "standard application", intended for the use as general electronics equipment (home appliances, AV equipment, communication device, office equipment, industrial equipment etc.). The products mentioned herein shall not be intended for use for any "special application" (medical equipment whose purpose is to sustain life, aerospace instrument, nuclear control device, burning appliances, transportation machine, traffic signal system, safety equipment etc.) that shall require extremely high level of reliability and can directly threaten human lives in case of failure or malfunction of the product or may cause harm to human bodies, nor shall they grant any guarantee thereof. If you should intend to use our products for applications outside the standard applications of our customer who is considering such use and/or outside the scope of our intended standard applications, please consult with us prior to the intended use. If there is no consultation or inquiry before the intended use, our customer shall be solely responsible for the use.

■ Specifications of any and all SANYO Semiconductor Co.,Ltd. products described or contained herein stipulate the performance, characteristics, and functions of the described products in the independent state, and are not guarantees of the performance, characteristics, and functions of the described products as mounted in the customer's products or equipment. To verify symptoms and states that cannot be evaluated in an independent device, the customer should always evaluate and test devices mounted in the customer's products or equipment.

SANYO Semiconductor Co., Ltd.

TOKYO OFFICE Tokyo Bldg., 1-10, 1 Chome, Ueno, Taito-ku, TOKYO, 110-8534 JAPAN

51408 MS JK/N2897HA (KT)/40194HK/O077KI/D095KI/2255KI, TS No.1820-1/15

LA1265

Operating Conditions at $T_a = 25^\circ\text{C}$

Parameter	Symbol	Conditions	Ratings	Unit
Recommended operating voltage	V_{CC}		8.5	V
Operating voltage range	$V_{CC\ op}$		6 to 14	V

Electrical Characteristics at $T_a = 25^\circ\text{C}$, $V_{CC} = 8.5\text{V}$, See specified Test Circuit

Parameter	Symbol	Conditions	Ratings			Unit
			min	typ	max	
AM : f = 1MHz						
Quiescent current	I_{CCO}	No input		18	26	mA
Detection output	V_{O1}	$V_{IN} = 20\text{dB}\mu$, 400Hz, 30% mod.	30	50	90	mV
	V_{O2}	$V_{IN} = 80\text{dB}\mu$, 400Hz, 30% mod.	110	160	220	mV
S/N	S/N1	$V_{IN} = 20\text{dB}\mu$	16	20		dB
	S/N2	$V_{IN} = 80\text{dB}\mu$	49	54		dB
Total harmonic distortion	THD1	$V_{IN} = 80\text{dB}\mu$, 400Hz, 30% mod.		0.3	1.0	%
	THD2	$V_{IN} = 107\text{dB}\mu$, 400Hz, 30% mod.		0.5	2.0	%
Signal meter output	$V_{SM\ 1}$	No input	0	0	0.2	V
	$V_{SM\ 2}$	$V_{IN} = 80\text{dB}\mu$	2.4	2.8	3.1	V
LED lighting sensitivity	$V_{LED\ on}$	$I_{LED} = 1\text{mA}$	15	24	33	$\text{dB}\mu$
Local OSC buffer output	V_{OSC}	$f_{OSC} = 1.45\text{MHz}$	220	275	330	mV
FM : f = 10.7MHz						
Quiescent current	I_{CCO}	No input		20	28	mA
Input limiting sensitivity	-3dBLS.	3dB down, 400Hz, 100% mod.		31	37	$\text{dB}\mu$
Demodulation output	V_O	$V_{IN} = 10\text{dB}\mu$, 400Hz, 100% mod.	240	330	460	mV
S/N	S/N	$V_{IN} = 100\text{dB}\mu$	78	84		dB
Total harmonic distortion	THD	$V_{IN} = 100\% \text{ dB}\mu$, 400Hz, 100% mod.		0.03	0.3	%
Signal meter output	$V_{SM\ 1}$	No input	0	0	0.2	V
	$V_{SM\ 2}$	$V_{IN} = 100\text{dB}\mu$	1.5	2.7	3.1	V
LED lighting sensitivity	LED-on	$I_{LED} = 1\text{mA}$	35	50	65	$\text{dB}\mu$
LED lighting bandwidth	LED-BW	$V_{IN} = 100\text{dB}$, $I_{LED} = 1\text{mA}$	90	120	160	kHz
AM rejection ratio	AMR	$V_{IN} = 100\text{dB}\mu$, FM = 400Hz 100% mod. AM = 1kHz 30% mod.	45	60		dB

LA1265

Package Dimensions

unit : mm (typ)

3059A

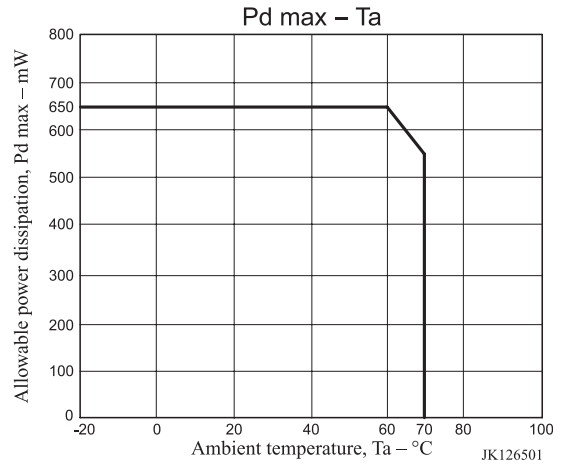
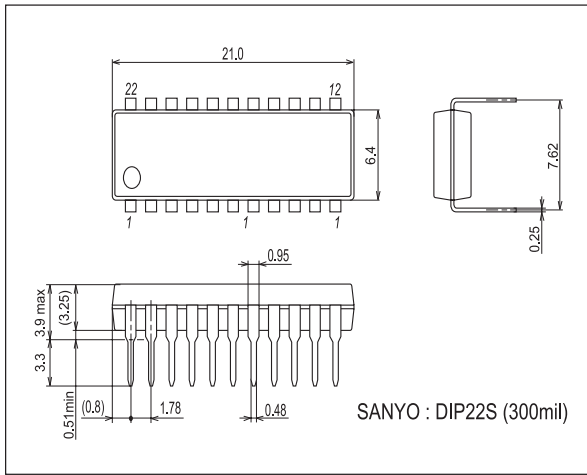

Block Diagram

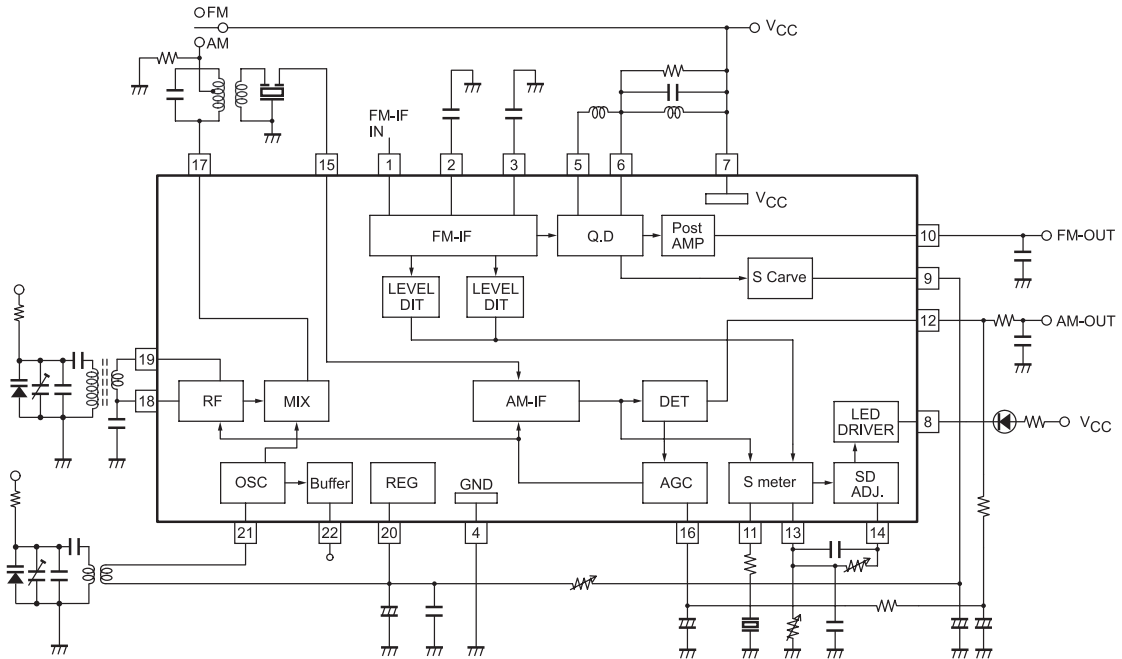

How to use the LA1265

1. LED lighting, muting drive output, stop signal (SD).

- For LED lighting, muting drive output, stop signal, the output at pin 8 is used.
- The voltage on pin 8, when tuned, turns from "H" to "L". (Active-Low)
- Signal bandwidth at pin 8.

– For AM, the bandwidth depends on the CF (BFU450CN) at pin 11. If a capacitor is connected in place of the CF, the bandwidth will get wider.

– For FM, the bandwidth depends on the resistance across pins 9 and 20. If the resistance is increased, the bandwidth will get narrower. R = 15kΩ makes the bandwidth approximately 120kHz.

- Sensitivity adjustment of LED, muting, stop signal.
 - For FM, the semifixed variable resistor across pin 13 and GND is used.
 - For AM, the semifixed variable resistor across pins 13 and 14 is used. Be sure to start adjustment for FM, and then make adjustment for AM. For the stop signal sensitivity and FM stop signal bandwidth, the variations should be considered and it is recommended to use the semifixed variable resistor for adjustment.

• LED lighting sensitivity setting for AM.

For the LED lighting sensitivity setting for AM, it is desirable that the IC input be 30dBμ (antenna input : approximately 50dB/m). In this case, the value of VR1 is 30kΩ.

• LED lighting sensitivity setting for FM.

– For the LED lighting sensitivity setting for FM, the IC input may be 45dBμ to 60dBμ. With the variations in the front end considered, it is ideal that the IC input in a standard receiving set be 51dBμ to 54dBμ. The lower value of VR2 for the LED lighting sensitivity setting is as illustrated right. Since the variations in the front end cause the IC input setting sensitivity to vary, it is recommended to use a value of VR2 at an input voltage lower than a standard setting by 6dB or greater. For example, if IC input 53dBμ is taken as a standard, use VR2 ≤ 100kΩ at IC input 47dBμ.

LED Lighting Bandwidth – Resistance across pins 9 and 20

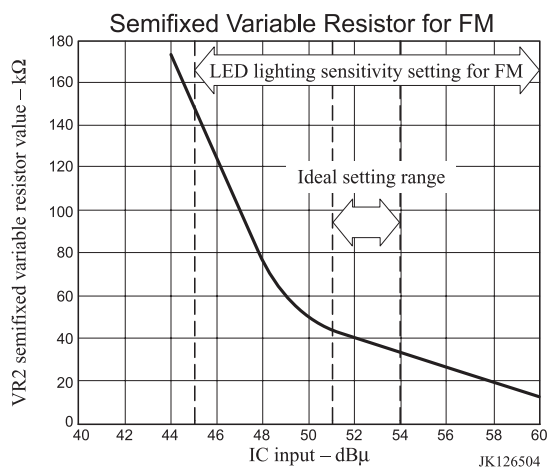
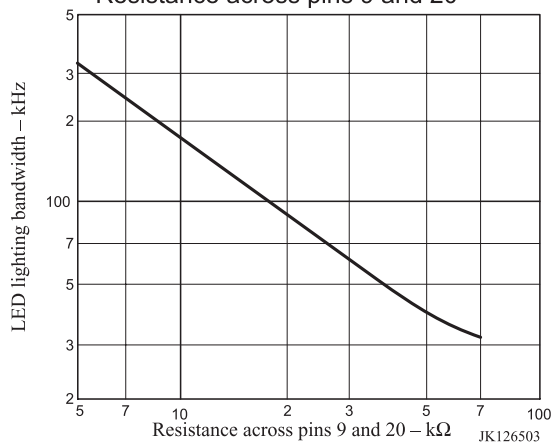

2. AM/ FM changeover

- Two selections are available for changeover as shown below : (A) pin 17-used method and (B) pin 18-used method.
- For (A), the voltage on pin 17 relative to V_{CC} (pin 7) must be within the range of -0.8V to +0.1V. If not within this range, distortion and selectivity will get worse.
- For (A), a resistance of 68kΩ at the IFT cold terminal, which is used to prevent the changeover circuit from malfunctioning, must be connected.

(A) pin 17-use method for AM/FM changeover

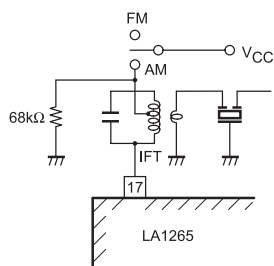

(B) Pin 18-used method for AM/FM changeover

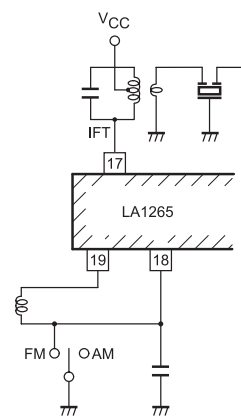

3. Local OSC buffer output

- When local OSC buffer output wave form is saw-toothed at the SW mode, connect a resistance of 1.2kΩ or thereabouts across pin 22 and GND.

4. AM input pin

- It is desirable that the AM input pin (pin 19) be L-coupled to pin 18.
- Inputting to pin 19 can be done by DC-cutting with a capacitor. However, an unbalance in the RF amplifier (differential amplifier) causes gain drop and whistle worsening.

5. Capacitance across pin 9 and GND.

A large capacitance across pin 9 and GND may cause a misstop at an adjacent channel when the channel select speed is made faster at the automatic channel select mode. In this case, decrease the capacitance across pin 9 and GND. However, if too decreased, the LED will flutter at low modulation frequencies at the time of detuning. Therefore, it is recommended to fix the capacitance across pin 9 and GND to be 3.3μF to 10μF. The relation between modulation frequency and demodulation output voltage on pin 9 with the capacitance across pin 9 and GND as a parameter is shown right.

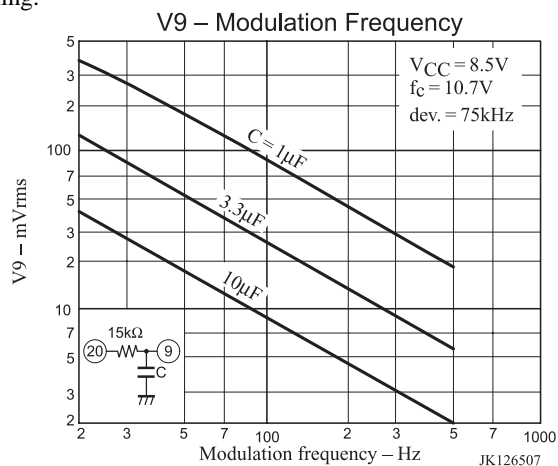

6. If the coupling coefficient of the local OSC coil is small and an antiresonance point of approximately 100MHz is present or the stray capacitance across pins 22 and 21 is large, a parasitic oscillation of approximately 100MHz may occur in the buffer output (pin 22). In this case, connect a capacitance of approximately 30pF across pin 22 and GND.

7. AM OSC coil

Generally speaking, the following should be noted. Avoid winding with loose coupling between primary side and secondary side (especially SW1, SW2).

To put it concretely, the pot core type is better than the screw core type which is loose in coupling. This prevents the local OSC frequency from turning third resonance frequency related to the coupling coefficient.

8. Resistance across pin 8 and VDD.

If pin 8 is used for the stop signal (SD) only, without using LED, it is recommended to fix resistance RL across pin 8 and GND to be 51kΩ to 100kΩ.

9. To prevent whistle from worsening, make the pattern of AM output pin 12 as short as possible.

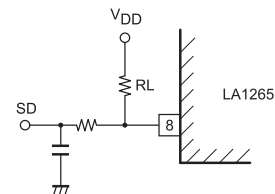

Input/Output Admittance

FM

IF	Parameter	Frequency	Admittance		Unit
			r _i	c _i	
	γ _{i1}	10.7MHz	330	20	Ω pF

AM

	Parameter	Frequency	-	Admittance		Unit
				AGC-off (V16 = 1.4V)	AGC-on (V16 = 2.5V)	
RF	γ _{i19}	1MHz	r _i	15	16	kΩ
			c _i	4	4	pF
MIX	γ _{o17}	500kHz	r _o	-	-	kΩ
			c _o	3	3	pF
IF	γ _{i15}	500kHz	r _i	2	2	kΩ
			c _o	10	8	pF

LA1265

Test Circuit : FM, AM-MW

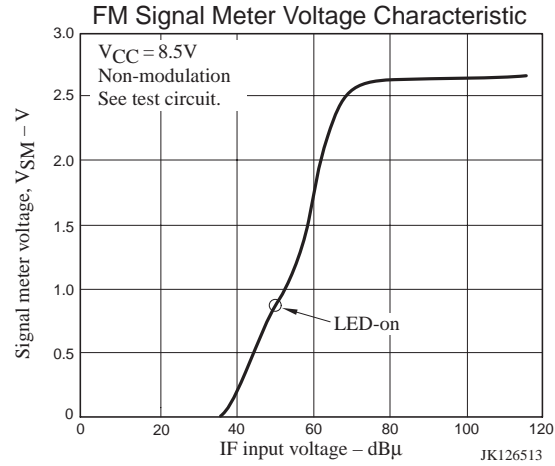
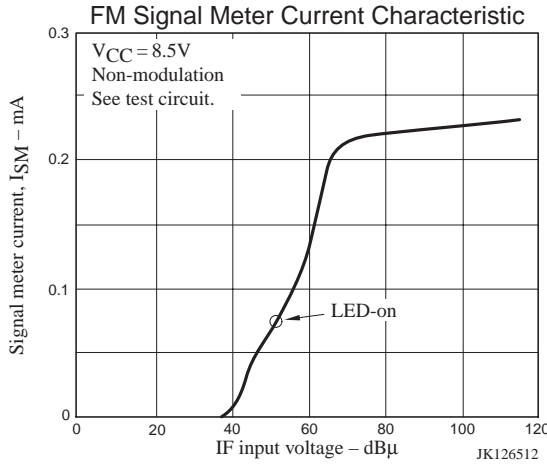
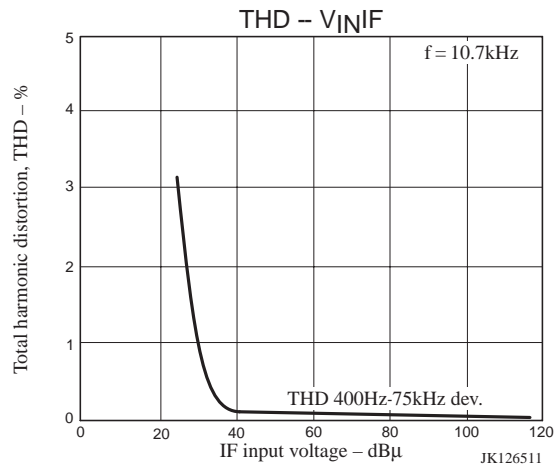
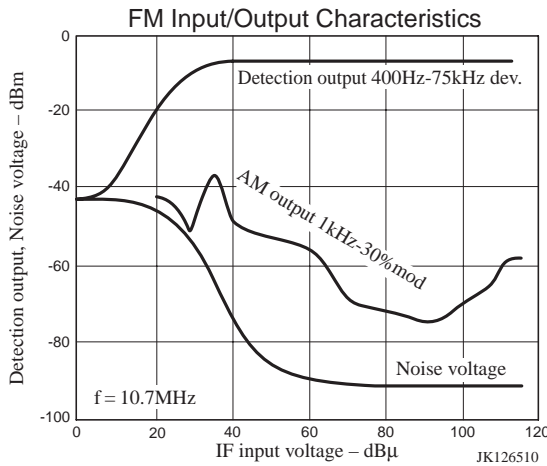
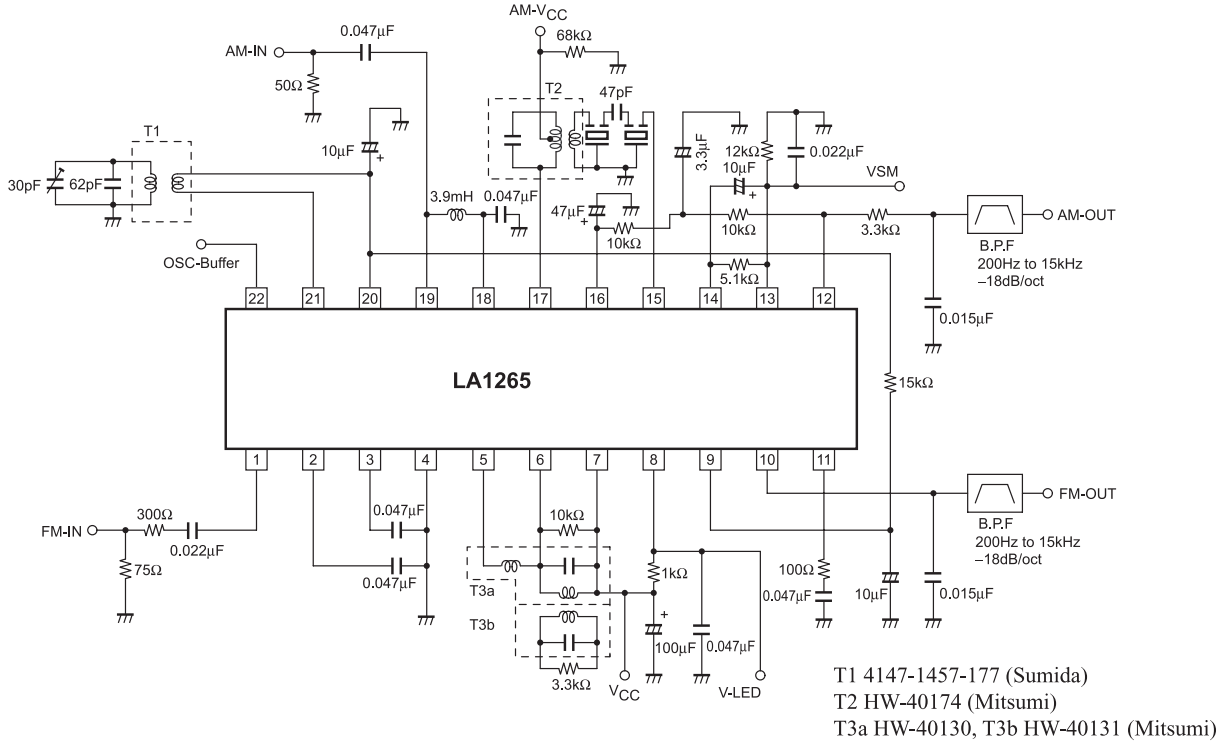

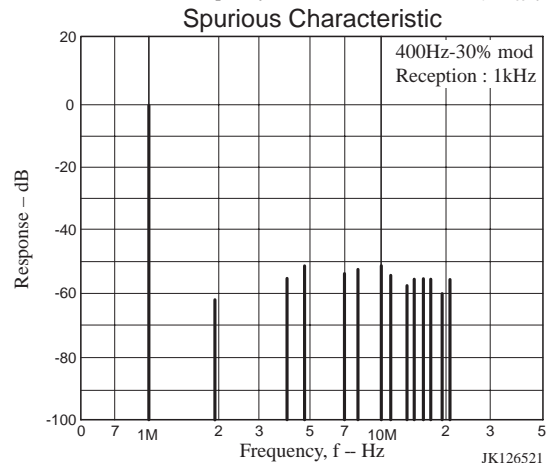
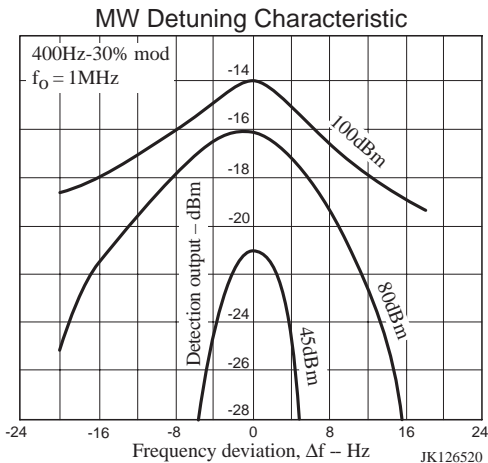
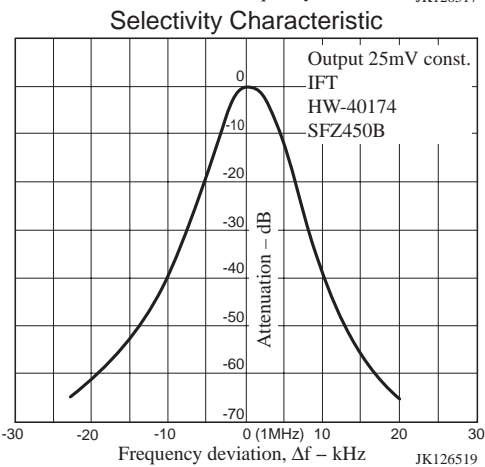
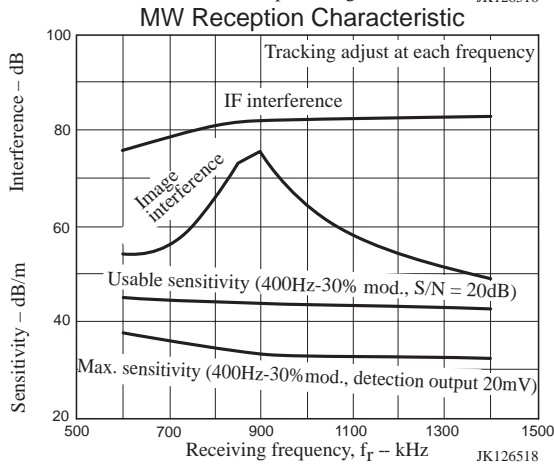
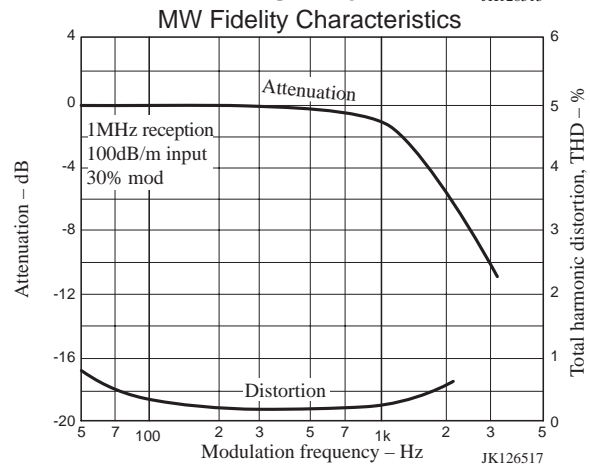
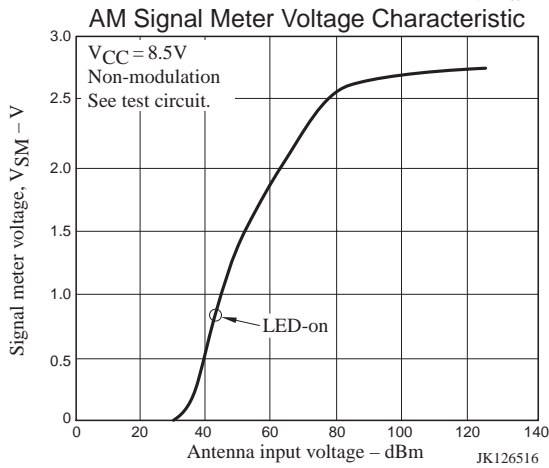
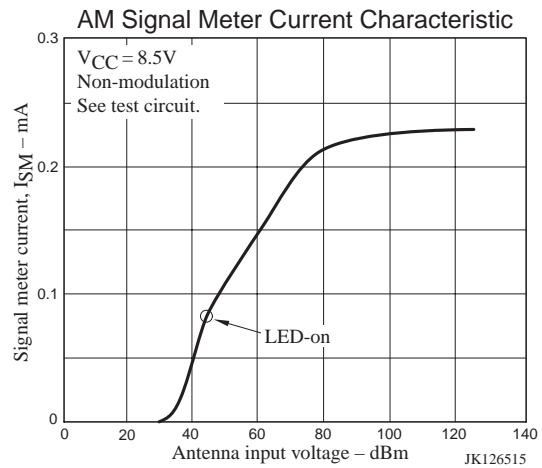
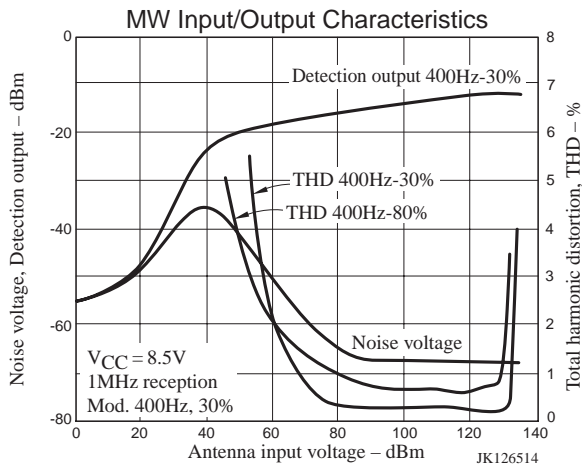

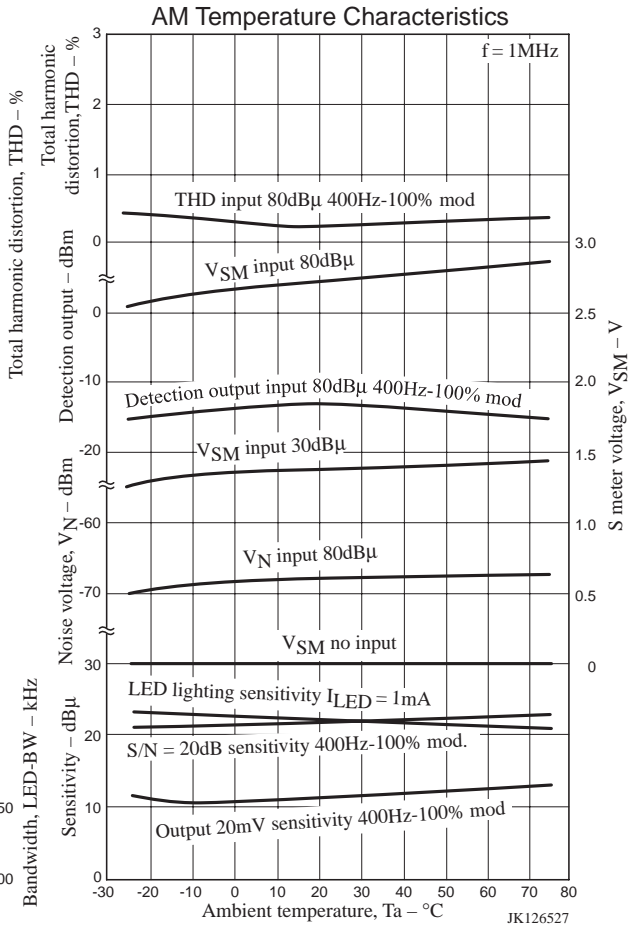
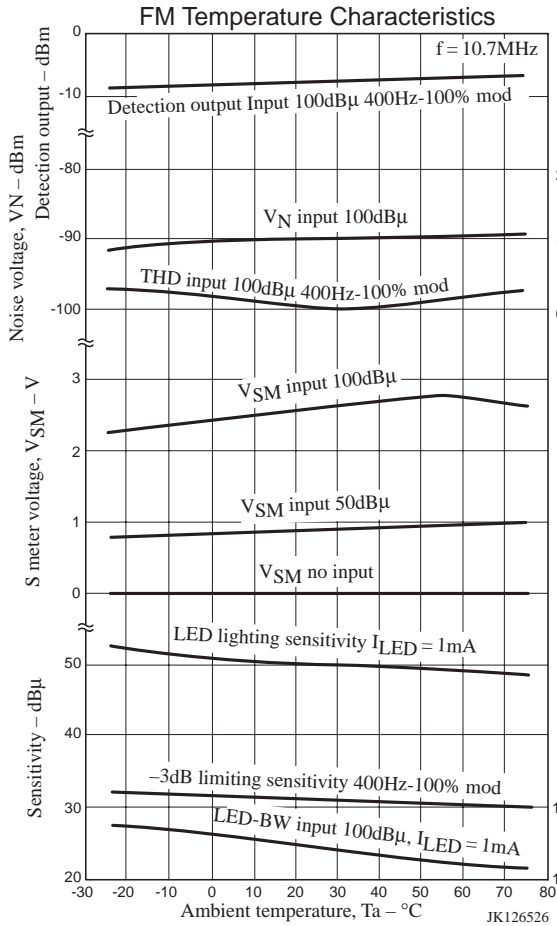
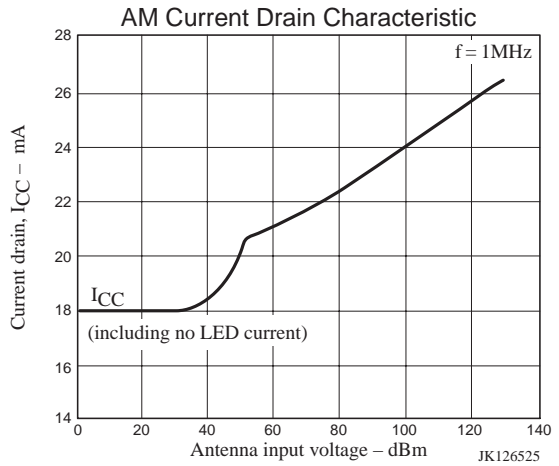
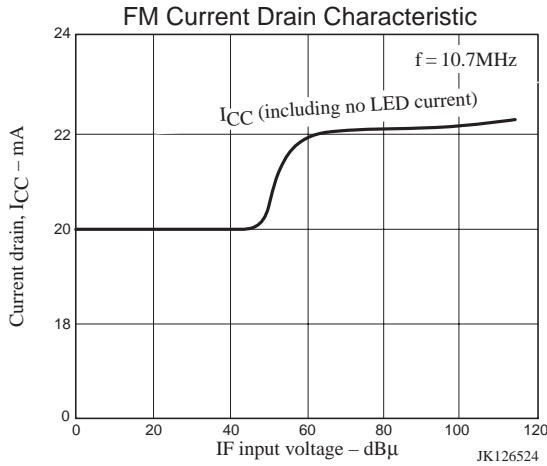
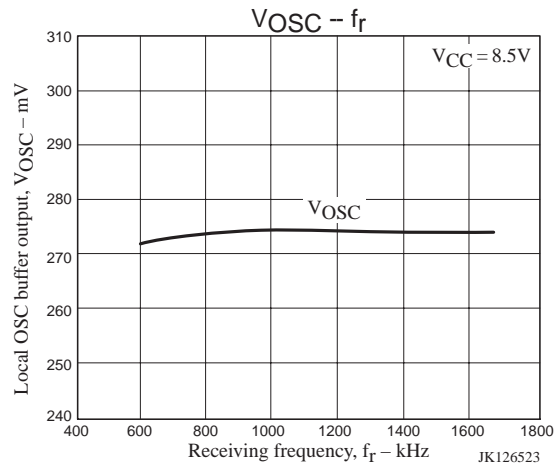
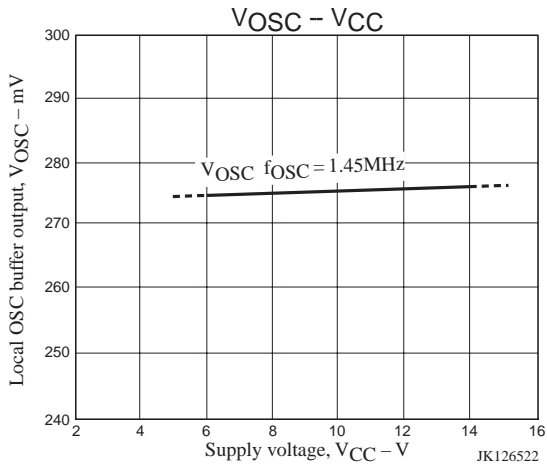

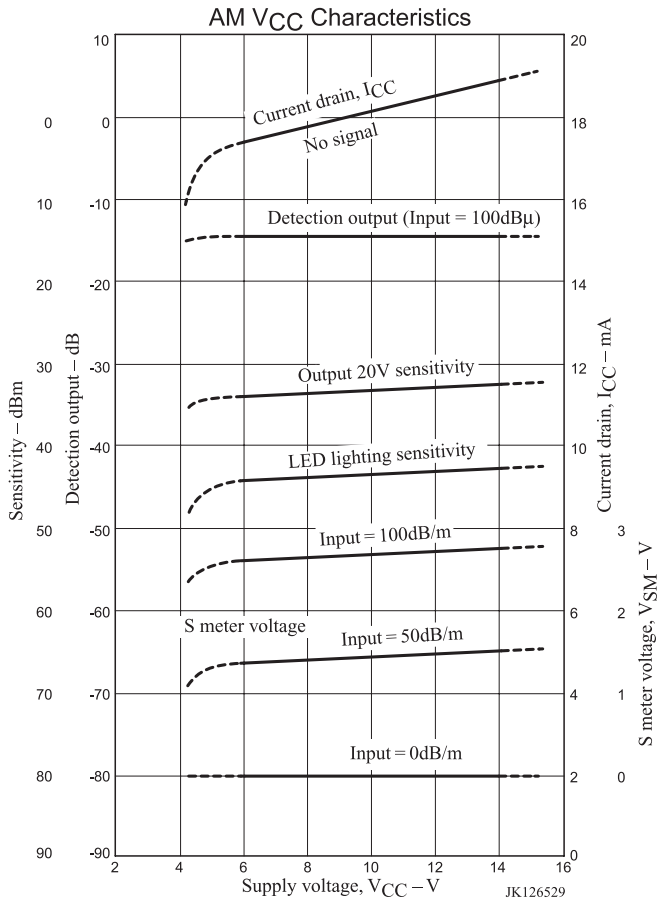
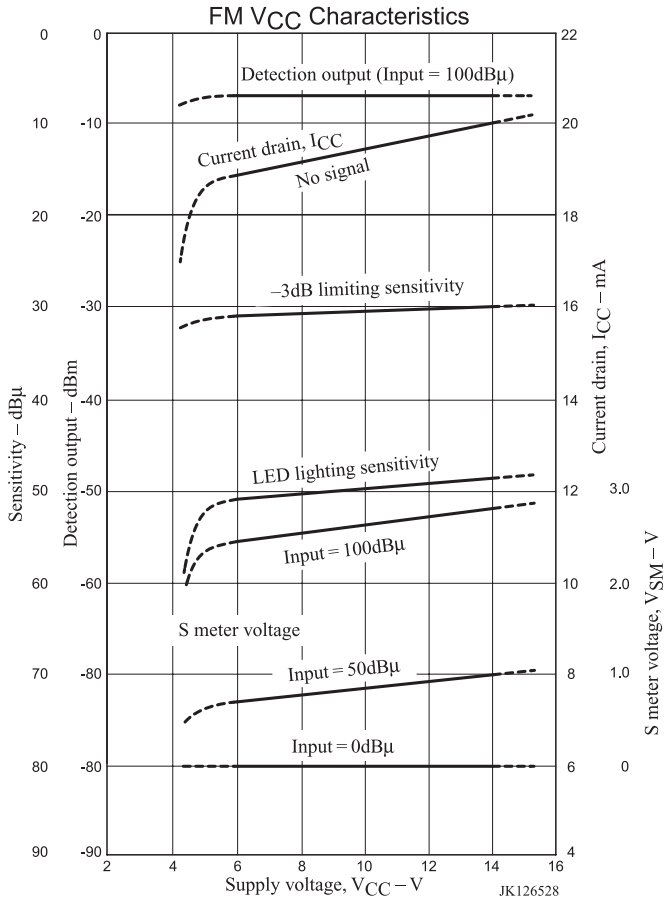

LA1265

Test Circuit : SW2

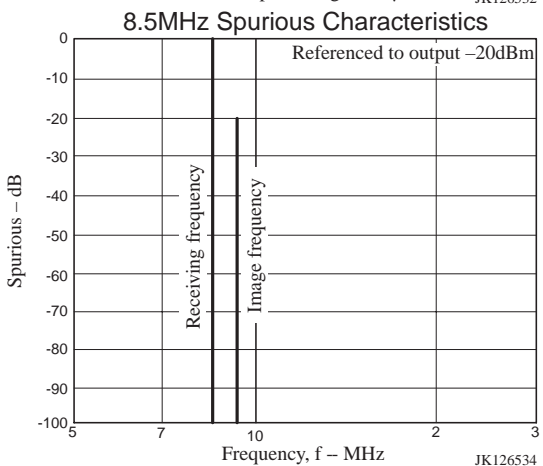
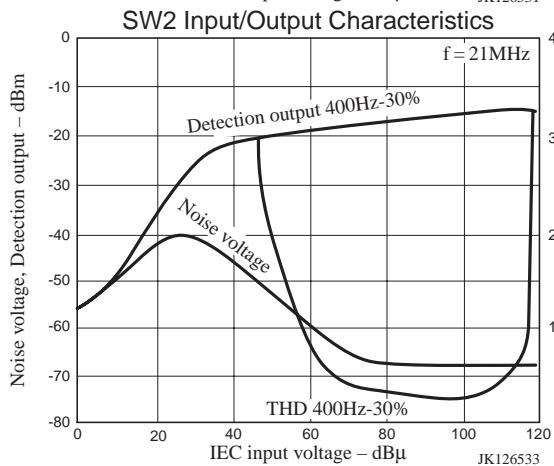
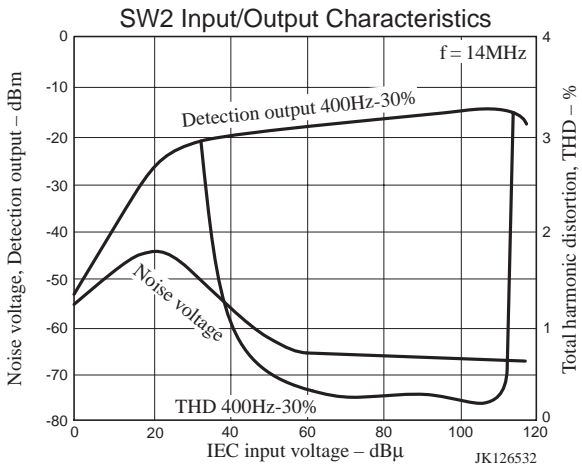
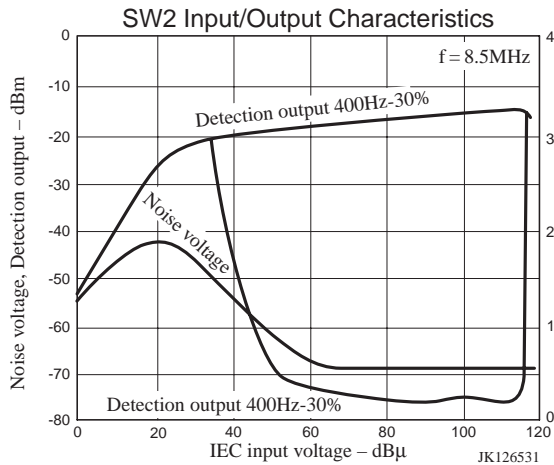
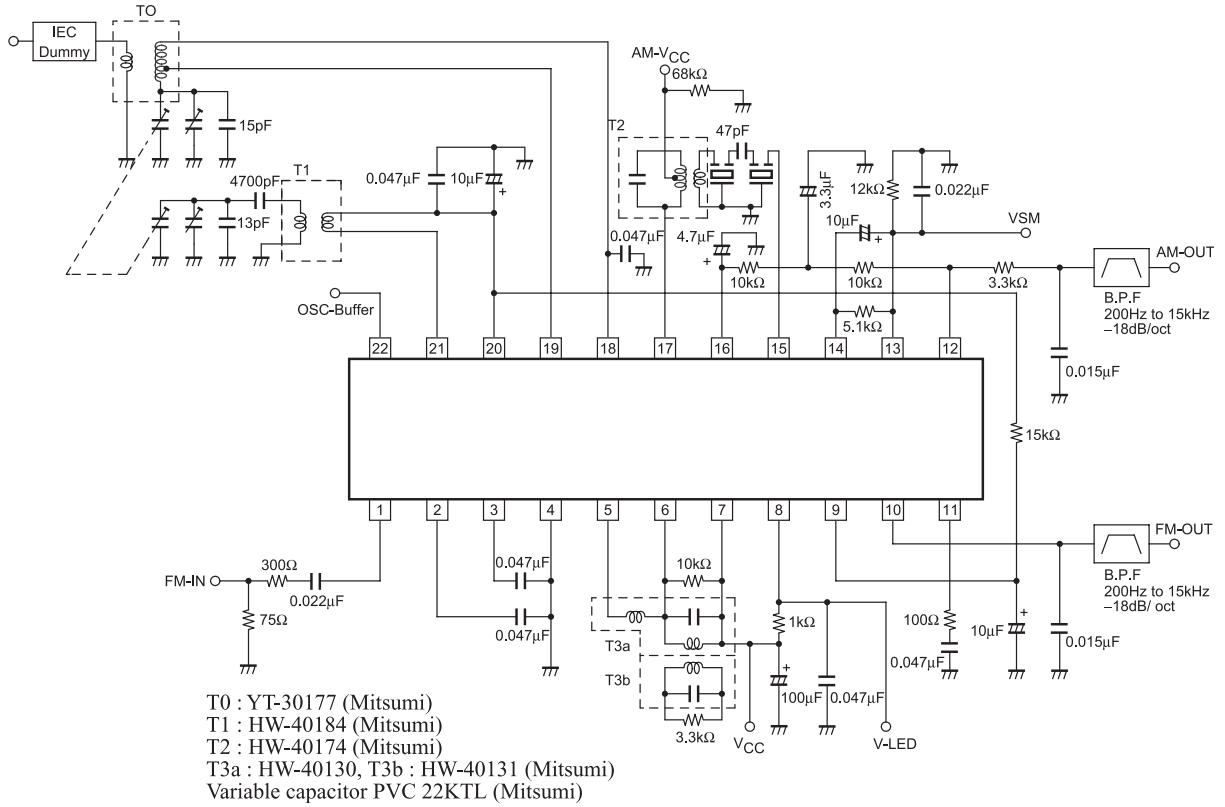

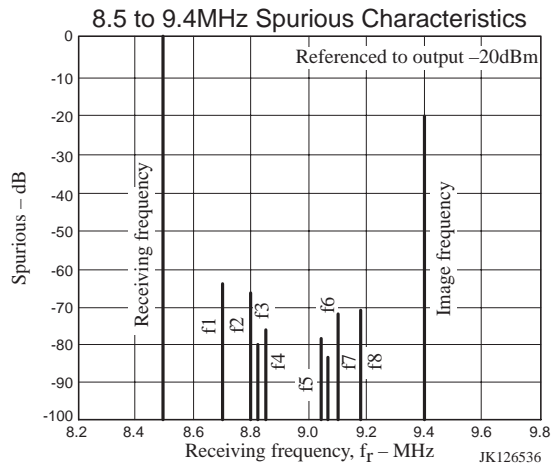
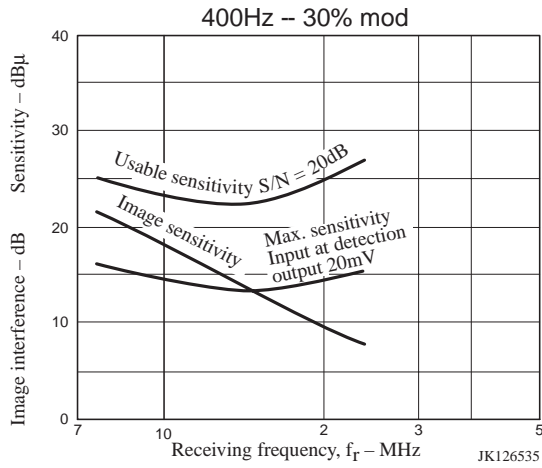

- f1 : 8.724MHz $\rightarrow 2f_{OSC} - 2f_1 = 455\text{kHz}$
- f2 : 8.799MHz $\rightarrow 3f_{OSC} - 3f_2 = 455\text{kHz}$
- f3 : 8.836MHz $\rightarrow 4f_{OSC} - 4f_3 = 455\text{kHz}$
- f4 : 8.859MHz $\rightarrow 5f_{OSC} - 5f_4 = 455\text{kHz}$
- f5 : 9.038MHz $\rightarrow 5f_5 - 5f_{OSC} = 455\text{kHz}$
- f6 : 9.061MHz $\rightarrow 4f_6 - 4f_{OSC} = 455\text{kHz}$
- f7 : 9.098MHz $\rightarrow 3f_7 - 3f_{OSC} = 455\text{kHz}$
- f8 : 9.173MHz $\rightarrow 2f_8 - 2f_{OSC} = 455\text{kHz}$

Coil Specifications

MW antenna

Bar antenna (for PVC22KTL)

- TN-10896 (Mitsumi)

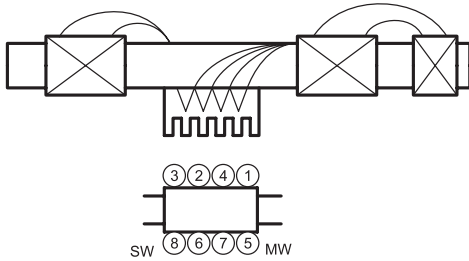

- ①-② 22T, +49T, ③-④ 10T
- Tight solenoid direct winding
- ⑤-⑥ 17T 0.5φ space winding
- ⑦-⑧ 4T tight solenoid winding
- ①-② $L = 260\mu\text{H}$, $Q_0 = 330 (\geq 200)$
- ⑤-⑥ $L = 15\mu\text{H}$, $Q_0 = 250 (\geq 150)$

Loop antenna (for SVC321)

- LA300 (Korin Giken)

Loop antenna matching coil

- KT-412

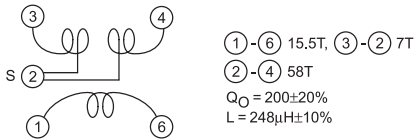

MW OSC

- 4147-1457-177 (Sumida)

For PVC22KTL

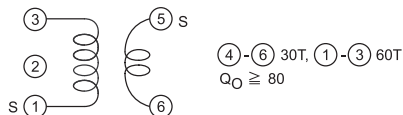

- KO-387 (Korin Giken)

For SVC321

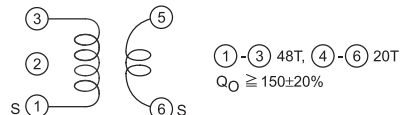

AM-IFT

Matching coil for SFU450B (1-element type)

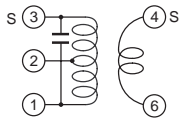

·HW-40173 (Mitsumi)
 (1)-(2) 82T, (3)-(2) 70T
 (4)-(6) 7T
 $Q_0 = 110 \pm 20\%$, $f = 450\text{kHz}$
 Internal 180pF

·2150-2162-197 (Sumida)
 (1)-(2) 103T, (3)-(2) 71T
 (4)-(6) 8T
 $Q_0 \geq 80$, $f = 450\text{kHz}$
 Internal 180pF

Matching coil for SFZ450B (2-element type)

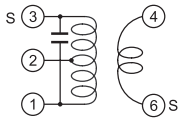

·HW-40174 (Mitsumi)
 (1)-(2) 58T, (3)-(2) 94T,
 (4)-(6) 10T
 $Q_0 = 80 \pm 20\%$, $f = 10.7\text{kHz}$
 Internal 180pF

·2150-2061-049 (Sumida)
 (1)-(2) 54T, (3)-(2) 120T
 (4)-(6) 12T
 $Q_0 \geq 40$
 Internal 180pF

FM single tuning detection coil

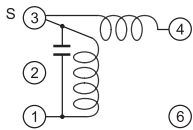

·HW-40122 (Mitsumi)
 (3)-(4) 84.5T, (3)-(1) 19T,
 $Q_0 = 35 \pm 20\%$, $f = 10.7\text{MHz}$
 Internal 82pF $\pm 10\%$
 Damping resistance

·2231-016 (Sumida)
 (3)-(4) 73.5T, (3)-(1) 19T,
 $Q_0 = 30 \pm 20\%$, $f = 10.7\text{MHz}$
 Internal 82pF $\pm 10\%$
 Damping resistance

FM double tuning detection coil

HW-40130

HW-40131

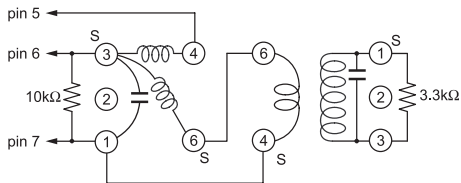

·HW-40130 (Mitsumi)
 (3)-(4) 86.5T
 (3)-(6) 13.5T
 $Q_0 = 50 \pm 20\%$
 Internal 100pF $\pm 10\%$

·HW-40131 (Mitsumi)
 (4)-(6) 1T
 (1)-(3) 19T
 $Q_0 = 35 \pm 20\%$
 Internal 100pF $\pm 10\%$

2231-096

2231-097

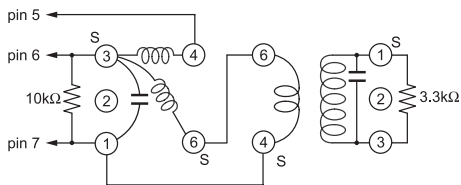

·2231-096 (Sumida)
 (3)-(4) 73.5T
 (3)-(6) 23.5T
 $Q_0 = 50 \pm 20\%$
 Internal 62pF $\pm 10\%$

·2231-097 (Sumida)
 (4)-(6) 2T
 (1)-(3) 21T
 $Q_0 = 47 \pm 20\%$
 Internal 82pF $\pm 10\%$

LA1265

Sample Application Circuit : LA1186N+LA1265 (US Band)

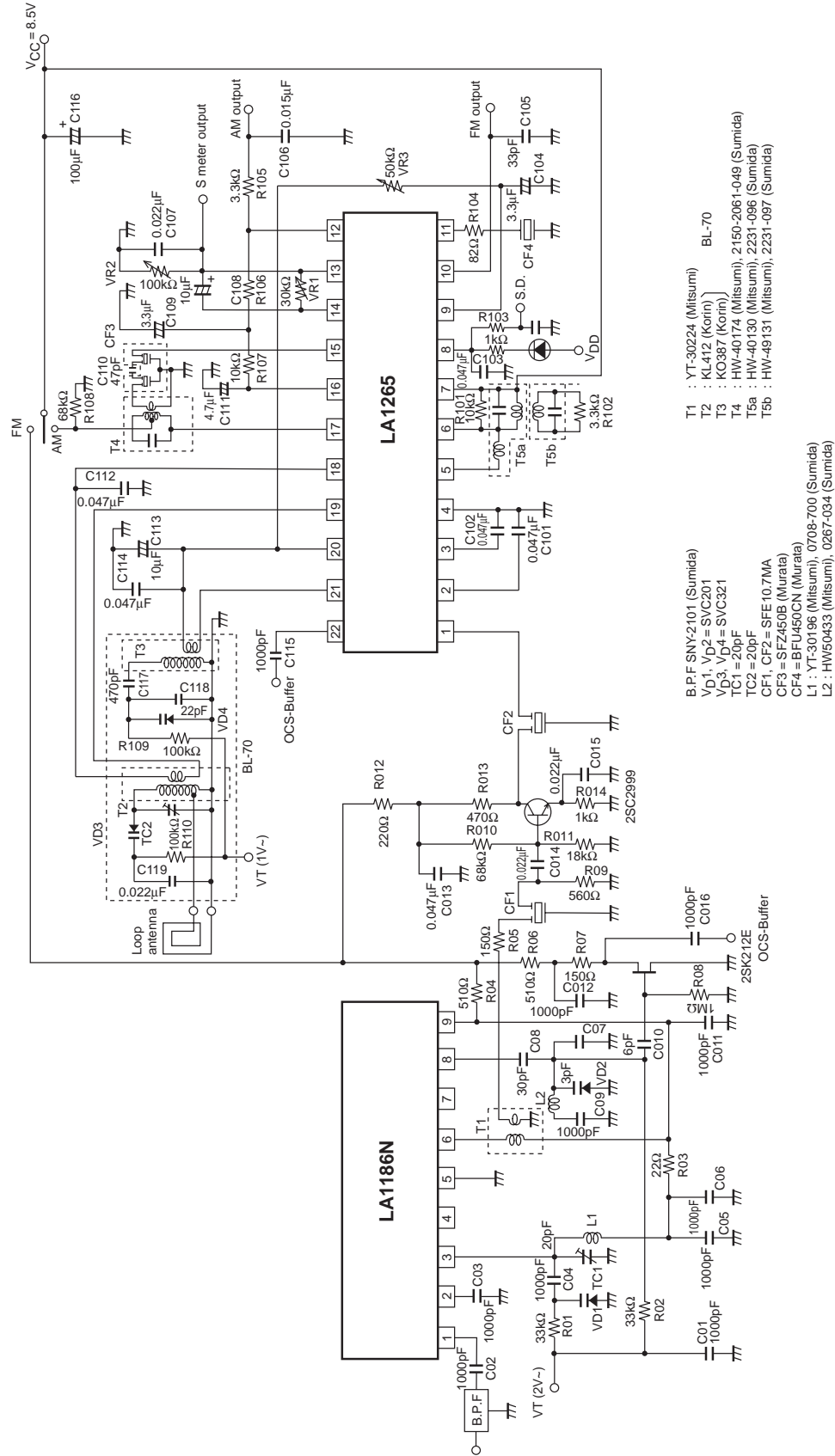

LA1265

Sample Printed Circuit Pattern (Cu-foiled area)

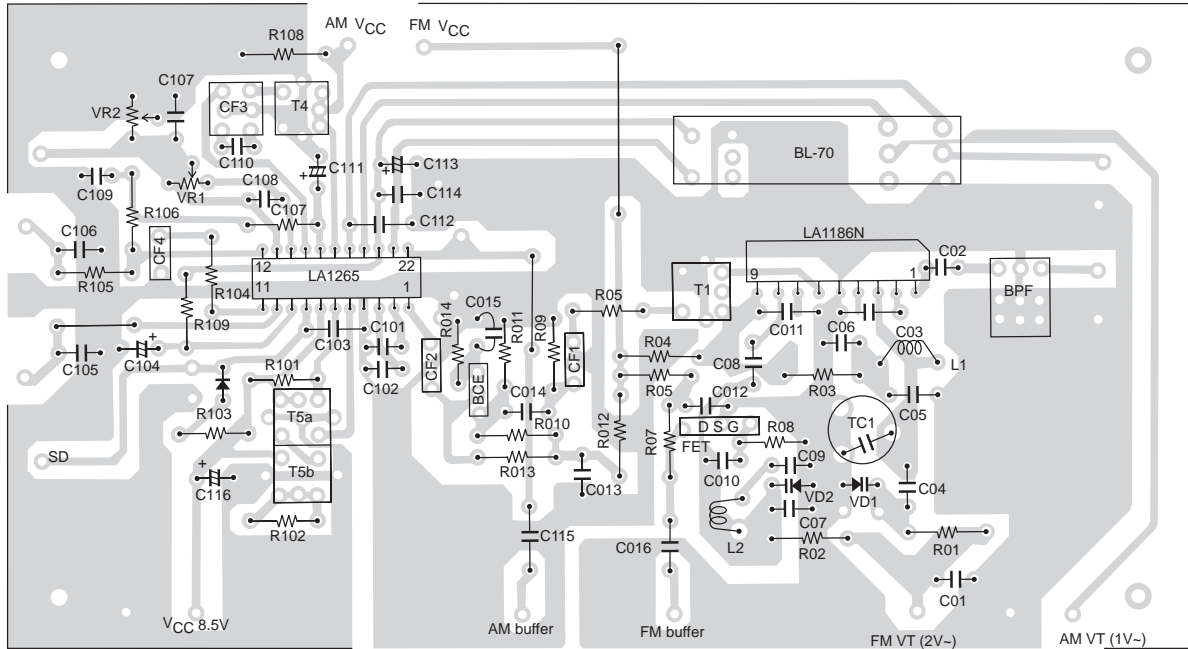

85 × 155mm²

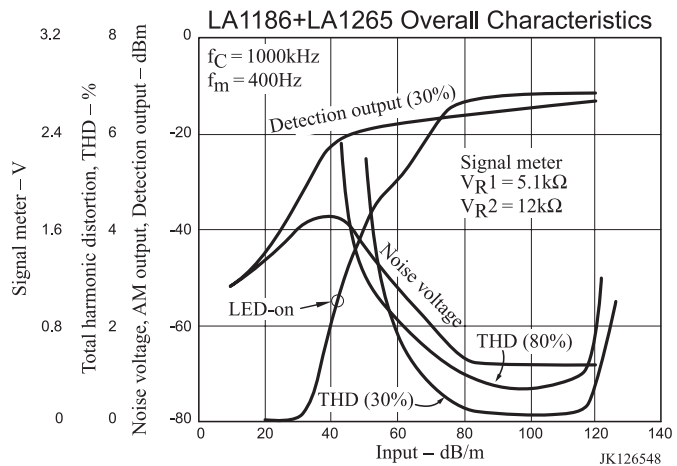
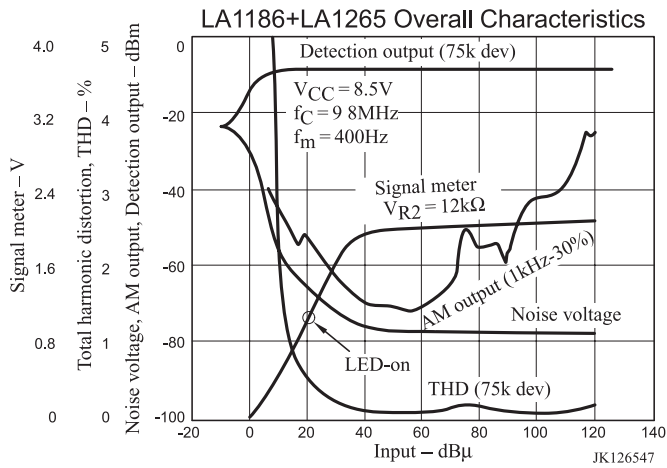

- SANYO Semiconductor Co.,Ltd. assumes no responsibility for equipment failures that result from using products at values that exceed, even momentarily, rated values (such as maximum ratings, operating condition ranges, or other parameters) listed in products specifications of any and all SANYO Semiconductor Co.,Ltd. products described or contained herein.
- SANYO Semiconductor Co.,Ltd. strives to supply high-quality high-reliability products, however, any and all semiconductor products fail or malfunction with some probability. It is possible that these probabilistic failures or malfunction could give rise to accidents or events that could endanger human lives, trouble that could give rise to smoke or fire, or accidents that could cause damage to other property. When designing equipment, adopt safety measures so that these kinds of accidents or events cannot occur. Such measures include but are not limited to protective circuits and error prevention circuits for safe design, redundant design, and structural design.
- In the event that any or all SANYO Semiconductor Co.,Ltd. products described or contained herein are controlled under any of applicable local export control laws and regulations, such products may require the export license from the authorities concerned in accordance with the above law.
- No part of this publication may be reproduced or transmitted in any form or by any means, electronic or mechanical, including photocopying and recording, or any information storage or retrieval system, or otherwise, without the prior written consent of SANYO Semiconductor Co.,Ltd.
- Any and all information described or contained herein are subject to change without notice due to product/technology improvement, etc. When designing equipment, refer to the "Delivery Specification" for the SANYO Semiconductor Co.,Ltd. product that you intend to use.
- Information (including circuit diagrams and circuit parameters) herein is for example only; it is not guaranteed for volume production.
- Upon using the technical information or products described herein, neither warranty nor license shall be granted with regard to intellectual property rights or any other rights of SANYO Semiconductor Co.,Ltd. or any third party. SANYO Semiconductor Co.,Ltd. shall not be liable for any claim or suits with regard to a third party's intellectual property rights which has resulted from the use of the technical information and products mentioned above.

This catalog provides information as of May, 2008. Specifications and information herein are subject to change without notice.