

SANYO	No.4805B	LA1832, 1832M
	Support for AM Stereo and Electronic Tuning Radio Cassette Recorder/Music Center-Use Single-Chip IC (AM/FM IF + MPX)	

Overview

The LA1832 and 1832M are single-chip AM/FM IF and MPX tuner ICs that support electronic tuning. These chips were developed for consumer audio systems and is optimal for auto-seek systems based on IF count methods used together with SD.

Since no adjustments are required in the FM detector and MPX VCO circuits, use of these chips can significantly reduce the number of adjustment steps in the end-product manufacturing line.

Functions

- AM:** RF amplifier, mixer, oscillator (with ALC), IF amplifier, detector AGC, oscillator buffer, tuning indicator, IF buffer output, stereo IF output.
- FM IF:** IF amplifier, quadrature detector, S curve detection, tuning indicator, IF buffer output, S-meter
- MPX:** PLL stereo decoder, stereo indicator, forced mono, VCO stop

Features

- Major reduction in required adjustments
 - FM detector: No adjustments (ceramic discriminator used)
 - MPX VCO: No adjustments (ceramic resonator used)
- Tuning indicator pin provided (can be used as a narrowband stop signal or a muting drive output): SD output
- Supports IF count scheme
- Built-in SD time constant switching circuit
- Variable FM stop sensitivity and bandwidth
- Built-in AM local oscillator buffer
- Supports AM low-cut control
- Pin compatibility with the LA1831 (See page 9 for details on the differences between the LA1832 and the LA1831.)
- Built-in IF output function for AM stereo

Specifications

Maximum Ratings at $T_a = 25^\circ\text{C}$

Parameter	Symbol	Conditions	Ratings	Unit
Maximum supply voltage	$V_{CC \text{ max}}$		9.0	V
Indicator drive current	I_{LED}	Pins 6 and 7	20	mA
Allowable power dissipation	$P_d \text{ max}$	$T_a \leq 70^\circ\text{C}$ (LA1832)	400	mW
		$T_a \leq 70^\circ\text{C}$ (LA1832M)	270	mW
Operating temperature	T_{opr}		-20 to +70	$^\circ\text{C}$
Storage temperature	T_{stg}		-40 to +125	$^\circ\text{C}$

Package Dimensions

unit: mm

3067-DIP24S

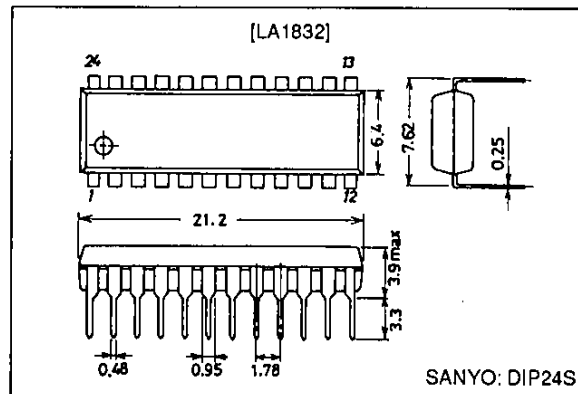

3112-MFP24S

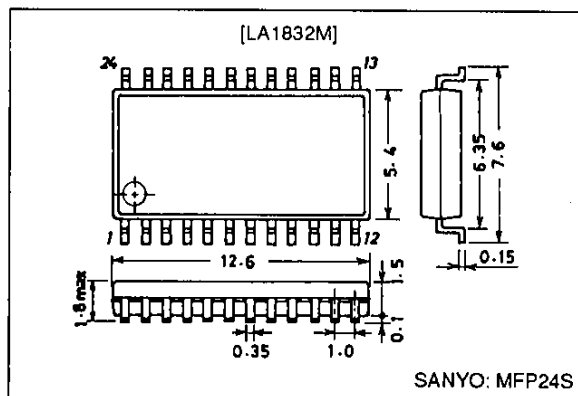

SANYO Electric Co., Ltd. Semiconductor Business Headquarters

TOKYO OFFICE Tokyo Bldg., 1-10, 1 Chome, Ueno, Taito-ku, TOKYO, 110 JAPAN

30395TH (OT) No. 4805-1/15

LA1832, 1832M

Operating Conditions at $T_a = 25^\circ\text{C}$

Parameter	Symbol	Ratings	Unit
Recommended supply voltage	V_{CC}	5.0	V
Operating supply voltage range	$V_{CC\text{ op}}$	4.0 to 8.0	V

Operating Characteristics at $T_a = 25^\circ\text{C}$, $V_{CC} = 5.0\text{ V}$, (for the specified test circuits)

FM Characteristics (mono): $f_c = 10.7\text{ MHz}$, $f_m = 1\text{ kHz}$

Parameter	Symbol	Conditions	min	typ	max	Unit
Quiescent current	I_{CCO-FM}	No input	12	23	33	mA
Demodulation output	V_{O-FM}	100 dB μ , 100% mod, pin 14 output	290	410	580	mVrms
Channel balance	C.B	100 dB μ , 100% mod, ratio of pin 14 to pin 15	-1.5	0	+1.5	dB
Total harmonic distortion (mono)	THD-FMmono	100 dB μ , 100% mod, pin 14 output*		0.3	1.5	%
Signal to noise ratio	S/N-FM	100 dB μ , 100% mod, pin 14 output	68	76.5		dB
Input limiting voltage	-3 dB L.S	With an input reference of 100 dB μ , the IF input that reduces the output by 3 dB		32	40	dB μ
LED sensitivity	$V_{LED-SENS}$	The IF input that turns the TU-LED on	34	44	54	dB μ
LED bandwidth	LED-BAND	The frequency bandwidth that turns the TU-LED on	100	160	230	kHz
IF count buffer output	$V_{IFBUFF-FM}$	The pin 10 output for 100 dB μ , no modulation	90	130	180	mVrms

Note: Using a discriminator with guaranteed band characteristics with a THD under 0.5% (10.7 MHz \pm 20 kHz)

FM Characteristics (stereo): $f_c = 10.7\text{ MHz}$, $f_m = 1\text{ kHz}$, $L + R = 90\%$, $PILOT = 10\%$, $V_{IN} = 100\text{ dB}\mu$

Parameter	Symbol	Conditions	min	typ	max	Unit
Separation	Sep	Pin 14 output	30	45		dB
Stereo on level	ST-ON	The pilot modulation level for which V_7 becomes less than 1.5 V	1.5	3.0	5.0	%
Total harmonic distortion (main)	THD-Main	Pin 14 output*		0.3	1.5	%

Note: Using a discriminator with guaranteed band characteristics with a THD under 0.5% (10.7 MHz \pm 20 kHz)

AM Characteristics: $f_c = 1000\text{ kHz}$, $f_m = 1\text{ kHz}$, 30% modulation

Parameter	Symbol	Conditions	min	typ	max	Unit
Quiescent current	I_{CCO-AM}	No input	10	20	33	mA
Detector output	$V_{O 1}$	23 dB μ , pin 14 output	25	50	100	mVrms
	$V_{O 2}$	80 dB μ , pin 14 output	75	125	190	mVrms
Signal to noise ratio	S/N 1	23 dB μ , pin 14 output	16	20		dB
	S/N 2	80 dB μ , pin 14 output	48	54		dB
Total harmonic distortion	THD-AM	80 dB μ , pin 14 output		0.3	1.0	%
		100 dB μ , pin 14 output		0.4	1.2	%
LED sensitivity	$V_{LED-SENS}$	The ANT input level at which the TU-LED turns on	18	28	38	dB μ
Local oscillator buffer output	V_{OSC-AM}	No input, pin 24 output	140	200		mVrms
Low band attenuation	LOW-CUT	Output when $f_m = 100\text{ Hz}$, referenced to 1 kHz	6.0	9.0	12.0	dB
IF count buffer output	$V_{IFBUFF-AM}$	80 dB μ , no modulation, pin 10 output	140	200	280	mVrms
Stereo IF output	$V_{ST-IF-AM}$	80 dB μ , no modulation, pin 7 output	8.0	17.0		mVrms

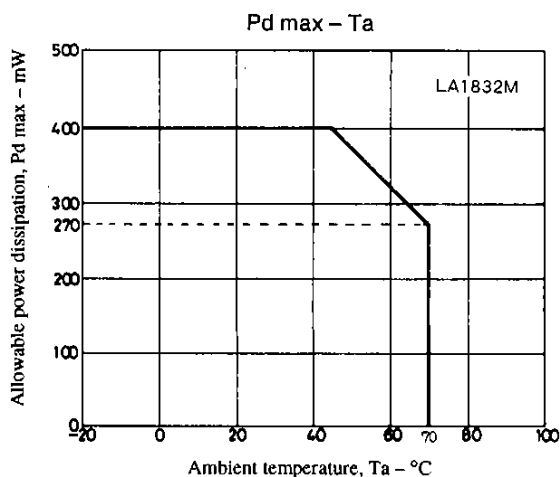
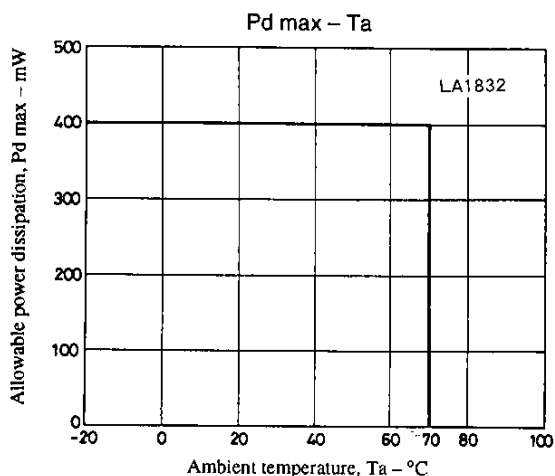

Equivalent Circuit Diagram

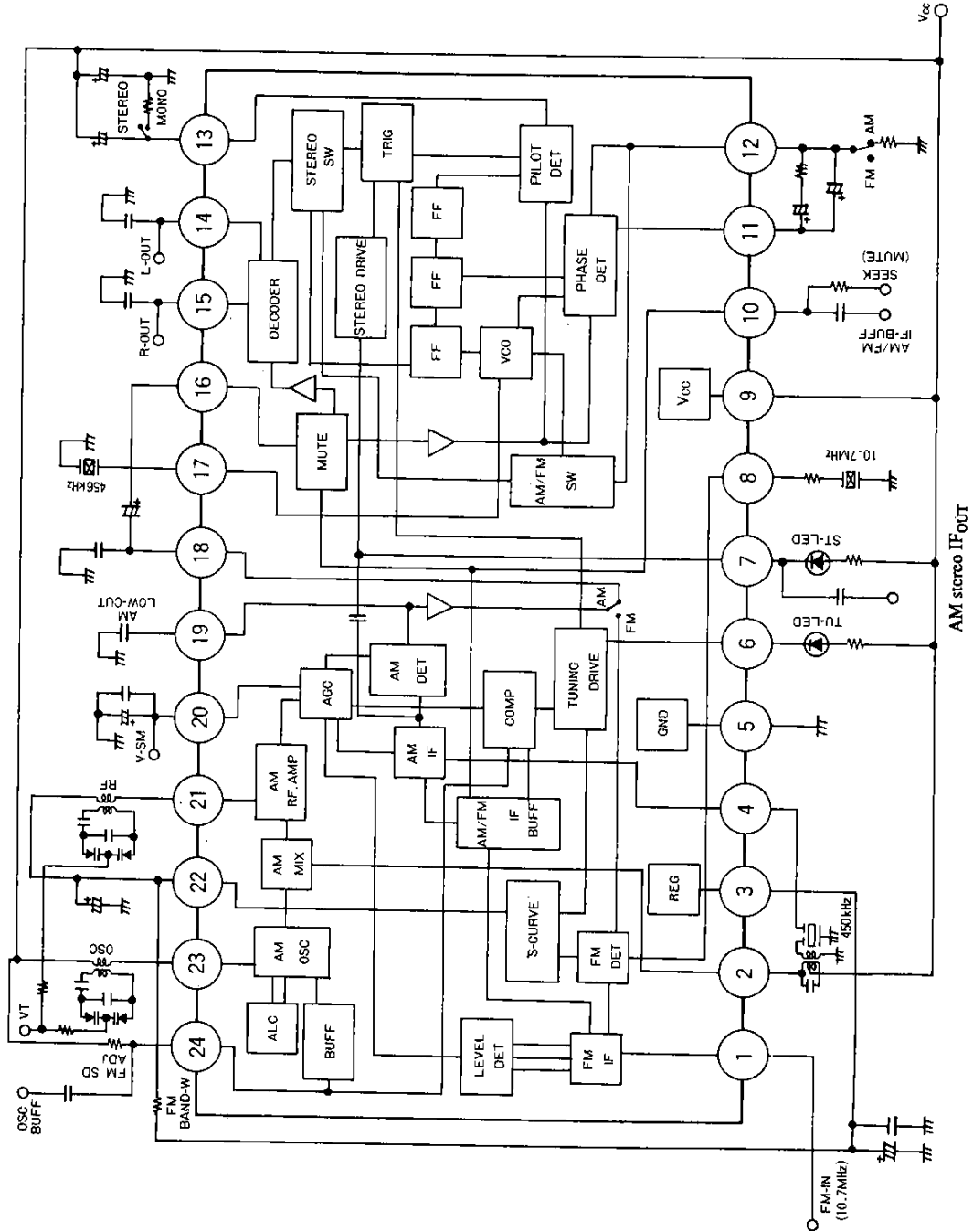

Test Circuit Diagram

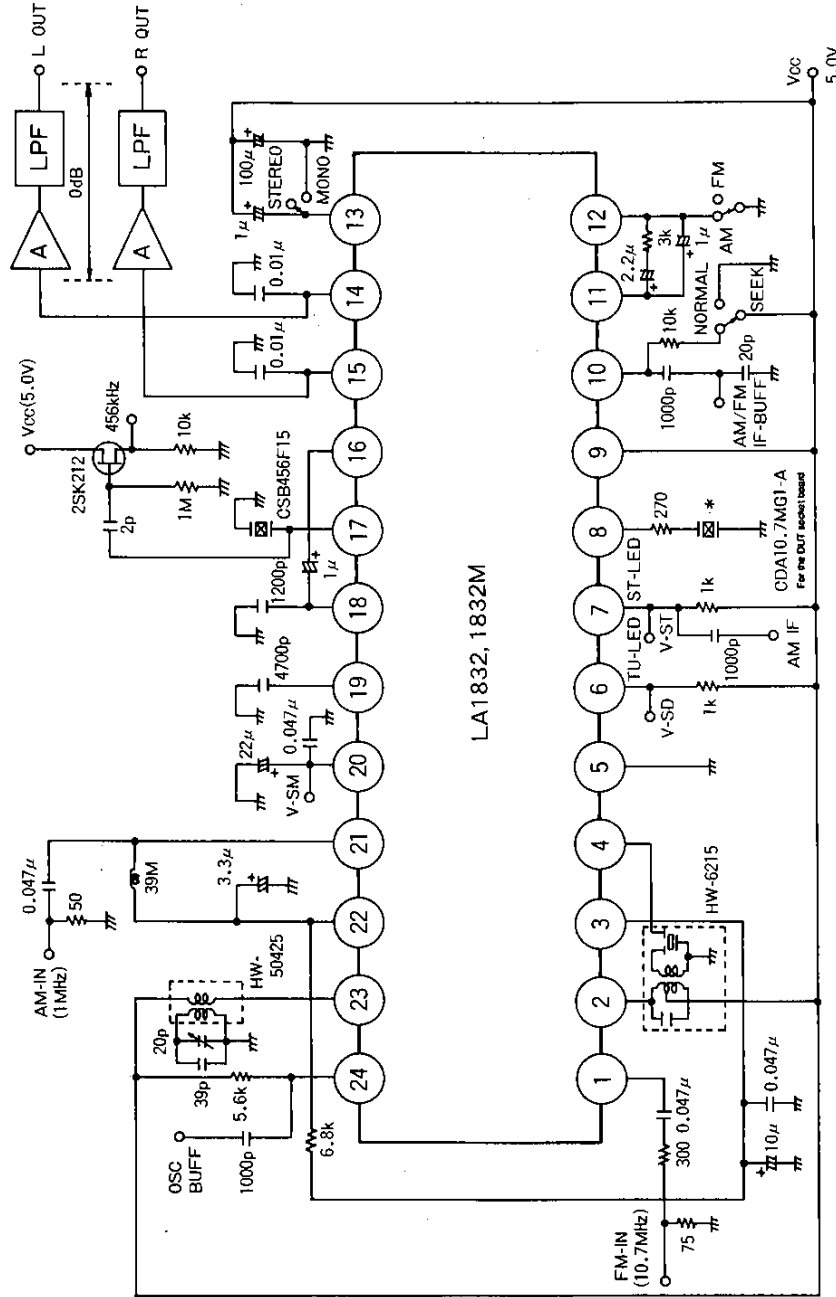

* Note: One of the discriminators listed below must be used when mounted in a set.

CDA10.7MG46-A (Murata Mfg. Co., Ltd.)
 FCD1070MA11SRL (TDK)

Unit (resistance: Ω, capacitance: F)

Pin Functions and Quiescent Voltages

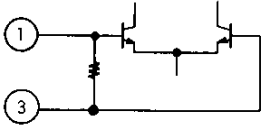
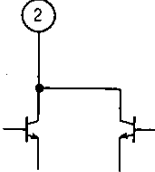
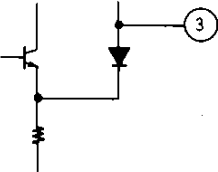
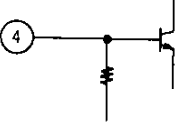
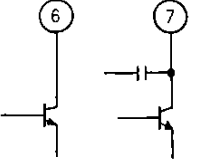
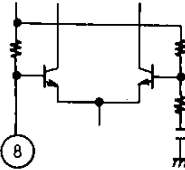
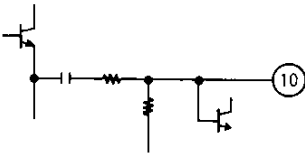
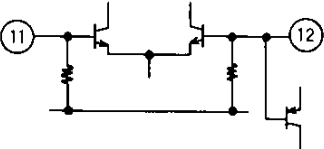
No.	Function	Pin voltage (V)	Equivalent circuit	Notes
1	FM IF input	2.1		Input impedance $r_i = 330 \Omega$
2	AM MIX output	5.0		Used for the MIX coil between pin 2 and pin 9 (the V_{CC} voltage)
3	REG	2.1		$V_{reg} = 2.1 V$
4	AM IF input	2.1		Input impedance $r_i = 2 k\Omega$
5	GND	0		
6	TU-LED	5.0		Active-"L" Open collector
7	ST-LED and IF output for AM stereo			
8	FM-DET	2.8 (FM) 3.4 (AM)		Recommended ceramic discriminator: CDA10.7MG46-A (Murata Mfg. Co., Ltd.) FCD1070MA11SRL (TDK)
9	V_{CC}	5.0		
10	AM/FM IF count output and control SW, and muteSW.	0		$V_{10} \leq 0.5 V$... Reception state (normal) $1.4 V \leq V_{10} \leq 2.2 V$... Muting on (mute) $V_{10} \geq 3.5 V$... Muting on, IF counter on (seek) Note: During seek, to improve SD speed the IF buffer will be output only when SD is in the on state.
11	Phase comparator filter pin, and AM/FM switch	Pin 11 3.8 (FM) 1.5 (AM)		AM mode is selected when over 200 μA flows from pin 12.
12		Pin 12 3.8 (FM) 0 (AM)		

Continued on next page

Continued from preceding page

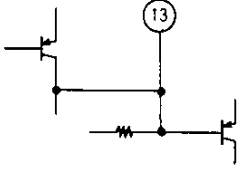
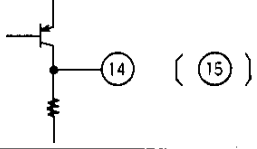
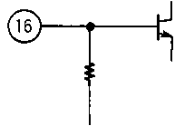
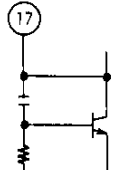
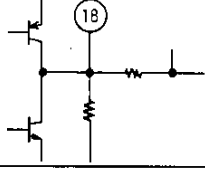
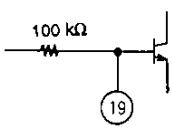
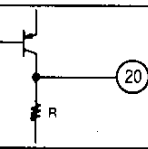
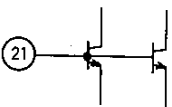
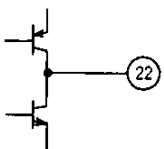
No.	Function	Pin voltage (V)	Equivalent circuit	Notes
13	Pilot detector filter pin, forced mono, VCO stop	3.5		Mode forced to mono when over 50 μ A flows from this pin The VCO stops at currents over 200 μ A
14 15	Left output Right output	1.2		Output impedance $r_o = 5 \text{ k}\Omega$
16	MPX input	2.1		Input impedance $r_i = 20 \text{ k}\Omega$
17	MPX VCO	2.4 (FM) 0 (AM)		Recommended ceramic oscillator: CSB456F15 (Murata Mfg. Co., Ltd)
18	AM/FM demodulator output	2.0 (FM) 0.9 (AM)		Output impedance FM: $r_o = 2.3 \text{ k}\Omega$ AM: $r_o = 10 \text{ k}\Omega$
19	AM LOW CUT	0 (FM) 1.9 (AM)		The low-band frequency characteristics are changed by an external capacitor connected to pin 19
20	S-meter, AM AGC	0.2 (FM) 0.9 (AM)		Built-in load resistance: $R = 13.9 \text{ k}\Omega$ An external capacitor connected to pin 20 determines the seek time SD response speed.
21	AM RF-IN	2.9 (FM) 2.1 (AM)		Pin 21 is used at the same potential as pin 22 (the AFC voltage).
22	AFC	2.9 (FM) 2.1 (AM)		The FM-SD bandwidth can be changed with an external resistor connected between pin 22 and pin 3 (Reg voltage). Note: A setting of 180 kHz or higher is recommended for the FM-SD bandwidth.

Continued on next page

Continued from preceding page

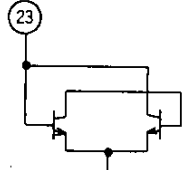
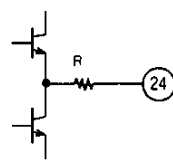
No.	Function	Pin voltage (V)	Equivalent circuit	Notes
23	OSC	5.0		An oscillator coil is used between pin 23 and pin 9 (the V _{CC} voltage). Note: An oscillator coil with an impedance of 5 kΩ or over (secondary side) should be used.
24	OSC buffer, FM SD adj.	3.6		The FM SD sensitivity can be changed with an external resistor connected to pin 24. R = 200 Ω Note: A resistor of 3.3 kΩ or over should be used for the pin 24 external resistor.

Coil Specifications

AM ANT BLOCK

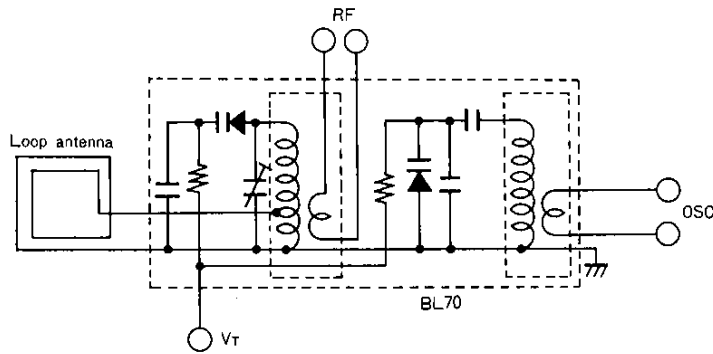

Loop antenna

- LA300 (Kohringiken, Ltd.)

Loop antenna matching coil

- KL-412 (Kohringiken, Ltd.) (for use with the SVC321)
- KO-387 (Kohringiken, Ltd.) (for SVC321 use)

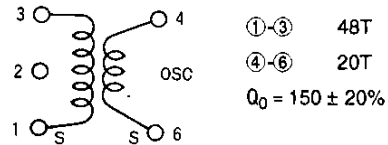
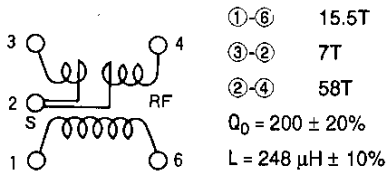

Continued on next page

- AM OSC (for DUT use)
HW-50425 (Mitsumi Electric Co., Ltd.)

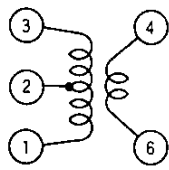

③-② 2T
④-⑥ 9T
②-① 86T
 $Q_0 \geq 80$
 $L = 270 \mu\text{H}$

- IFT
YD-1073-1 (Mitsumi Electric Co., Ltd.)

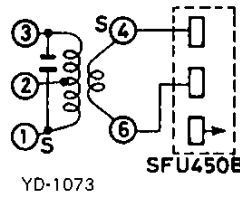

①-② 58T
④-⑥ 7T
②-③ 94T
 $f_0 = 450 \text{ kHz}$
 $Q_0 = 110$
180 pF internal
SFU 450B

- IFT (for DUT use)
HW-6215 (Mitsumi Electric Co., Ltd.)

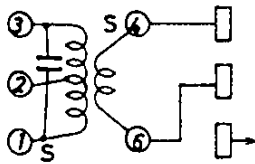

HW-6194
SFU-450B
①-② 94T
④-⑥ 7T
②-③ 58T
180 p

- IFT
PCFAZ-043 (TOKO ELECTRIC CO.)

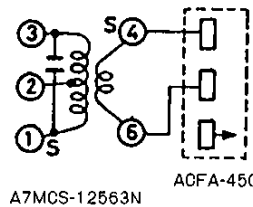

①-② 58T
④-⑥ 7T
②-③ 94T
 $f_0 = 450 \text{ kHz}$
 $Q_0 = 110$
180 pF internal
SFU 450B

- FM DET
7KL-7252 (TOKO ELECTRIC CO.)

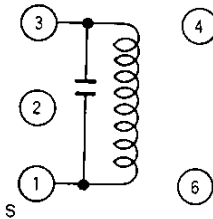

①-③ 15T
 $f_0 = 10.7 \text{ MHz}$
 $Q_0 = 85 \pm 20\%$
120 pF internal

- FM detector coil usage characteristics

Characteristic Item	Discriminator	Coil
Demodulator output	410 mV	300 mV
S/R ratio	76.5dB	74 dB
LED on bandwidth	160 kHz	220 kHz
ST on level	3.0%	4.2%

- Application circuit using an FM detector coil

DET PIN

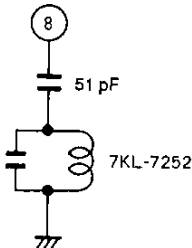

LA1832, 1832M

The LA1832 differs from the LA1831 in that functions have been added and the characteristics have been improved as follows.

1. SD time constant switching circuit added

AM AGC voltage rise characteristics
V10 = 0 V (normal)

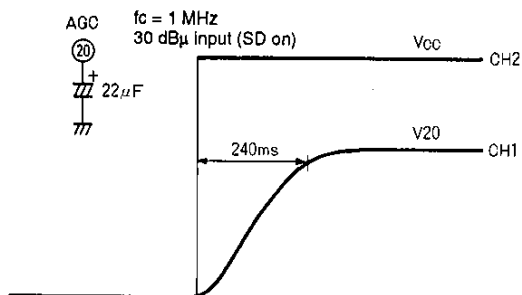

AM AGC voltage rise characteristics
V10 = 5.0 V (seek mode)

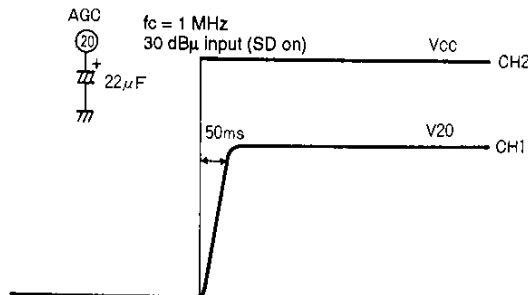

2. Improved distortion waviness and Fo drift with respect to the FM input level

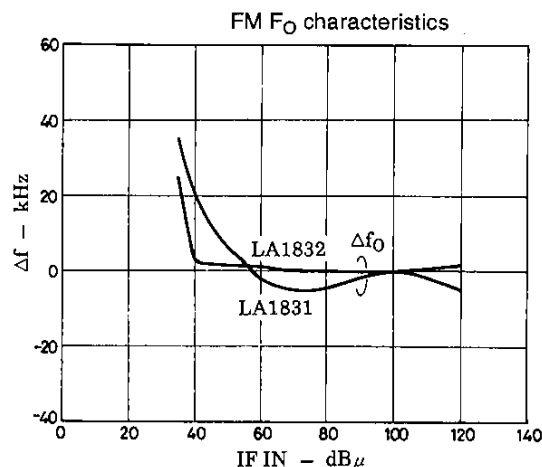
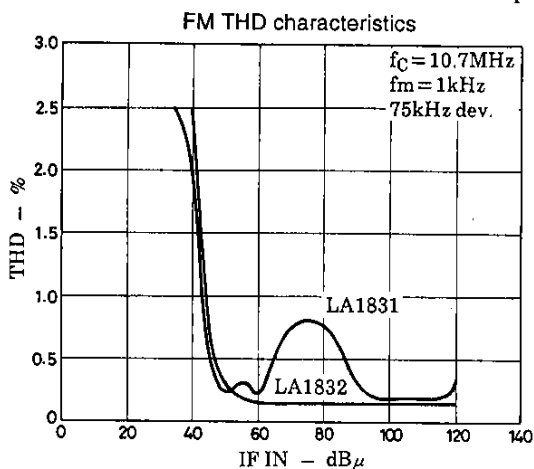

3. Changes in the FM SD on level

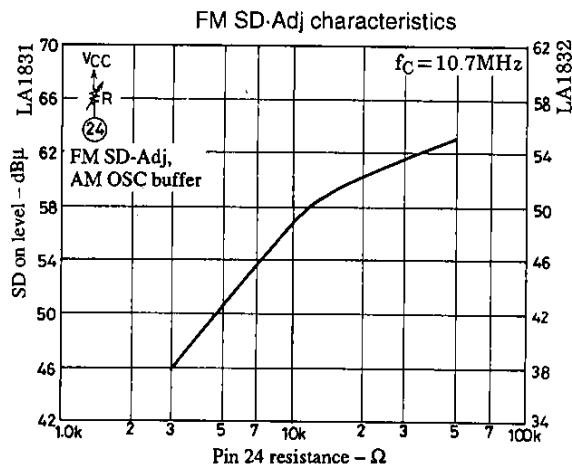
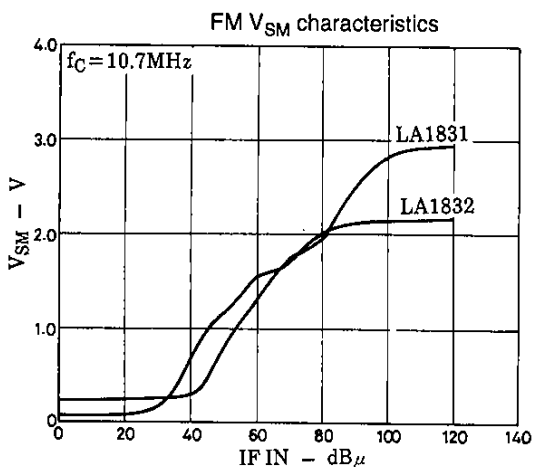

4. Improved FM S/N ratio and AMR

	S/N	AMR (for a 90 dBµ level)
LA1832	76.5 dB	55 dB
LA1831	75 dB	40 dB

5. Improved mute setting voltage range (to handle AM stereo)

It is now possible to create a muting only condition by setting the pin 10 supply voltage to $1.8 \text{ V} \pm 0.4 \text{ V}$.

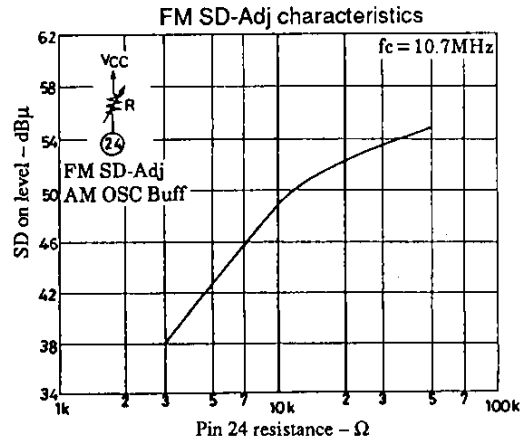
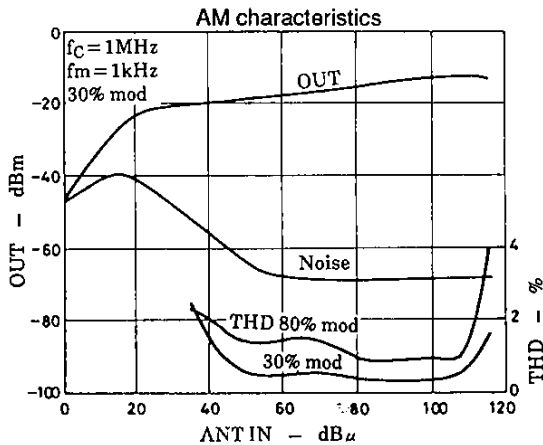
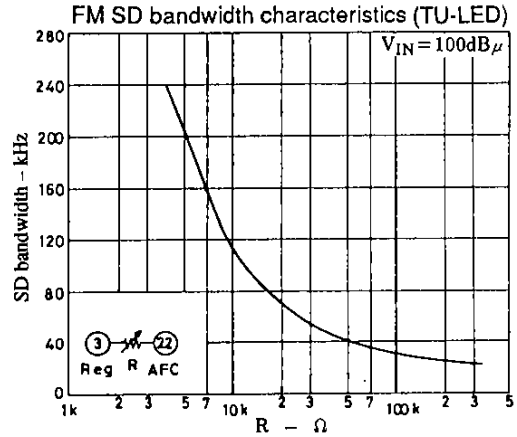
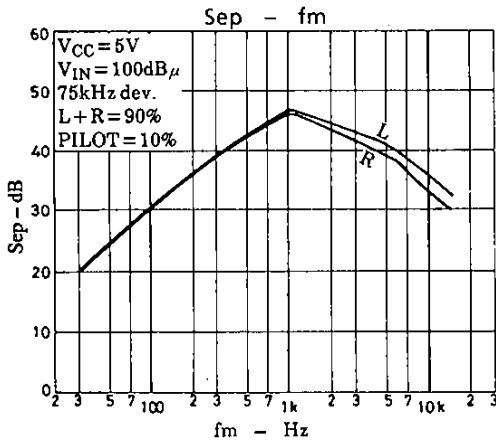
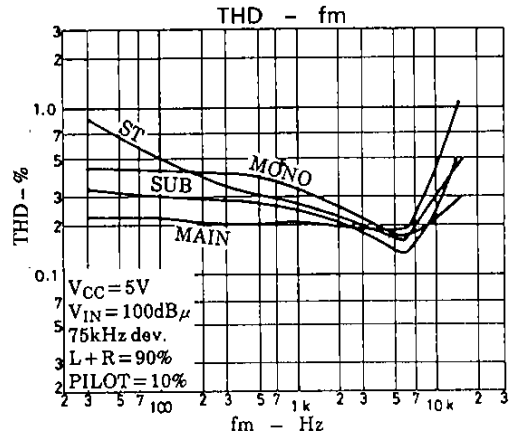
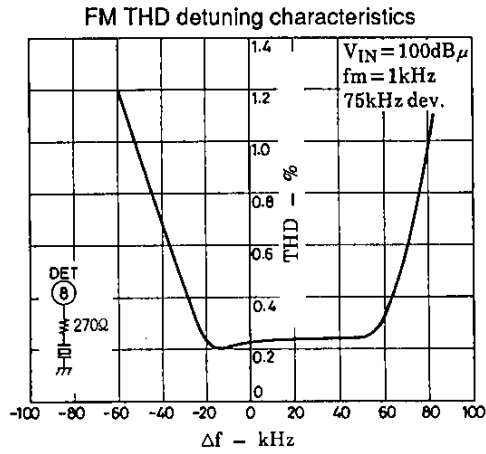
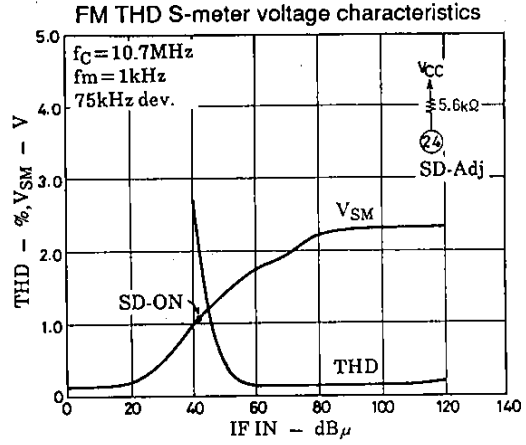
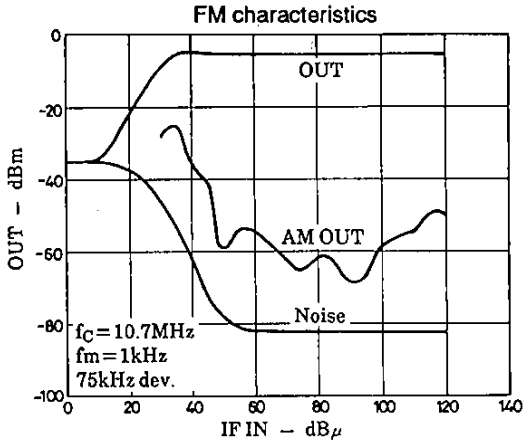

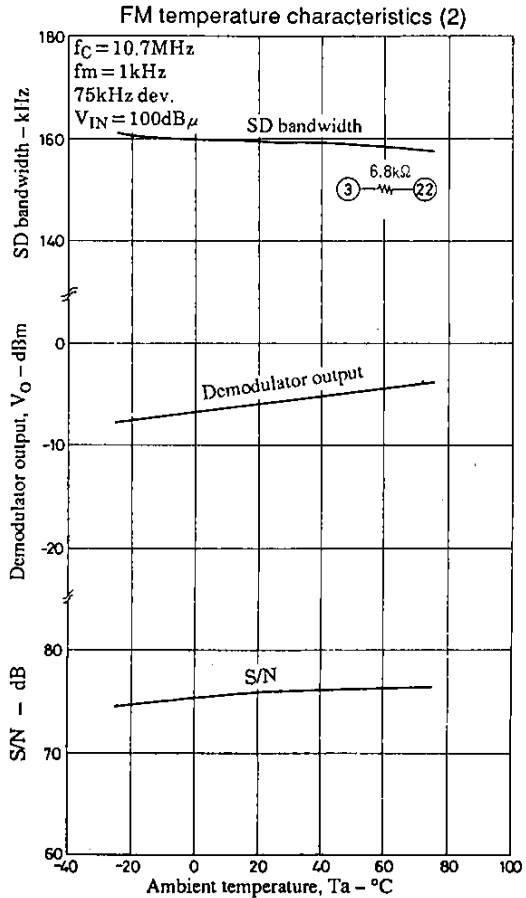
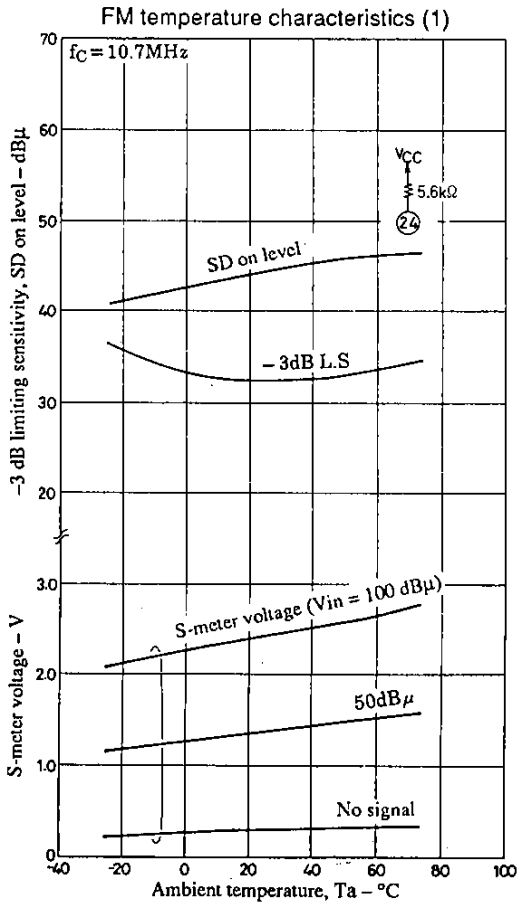
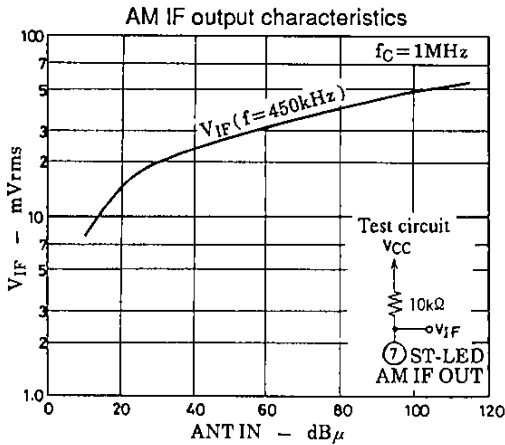
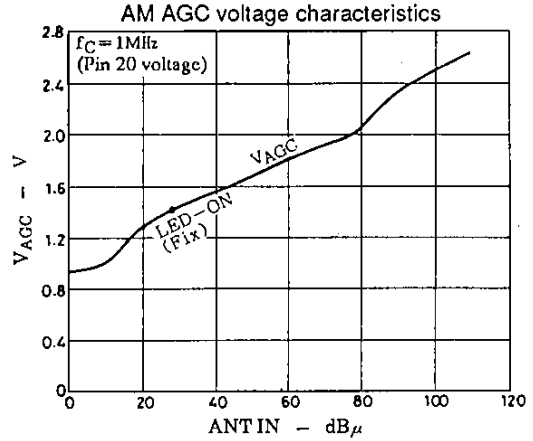
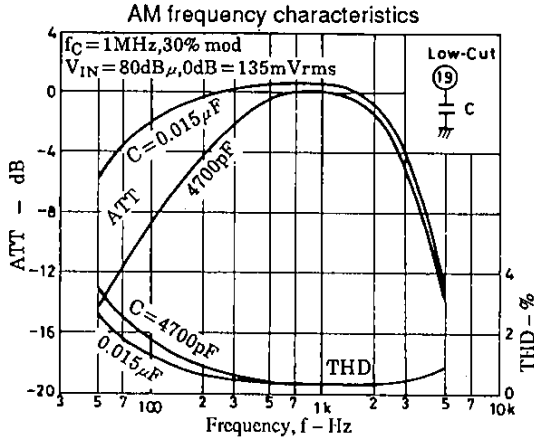

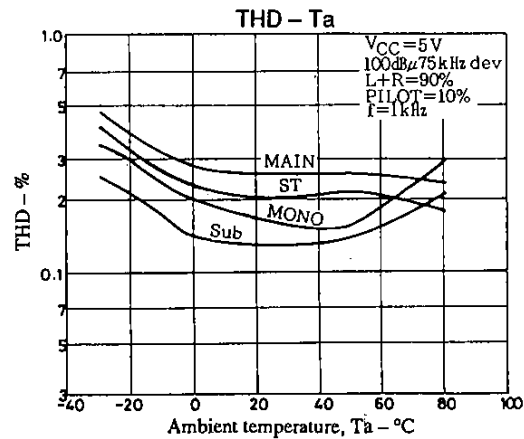
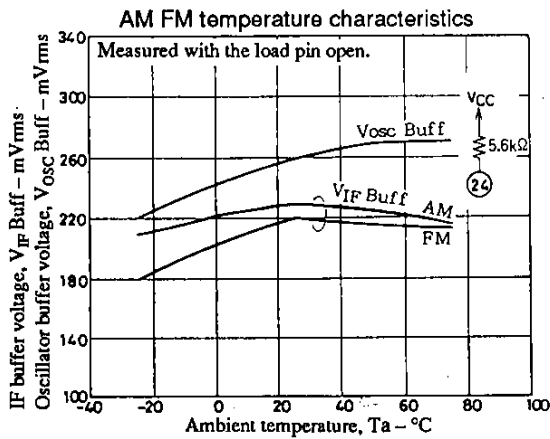
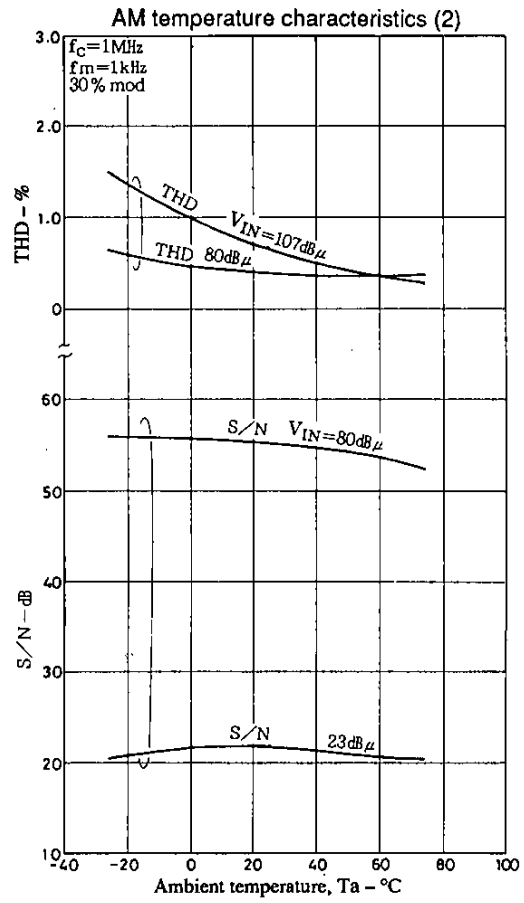
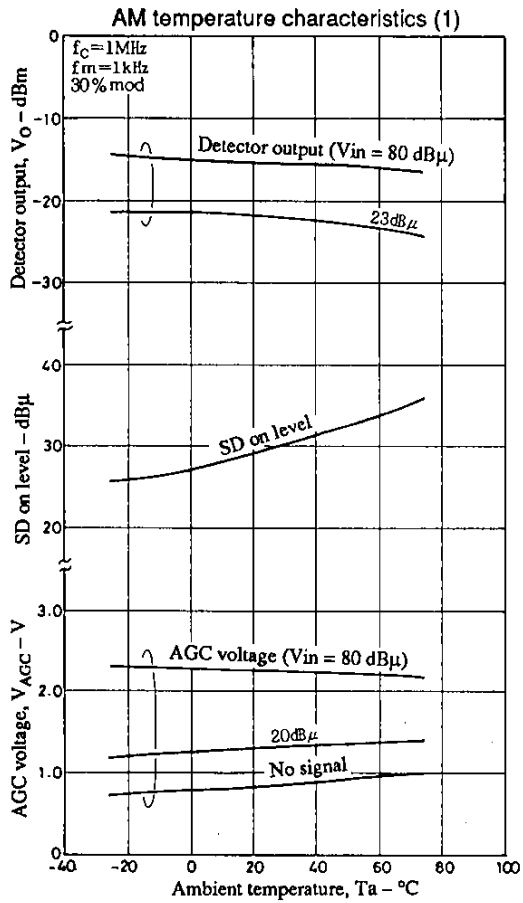
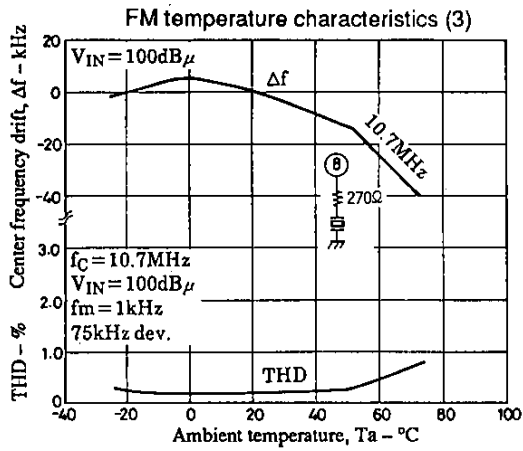

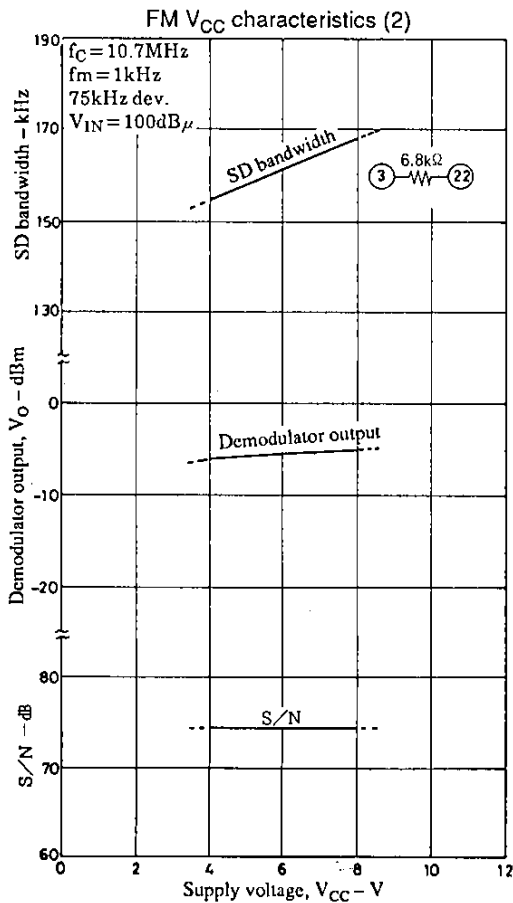
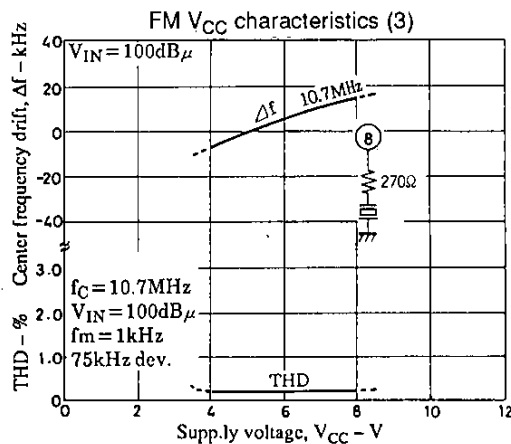
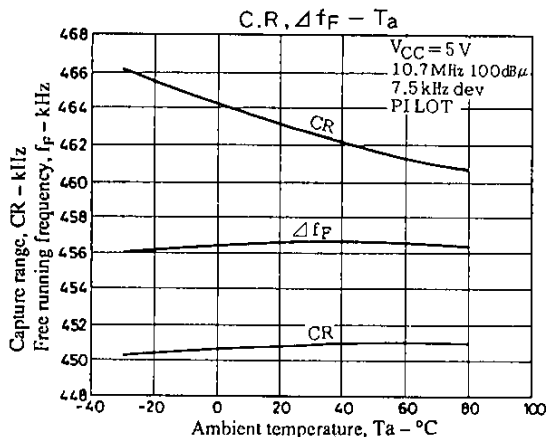
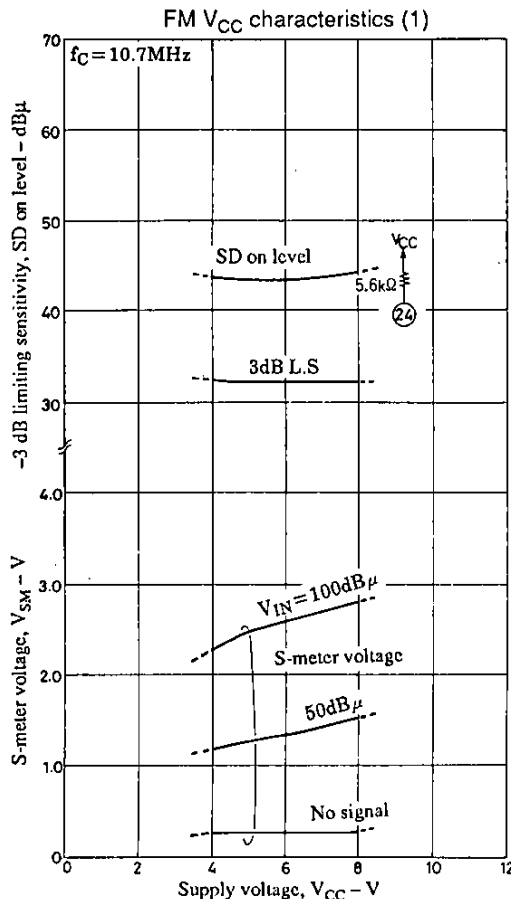
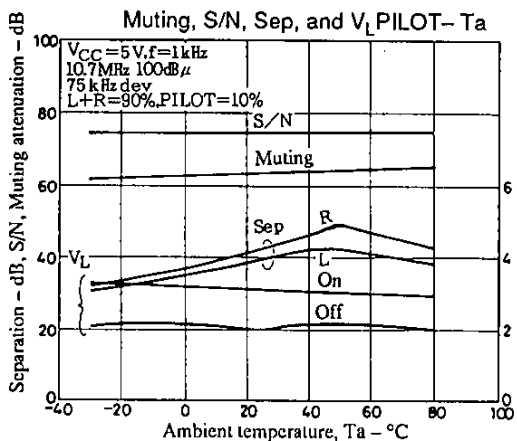

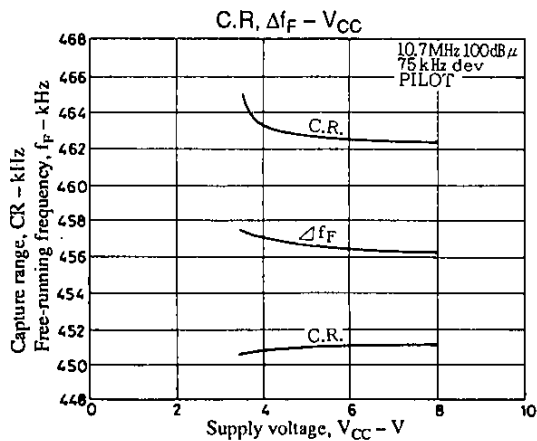
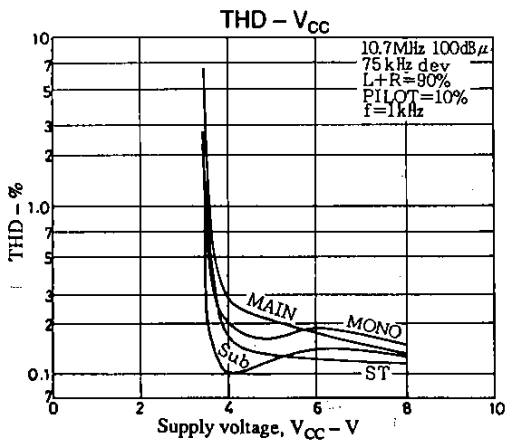
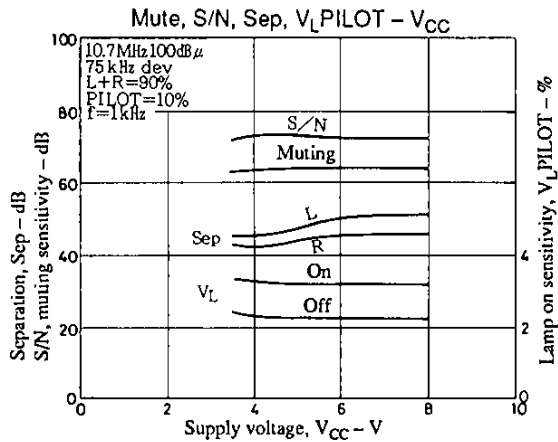
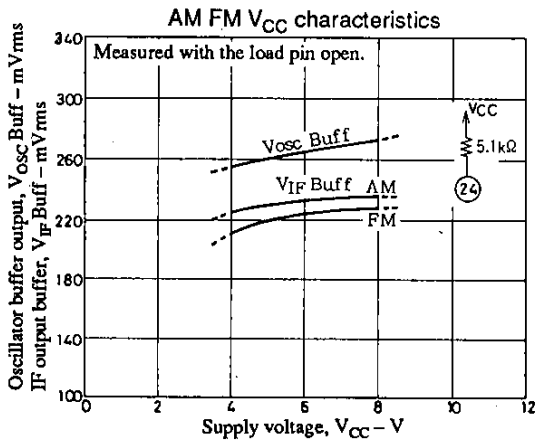
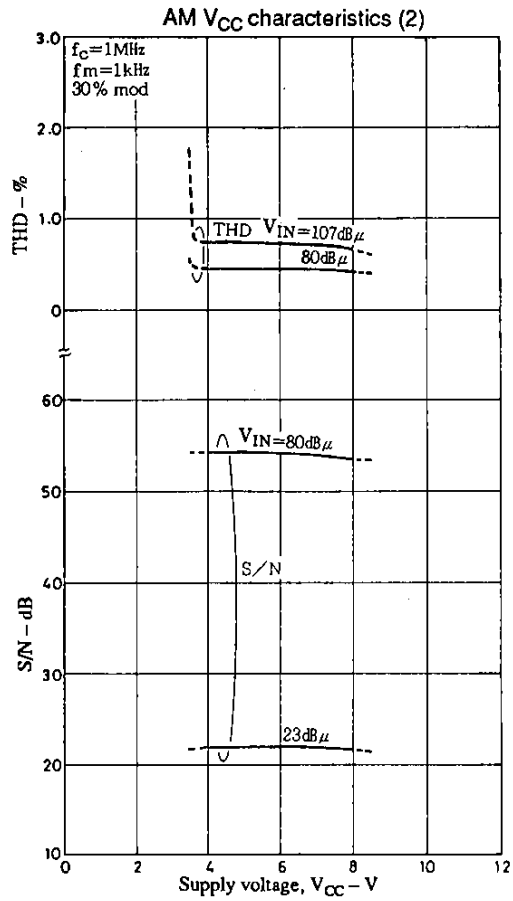
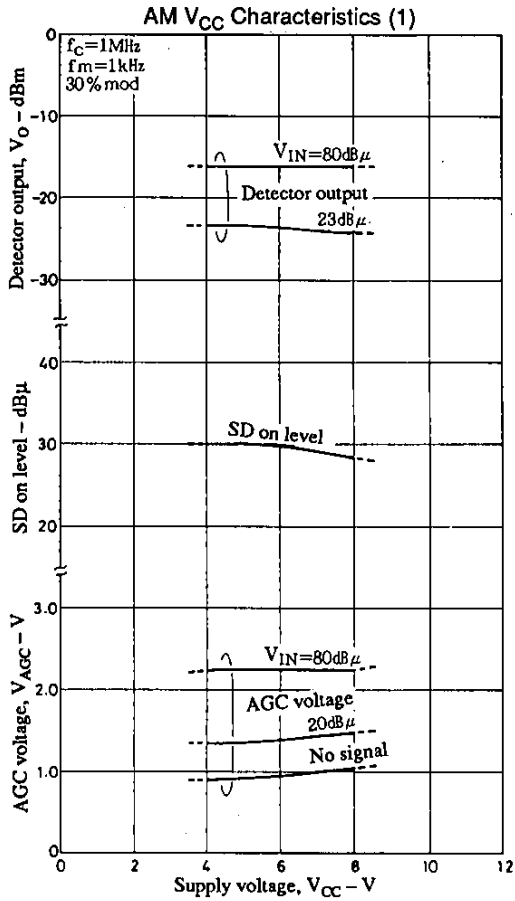

- No products described or contained herein are intended for use in surgical implants, life-support systems, aerospace equipment, nuclear power control systems, vehicles, disaster/crime-prevention equipment and the like, the failure of which may directly or indirectly cause injury, death or property loss.
- Anyone purchasing any products described or contained herein for an above-mentioned use shall:
 - ① Accept full responsibility and indemnify and defend SANYO ELECTRIC CO., LTD., its affiliates, subsidiaries and distributors and all their officers and employees, jointly and severally, against any and all claims and litigation and all damages, cost and expenses associated with such use:
 - ② Not impose any responsibility for any fault or negligence which may be cited in any such claim or litigation on SANYO ELECTRIC CO., LTD., its affiliates, subsidiaries and distributors or any of their officers and employees jointly or severally.
- Information (including circuit diagrams and circuit parameters) herein is for example only; it is not guaranteed for volume production. SANYO believes information herein is accurate and reliable, but no guarantees are made or implied regarding its use or any infringements of intellectual property rights or other rights of third parties.