

# IR2431/IR2432/IR2433 12-Dot LED Display Driver

## ■ Description

The IR2431/IR2432/IR2433 is suitable for driving 12 LED level meters.

The IR2433 is cascadable for 144 dots of bar graphic display.

## ■ Features

1. LED current can be set by an external resistor
2. IR2431 is a log-scale driver  
IR2432 is a VU meter scale driver  
IR2433 is a linear-scale driver
3. Cascaded connection is possible for IR2433
4. 22-pin dual-in-line package

## ■ Pin Connections

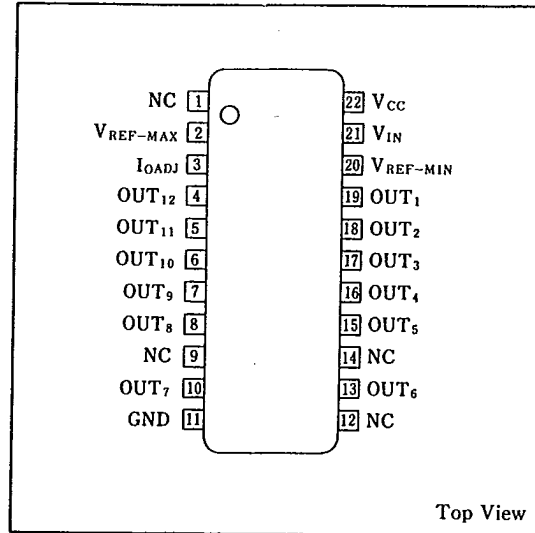

## ■ Block Diagram

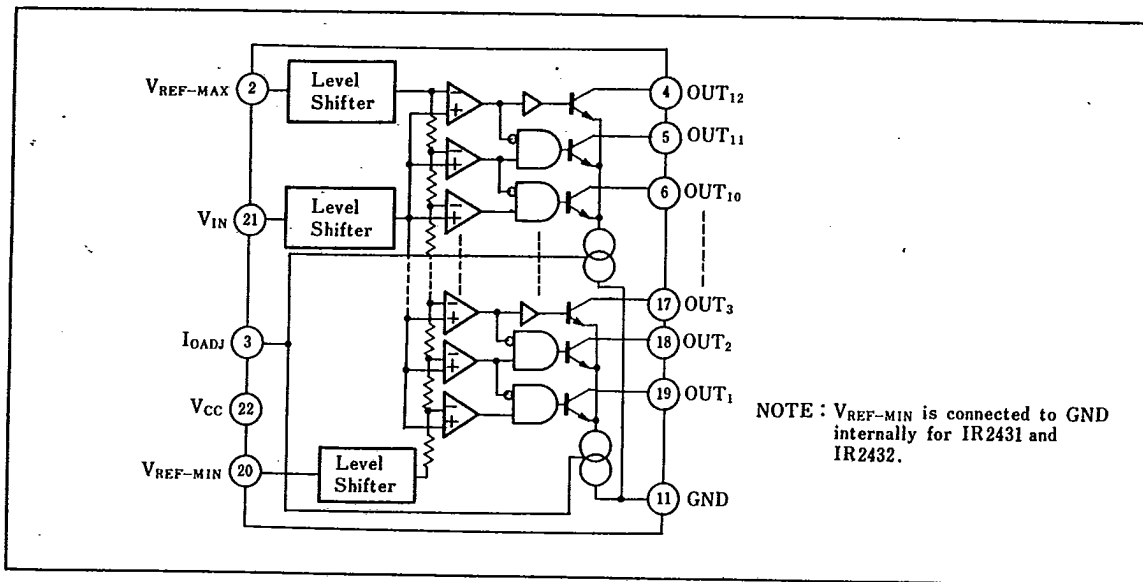

12-Dot LED Display Driver

IR2431/IR2432/IR2433

**Absolute Maximum Ratings**

Parameter	Symbol	Condition	Rating	Unit
Supply voltage	V <sub>CC</sub>		18	V
Input voltage	V <sub>IN</sub>	V <sub>CC</sub> < 10V	10	V
Reference voltage	V <sub>REF-MAX</sub>	V <sub>CC</sub> < 10V	10	V
	V <sub>REF-MIN</sub>		10	
Power dissipation	P <sub>D</sub>	T <sub>a</sub> ≤ 25°C	1,000	mW
P <sub>D</sub> derating ratio	ΔP <sub>D</sub> /°C	T <sub>a</sub> > 25°C	10	mW/°C
Operating temperature	T <sub>opr</sub>		-20 ~ +75	°C
Storage temperature	T <sub>stg</sub>		-25 ~ +125	°C

**Electrical Characteristics**

(V<sub>CC</sub> = 12V, T<sub>a</sub> = 25°C)

Parameter	Symbol	Condition	MIN.	TYP.	MAX.	Unit	
Operating supply voltage	V <sub>CC</sub>		8	12	16	V	
Supply current	I <sub>CC</sub>			4	6	mA	
Operating reference voltage	V <sub>REF-MAX</sub>	V <sub>CC</sub> - V <sub>REF-MAX</sub> ≥ 2.5V	IR2431	5.5		6.0	V
			IR2432	0.6	0.8	1.6	
		V <sub>CC</sub> - V <sub>REF-MAX</sub> ≥ 2.5V	IR2433	0.5		6.0	
Input current	I <sub>IN</sub>	Take the current flowing into IC for positive.	-1			μA	
	I <sub>REF-MAX</sub>	Applies to IR2433	-1				
	I <sub>REF-MIN</sub>				1		
Output current	I <sub>OUT</sub>	V <sub>IN</sub> = 6.5V, R <sub>O</sub> = 96kΩ	7.5	10	12.5	mA	
Output leakage current	I <sub>OL</sub>				10	μA	

**Description of Operation**

With V<sub>REF-MAX</sub> and V<sub>REF-MIN</sub> (IR2431 and IR2432 are connected inside to the GND) given, the reference voltage is 12-divided by the resistance ratio. This is compared with the V<sub>IN</sub> in each of the comparator circuits to cause the output "High" or "Low" in the AND gate to turn the corresponding transistor on and the LED will glow.

**Basic Connection Diagram**

(Example GL112R9 Series)

Apply the power supply voltage across the V<sub>CC</sub>-GND and apply to V<sub>REF-MAX</sub> and V<sub>REF-MIN</sub> their reference voltage (IR2431, IR2432 and V<sub>REF-MIN</sub> are connected inside to the GND). Apply the input voltage to V<sub>IN</sub>. The current to flow through the LED, I<sub>LED</sub> can be altered by varying R<sub>O</sub>.

The current I<sub>LED</sub> can be given by the following equation.

$$I_{LED} = 90 \times \frac{V_{CC} - 1.3}{R_O + 1} \text{ (mA)}$$

V<sub>CC</sub>: V, R<sub>O</sub>: kΩ

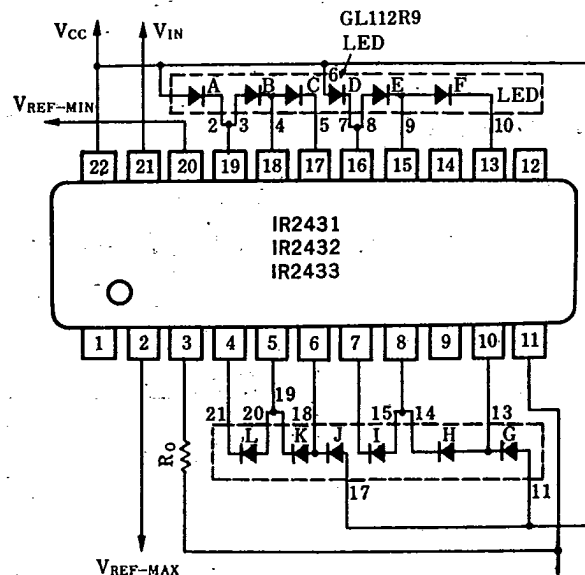

12-Dot LED Display Driver

IR2431/IR2432/IR2433

■ Comparator Level  
IR2431, IR2432

(Unit: dB)

Model \ LED	A	B	C	D	E	F	G	H	I	J	K	L
IR2431	-44	-40	-36	-32	-28	-24	-20	-16	-12	-8	-4	0
IR2432	-20	-15	-10	-7	-4	-2	-1	0	+1	+2	+3	+6

IR2433

As  $V_{IN}$  is increased from 0V, the bar type LEDs light up in order. The input level at which the n-th LED lights up can be nearly represented by the following formula.

$$V_n = n \frac{V_{REF-MAX} - V_{REF-MIN}}{12} + V_{REF-MIN}$$

■ Example of IR2433 Circuit Application

(1) 2-chip cascaded

$V_{CC}$ ,  $V_{IN}$ ,  $V_{REF-MIN}$ ,  $V_{REF-MAX}$  and BND are connected as shown in the right Fig.

By selecting  $R_1 = R_2$ ,  $V_{REF-MAX} - V_{REF-MIN}$  can be divided into 24 equal voltage.

Also, the desired division is possible provided that  $R_1$  and  $R_2$  satisfy the following formula.

$$\frac{V_{REF-MAX} - V_{REF-MIN}}{R_1 + R_2} > 100 \text{ } (\mu A)$$

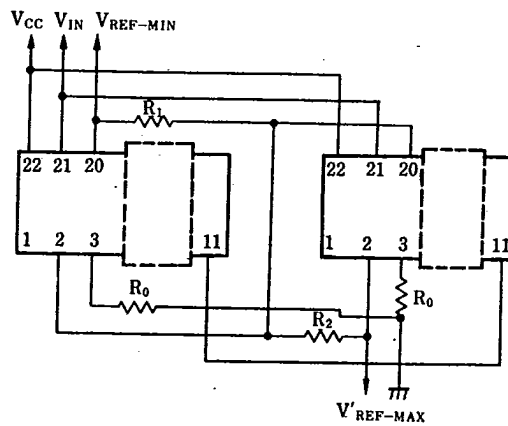

(2) 3~12-chip cascaded

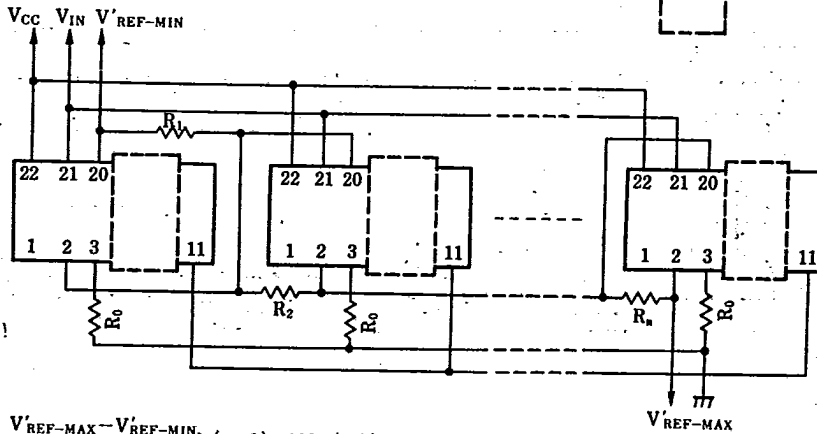

$$\frac{V_{REF-MAX} - V_{REF-MIN}}{\sum R_i} > (n-1) \times 100 \text{ } (\mu A)$$

(i=1,2,...,n)

For the connection, refer to the typical connection diagram.

