

TOSHIBA Bipolar Linear Integrated Circuit Silicon Monolithic

TA2149BN, TA2149BFN

3 V AM/FM 1 Chip Tuner IC (for Digital Tuning System)

TA2149BN, TA2149BFN are AM/FM 1 chip tuner ICs, which are designed for portable Radios and 3 V Head phone Radios.

This is suitable for Digital Tuning System Applications. FM Local Oscillation Voltage is set up low relatively, for NEW FCC.

Functions

- For NEW FCC.
- Suitable for combination with Digital Tuning System which is included IF Counter.
 - Adjustable for IF count output sensitivity by external resistance of pin 17 (FM only).
- One terminal type AM/FM IF count output for IF counter of Digital Tuning System.
 - FM: 1.3375 MHz (1/8 dividing)
 - AM: 450 kHz
- Built-in Mute Circuit for IF count output.
- For adopting ceramic Discriminator, it is not necessary to adjust the FM Quad Detector Circuit.
- Built-in FM MPX VCO circuit.
- Built-in one terminal type AM/FM Local Oscillator Buffer Output for Digital Tuning System Applications.
 - Built-in 1/16 Pre-scaler for FM Local OSC Buffer.
- Built-in AM Low cut circuit.
- Low supply current. ($V_{CC} = 3\text{ V}$, $T_a = 25^\circ\text{C}$)
 - $I_{CCq}(\text{FM}) = 13\text{ mA (Typ.)}$
 - $I_{CCq}(\text{AM}) = 8.5\text{ mA (Typ.)}$
- Operating Supply voltage range: $V_{CC} = 1.8\sim 7\text{ V}$ ($T_a = 25^\circ\text{C}$)

Note 1: Handle with care to prevent devices from deteriorations by static electricity.

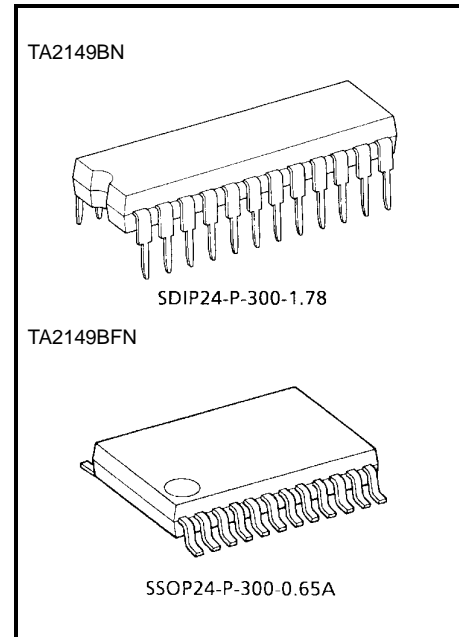

Weight
 SDIP24-P-300-1.78: 1.2 g (Typ.)
 SSOP24-P-300-0.65A: 0.14 g (Typ.)

Block Diagram

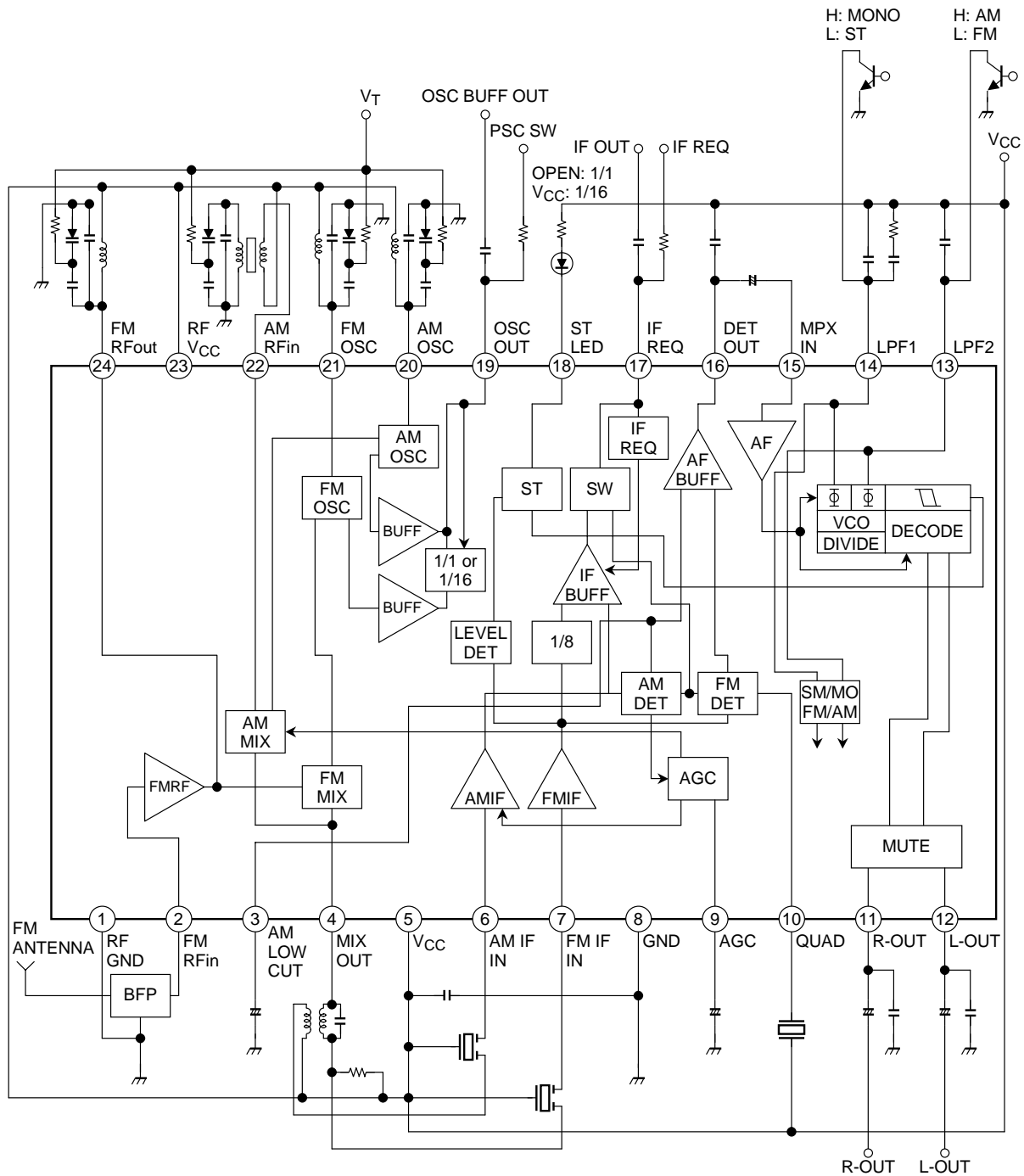

Explanation of Terminals

(Terminal Voltage: Typical terminal voltage at no signal with test circuit, $V_{CC} = 3\text{ V}$, $T_a = 25^\circ\text{C}$)

PIN No.	Characteristic	Internal Circuit	Terminal Voltage (Typ.) (V)	
			AM	FM
1	RF GND (GND for FM RF stage)	—	0	0
2	FM-RFin		0	0.8
3	AM LOW CUT		1.0	—
4	MIX OUT		3.0	3.0
5	V_{CC} (V_{CC} for AM, FM IF, MPX)	—	3.0	3.0
6	AM IF IN		2.3	2.5

PIN No.	Characteristic	Internal Circuit	Terminal Voltage (Typ.) (V)	
			AM	FM
7	FM IF IN		3.0	3.0
8	GND (GND for AM, FM IF, MPX)	—	0	0
9	AGC		0	0
10	QUAD		2.5	2.2
11 12	R-OUT L-OUT		1.2	1.2

PIN No.	Characteristic	Internal Circuit	Terminal Voltage (Typ.) (V)	
			AM	FM
13	<p>LPF2</p> <ul style="list-style-type: none"> • LPF terminal for phase detector • Bias terminal AM/FM SW circuit <p>$V_{13} = \text{GND} \rightarrow \text{AM}$ $V_{13} = \text{OPEN} \rightarrow \text{FM}$</p>		0	2.2
14	<p>LPF1</p> <ul style="list-style-type: none"> • LPF terminal for synchronous detector • VCO stop terminal <p>$V_{14} = \text{GND} \rightarrow \text{VCO STOP}$</p>		0.7	2.4
15	MPX IN		0.7	0.7
16	DET OUT	<p>(a) LOW \rightarrow FM, HIGH \rightarrow AM (b) LOW \rightarrow AM, HIGH \rightarrow FM</p>	1.0	0.9

PIN No.	Characteristic	Internal Circuit	Terminal Voltage (Typ.) (V)	
			AM	FM
17	IF REQ		—	—
18	ST LED		—	—
19	OSC OUT		2.8	2.7
20	AM OSC		3.0	3.0
21	FM OSC		3.0	3.0

PIN No.	Characteristic	Internal Circuit	Terminal Voltage (Typ.) (V)	
			AM	FM
22	AM RFin		3.0	3.0
23	RF V _{CC} (V _{CC} for FM RF stage)	—	3.0	3.0
24	FM RFout	cf. pin 1	3.0	3.0

Application Note

1. AM Low-Cut Circuit

- The AM Low-Cut action is carried out by the bypass of the high frequency component of the positive-feedback signal at the AF AMP stage. The external capacitor: C₃ by-pass this component.
- The cut-off frequency f_L is determined by the internal resistance 22 kΩ (Typ.) and the external capacitor C₃ as following;

$$f_L = \frac{1}{2 \times \pi \times 22 \times 10^3 \times C_3} \text{ (Hz)}$$

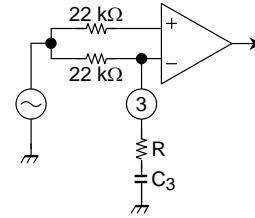

- In the case of the AM Low-Cut function is not needed, set up the value of C₃ over 1 μF. In the condition of C₃ ≥ 1 μF, the frequency characteristic has flat response at the low frequency.
- It is possible to reduce the recovered output level at AM mode, by additional resistance between the pin 3 and GND line.

2. FM Detection Circuit

For the FM detection circuit, detection coil is able to use instead of ceramic discriminator. Recommended circuit and recommended coil are as follows. (In this case, please take care that V_{in} (lim.) falls a little.)

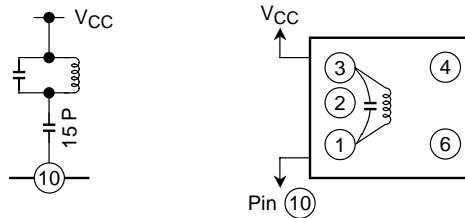

Test Frequency	Co (pF)	Qo	Turns				Wire (mmφ)	Reference
			1-2	2-3	1-3	4-6		
10.7 MHz	51	45	—	—	30	—	0.08UEW	Toko Co., Ltd. 600BEAS-10018Z

3. FM/AM switch and forced monaural switch.

- FM/AM switchover and stereo/forced monaural switchover are done by pin 13 and pin 14.
- FM/AM switch (pin 13)
V13: Low (Active Low, V_{th} = 0.2 V (Typ.), I_{th} 30 μA (Typ.) → AM
V13: OPEN → FM
- Stereo/forced monaural switch (pin 14)
V14: Low (Active Low, V_{th} = 0.2 V (Typ.), I_{th} 30 μA (Typ.) → Forced Monaural
V14: OPEN → Stereo

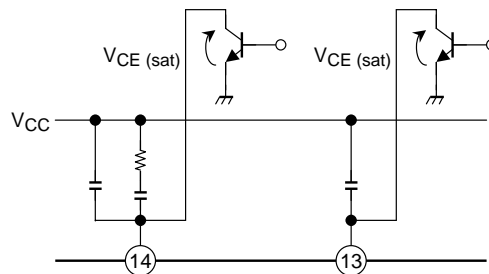

4. V_{CC} Line

This ICs have two voltage supply terminals, V_{CC} (for AM, FM IF, MPX stage) and RF V_{CC} (for FM RF stage). Set up the potential difference between V_{CC} and RF V_{CC} 0.4 V (typ.) or less, otherwise there is the case that this IC doesn't operate normally.

5. How to control the Divider of FM OSC.

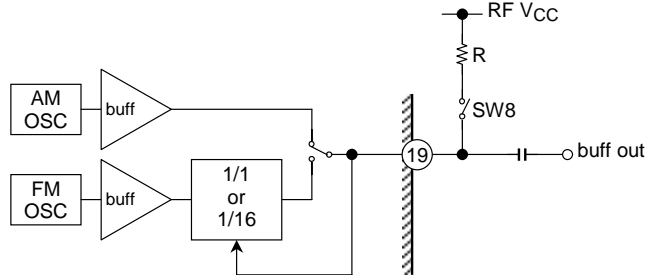

Divider of FM OSC ON/OFF switching is controlled by external pull-up resistor of pin 19. In case of Divider of FM OSC is used, it is necessary to set up the value of R under 470 Ω (typ.). When R is over 470 Ω, it is feared that Divider is not operating. (At this time, buffer output frequency is equal to FM OSC frequency.) Which ever Divider of FM OSC is used or not, AM OSC buffer frequency and output level is same.

Mode	SW8	Output Frequency	Output Level (Typ.)
FM	OPEN	1/1 FM OSC	35 mVrms
	ON	1/16 FM OSC	110 mVrms
AM	OPNE	1/1 FM OSC	75 mVrms
	ON		

6. How to adjust the IF Count Output Sensitivity

IF count output sensitivity can be adjusted by changing the value of external resistance at pin 17. This ICs have IF signal level detector in pin 9. When DC voltage of pin 9 is high than threshold, IF count output signal come out from the pin 17. And this threshold is controlled by value of external resistance at pin 19.

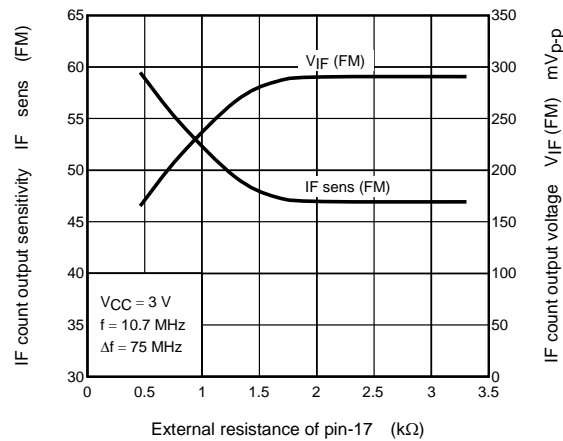

Maximum Ratings (Ta = 25°C)

Characteristics		Symbol	Rating	Unit
Supply voltage		V _{CC}	8	V
LED current		I _{LED}	10	mA
LED voltage		V _{LED}	8	V
Power dissipation	TA2149BN	P _D (Note 2)	1200	mW
	TA2149BFN		500	
Operating temperature		T _{opr}	-25~75	°C
Storage temperature		T _{stg}	-55~150	°C

Note 2: Derated above Ta = 25°C in the proportion of 9.6 mW/°C for TA2149BN of 4 mW/°C for TA2149BFN.

Electrical Characteristics (Unless otherwise specified, Ta = 25°C, V_{CC} = 3 V, F/E: f = 98 MHz, f_m = 1 kHz FM IF: f = 10.7 MHz, Δf = ±75 kHz, f_m = 1 kHz AM: f = 1 MHz, MOD = 30%, f_m = 1 kHz MPX: f_m = 1 kHz)

Characteristic		Symbol	Test Circuit	Test Condition	Min	Typ.	Max	Unit
Supply current		I _{CC} (FM)	—	V _{in} = 0, FM mode	—	13	16.5	mA
		I _{CC} (AM)	—	V _{in} = 0, AM mode	—	8.5	11.0	
F/E	Input limiting voltage	V _{in} (lim)	—	V _{in} = 60dBμV EMF, -3dB limiting	—	10	—	dBμV EMF
	Local OSC buffer output voltage 1	V _{OSC} (buff) FM1	—	f _{OSC} = 108.7 MHz	23	35	—	mVrms
	Local OSC buffer output voltage 2	V _{OSC} (buff) FM2	—	f _{OSC} = 6.79375 MHz SW8: ON	75	110	—	mVrms
FM IF	Input limiting voltage	V _{in} (lim) IF	—	V _{in} = 80dBμV EMF, -3dB limiting	37	42	47	dBμV EMF
	Recovered output voltage	V _{OD}	—	V _{in} = 80dBμV EMF	200	250	300	mVrms
	Signal to noise ratio	S/N	—	V _{in} = 80dBμV EMF	—	75	—	dB
	Total harmonic distortion	THD	—	V _{in} = 80dBμV EMF	—	0.3	—	%
	AM rejection ration	AMR	—	V _{in} = 80dBμV EMF	—	60	—	dB
	IF count output frequency	f _{IF} (FM)	—	V _{in} = 80dBμV EMF, SW7: ON	1.3373	1.3375	1.3377	MHz
	IF count output voltage	V _{IF} (FM)	—	V _{in} = 80dBμV EMF, SW7: ON	250	290	330	mV _{p-p}
IF count output sensitivity	IF sens (FM)	—	SW7: ON	42	47	52	dBμV EMF	
AM	Gain	G _V	—	V _{in} = 27dBμV EMF	20	38	70	mVrms
	Recovered output voltage	V _{OD}	—	V _{in} = 60dBμV EMF	60	85	108	mVrms
	Signal to noise ratio	S/N	—	V _{in} = 60dBμV EMF	—	41	—	dB
	Total harmonic distortion	THD	—	V _{in} = 60dBμV EMF	—	0.7	—	%
	Local OSC buffer output voltage	V _{OSC} (buff) AM	—	f _{OSC} = 1.45 MHz	55	75	—	mVrms
	IF count output voltage	V _{IF} (AM)	—	V _{in} = 60dBμV EMF, SW7: ON	250	290	350	mV _{p-p}
IF count output sensitivity	IF sens (AM)	—	SW7: ON	33	38	43	dBμV EMF	
Pin 17 output resistance		R ₁₇	—	FM mode	—	0.75	—	kΩ
			—	AM mode	—	15.5	—	

Characteristic		Symbol	Test Circuit	Test Condition	Min	Typ.	Max	Unit	
MPX	Input resistance	R_{IN}	—	—	—	55	—	k Ω	
	Output resistance	R_{OUT}	—	—	—	5	—	k Ω	
	Max. composite signal input voltage	$V_{in\ MAX}$ (Stereo)	—	L + R = 90%, P = 10%, SW3: LPF ON $f_m = 1\ kHz$, THD = 3%	—	700	—	mVrms	
	Separation	Sep.	—	L + R = 180 mVrms, P = 20 mVrms SW3: LPF ON	$f_m = 100\ Hz$	—	45	—	dB
					$f_m = 1\ kHz$	35	45	—	
					$f_m = 10\ kHz$	—	45	—	
	Total harmonic distortion	Monaural	THD (Monaural)	—	$V_{in} = 200\ mVrms$	—	0.3	—	%
		Stereo	THD (Stereo)	—	L+R = 180 mVrms, P = 20 mVrms, SW3: LPF ON	—	0.3	—	
	Voltage gain		G_V	—	$V_{in} = 200\ mVrms$	-2.7	-1.2	0.2	dB
	Channel balance		C.B.	—	$V_{in} = 200\ mVrms$	-1.5	0	1.5	dB
	Stereo LED sensitivity	ON	V_L (ON)	—	Pilot input (19 kHz)	—	10	14	mVrms
OFF		V_L (OFF)	—	5		8	—		
Stereo LED hysteresis		V_H	—	To LED turn off from LED turn on	—	2	—	mVrms	
Capture range		C.R.	—	P = 15 mVrms	—	± 8	—	%	
Signal noise ratio		S/N	—	$V_{in} = 200\ mVrms$	—	80	—	dB	
Muting attenuation		MUTE	—	$V_{in} = 200\ mVrms$	—	80	—	dB	

Coil Data

Coil No.	Test Freq.	L (μH)	Co (pF)	Qo	Turns					Wire (mm ϕ)	Reference
					1-2	2-3	1-3	1-4	4-6		
L ₁ FM RF	100 MHz z	—	—	79	—	—	2 $\frac{1}{2}$	—	—	0.16UEW	Toko Co., Ltd. 666SNF-305NK
L ₂ FM OSC	100 MHz z	—	—	76	—	—	2	—	—	0.16UEW	Toko Co., Ltd. 666SNF-306NK
T ₁ AM OSC	796 kHz z	268	—	65	19	95	—	—	—	0.05UEW	Toko Co., Ltd. 5PNR-5146Y
T ₂ AM IFT	455 kHz z	—	470	60	—	—	109	—	7	0.05UEW	Toko Co., Ltd. 5PLG-5147X

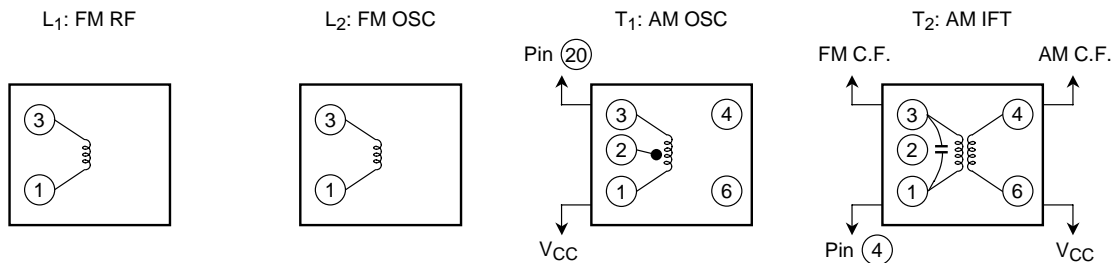

Test Circuit

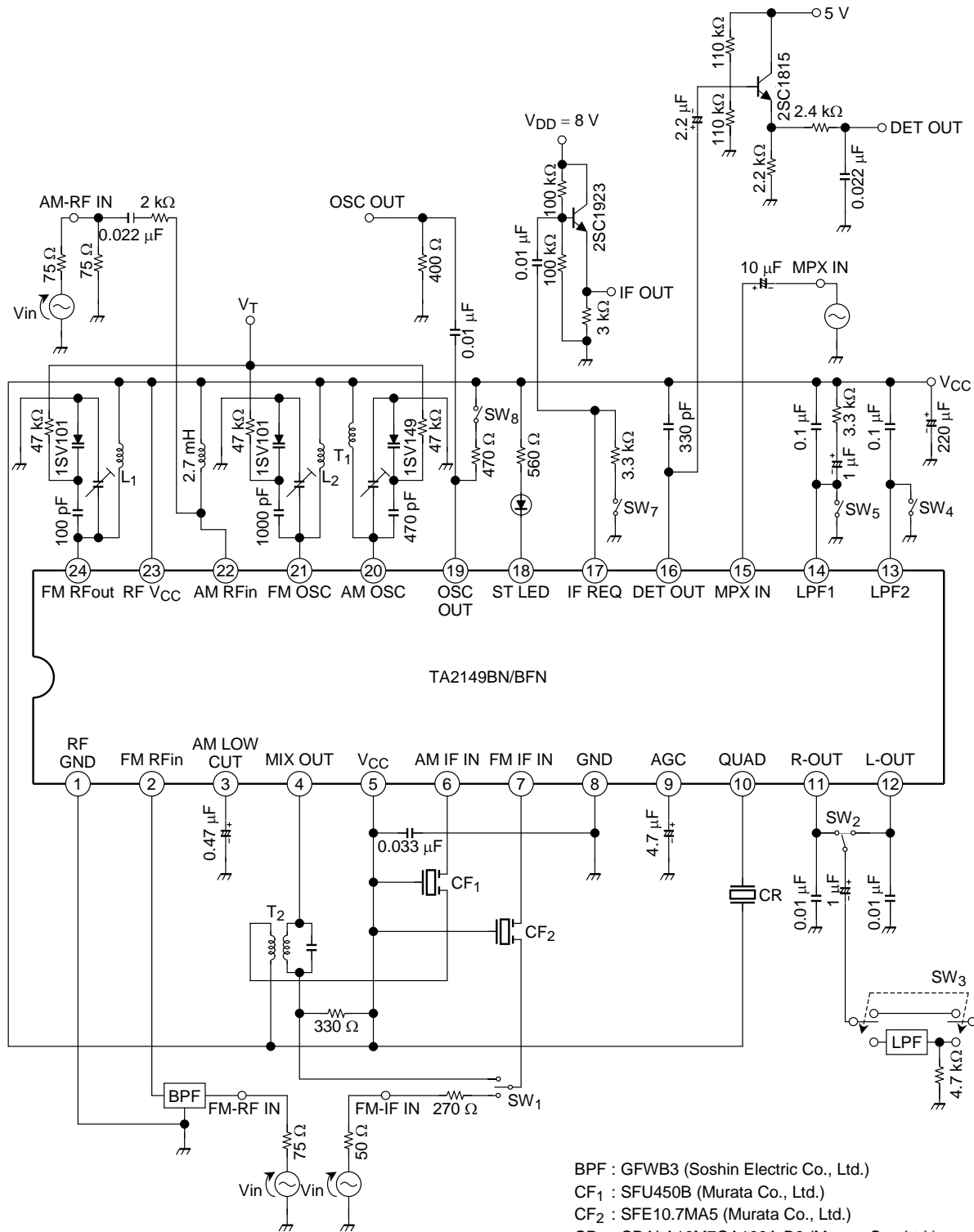

Package Dimensions

SDIP24-P-300-1.78

Unit : mm

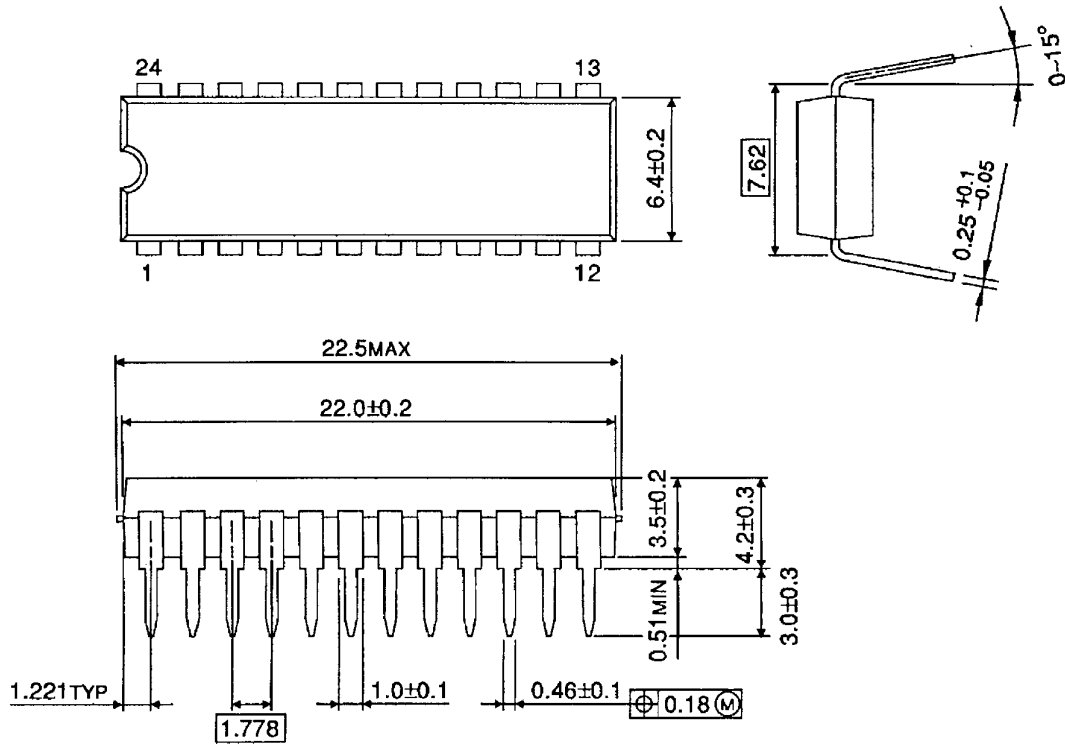

Weight: 1.2 g (typ.)

Package Dimensions

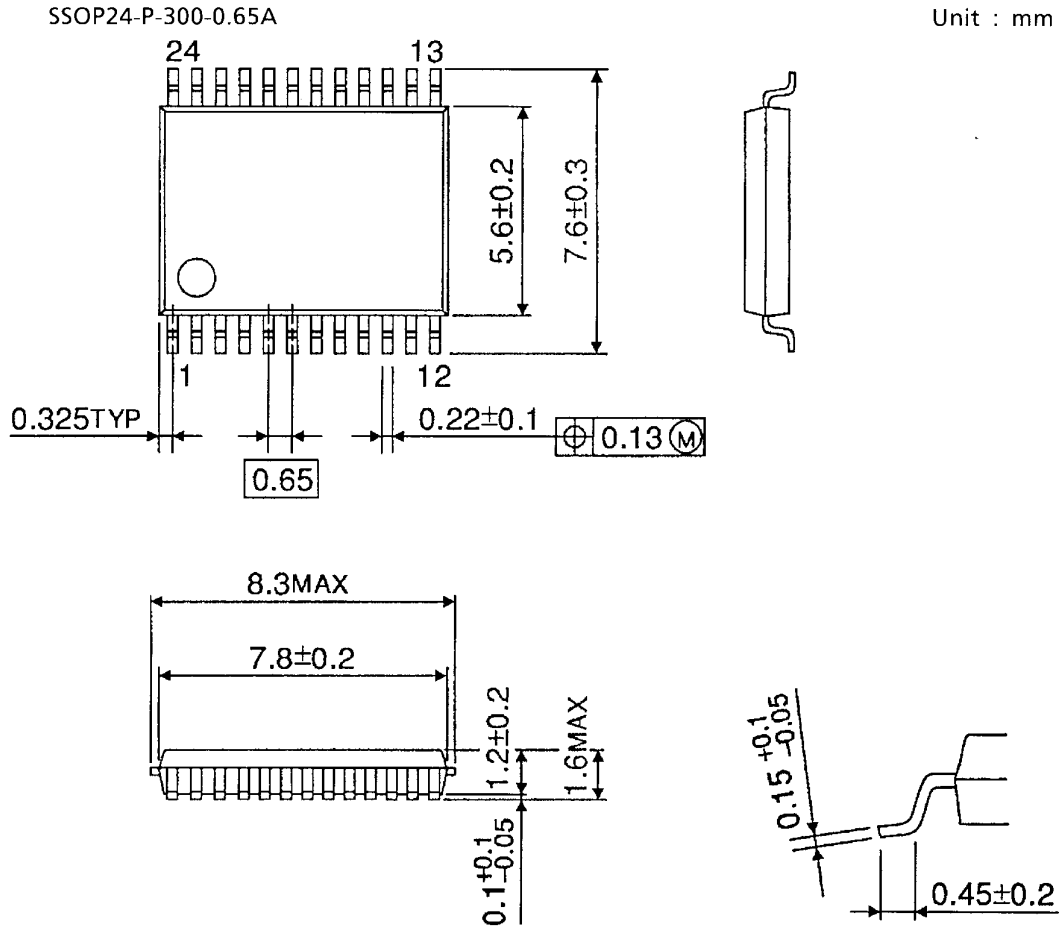

Weight: 0.14 g (typ.)

RESTRICTIONS ON PRODUCT USE

000707EBA

- TOSHIBA is continually working to improve the quality and reliability of its products. Nevertheless, semiconductor devices in general can malfunction or fail due to their inherent electrical sensitivity and vulnerability to physical stress. It is the responsibility of the buyer, when utilizing TOSHIBA products, to comply with the standards of safety in making a safe design for the entire system, and to avoid situations in which a malfunction or failure of such TOSHIBA products could cause loss of human life, bodily injury or damage to property.
In developing your designs, please ensure that TOSHIBA products are used within specified operating ranges as set forth in the most recent TOSHIBA products specifications. Also, please keep in mind the precautions and conditions set forth in the "Handling Guide for Semiconductor Devices," or "TOSHIBA Semiconductor Reliability Handbook" etc..
- The TOSHIBA products listed in this document are intended for usage in general electronics applications (computer, personal equipment, office equipment, measuring equipment, industrial robotics, domestic appliances, etc.). These TOSHIBA products are neither intended nor warranted for usage in equipment that requires extraordinarily high quality and/or reliability or a malfunction or failure of which may cause loss of human life or bodily injury ("Unintended Usage"). Unintended Usage include atomic energy control instruments, airplane or spaceship instruments, transportation instruments, traffic signal instruments, combustion control instruments, medical instruments, all types of safety devices, etc.. Unintended Usage of TOSHIBA products listed in this document shall be made at the customer's own risk.
- The products described in this document are subject to the foreign exchange and foreign trade laws.
- The information contained herein is presented only as a guide for the applications of our products. No responsibility is assumed by TOSHIBA CORPORATION for any infringements of intellectual property or other rights of the third parties which may result from its use. No license is granted by implication or otherwise under any intellectual property or other rights of TOSHIBA CORPORATION or others.
- The information contained herein is subject to change without notice.