

## Charge Timer

### Description

The U2403B is a monolithic, integrated-bipolar circuit which can be used in applications for time-controlled, constant-current charge. Selection of charge current versus timing is carried out by using the external circuit at Pins 2, 3 and 4. For high current requirement, an external transistor is recommended in series with the battery. To protect the IC against high power loss

(typically  $> 140^{\circ}\text{C}$ ), the oscillator is shut down when the reference voltage is switched off (0 V). The latter also takes place when there is a saturation caused by collector voltage at Pin 1. When the overtemperature has disappeared and the collector voltage at Pin 1 has exceeded the supply voltage ( $V_1 > V_S$ ), charge time operation continues (see flow chart in figure 3).

### Features

- Easy-to-run autonomous dual rate charger
- Constant charge current
- 3 h – 24 h charge time programmable
- Low cost dc regulator
- Overtemperature protection
- Charge-mode indication
- Operation starts at the moment of battery insertion
- Fast charge time-test mode

### Applications

- Cordless telephones
- Low-cost battery-charge timer
- Entertainment

**Package:** DIP8, SO8

### Block Diagram

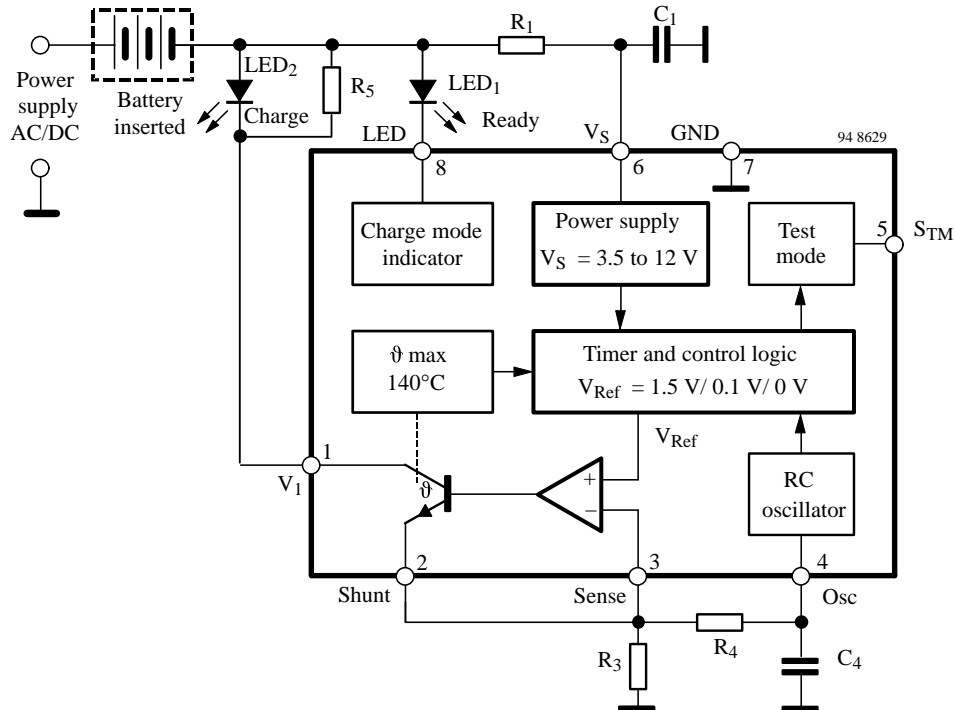
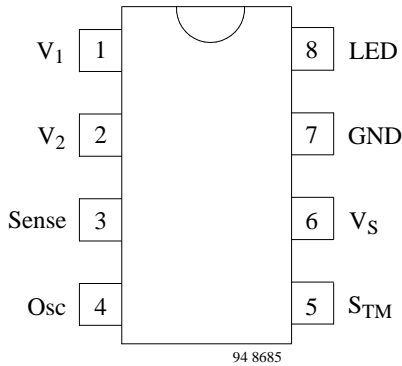

Figure 1. Block diagram with external circuit

## Pin Description



Pin	Symbol	Function
1	V <sub>1</sub>	Collector terminal
2	V <sub>2</sub>	Shunt emitter terminal
3	V <sub>3</sub>	Amplifier sense input
4	Osc	Oscillator input
5	S <sub>TM</sub>	Test mode switch
6	V <sub>S</sub>	Supply voltage
7	GND	Reference point, GND
8	LED	Charge mode indicator

### Pin 1, Collector Voltage V<sub>1</sub>

Pin 1 is an open collector output. When V<sub>1</sub> ≤ 3 V, the charge cycle is switched off until it is above the supply voltage, as shown in figure 6.

### Pin 2, Shunt Emitter

The constant current source is supplied by the internal operational amplifier. The voltage across R<sub>3</sub> is determined via the internal reference source.

$$I_{ch} = V_3/R_3 \quad (V_3 = V_{sense})$$

### Pin 3, Amplifier Sense Input (Inverted)

The voltage-regulated current source has a closed loop at Pin 2, Pin 3, and resistor R<sub>3</sub>.

### Pin 4, Oscillator Input R<sub>4</sub>, C<sub>4</sub>

Selection of current charge versus timing is carried out by using the external circuit at Pins 2, 3, and 4. Typical values are given in charge characteristics (see table next page).

### Pin 5, Test-Mode Switch for Charging Time

The charging time, t<sub>ch</sub>, is given by the following equation.

$$t_{ch} = \frac{1}{f_{osc}} \times 2^n$$

where:

f<sub>osc</sub> = oscillator frequency (see figure 2)

- n = frequency divider
- = 26, if S<sub>TM</sub> open
- = 17, if S<sub>TM</sub> = GND
- = 8, if S<sub>TM</sub> = V<sub>S</sub>

The first eight divider stages can be tested directly. 256 input tact signals at Pin 4 create one tact signal at Pin 5.

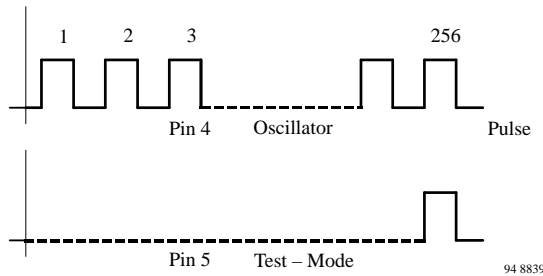

Figure 2. Quick test timer 1/3

### Example

Assume a charge time of 6 h.  
Select the values of R<sub>4</sub> and C<sub>4</sub> from the tables next page.

For example: R<sub>4</sub> = 470 kΩ  
C<sub>4</sub> = 680 pF

There is a frequency of approximately 3100 Hz at Pin 4. It is possible to test the charge time of 6 h by running through the charge cycle for a very short time. By connecting Pin 5 with GND, the test time is 42 s. By connecting Pin 5 with Pin 1 (V<sub>1</sub>), the test time is reduced to about 82.4 ms. R<sub>5</sub> is connected in parallel to the LED<sub>2</sub> and provides a protective bypass function for the LED (see figure 1).

### Pin 6, Supply Voltage, V<sub>S</sub>

V<sub>S</sub> ≈ 3.1 V power-on reset release (turn-on)  
V<sub>S</sub> ≈ 2.9 V under-voltage reset  
V<sub>S</sub> ≈ 13 V supply voltage limitation

### Pin 7, Ground

## Pin 8, Charge Mode Indicator

An open-collector output supplies constant current to LED<sub>1</sub> after the active charge phase has been terminated.  $\theta_{\max}$  controls the function temperature for the final stage range. This is when the temperature is above 140°C and the charge function is therefore switched off.

## Trickle Charge

The trickle charge starts after the charge has been terminated. In this case, the internal reference voltage is reduced from 1.5 V to approximately 0.1 V. This means the charge current is decreased by the factor:

$$K = 1.5 \text{ V} / 0.1 \text{ V} = 15.$$

$$\text{Trickle current} = I_{\text{ch}} / 15 + I_6 \text{ (supply current)} + I_8$$

It is possible to reduce the trickle charge with resistor R<sub>6</sub>, as shown in figures 6 and 7.

## Charge Characteristics

### Charge Time

Test time/ Test-Mode Switch S <sub>TM</sub>			Oscillator Components		Frequency
Open	V <sub>S</sub>	GND	R <sub>4</sub> (KΩ)	C <sub>4</sub> (pF)	f <sub>osc</sub> (Hz)
3 h	41.2 ms	21 s	510	270	6213
			430	330	
			300	470	
4 h	54.9 ms	28 s	620	330	4660
			430	470	
			300	680	
5 h	68.6 ms	35 s	510	470	3728
			390	680	
			300	1000	
6 h	82.4 ms	42 s	620	470	3105
			470	680	
			360	1000	
7 h	96.1 ms	49 s	560	680	2663
			430	1000	
			220	2200	
8 h	109.8 ms	56 s	620	680	2330
			470	1000	
			200	2200	
9 h	123.6 ms	1 min 3 s	750	680	2071
			510	1000	
			240	2200	
10 h	137.3 ms	1 min 10 s	620	820	1864
			270	2200	
			130	4700	
12 h	164.8 ms	1 min 24 s	390	2200	1553
			150	4700	
16 h	219.7 ms	1 min 56 s	470	2200	1165
			200	4700	

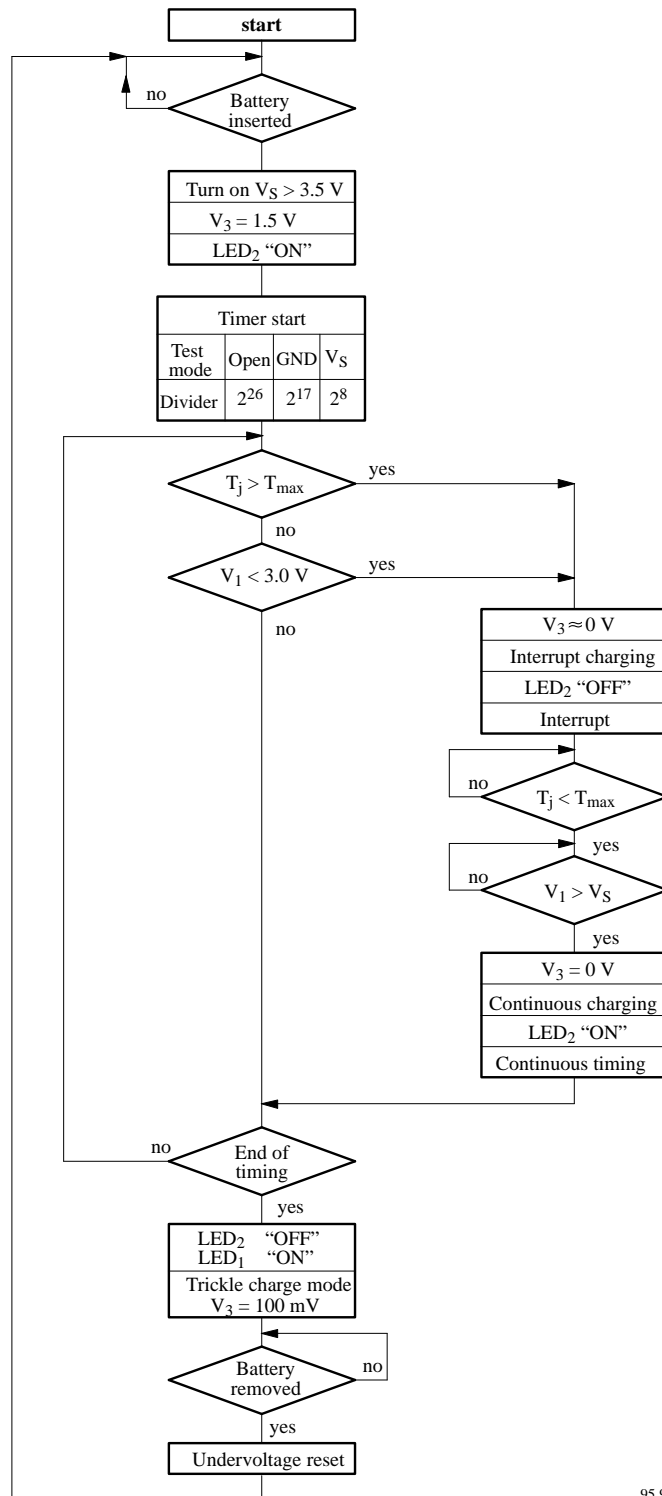

95 9624

Figure 3. Flow chart

## Absolute Maximum Ratings

Reference point Pin 7 (GND), unless otherwise specified.

Parameters	Symbol	Value	Unit
Supply current Pin 6 $t \leq 100 \mu\text{s}$	$I_S$	20	mA
	$i_s$	100	mA
Currents Pin 1 Pin 2 Pin 3 Pin 4 Pin 5 Pin 8	$I_1$	300	mA
	$-I_2$	310	mA
	$I_3$	1	$\mu\text{A}$
	$I_4$	15	mA
	$I_5$	-75 to +120	$\mu\text{A}$
	$I_8$	8	mA
Voltages Pins 1, 3, 5, 6 and 8 Pin 2 Pin 4	$V$	13.5	V
	$V_2$	1.6	
	$V_4$	1.5	
Junction temperature	$T_j$	150	$^{\circ}\text{C}$
Ambient temperature	$T_{\text{amb}}$	10 to 85	$^{\circ}\text{C}$
Storage temperature range	$T_{\text{stg}}$	-50 to +150	$^{\circ}\text{C}$

## Thermal Resistance

Parameters	Symbol	Value	Unit
Junction ambient DIP8 SO8 on PC-board SO8 on ceramic SO8 on ceramic with thermal compound	$R_{\text{thJA}}$	120	K/W
		220	
		140	
		80	

## Electrical Characteristics

$V_S = 6\text{ V}$ ,  $T_{\text{amb}} = 25^\circ\text{C}$ , reference point Pin 7 (GND), unless otherwise specified.

Parameters	Test Conditions / Pins	Symbol	Min.	Typ.	Max.	Unit
Supply voltage limitation	Pin 6 $I_S = 4\text{ mA}$ $I_S = 20\text{ mA}$	$V_S$	12.5		13.5	V
			12.6		13.7	
Supply current	$V_S = 6\text{ V}$	$I_S$	1.4		2.2	mA
<b>Voltage monitoring</b> Pin 6						
Turn-on threshold		$V_{\text{TON}}$	2.8		3.5	V
Turn-off threshold		$V_{\text{TOFF}}$	2.5		3.2	
<b>Charge-mode indicator (LED)</b> Pin 8						
LED current		$I_g$	3.0		6.0	mA
LED saturation voltage	$I_g = 3.7\text{ mA}$	$V_g$			960	mV
Leakage current		$I_{\text{lk}g}$	-0.35		1.1	$\mu\text{A}$
<b>Collector terminal, Figure 5</b> Pin 1						
Open collector current		$I_{\text{CO}}$	15		55	$\mu\text{A}$
Saturation threshold	$V_S = 6\text{ V}$	$V_{\text{TON}}$ $V_{\text{TOFF}}$	2.55 $V_S - 1\text{V}$	3.0 $V_S$	3.35 $V_S - 0.4\text{V}$	V
Shunt emitter current	$R_3 = 5.6\ \Omega$ Pin 2	$I_2$	250		285	mA
<b>Operational sense amplifier, Figure 1</b> Pin 3						
Input current	$V_3 = 0\text{ V}$	$I_3$	-0.6		0.08	$\mu\text{A}$
Input voltage	$V_{\text{Ref}} = 1.5\text{ V}$ $V_{\text{Ref}} = 100\text{ mV}$ $V_{\text{Ref}} = 0\text{ V}$	$V_3$	1.42	1.5	1.58	V
			40	70	100	mV
			-0.4		40	mV
<b>Oscillator</b> Pin 4						
Leakage current	$V_4 = 0\text{ to }0.85\text{ V}$	$I_{\text{lk}g}$	-0.5		0.1	$\mu\text{A}$
Threshold voltage	Upper	$V_{\text{T(u)}}$	875		985	mV
Oscillator frequency	$R_4 = 160\text{ k}\Omega$ , $C_4 = 2.2\text{ nF}$ $R_4 = 680\text{ k}\Omega$ , $C_4 = 4.7\text{ nF}$	$f_{\text{osc}}$	2700		3050	Hz
			305		345	
<b>Test mode switch (<math>S_{\text{TM}}</math>)</b> Pin 5						
Input current	$V_5 = 6\text{ V}$ $V_5 = 0\text{ V}$	$I_5$	40		120	$\mu\text{A}$
			-75		-20	
Output voltage	High Low	$V_{0(\text{H})}$ $V_{0(\text{L})}$	1.7		2.5	V
			0.5		1.0	

**Internal Temperature Switch**

The internal temperature monitoring is active if the chip temperature rises above 140°C. Above this temperature the voltage at Pin 3 goes to zero. Similarly, the charge current,  $I_{ch}$ , reduces according to the equation:

$$I_{ch} = V_3 / R_3$$

where  $I_{ch} = 1$  to 2 mA (IC supply current)

The oscillator is connected to GND via Pin 3 ( $V_3$ ) which holds the present time status. When the chip temperature decreases below the transition value, all functions are released and the charge time is continued. The process is reversible. If there is a higher power dissipation in the circuit ( $T_j > 140^\circ\text{C}$ ), the temperature monitoring remains permanently activated (ON). The total cycle time is prolonged according to the interrupt-time duration, see figure 4.

**Automatic Control Protection**

To reduce the design costs, it is possible to select the transformer which requires minimum power supply.

The output stage of the control is selected so that it is switched off before saturation is achieved ( $V_{CEsat} = 3.0$  V). In this case, the voltage at Pin 3 is kept at a value of zero. The charge current is also zero and the transformer is now an open circuit impedance. The system becomes active again if  $V_1 \geq V_S$ .

The advantage of the system is that if sags of short duration appear on the mains voltage or if the transformers used are too small, the charge duration is increased, but the charge capacity remains the same (see figure 5).

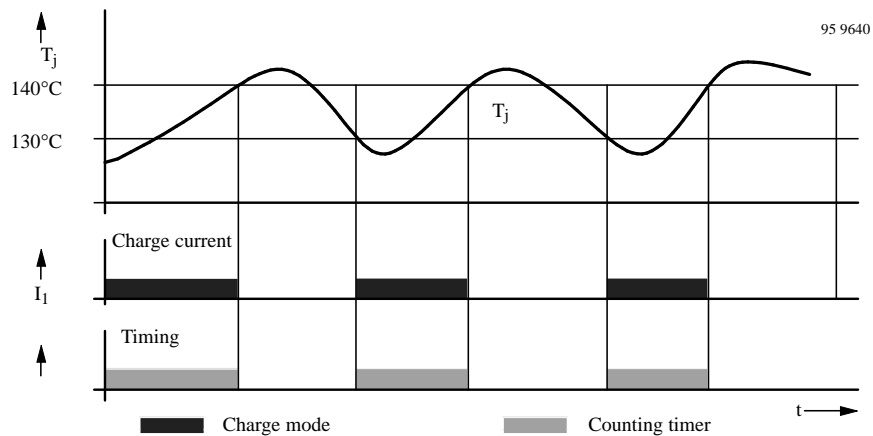

Figure 4. Charge duration – overtemperature

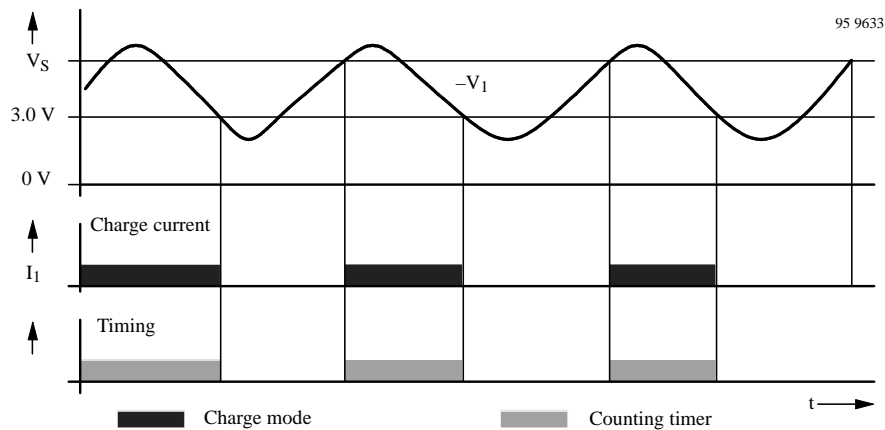

Figure 5. Charge duration –  $V_1$

## Standard Applications

### Basic Example

NiCd battery 750 mAh	$R_1 = 510 \Omega$ , 1/8 W
Charging time: 3 h	$C_1 = 47 \mu\text{F}$ / 16 V
Charge current: 240 mA, 1/3 C	$R_3 = 6.2 \Omega$ , 1/2 W
Trickle charge: 19 mA < 1/40 C	$R_4 = 300 \text{k}\Omega$
	$C_4 = 470 \text{pF}$
	$R_5 = 8.2 \Omega$ , 1/2 W

### Minimum Supply Voltage

No of Cells	DC Supply Minimum
1	6.8 V
2	8.3 V
3	9.8 V
4	11.3 V
5	12.8 V

### Special Requirements of Different Charge Times

$R_4$ ,  $C_4$  values for different charging times

	2 h	4 h	6 h	7 h	12 h
$R_4$	300 k $\Omega$	430 k $\Omega$	470 k $\Omega$	470 k $\Omega$	390 k $\Omega$
$C_4$	330 pF	470 pF	680 pF	1 nF	2.2 nF

### Special Requirements for Different Charge Current

$R_3$ ,  $R_5$  values for different charge current

	240 mA	150 mA	100 mA	50 mA
$R_3$	6.2 $\Omega$	10 $\Omega$	15 $\Omega$	30 $\Omega$
$R_5$	8.2 $\Omega$	15 $\Omega$	22 $\Omega$	68 $\Omega$

### Basic Equations

$$R_1 = 0.5 \text{ V} / I_S$$

$$I_S = 1.8 \text{ mA}$$

$$R_5 = V_5 / (I_{\text{ch}} - 20 \text{ mA})$$

### Nominal Charge Current:

$$I_{\text{ch}} = V_3 / R_3 \text{ where } V_3 = 1.48 \text{ V (typ.)}$$

### Trickle Current:

$$I_{\text{ch}} = V_3 / R_3 + I_8 + I_5$$

Typical values are:

$$V_3 = 100 \text{ mV}, I_8 = 4.5 \text{ mA}$$

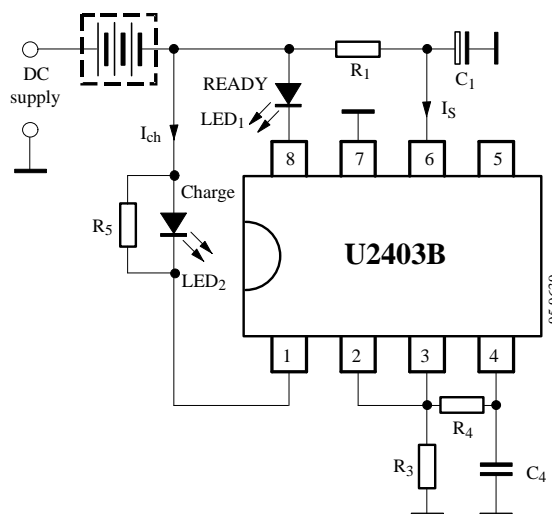

Figure 6. Standard application



## Booster and Trickle Charge Reduction

### Basic Example

NiCd battery 1000 mAh	$R_1 = 510 \Omega$ , 1/8 W
Charging time: 2 h	$C_1 = 100 \mu\text{F}$ / 16 V
Charge current: 500 mA	$R_3 = 3 \Omega$ / 1 W
Trickle charge: 22 mA < 1/22 C	$R_4 = 300 \text{ k}\Omega$
	$C_4 = 330 \text{ pF}$
	$R_5 = 3.9 \Omega$ / 1 W
	$C_2 = 1 \mu\text{F}$

### Supply Voltage

No of Cells	DC Supply Minimum
1	$V_S = 6.5 \text{ V}$
2	8.0 V
3	9.5 V
4	11.0 V
5	12.5 V

### Special Requirements for Different Charge Times

$R_4$ ,  $C_4$  values for different charge times

	2 h	4 h	6 h	7 h	12 h
$R_4$	300 k $\Omega$	430 k $\Omega$	470 k $\Omega$	470 k $\Omega$	390 k $\Omega$
$C_4$	330 pF	470 pF	680 pF	1 nF	2.2 nF

### Special Requirements for Different Charge Current

$R_3$ ,  $R_5$  values for different charge currents

	616 mA	493 mA	411 mA	296 mA
$R_3$	2.4 $\Omega$	3 $\Omega$	3.6 $\Omega$	5 $\Omega$
$R_5$	3 $\Omega$	3.9 $\Omega$	4.7 $\Omega$	6.8 $\Omega$

$R_6 = 560 \Omega$ , reduced trickle charge

### Basic Equations

$$R_1 = 0.5 \text{ V} / I_S$$

$$R_5 = V(\text{LED}_2) / (I_{\text{ch}} - 20 \text{ mA})$$

### Nominal Charge Current:

$$I_{\text{ch}} = V_3 / R_3$$

$V_3 = 1.48 \text{ V}$ , typically

### Trickle Current:

$$I_{\text{ch}} = V_3 / R_3 + I_{\text{LED1}} + I_S - I_6$$

Typical values:

$$V_3 = 100 \text{ mV}$$

$$I_{\text{LED1}} = 4.5 \text{ mA}$$

$$I_S = 1.8 \text{ mA}$$

### Trickle-Charge Reduction ( $I_6$ )

$$I_6 = (V_{\text{Batt}} + V_{\text{D1}}) / R_6 \quad V_{\text{D1}} = 0.75 \text{ V}$$

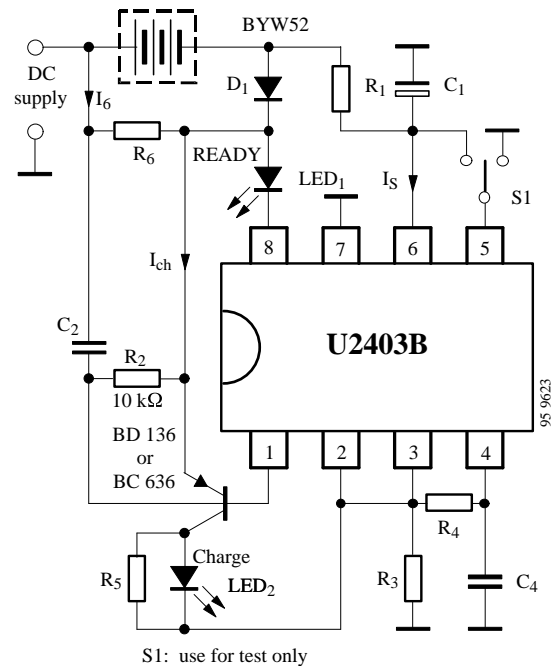

Figure 7. Application for charge current > 250 mA

To fulfill requirements of higher charge current an external booster transistor can be used (see figure 7). As the temperature cannot be monitored in this case a heat sink with a reasonable size should be used for safe operation. Test mode switch  $S_1$  can be used for accelerated production check.



**Package Information**

Package DIP8  
Dimensions in mm

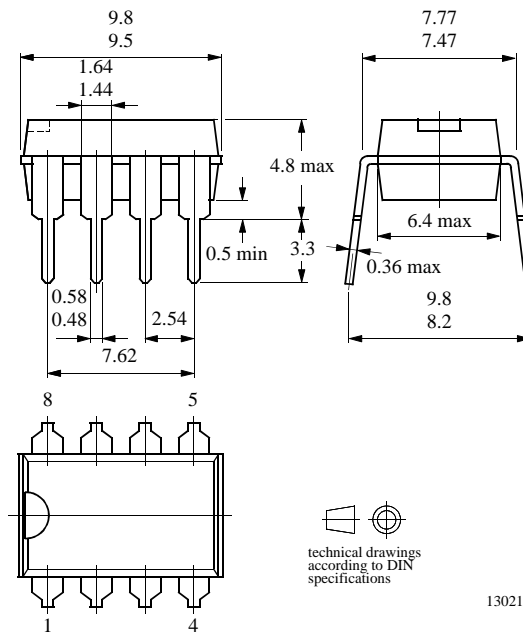

Package SO8  
Dimensions in mm

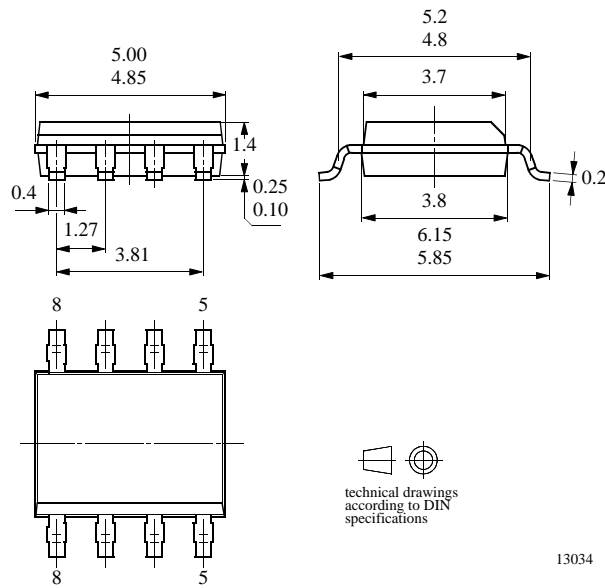

## Ozone Depleting Substances Policy Statement

It is the policy of **TEMIC TELEFUNKEN microelectronic GmbH** to

1. Meet all present and future national and international statutory requirements.
2. Regularly and continuously improve the performance of our products, processes, distribution and operating systems with respect to their impact on the health and safety of our employees and the public, as well as their impact on the environment.

It is particular concern to control or eliminate releases of those substances into the atmosphere which are known as ozone depleting substances (ODSs).

The Montreal Protocol (1987) and its London Amendments (1990) intend to severely restrict the use of ODSs and forbid their use within the next ten years. Various national and international initiatives are pressing for an earlier ban on these substances.

**TEMIC TELEFUNKEN microelectronic GmbH** semiconductor division has been able to use its policy of continuous improvements to eliminate the use of ODSs listed in the following documents.

1. Annex A, B and list of transitional substances of the Montreal Protocol and the London Amendments respectively
2. Class I and II ozone depleting substances in the Clean Air Act Amendments of 1990 by the Environmental Protection Agency (EPA) in the USA
3. Council Decision 88/540/EEC and 91/690/EEC Annex A, B and C (transitional substances) respectively.

**TEMIC** can certify that our semiconductors are not manufactured with ozone depleting substances and do not contain such substances.

**We reserve the right to make changes to improve technical design and may do so without further notice.**

Parameters can vary in different applications. All operating parameters must be validated for each customer application by the customer. Should the buyer use TEMIC products for any unintended or unauthorized application, the buyer shall indemnify TEMIC against all claims, costs, damages, and expenses, arising out of, directly or indirectly, any claim of personal damage, injury or death associated with such unintended or unauthorized use.

TEMIC TELEFUNKEN microelectronic GmbH, P.O.B. 3535, D-74025 Heilbronn, Germany  
Telephone: 49 (0)7131 67 2831, Fax number: 49 (0)7131 67 2423