

DATA SHEET

TDA3827

TV-sound demodulator circuit with
SCART switches and AF control

Preliminary specification
File under Integrated Circuits, IC02

March 1991

TV-sound demodulator circuit with SCART switches and AF control

TDA3827

FEATURES

- Wide supply voltage range from 4.5 V to 13.2 V
- Wide frequency range from 4 to 12 MHz
- High ripple rejection
- High precision and temperature compensated FM-demodulator output
- Multiple-input AF operational amplifiers with offset compensation
- SCART AF input / AF output (low impedance)
- External AF input
- High-level AF output voltage with low distortion
- External selection of the source selector AF gain
- Low switching noise between AF and mute
- Wide volume-control range

GENERAL DESCRIPTION

The TDA3827 contains a single FM demodulator with SCART switches, a mute function and volume control.

QUICK REFERENCE DATA

SYMBOL	PARAMETER	CONDITIONS	MIN.	TYP.	MAX.	UNIT
V_P	supply voltage range (pin 18)		4.5	5.0	13.2	V
I_P	supply current (pin 18)	$V_P = 5\text{ V}$	–	26	–	mA
		$V_P = 12\text{ V}$	–	28	–	mA
$(S+N)/N$	signal to weighted noise		73	78	–	dB
$V_{5(rms)}$	FM demodulator output voltage (RMS value)	$\Delta f = 50\text{ kHz};$ $f_{mod} = 1\text{ kHz};$ $Q_L = 20$	450	500	550	mV
$V_{13(rms)}$	SCART output signal (RMS value)		–	1.0	–	V
G_V	volume control range		80	85	–	dB
$V_{17(rms)}$	AF output signal (RMS value)	$\Delta f = 50\text{ kHz};$ $f_{mod} = 1\text{ kHz};$ $Q_L = 20$	–	1.0	–	V
THD	total harmonic distortion (pin 17)		–	0.5	–	%

ORDERING AND PACKAGE INFORMATION

EXTENDED TYPE NUMBER	PACKAGE			
	PINS	PIN POSITION	MATERIAL	CODE
TDA3827	18	DIL	plastic	SOT102 ⁽¹⁾

Note

1. SOT102-2; 1996 December 13.

TV-sound demodulator circuit with SCART switches and AF control

TDA3827

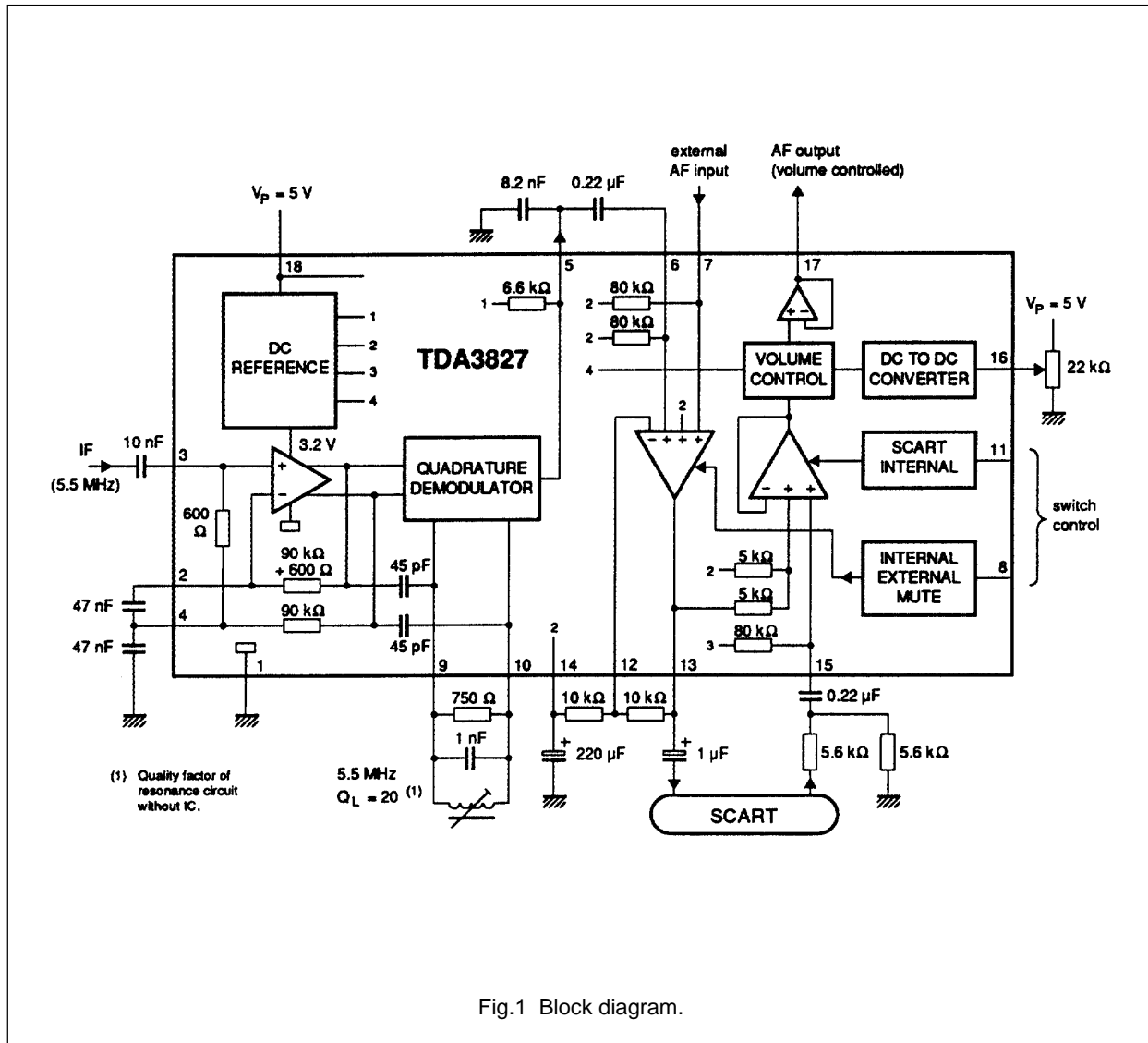

TV-sound demodulator circuit with SCART switches and AF control

TDA3827

PIN CONFIGURATION

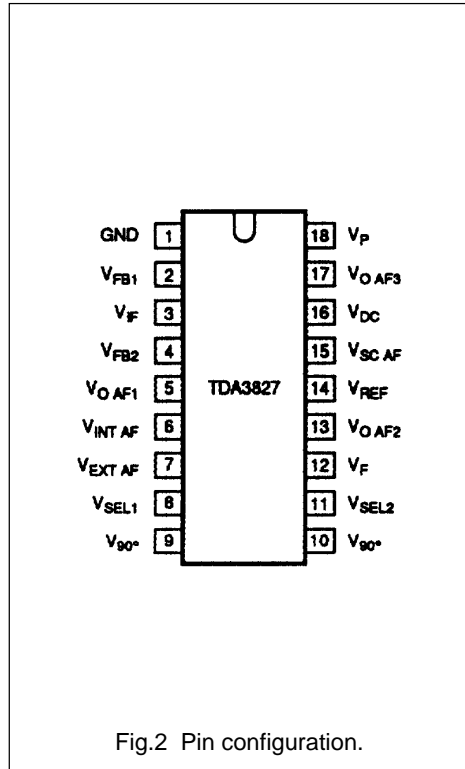

PINNING

SYMBOL	PIN	DESCRIPTION
GND	1	ground
V _{FB1}	2	limiter amplifier feedback
V _{IF}	3	FM IF input signal
V _{FB2}	4	limiter amplifier feedback
V _{O AF1}	5	AF output signal
V _{INT AF}	6	internal AF input signal
V _{EXT AF}	7	external AF input signal
V _{SEL1}	8	selection voltage for internal / external AF input and mute
V _{90°}	9	quadrature demodulator tuned circuit reference
V _{90°}	10	quadrature demodulator tuned circuit reference
V _{SEL2}	11	selection voltage for internal / external or SCART audio
V _F	12	source selector feedback
V _{O AF2}	13	output signal to SCART
V _{REF}	14	reference voltage
V _{SC AF}	15	input signal from SCART
V _{DC}	16	DC volume control voltage
V _{O AF3}	17	AF output signal from volume control
V _P	18	supply voltage

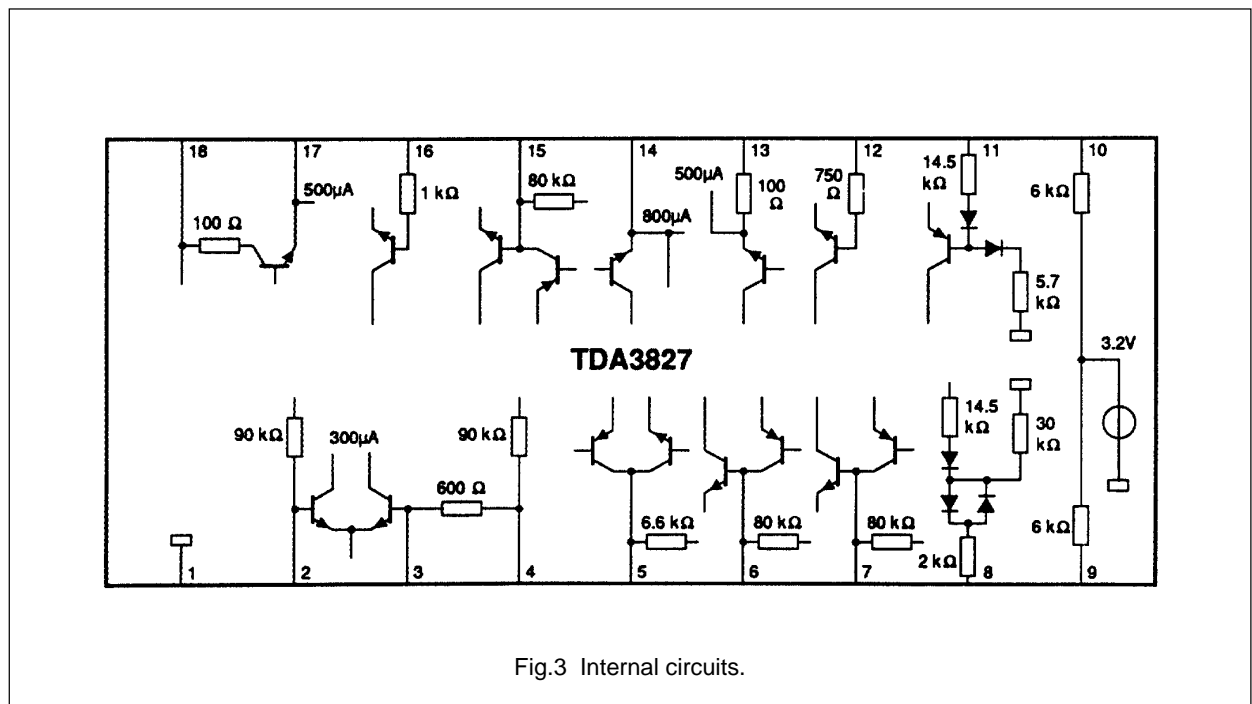

**TV-sound demodulator circuit with SCART
switches and AF control**

TDA3827**LIMITING VALUES**

In accordance with the Absolute Maximum System (IEC 134)

SYMBOL	PARAMETER	MIN.	MAX.	UNIT
V_P	supply voltage (pin 18)	-0.5	$V_P + 6.8$	V
V_{ext}	external voltage (pins 2 to 10, 12 to 15 and 17)	-0.3	$V_P - 0.7$	V
	external voltage at pin 11	-0.3	13.2	V
	external voltage at pin 16	-0.3	V_P	V
R_L	external DC load resistance (pin 13 and pin 17)	5.0	-	k Ω
C_L	capacitive output load (pin 13 and pin 17)	-	1500	pF
P_{tot}	total power dissipation	-	450	mW
T_{stg}	storage temperature range	-40	+ 150	$^{\circ}\text{C}$
T_{amb}	operating ambient temperature range	0	+ 70	$^{\circ}\text{C}$
V_{ESD}	ESD-protection (note 1)	± 2000	-	V

Note to the limiting values

1. Measured with a 100 pF capacitor in series with a 1.5 k Ω resistor.

TV-sound demodulator circuit with SCART switches and AF control

TDA3827

CHARACTERISTICS

All voltages are measured to GND (pin 1); $V_P = 5\text{ V}$; $V_{IF} = 10\text{ mV}$; $f_o = 5.5\text{ MHz}$; $f_{AF} = 1\text{ kHz}$; $\Delta f = 50\text{ kHz}$; $T_{amb} = 25\text{ }^\circ\text{C}$; measured in test circuit of Fig.4.; unless otherwise specified.

SYMBOL	PARAMETER	CONDITIONS	MIN.	TYP.	MAX.	UNIT
V_P	supply voltage.range (pin 18)		4.5	5.0	13.2	V
I_P	supply current (pin 18)	$V_P = 5.0\text{ V}$	–	26	30	mA
		$V_P = 12.0\text{ V}$	–	28	32	mA
V_{14}	reference voltage		2.2	2.3	2.4	V
I_{14}	output current		–	± 250	–	μA
IF limiting amplifier						
$V_{i(\text{rms})}$	input signal at pin 3 (RMS value)		–	–	200	mV
		3 dB below nominal AF level at pin 5	–	30	50	μV
R_{3-1}	input resistance		–	600	–	Ω
$V_{2,3,4}$	DC voltage		–	2.1	–	V
FM demodulator ($Q_L = 20$)						
$V_{5(\text{rms})}$	AF-output signal (RMS value)		450	500	550	mV
	residual $2f_o$ -signal (RMS value)	without de-emphasis	–	–	30	mV
TC	temperature coefficient (pin 5)		–	1	2	mV/K
α_{AM}	AM suppression	$f_{AM} = 400\text{ Hz}$, $m = 0.3$, $V_{i(\text{rms})} = 500\text{ } \mu\text{V}$; Fig.8	50	62	–	dB
THD	total harmonic distortion	see Fig.8	–	0.3	0.5	%
Z_o	output impedance (pin 5)		–	6.6	–	k Ω
B_{AF1}	small signal bandwidth (pin 5)	at -1 dB ; without de-emphasis	100	–	–	kHz
(S+N)/N	signal to weighted noise ratio	CCIR468-3, DIN45405; see Fig.8	73	78	–	dB
RR	ripple rejection	$f_R = 70\text{ Hz}$, $V_R = 100\text{ mV}_{(p-p)}$	30	35	–	dB
$V_{9,10}$	DC voltage		–	3.2	–	V
Source selector						
$V_{i\ 6,7(\text{rms})}$	input signal (RMS value)		–	500	1000	mV
$Z_{6,7}$	input impedance		50	80	–	k Ω
G_o	open loop gain		–	60	–	dB
$G_{13/6,7}$	gain	see Fig.4	–	0	–	dB
	gain (typical application)	see Fig.1	–	6	–	dB
V_{13}	DC voltage		–	2.3	–	V
I_{13}	DC output current		–	–	1.0	mA
Z_{13}	output impedance dynamic		–	–	10	Ω
C_L	capacitive output load (pin 13)		–	–	1500	pF
$V_{13(\text{rms})}$	output signal (RMS value)	handling THD < 0.1 %	–	1.0	1.1	V
	noise voltage (RMS value)	$B_{\text{noise}} = 20\text{ kHz}$	–	20	–	μV

TV-sound demodulator circuit with SCART switches and AF control

TDA3827

SYMBOL	PARAMETER	CONDITIONS	MIN.	TYP.	MAX.	UNIT
B_{AF2}	small signal bandwidth	at -1 dB	100	-	-	kHz
dV/dt	slew rate (pin 13)		1	-	-	V/ μ s
ΔV_{13}	offset-voltage between any two source selector positions		-	5	20	mV
α_{mute}	AF suppression at mute		80	90	-	dB
$\alpha_{7/6}$	crosstalk attenuation		70	76	-	dB
Source selector control (see Fig.5)						
V_8	voltage for internal selection of AF-input (pin 6)		$1/3 V_P$	-	$2/3 V_P - 0.7$	V
I_8	selection input current		-	-	200	μ A
V_8	voltage for external selection of AF-input (pin 7)		$2/3 V_P + 0.7$	-	V_P	V
I_8	selection input current		40	-	600	μ A
V_8	voltage for mute active		0	-	$1/3 V_P - 1$	V
I_8	input current		-10	-	-500	μ A
SCART switch and level control						
$V_{15(rms)}$	AC input signal (RMS value)		-	500	1000	mV
Z_{15}	input impedance		50	80	-	k Ω
G_{17-15}	voltage gain	$V_{16} = 4.1$ V	-1.5	0	+ 1.5	dB
G_{max}	maximum voltage gain	$V_{16} = 5.0$ V	+ 4.0	+ 5.0	+ 6.0	dB
ΔG_V	volume control range	see Fig.7	80	86	-	dB
V_{17}	DC voltage		-	2.3	-	V
I_{17}	DC output current		-	-	-1	mA
Z_{17}	dynamic output impedance		-	-	10	Ω
C_L	capacitive output load (pin 17)		-	-	1500	pF
$V_{17(rms)}$	output signal (RMS value)	THD \leq 1 %	-	1.0	1.1	V
	noise voltage (RMS value)	$B_{noise} = 20$ kHz	-	100	-	μ V
B_{AF3}	small signal bandwidth (pin 17)	at -3 dB	50	100	-	kHz
THD	distortion (pin 17)	at maximum gain	-	0.5	1.0	%
ΔV_{17}	offset voltage between internal and SCART		-	5	20	mV
V_{16}	control voltage	minimum gain -80 dB; see Fig.7	0.7	1.0	-	V
I_{16}	control current		-	-	50	μ A
$\alpha_{6,7/15}$	crosstalk attenuation between IF-stage and control-stage	IF sound modulated; SCART switch on; source-selector on position input 1	80	90	-	dB

TV-sound demodulator circuit with SCART switches and AF control

TDA3827

SYMBOL	PARAMETER	CONDITIONS	MIN.	TYP.	MAX.	UNIT
SCART switch control (see Fig.6)						
V_{11}	voltage for internal active		0	-	$4/5 V_P - 3$	V
I_{11}	current		0	-	-100	μA
V_{11}	voltage for SCART active		$4/5 V_P - 1$	-	13.2	V
I_{11}	current		$\frac{V_{11} - 1.4}{20.000}$	-	700	μA

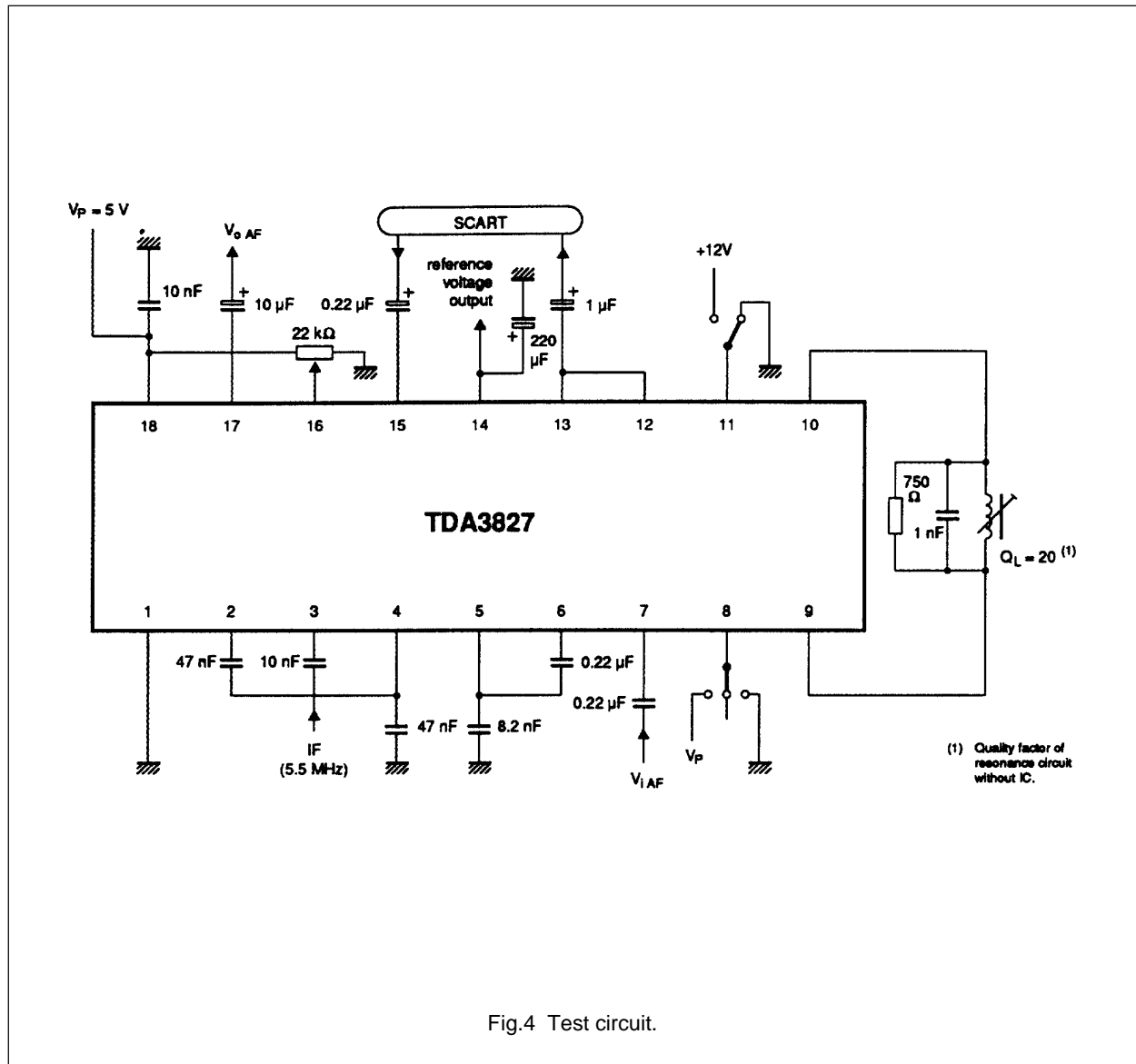
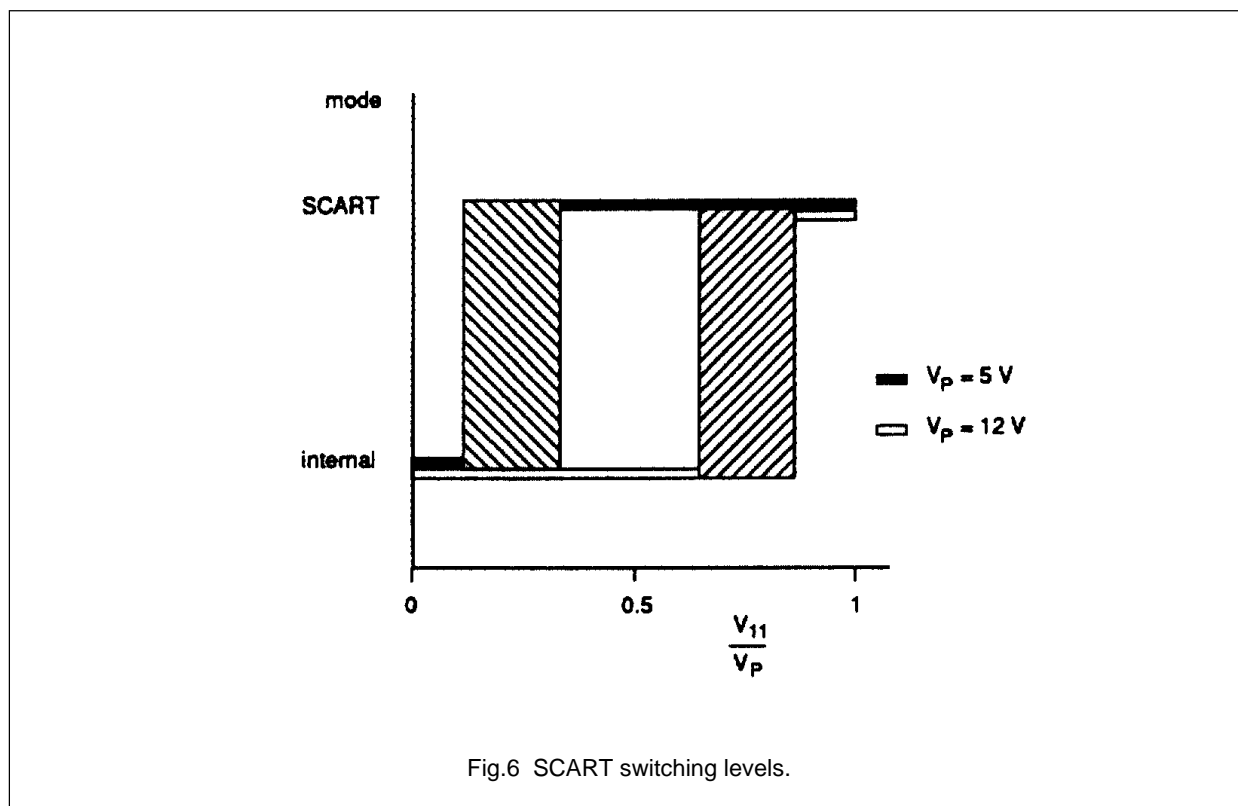
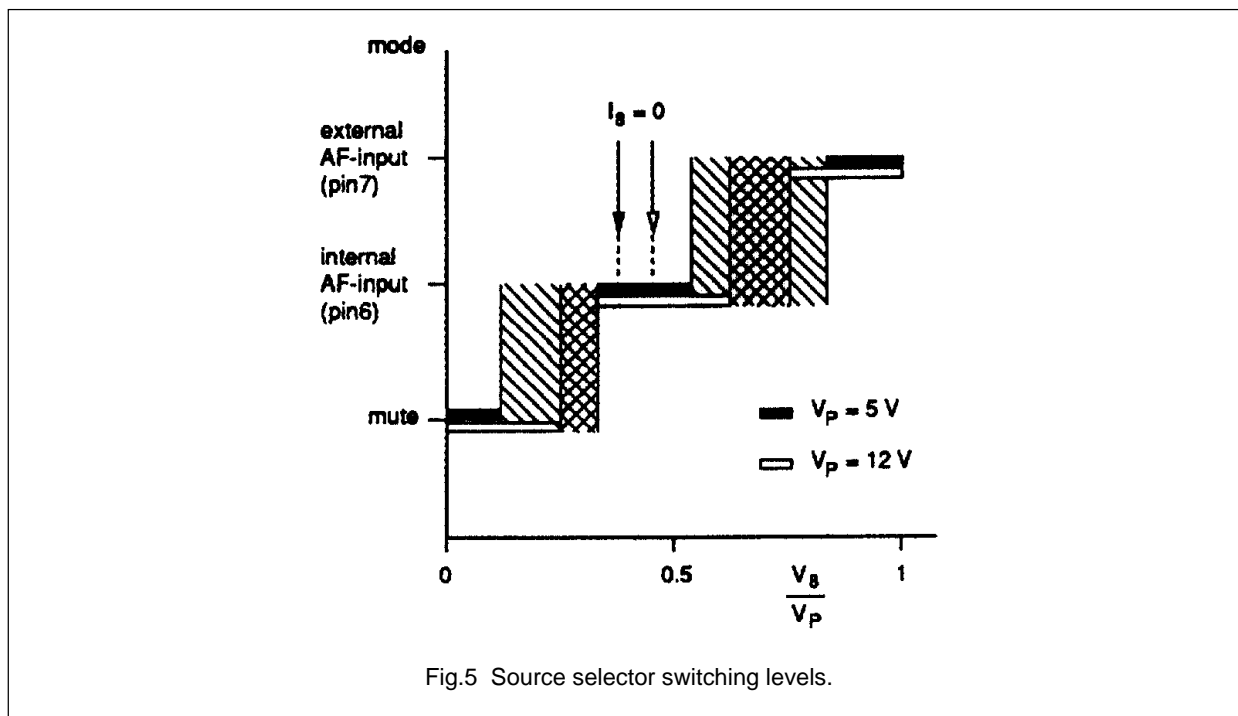

Fig.4 Test circuit.

TV-sound demodulator circuit with SCART
switches and AF control

TDA3827



TV-sound demodulator circuit with SCART switches and AF control

TDA3827

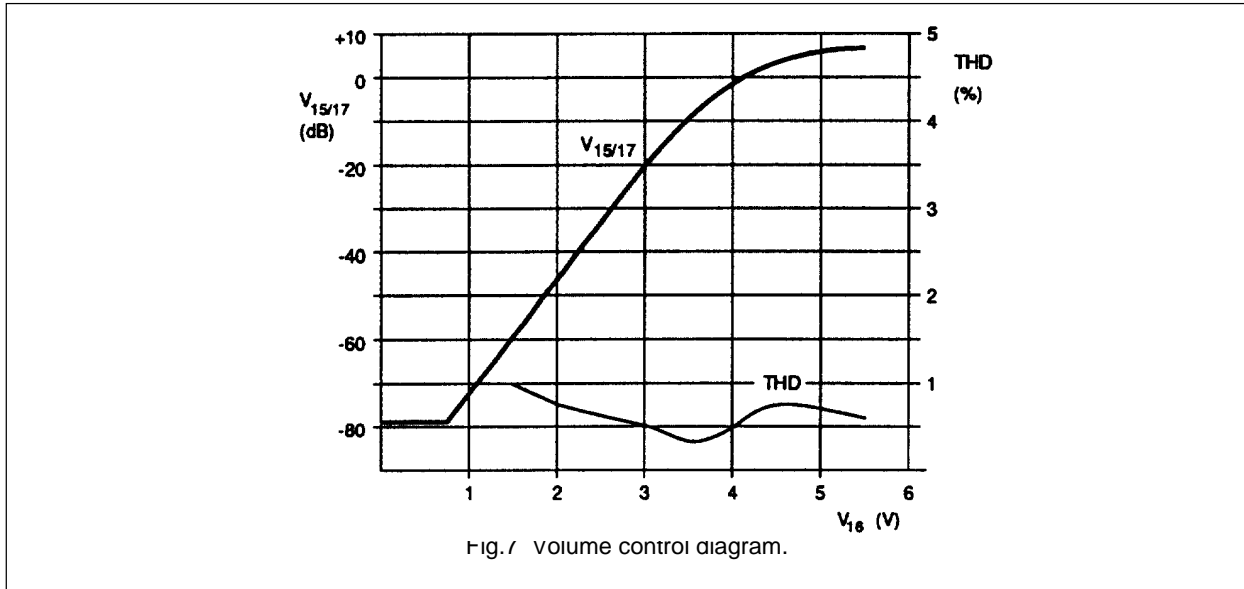

Fig. 7 volume control diagram.

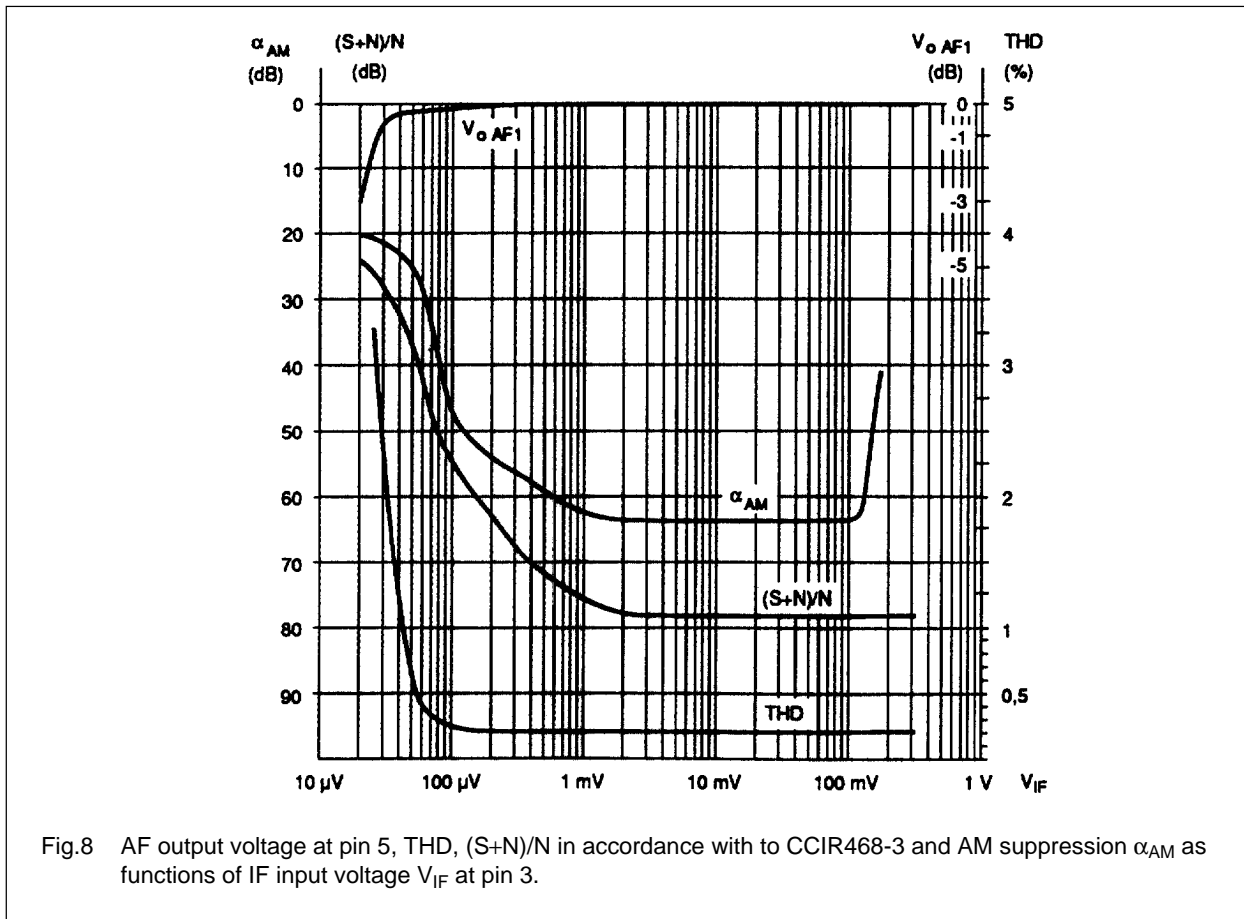

Fig. 8 AF output voltage at pin 5, THD, (S+N)/N in accordance with to CCIR468-3 and AM suppression α_{AM} as functions of IF input voltage V_{IF} at pin 3.

TV-sound demodulator circuit with SCART switches and AF control

TDA3827

PACKAGE OUTLINE

DIP18: plastic dual in-line package; 18 leads (300 mil); slim corner leads

SOT102-2

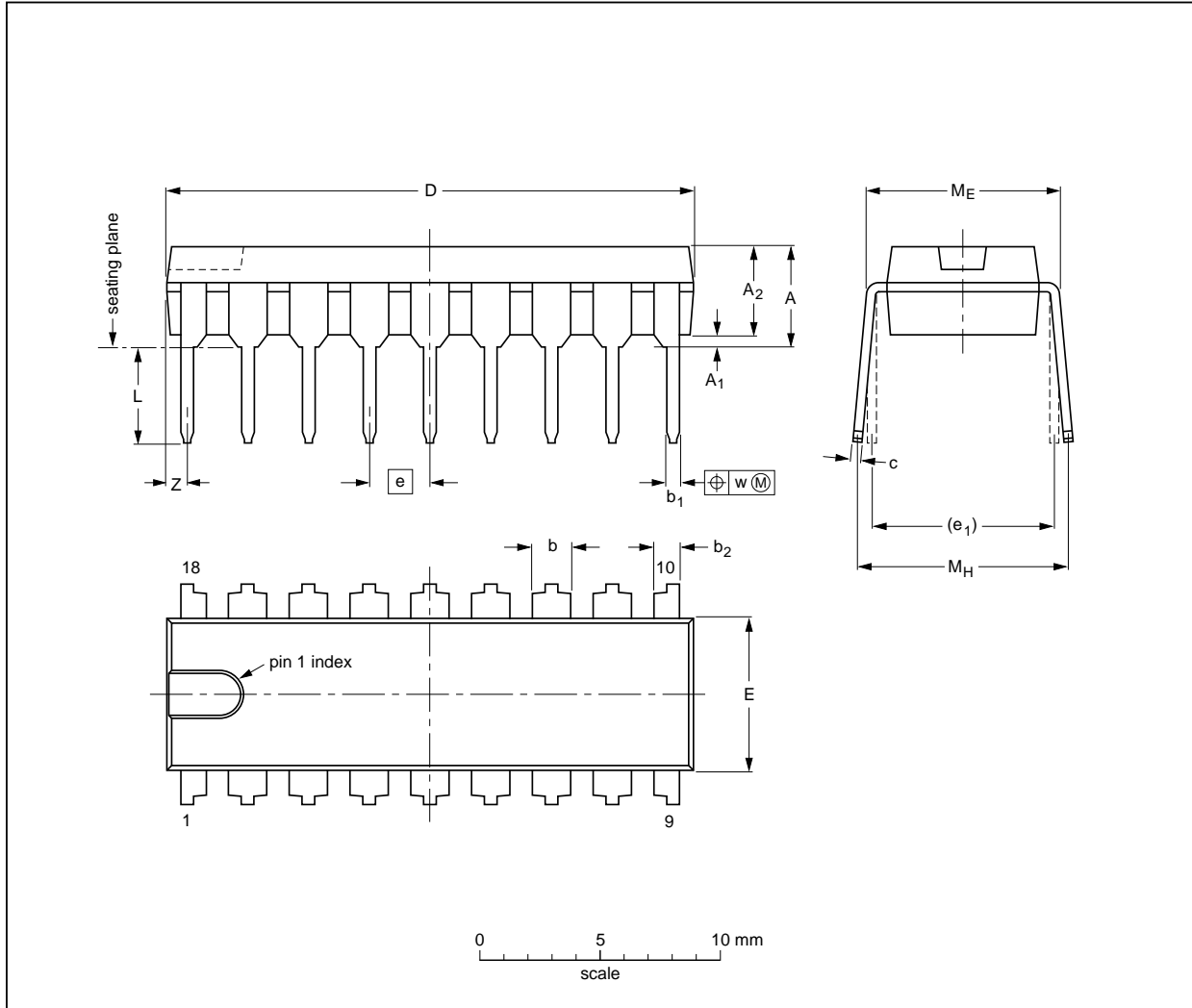

DIMENSIONS (inch dimensions are derived from the original mm dimensions)

UNIT	A max.	A ₁ min.	A ₂ max.	b	b ₁	b ₂	c	D ⁽¹⁾	E ⁽¹⁾	e	e ₁	L	M _E	M _H	w	Z ⁽¹⁾ max.
mm	4.7	0.51	3.7	1.40 1.14	0.53 0.38	1.05 0.75	0.32 0.23	21.8 21.4	6.48 6.20	2.54	7.62	3.9 3.4	8.25 7.80	9.5 8.3	0.254	0.85
inches	0.19	0.020	0.15	0.055 0.045	0.021 0.015	0.041 0.030	0.013 0.009	0.86 0.84	0.26 0.24	0.10	0.30	0.15 0.13	0.32 0.31	0.37 0.33	0.01	0.033

Note

1. Plastic or metal protrusions of 0.25 mm maximum per side are not included.

OUTLINE VERSION	REFERENCES				EUROPEAN PROJECTION	ISSUE DATE
	IEC	JEDEC	EIAJ			
SOT102-2						93-10-14 95-01-23

TV-sound demodulator circuit with SCART switches and AF control

TDA3827

SOLDERING

Introduction

There is no soldering method that is ideal for all IC packages. Wave soldering is often preferred when through-hole and surface mounted components are mixed on one printed-circuit board. However, wave soldering is not always suitable for surface mounted ICs, or for printed-circuits with high population densities. In these situations reflow soldering is often used.

This text gives a very brief insight to a complex technology. A more in-depth account of soldering ICs can be found in our "IC Package Databook" (order code 9398 652 90011).

Soldering by dipping or by wave

The maximum permissible temperature of the solder is 260 °C; solder at this temperature must not be in contact with the joint for more than 5 seconds. The total contact time of successive solder waves must not exceed 5 seconds.

The device may be mounted up to the seating plane, but the temperature of the plastic body must not exceed the specified maximum storage temperature ($T_{stg\ max}$). If the printed-circuit board has been pre-heated, forced cooling may be necessary immediately after soldering to keep the temperature within the permissible limit.

Repairing soldered joints

Apply a low voltage soldering iron (less than 24 V) to the lead(s) of the package, below the seating plane or not more than 2 mm above it. If the temperature of the soldering iron bit is less than 300 °C it may remain in contact for up to 10 seconds. If the bit temperature is between 300 and 400 °C, contact may be up to 5 seconds.

DEFINITIONS

Data sheet status	
Objective specification	This data sheet contains target or goal specifications for product development.
Preliminary specification	This data sheet contains preliminary data; supplementary data may be published later.
Product specification	This data sheet contains final product specifications.
Limiting values	
Limiting values given are in accordance with the Absolute Maximum Rating System (IEC 134). Stress above one or more of the limiting values may cause permanent damage to the device. These are stress ratings only and operation of the device at these or at any other conditions above those given in the Characteristics sections of the specification is not implied. Exposure to limiting values for extended periods may affect device reliability.	
Application information	
Where application information is given, it is advisory and does not form part of the specification.	

LIFE SUPPORT APPLICATIONS

These products are not designed for use in life support appliances, devices, or systems where malfunction of these products can reasonably be expected to result in personal injury. Philips customers using or selling these products for use in such applications do so at their own risk and agree to fully indemnify Philips for any damages resulting from such improper use or sale.