

TOSHIBA (LOGIC/MEMORY)

48E D

9097248 0022011 0 TOS2

32,768 WORD x 8 BIT CMOS PSEUDO STATIC RAM

T-46-23-14

DESCRIPTION

The TC51832 Family is a 256K bit high-speed CMOS Pseudo-Static RAM organized as 32,768 words by 8 bits. The TC51832 Family utilizes one transistor dynamic memory cell array with CMOS peripheral circuitry to achieve large capacity, high speed accesses, and low power requirements, using a single 5V power supply. The $\overline{OE}/RFSH$ input allows two types of refresh operations: Auto Refresh and Self Refresh. The TC51832 Family has a static RAM-like read/write functionality, which allows easy interfacing to a microprocessor. The TC51832 Family is pin-compatible with the 256K bit static RAM. The TC51832P is offered in a standard 28 pin 0.6 inch and 0.3 inch width plastic DIP. The TC51832F is offered in a standard 28 pin 0.450 inch width small out-line plastic flat package.

FEATURES

- Organization: 256K bit(32,768 word x 8 bit)
- Fast Access Time and Low Power Dissipation

- Self refresh uses an internal timer.
- All inputs and outputs: TTL compatible
- 256 refresh cycle/4ms
- Pin Compatible: 256K SRAM TC55257
- Logic Compatible: SRAM R/W Pin
- 28 pin Standard Plastic PKG
 P/PL : 600 mil DIP
 SP/SPL: 300 mil DIP
 F/FL : 450 mil SOP

	TC51832P Family		
	-85	-10	-12
t_{CEA} \overline{CE} Access Time	85ns	100ns	120ns
t_{OEA} \overline{OE} Access Time	35ns	40ns	50ns
t_{RC} Cycle Time	135ns	160ns	190ns
P_D -Operating- Max.	303mW	248mW	220mW
Self Refresh Current	1mA/100 μ A (-L)		

- Single Power Supply: 5V \pm 10%
- Auto refresh uses an internal counter.

PIN CONNECTION

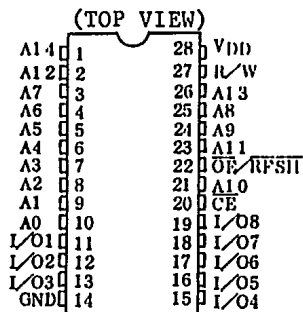

PIN NAMES

A0 ~ A14	Address Inputs
R/W	Read/Write Control Input
$\overline{OE}/RFSH$	Output Enable/Refresh Input
\overline{CE}	Chip Enable Input
I/O1 ~ I/O8	Data Inputs/Outputs
VDD	Power (+5V)
GND	Ground

BLOCK DIAGRAM

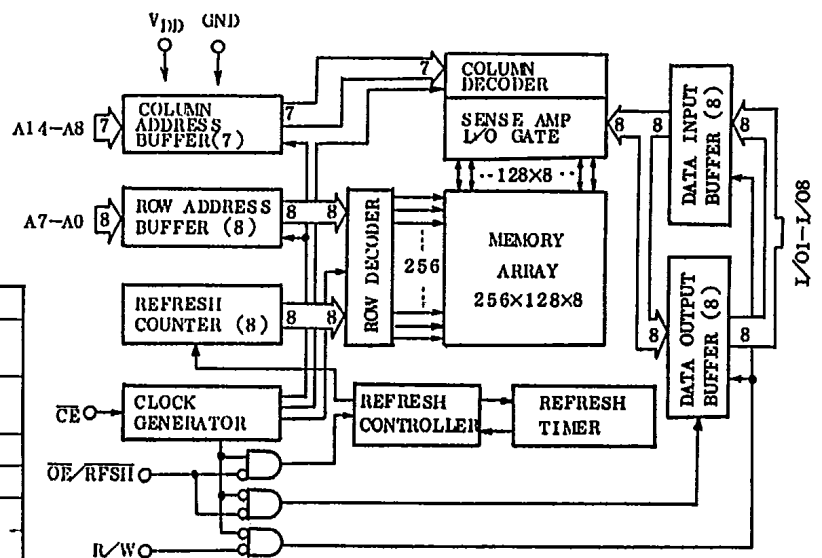

T-46-23-14

ABSOLUTE MAXIMUM RATINGS

SYMBOL	ITEM	RATING	UNITS	NOTE
V _{IN}	Input Voltage	-1.0~7.0	V	1
V _{OUT}	Output Voltage	-1.0~7.0	V	1
V _{DD}	Power Supply Voltage	-1.0~7.0	V	1
T _{OPR}	Operating Temperature	0~70	°C	1
T _{STG}	Storage Temperature	-55~150	°C	1
T _{SOLDER}	Soldering Temperature·Time	260·10	°C·sec	1
P _D	Power Dissipation	600	mW	1
I _{OUT}	Short Circuit Output Current	50	mA	1

DC RECOMMENDED OPERATING CONDITIONS (T_a=0~70°C)

SYMBOL	ITEM	MIN.	TYP.	MAX.	UNIT	NOTE
V _{DD}	Power Supply Voltage	4.5	5.0	5.5	V	2
V _{IH}	Input High Voltage	2.4	-	6.5	V	2
V _{IL}	Input Low Voltage	-1.0	-	0.8	V	2

DC ELECTRICAL CHARACTERISTICS (V_{DD}=5V±10%, T_a=0~70°C)

SYMBOL	PARAMETER	PERIOD	MIN.	MAX.	UNITS	NOTES
I _{DDO}	Operating Current (Average Power Supply Operating Current) CE, Address Cycling: t _{RC} =t _{RC} MIN.	135ns	-	55	mA	3,4
		160ns	-	45		
		190ns	-	40		
I _{DD1}	Standby Current 1 CE=OE/RFSH=V _{IH}	TC51832P/SP/F	-	2	mA	
		TC51832PL/SPL/FL	-	1		
I _{DD2}	Standby Current 2 CE=OE/RFSH=V _{DD} -0.2V	TC51832P/SP/F	-	1	mA	
		TC51832PL/SPL/FL	-	100		
I _{DDF}	Self Refresh Current CE=V _{DD} -0.2V, OE/RFSH=0.2V	TC51832P/SP/F	-	1	mA	
		TC51832PL/SPL/FL	-	100		
I _{I(L)}	Input Leakage Current 0V ≤ V _{IN} ≤ V _{DD} , All other inputs not under test=0V		-10	10	μA	
I _{O(L)}	Output Leakage Current Output Disable, 0V ≤ V _{OUT} ≤ V _{DD}		-10	10	μA	
V _{OH}	Output High Level I _{OUT} =-5mA		2.4	-	V	
V _{OL}	Output Low Level I _{OUT} =4.2mA		-	0.4	V	

TOSHIBA (LOGIC/MEMORY)

T-46-23-14

ELECTRICAL CHARACTERISTICS AND RECOMMENDED AC OPERATING CONDITIONS

(V_{DD}=5V±10%, T_a=0~70°C) (NOTES:5,6,7,8,9)

SYMBOL	PARAMETER	-85		-10		-12		UNITS	NOTES
		MIN.	MAX.	MIN.	MAX.	MIN.	MAX.		
t _{RC}	Random Read or Write Cycle Time	135	-	160	-	190	-	ns	
t _{RMW}	Read Modify Write Cycle Time	200	-	240	-	280	-	ns	
t _{CE}	\overline{CE} Pulse Width	85	10,000	100	10,000	120	10,000	ns	
t _p	\overline{CE} Precharge Time	40	-	50	-	60	-	ns	
t _{CEA}	\overline{CE} Access Time	-	85	-	100	-	120	ns	
t _{OEA}	\overline{OE} Access Time	-	35	-	40	-	50	ns	
t _{CLZ}	\overline{CE} to Output in Low-Z	10	-	10	-	10	-	ns	
t _{OLZ}	\overline{OE} to Output in Low-Z	0	-	0	-	0	-	ns	
t _{WLZ}	Output Active from End of Write Enable	0	-	0	-	0	-	ns	
t _{CHZ}	Chip Disable to Output in High-Z	0	25	0	30	0	35	ns	10
t _{OHZ}	\overline{OE} Disable to Output in High-Z	0	25	0	30	0	35	ns	10
t _{WHZ}	Write Enable to Output in High-Z	0	25	0	30	0	35	ns	10
t _{OHC}	\overline{OE} Hold Time Referenced to \overline{CE}	0	-	0	-	0	-	ns	
t _{OSC}	\overline{OE} Set-Up Time Referenced to \overline{CE}	10	-	10	-	10	-	ns	
t _{RCS}	Read Command Set-Up Time	0	-	0	-	0	-	ns	
t _{RCH}	Read Command Hold Time	0	-	0	-	0	-	ns	
t _{WP}	Write Pulse Width	60	-	70	-	85	-	ns	
t _{WCH}	Write Command Hold Time	60	-	70	-	85	-	ns	
t _{CWL}	Write Command to \overline{CE} Lead Time	60	-	70	-	85	-	ns	
t _{DSW}	Data Set-Up Time Referenced to R/W	35	-	40	-	50	-	ns	11
t _{DSC}	Data Set-Up Time Referenced to \overline{CE}	35	-	40	-	50	-	ns	11
t _{DHW}	Data Hold Time Referenced to R/W	0	-	0	-	0	-	ns	11
t _{DHC}	Data Hold Time Referenced to \overline{CE}	0	-	0	-	0	-	ns	11
t _{ASC}	Address Set-Up Time	0	-	0	-	0	-	ns	12
t _{AHC}	Address Hold Time	20	-	25	-	30	-	ns	12
t _{FC}	Auto Refresh Cycle Time	135	-	160	-	190	-	ns	
t _{RFD}	\overline{CE} to RFSH Delay Time	40	-	50	-	60	-	ns	
t _{FAP}	RFSH Pulse Width (Auto Refresh)	80	8,000	80	8,000	80	8,000	ns	13
t _{FP}	RFSH Precharge Time	30	-	30	-	30	-	ns	13
t _{FCE}	RFSH to \overline{CE} Active Delay Time	160	-	190	-	225	-	ns	13
t _{FAS}	RFSH Pulse Width (Self Refresh)	8000	-	8,000	-	8,000	-	ns	13
t _{FRS}	\overline{CE} Delay Time from RFSH (Self Refresh)	160	-	190	-	225	-	ns	13

T-46-23-14

(Continued)

SYMBOL	PARAMETER	-85		-10		-12		UNITS	NOTES
		MIN.	MAX.	MIN.	MAX.	MIN.	MAX.		
t _{FST}	$\overline{\text{RFSH}}$ Set-Up Time (Refresh Counter Test)	10	30	10	30	10	30	ns	
t _{FHT}	$\overline{\text{RFSH}}$ Hold Time (Refresh Counter Test)	65	8,000	65	8,000	65	8,000	ns	
t _{REF}	Refresh Period	-	4	-	4	-	4	ms	
t _T	Transition Time (Rise and Fall)	3	50	3	50	3	50	ns	

CAPACITANCE (V_{DD}=5V, f=1MHz, Ta=25°C)

SYMBOL	PARAMETER	MIN.	MAX.	UNITS
C _{I1}	Input Capacitance (A0 ~ A14)	-	5	pF
C _{I2}	Input Capacitance ($\overline{\text{CE}}$, $\overline{\text{OE}}$ / $\overline{\text{RFSH}}$, R/W)	-	7	pF
C _{IO}	Input/Output Capacitance (I/O1 ~ I/O8)	-	7	pF

NOTE) This parameter is periodically sampled and is not 100% tested.

NOTES:

- 1) Stresses greater than those listed under "Absolute Maximum Ratings" may cause permanent damage to the device.
- 2) All voltages are referenced to GND.
- 3) IDDO depends on cycle rate.
- 4) IDDO depends on output loading. Specified values are obtained with the output open.
- 5) An initial pause of 1ms with high \overline{CE} and high $\overline{OE}/\overline{RFSH}$ are required after power-up, before proper device operation is achieved.
- 6) AC measurements assume $t_T=5ns$.
- 7) $V_{IH}(min.)$ and $V_{IL}(max.)$ are reference levels for measuring timing of input signals. Also, transition times are measured between V_{IH} and V_{IL} .
- 8) Measured with a load equivalent to 2 TTL loads and 100pF.
- 9) The $\overline{OE}/\overline{RFSH}$ input operates as the output enable input (\overline{OE}) and refresh control input (\overline{RFSH}) under the condition of that $\overline{CE}=V_{IL}$ and $\overline{CE}=V_{IH}$, respectively.
- 10) t_{CHZ} , t_{OHZ} , t_{WHZ} define the time at which the output achieves the open circuit condition and is not referenced to output voltage levels.
- 11) In write cycles, the input data is latched at the earlier of R/W or \overline{CE} rising edge. Therefore the input data must be valid during set-up time (t_{DSW} , t_{DSC}) and hold time (t_{DHW} , t_{DHC}).
- 12) All address inputs are latched at the falling edge of \overline{CE} . Therefore all the address inputs must be valid during t_{ASC} and t_{AHC} .
- 13) Two refresh operation - auto refresh and self refresh are defined by the $\overline{OE}/\overline{RFSH}$ pulse width under the condition of $\overline{CE}=V_{IH}$.

Auto refresh: $\overline{OE}/\overline{RFSH}$ pulse width $\leq t_{FAP}$ (max.)
Self refresh: $\overline{OE}/\overline{RFSH}$ pulse width $\geq t_{FAS}$ (min.)

The following timing parameter must be kept for proper device operation after refresh

Auto refresh: t_{FCE}
Self refresh: t_{FRS}

T-46-23-14

TIMING CHART

READ CYCLE

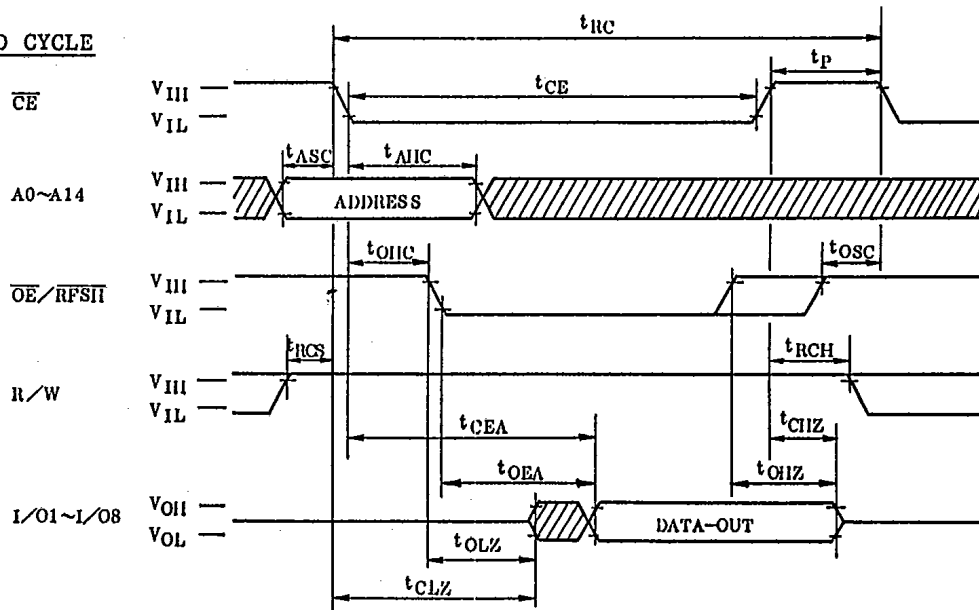

WRITE CYCLE

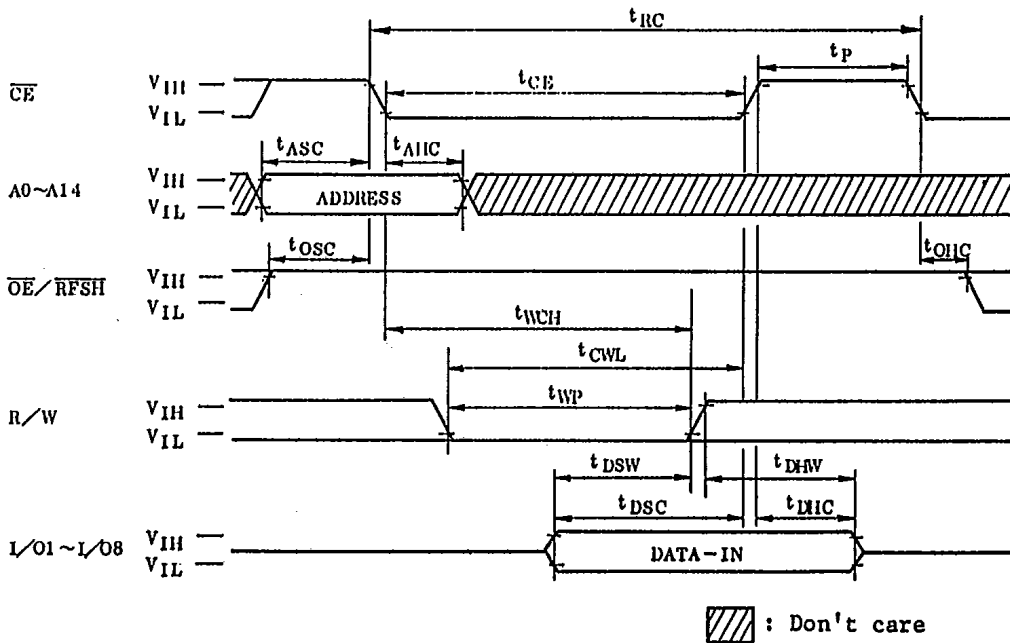

READ MODIFY WRITE CYCLE

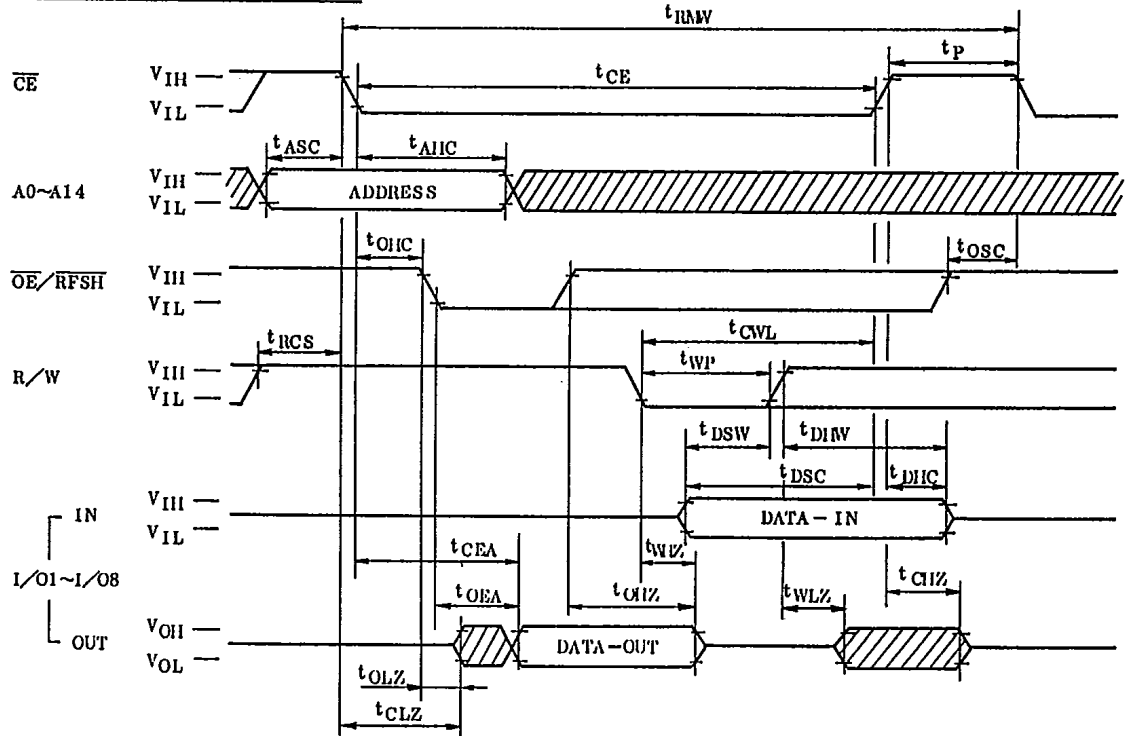

\overline{CE} ONLY REFRESH CYCLE

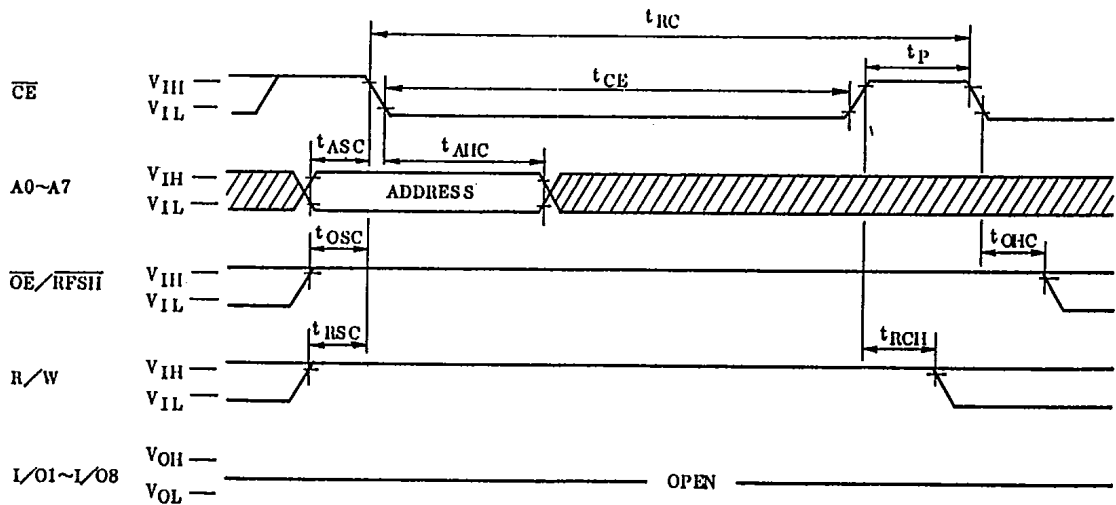

▨ : Don't care

AUTO REFRESH CYCLE

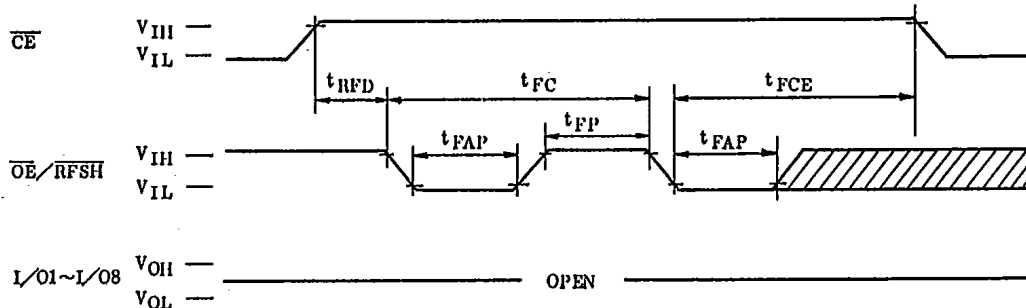

Note) A0 ~ A14, R/W=Don't care ▨: Don't care

SELF REFRESH CYCLE

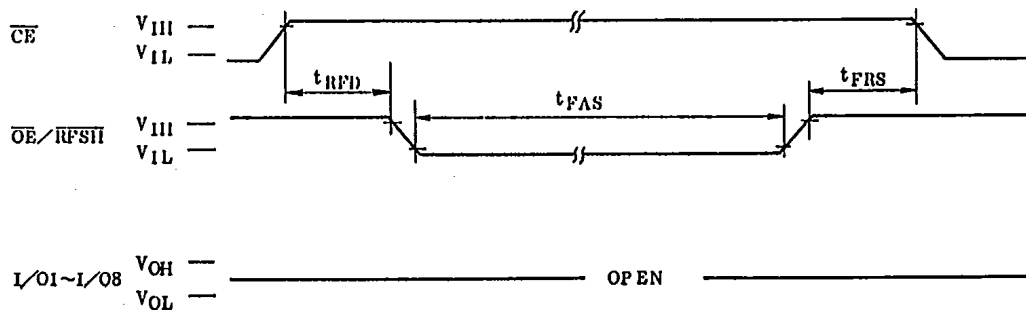

Note) A0 ~ A14, R/W=Don't care

T-46-23-14

REFRESH COUNTER TEST CYCLE (READ WRITE)

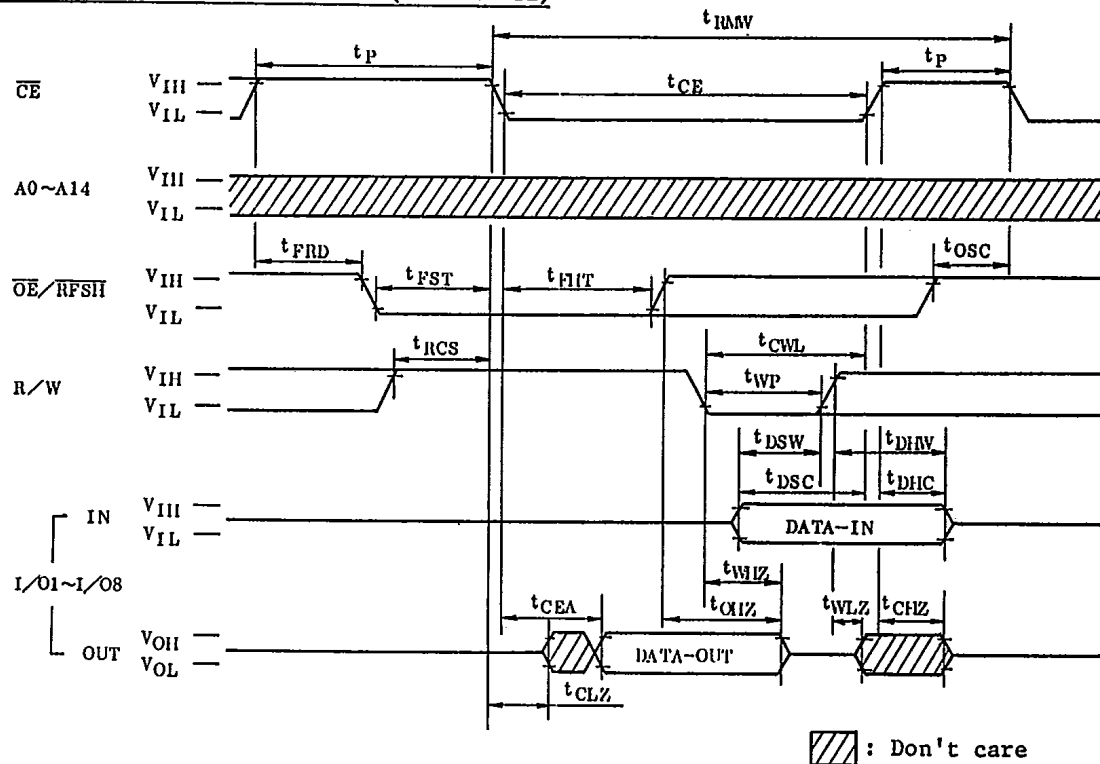

REFRESH COUNTER TEST

The internal refresh operation of TC51832P family can be tested by REFRESH COUNTER TEST. This cycle performs READ/WRITE operation taking the internal counter address as row address and fixed zero as column address.

The test procedure is as follows.

- ① Write "0" into all the memory cells at normal write mode.
- ② Read "0" out and write "1" in each cell by performing REFRESH COUNTER TEST. Repeat this operation 256 times.
- ③ Check "1" out of 256 bits at normal read mode, which was written at ②.
- ④ Read "1" out and write "0" in each cell by performing REFRESH COUNTER TEST. Repeat this operation 256 times.
- ⑤ Check "0" out of 256 bits at normal read mode, which was written at ④.
- ⑥ Perform the above ① to ⑤ the complement data.

TC51832P/SP/F/PL/SPL/FL-85

TC51832P/SP/F/PL/SPL/FL-10

TC51832P/SP/F/PL/SPL/FL-12

T-46-23-14

OUTLINE DRAWINGS (DIP28-P-600)

Unit in mm

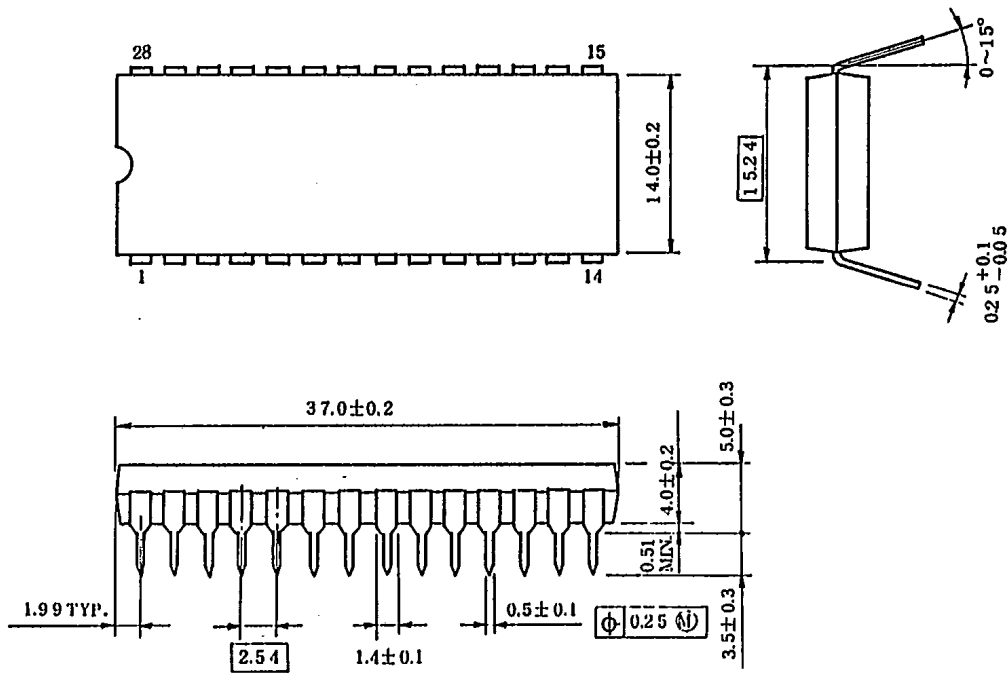

NOTES: Package width and length do not include mold protrusion, allowable mold protrusion is 0.15mm.

These outline drawings apply to:

TC51832P-85, TC51832PL-85
 TC51832P-10, TC51832PL-10
 TC51832P-12, TC51832PL-12

T-46-23-14

OUTLINE DRAWINGS (DIP28-P-300)

Unit in mm

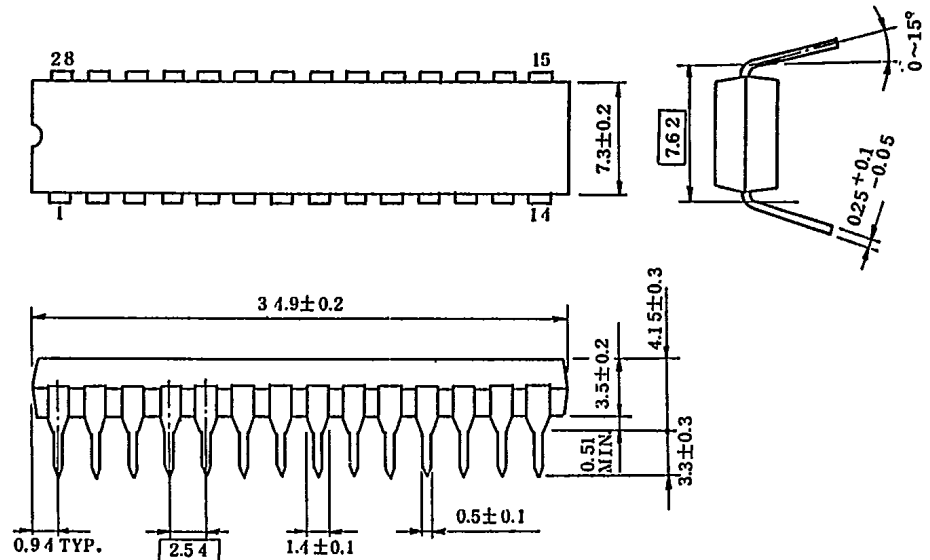

Note: Package width and length do not include mold protrusion,
allowable mold protrusion is 0.15mm.

These outline drawings apply to:

TC51832SP-85, TC51832SPL-85

TC51832SP-10, TC51832SPL-10

TC51832SP-12, TC51832SPL-12

OUTLINE DRAWINGS (SOP28-P-450)

Unit in mm

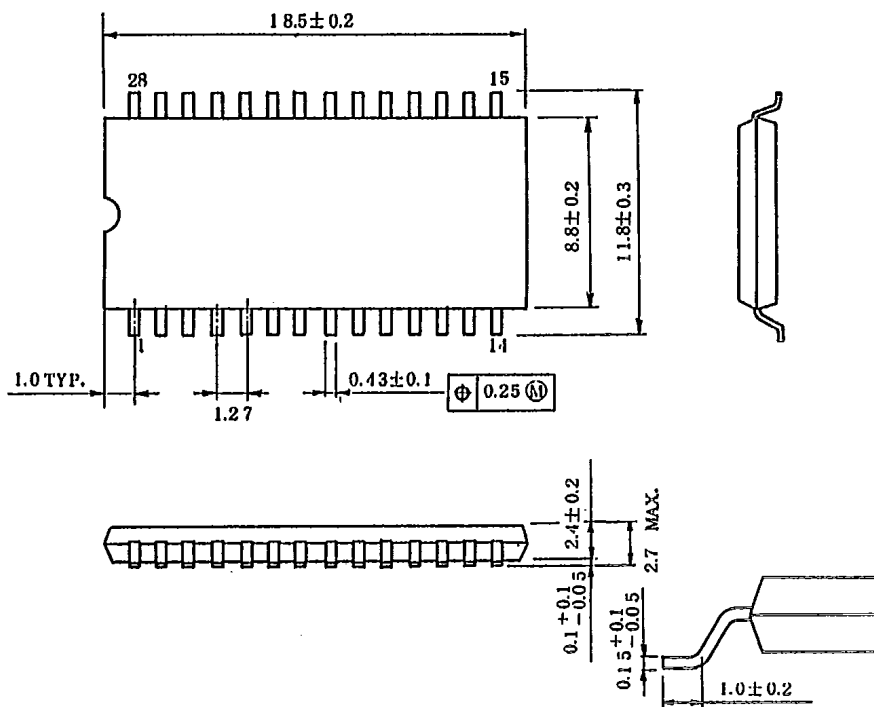

Note: Package width and length do not include mold protrusion, allowable mold protrusion is 0.15mm.

These outline drawings apply to:

- TC51832F-85, TC51832FL-85
- TC51832F-10, TC51832FL-10
- TC51832F-12, TC51832FL-12