

Expanded Decoder for Program Delivery Control and Video Program System EPDC / VPS Decoder

SDA 5649
SDA 5649X

CMOS IC

Features

- Single-chip receiver for PDC data, broadcast either
 - in Broadcast Data Service Packet (BDSP) 8/30/2 according to CCIR teletext system B, or
 - in dedicated line no. 16 of the vertical blanking interval (VPS)
- Reception of Unified Date and Time (UDT), Network Identification code (NIC), and Short Program Label (SPL) broadcast in BDSP 8/30/1
- Reception of bytes no.38 through 45 of teletext header row containing clock time
- Low external components count
- On-chip data and sync slicer
- I²C-Bus interface for communication with external microcontroller
- Selection of PDC/VPS operating mode software controlled by I²C-Bus register
- Pin and software compatible to PDC/VPS Decoder SDA 5648
- Supply voltage: 5 V ± 10 %
- Video input signal level: 0.7 V_{pp} to 1.4 V_{pp}
- Technology: CMOS
- Package: P-DIP-14-3 and P-DSO-20-1
- Operating temperature range: 0 to 70 °C

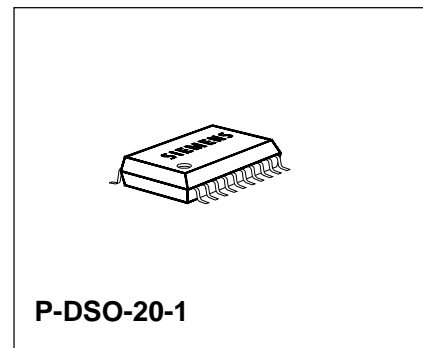
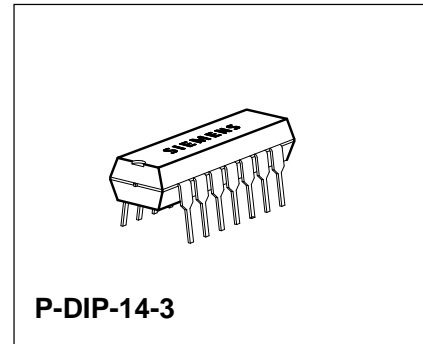

Type	Ordering Code	Package
SDA 5649	Q67100-H5156	P-DIP-14-3
SDA 5649X	Q67106-H5157	P-DSO-20-1 Tape & Reel

Functional Description

The CMOS circuit SDA 5649 is intended for use in video cassette recorders to retrieve control data of the PDC system from the data lines broadcast during the vertical blanking interval of a standard video signal.

The SDA 5649 is devised to handle PDC data transported either in Broadcast Data Service Packet (BDSP) 8/30 format 2 (bytes no. 13 through 25) of CCIR teletext system B or in the dedicated data line no. 16 in the case of VPS.

Furthermore it is able to receive the Unified Date and Time (UDT) information transmitted in bytes no. 15 through 21, the Network Identification code (NIC) carried in bytes no. 13 and 14, and the Short Program Label carried in bytes no. 22 through 25 of packet 8/30 format 1.

For reception of clock time when no BDSP 8/30/1 is present the SDA 5649 can be enabled to extract bytes no. 38 through 45 of the teletext header row.

All operating modes (PDC/VPS) are selected by a control register which can be written to via the I²C-Bus interface.

Pin Configuration

(top view)

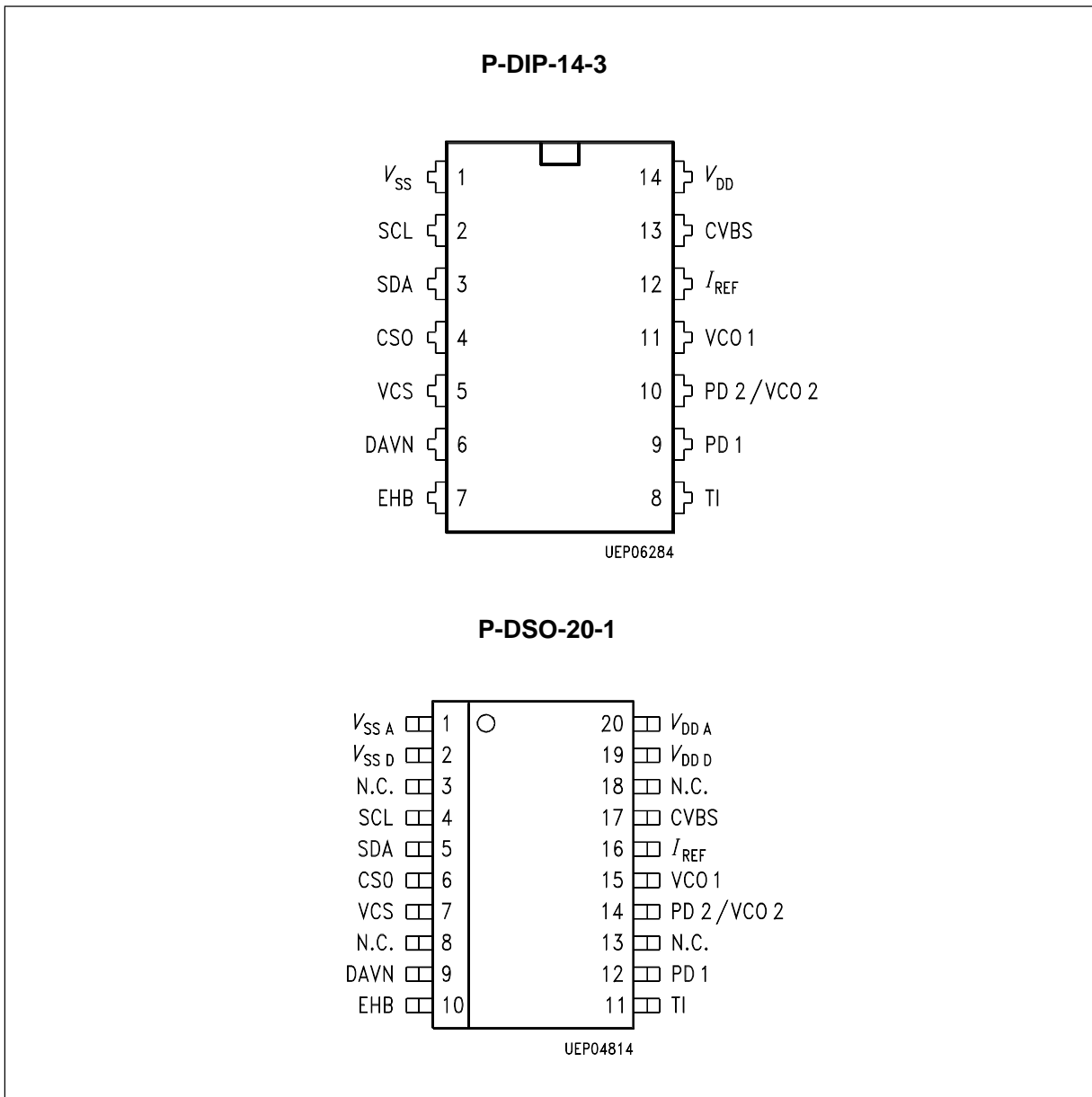

Pin Definitions and Functions

Pin No. P-DIP-14-3	Pin No. P-DSO-20-1	Symbol	Function
1		V_{SS}	Ground (0 V)
	1	V_{SSA}	Analog ground (0 V)
	2	V_{SSD}	Digital ground (0 V)
	3	N.C.	Not connected
2	4	SCL	Serial clock input of I ² C-Bus.
3	5	SDA	Serial data input of I ² C-Bus.
4	6	CS0	Chip select input determining the I ² C-Bus addresses: 20 _H / 21 _H , when pulled low 22 _H / 23 _H , when pulled high.
5	7	VCS	Video Composite Sync output from sync slicer used for PLL based clock generation.
	8	N.C.	Not connected
6	9	DAVN	Data available output active low, when PDC/VPS data is received.
7	10	EHB	Output signaling the presence of the first field active high.
8	11	TI	Test input; activates test mode when pulled high. connect to ground for operating mode.
9	12	PD1	Phase detector/charge pump output of data PLL (DAPLL).
	13	N.C.	Not connected
10	14	PD2/ VCO2	Connector of the loop filter for the SYSPLL.
11	15	VCO1	Input to the voltage controlled oscillator #1 of the DAPLL.
12	16	I_{REF}	Reference current input for the on-chip analog circuit.
13	17	CVBS	Composite video signal input.
	18	N.C.	Not connected
14		V_{DD}	Positive supply voltage (+ 5 V nom.).
	19	V_{DDD}	Positive supply voltage for the digital circuits (+ 5 V nom.).
	20	V_{DDA}	Positive supply voltage for the analog circuits (+ 5 V nom.).

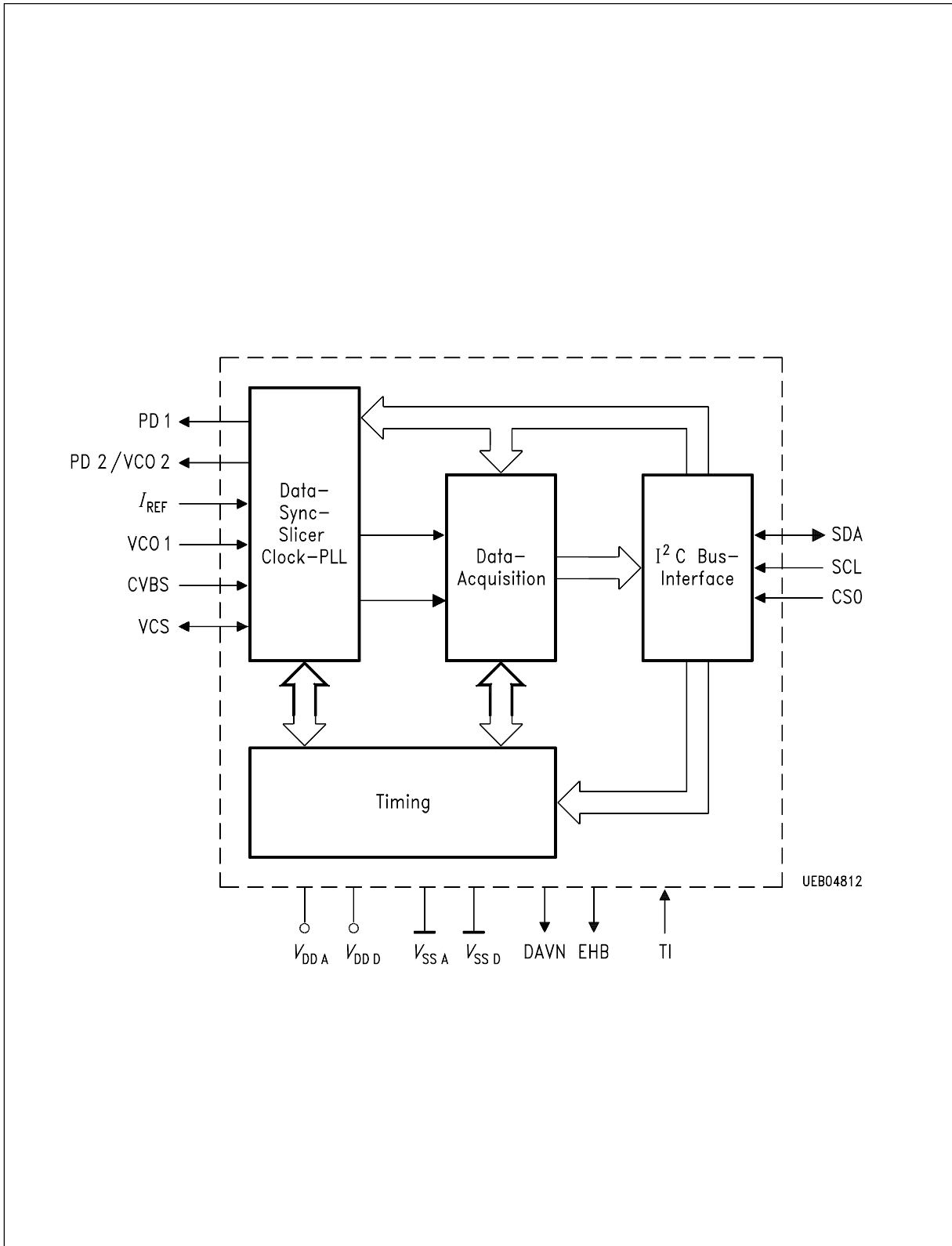

Block Diagram

Circuit Description

Referring to the functional block diagram of the PDC / VPS decoder, the composite video signal with negative going sync pulses is coupled to the pin CVBS through a capacitor which is used for clamping the bottom of the sync pulses to an internally fixed level. The signal is passed on to the slicer, an analogue circuitry separating the sync and the data parts of the CVBS signal, thus yielding the digital composite sync signal VCS and a digital data signal for further processing by comparing those signals to internally generated slicing levels.

The output of the sync separator is forwarded, on one hand, to the output pin VCS, and on the other hand, to the clock generator and the Timing block. The VCS signal represents a key signal that is used for deriving a system clock signal by means of a PLL and all other timing signal.

The output of the sync separator is forwarded, on one hand, to the output pin VCS, and on the other hand, to the clock generator and the Timing block. The VCS signal represents a key signal that is used for deriving a system clock signal by means of a PLL and all other timing signal.

The data slicer separates the data signal from the CVBS signal by comparing the video voltage to an internally generated slicing level which is found by averaging the data signal during TV line no. 16 in the VPS mode or by averaging the data signal during the clock run-in period of the teletext lines during the data entry window (DEW) in PDC mode.

The clock generator delivers the system clock needed for the basic timing as well as for the regeneration of the dataclock. It is based on two phase locked loops (PLL's) all parts of which are integrated on chip with the exception of the loop filter components. Each of the PLL's is composed of a voltage controlled relaxation oscillator (VCO), a phase/frequency detector (PFD), and a charge pump which converts the digital output signals of the PFD to an analogue current. That current is transformed to a control voltage for the VCO by the off-chip loop filter. The generated VCO frequencies are 10 MHz and 13.875 MHz for VPS mode and PDC mode, respectively.

All signals necessary for the control of sync and data slicing as well as for the data acquisition are generated by the Timing block.

Depending on the selected operating mode, either teletext lines carrying 8/30 packages or the dedicated TV line no. 16 are acquired.

In PDC mode, only teletext rows 8/30 containing Broadcast Data Service Package (BDSP) information are acquired. The relevant bytes of 8/30 format 1 (8/30/1) and 8/30 format 2 (8/30/2) are extracted. The 8/30/1-bytes are stored in the acquisition register in a transparent way without any bit manipulation, whereas the Hamming coded bytes of packet 8/30/2 are Hamming-checked and bytes with one bit error are corrected. The storage of error free or corrected 8/30/2-data bytes in the transfer register to the I²C-Bus is signalled by the DAVN output going low.

In VPS mode, the extracted data bits of TV line no. 16 are checked for biphasic errors. With no biphasic errors encountered, the acquired bytes are stored in the transfer register to the I²C-Bus. That transfer is signalled by a H/L transition of the DAVN output, as well.

In both operating modes data are updated when a new data line has been received, provided that the chip is not accessed via the I²C-Bus at the same time.

A micro controller can read the stored bytes via the I²C-Bus interface at any time. However, one must be aware that the storage of new data from the acquisition interface is inhibited as long as the PDC decoder is being accessed via the I²C-Bus.

I²C-Bus

General Information

The I²C-Bus interface implemented on the PDC decoder is a slave transmitter/receiver, i.e., both reading from and writing to the PDC / VPS decoder is possible. The clock line SCL is controlled only by the bus master usually being a micro controller, whereas the SDA line is controlled either by the master or by the slave. A data transfer can only be initiated by the bus master when the bus is free, i.e., both SDA and SCL lines are in a high state. As a general rule for the I²C-Bus, the SDA line changes state only when the SCL line is low. The only exception to that rule are the Start Condition and the Stop Condition. Further Details are given below. The following abbreviations are used:

START : Start Condition generated by master
 AS : Acknowledge by slave
 AM : Acknowledge by master
 NAM : No Acknowledge by master
 STOP : Stop Condition generated by master

Chip Address

There are two pairs of chip addresses, which are selected by the CS0-input pin according to the following table:

CS0 Input	Write Mode	Read Mode
Low	20 (hex)	21 (hex)
High	22 (hex)	23 (hex)

Write Mode

For writing to the PDC decoder, the following format has to be used.

START	Chipadress Write Mode	AS	Byte Set Control Register	AS	STOP
-------	-----------------------	----	---------------------------	----	------

Data Transfer (Write Mode)

Step 1: In order to start a data transfer the master generates a Start Condition on the bus by pulling the SDA line low while the SCL line is held high.

Step 2: The bus master puts the chip address on the SDA line during the next eight SCL pulses.

Step 3: The master releases the SDA line during the ninth clock pulse. Thus the slave can generate an acknowledge (AS) by pulling the SDA line to a low level.

Step 4: The controller transmits the data byte to set the Control register.

Step 5: The slave acknowledges the reception of the byte.

Step 6: The master concludes the data communication by generating a Stop Condition.

The write mode is used to set the I²C-Bus control register which determines the operating mode:

Control Register

Bit Number	7	6	5	4	3	2	1	0
	T4	T3	T2	T1	T0	HDT	PDC/ VPS	FOR1/ FOR2

Default: All bits are set to 0 on power-up.

Bits 3 through 7 are used for test purposes and must not be changed for normal operation by user software!

Bit 0: Determines, which kind of data is accessed via the I²C-Bus when PDC mode is active.

Value	
0	1
BDSP 8/ 30/ 2 data accessible	BDSP 8/ 30/ 1 or header row data accessible (refer to description of Bit 2)

Bit 1: Determines the operating mode.

Value	
0	1
VPS mode active	PDC mode active

Bit 2: Determines whether BDSP 8/30/1-data or header row data is accessible.

Value	
0	1
BDSP 8/30/1 data accessible	Bytes no.38 through 45 of the header row containing clock time accessible

Read Mode

For reading from the PDC decoder, the following format has to be used.

START	Chipaddress	Read Mode	AS	1st Byte	AM	...	Last Byte	NAM	STOP
-------	-------------	-----------	----	----------	----	-----	-----------	-----	------

The contents of up to 13 registers (bytes) can be read starting with byte 1 bit 7 (refer to the table **Order of Data Output on the I²C-Bus and ...**) depending on the selected operating mode.

Data Transfer (Read Mode)

- Step 1:* To start a data transfer the master generates a Start Condition on the bus by pulling the SDA line low while the SCL line is held high. The byte address counter in the decoder is reset and points to the first byte to be output.
- Step 2:* The bus master puts the chip address on the SDA line during the next eight SCL pulses.
- Step 3:* The master releases the SDA line during the ninth clock pulse. Thus the slave can generate an acknowledge (AS) by pulling the SDA line to a low level. At this moment, the slave switches to transmitting mode.
- Step 4:* During the next eight clock pulses the slave puts the addressed data byte onto the SDA line.
- Step 5:* The reception of the byte is acknowledged by the master device which, in turn, pulls down the SDA line during the next SCL clock pulse. By acknowledging a byte, the master prompts the slave to increment its internal address counter and to provide the output of the next data byte.
- Step 6:* Steps no. 4 and no. 5 are repeated, until the desired amount of bytes have been read.
- Step 7:* The last byte is output by the slave since it will not be acknowledged by the master.
- Step 8:* To conclude the read operation, the master doesn't acknowledge the last byte to be received. A No Acknowledge by the master (NAM) causes the slave to switch from transmitting to receiving mode. Note that the master can prematurely cease any reading operation by not acknowledging a byte.
- Step 9:* The master gains control over the SDA line and concludes the data transfer by generating a Stop Condition on the bus, i. e., by producing a low/high transition on the SDA line while the SCL line is in a high state. With the SDA and the SCL lines being both in a high state, the I²C-Bus is free and ready for another data transfer to be started.

Order of Data Output on the I²C-Bus and Bit Allocation of the 3 Different Operating Modes

I ² C-Bus		PDC Packet 8/30				VPS Mode		
		Format 1		Format 2				
t ↓	Byte 1	bit 7	byte 15	bit 0 ²⁾	byte 16	bit 0 ¹⁾	byte 11	bit 0 ²⁾
		6		1		1		1
		5		2		2		2
		4		3		3		3
		3		4	byte 17	bit 0		4
		2		5		1		5
		1		6		2		6
		0		7		3		7
	Byte 2	bit 7	byte 16	bit 0	byte 18	bit 0	byte 12	bit 0
		6		1		1		1
		5		2		2		2
		4		3		3		3
		3		4	byte 19	bit 0		4
		2		5		1		5
		1		6		2		6
		0		7		3		7
	Byte 3	bit 7	byte 17	bit 0	byte 20	bit 0	byte 13	bit 0
		6		1		1		1
		5		2		2		2
		4		3		3		3
		3		4	byte 21	bit 0		4
		2		5		1		5
		1		6		2		6
		0		7		3		7
	Byte 4	bit 7	byte 18	bit 0	byte 22	bit 0	byte 14	bit 0
		6		1		1		1
		5		2		2		2
		4		3		3		3
		3		4	byte 23	bit 0		4
		2		5		1		5
		1		6		2		6
		0		7		3		7

1) Message bit numbers according to EBU specification of PDC system.

2) Transmission bit number

Order of Data Output on the I²C-Bus and Bit Allocation of the 3 Different Operating Modes
(cont'd)

I ² C-Bus		PDC Packet 8/30				VPS Mode			
		Format 1		Format 2					
Byte 5	bit 7	byte 19	bit 0	byte 14	bit 0	byte 5	bit 0		
	6		1		1		1		
	5		2		2		2		
	4		3		3		3		
	3		4		byte 15		bit 0	4	4
	2		5					1	5
	1		6					2	6
	0		7					3	7
Byte 6	bit 7	byte 20	bit 0	byte 24	bit 0	byte 15	bit 0		
	6		1		1		1		
	5		2		2		2		
	4		3		3		3		
	3		4		byte 25		bit 0	4	4
	2		5					1	5
	1		6					2	6
	0		7					3	7
Byte 7	bit 7	byte 21	bit 0	byte 13	bit 0	– set to “1”			
	6		1		1	– set to “1”			
	5		2		2	– set to “1”			
	4		3		3	– set to “1”			
	3		4		– set to “1”	– set to “1”	4	– set to “1”	
	2		5				– set to “1”	– set to “1”	
	1		6				– set to “1”	– set to “1”	
	0		7				– set to “1”	– set to “1”	
Byte 8	bit7	byte 13	bit 0						
	6		1						
	5		2						
	4		3						
	3		4						
	2		5						
	1		6						
	0		7						
Byte 9	bit7	byte 14	bit 0						
	6		1						
	5		2						
	4		3						
	3		4						
	2		5						
	1		6						
	0		7						

I ² C-Bus		PDC Packet 8/30		VPS Mode
		Format 1	Format 2	
Byte 10	bit7 6 5 4 3 2 1 0	byte 22	bit 0 1 2 3 4 5 6 7	
Byte 11	bit7 6 5 4 3 2 1 0	byte 23	bit 0 1 2 3 4 5 6 7	
Byte 12	bit7 6 5 4 3 2 1 0	byte 24	bit 0 1 2 3 4 5 6 7	
Byte 13	bit7 6 5 4 3 2 1 0	byte 25	bit 0 1 2 3 4 5 6 7	

Order of Data Output on the I²C-Bus and Bit Allocation for the Header Time Mode

I ² C-Bus		Header Time Mode		
t ↓	Byte 1	bit 7	byte 38	bit 0 ²⁾
		6		1
		5		2
		4		3
		3		4
		2		5
		1		6
		0		7
Byte 2	bit 7	byte 39	bit 0	
	6		1	
	5		2	
	4		3	
	3		4	
	2		5	
	1		6	
	0		7	
Byte 3	bit 7	byte 40	bit 0	
	6		1	
	5		2	
	4		3	
	3		4	
	2		5	
	1		6	
	0		7	
Byte 4	bit 7	byte 41	bit 0	
	6		1	
	5		2	
	4		3	
	3		4	
	2		5	
	1		6	
	0		7	

- 1) Message bit numbers according to EBU specification of PDC system.
- 2) Transmission bit number.

Order of Data Output on the I²C-Bus and Bit Allocation for the Header Time Mode
(cont'd)

I ² C-Bus		Header Time Mode		
t ↓	Byte 5	bit 7	byte 42	bit 0 ²⁾
		6		1
		5		2
		4		3
		3		4
		2		5
		1		6
		0		7
	Byte 6	bit 7	byte 43	bit 0
		6		1
		5		2
		4		3
		3		4
		2		5
		1		6
		0		7
	Byte 7	bit 7	byte 44	bit 0
		6		1
		5		2
		4		3
		3		4
		2		5
		1		6
		0		7
	Byte 8	bit 7	byte 45	bit 0
		6		1
		5		2
		4		3
		3		4
		2		5
		1		6
		0		7

1) Message bit numbers according to EBU specification of PDC system.
2) Transmission bit number

Description of DAVN and EHB Outputs

DAVN (Data Valid active low)

EHB (First Field active high)

Signal Output	VPS Mode	PDC Mode		
		8/30/2 Mode	8/30/1 Mode	Header Time
DAVN				
H/L-transition (set low)	in line 16 when valid VPS data is received	in the line carrying valid 8/30/2 data	in the line carrying valid 8/30/1 data	in the line carrying valid header row X/0 data
L/H-transition (set high)	at the start of line 16	at the beginning of the next field i.e., at the start of the next data entry window		
always set high	on power-up or during I ² C-Bus accesses when the bus master doesn't acknowledge in order to generate the stop condition			
EHB				
L/H-transition	at the beginning of the first field			
H/L-transition	at the beginning of the second field			

In test mode (i.e. TI = high), both DAVN and EHB are controlled by the CS0 pin and reproduce the state of the CS0 input.

Electrical Characteristics

Absolute Maximum Ratings

$T_A = 25\text{ °C}$

Parameter	Symbol	Limit Values			Unit	Test Condition
		min.	typ.	max.		
Ambient temperature	T_A	0		70	°C	in operation
Storage temperature	T_{stg}	- 40		125	°C	by storage
Total power dissipation	P_{tot}			300	mW	
Power dissipation per output	P_{DQ}			10	mW	
Input voltage	V_{IM}	- 0.3		6	V	
Supply voltage	V_{DD}	- 0.3		6	V	
Thermal resistance	$R_{\text{th SU}}$			80	K/W	

Operating Range

Supply voltage	V_{DD}	4.5	5	5.5	V	
Supply current	I_{DD}		5	15	mA	
Ambient temperature range	T_A	0		70	°C	

Characteristics

$T_A = 25\text{ °C}$

Parameter	Symbol	Limit Values			Unit	Test Condition
		min.	typ.	max.		

Input Signals SDA, SCL, CS0

H-input voltage	V_{IH}	$0.7 \times V_{\text{DD}}$		V_{DD}	V	
L-input voltage	V_{IL}	0		$0.3 \times V_{\text{DD}}$	V	
Input capacitance	C_{I}			10	pF	
Input current	I_{IM}			10	μA	

Input Signal TI

H-input voltage	V_{IH}	$0.9 \times V_{\text{DD}}$		V_{DD}	V	
L-input voltage	V_{IL}	0		$0.1 \times V_{\text{DD}}$	V	
Input capacitance	C_{I}			10	pF	
Input current	I_{IM}			10	μA	

Characteristics (cont'd)

$T_A = 25\text{ °C}$

Parameter	Symbol	Limit Values			Unit	Test Condition
		min.	typ.	max.		

Input Signals CVBS

(pos. Video, neg. Sync)

Video input signal level	V_{CVBS}	0.7	1.0	2.0	V	
Synchron signal amplitude	V_{SYNC}	0.15	0.3	1.0	V	
Data amplitude	V_{DAT}	0.25	0.5	1.0	V	
Coupling capacitor	C_C		33		nF	
H-input current	I_{IH}			10	μA	$V_I = 5\text{ V}$
L-input current	I_{IL}	- 1000	- 400	- 100	μA	$V_I = 0\text{ V}$
Source impedance	R_S			250	Ω	
Leakage resistance at coupling capacitor	R_C	0.91	1	1.2	M Ω	

Output Signals DAVN, EHB, VCS

H-output voltage	V_{QH}	$V_{DD} - 0.5$			V	$I_Q = - 100\ \mu\text{A}$
L-output voltage	V_{QL}			0.4	V	$I_Q = 1.6\ \text{mA}$

Output Signals SDA (Open-Drain-Stage)

L-output voltage	V_{QL}			0.4	V	$I_Q = 3.0\ \text{mA}$
Permissible output voltage				5.5	V	

PLL-Loop Filter Components (see application circuit)

Resistance at PD2/VCO2	R_1		6.8		k Ω	
Resistance at VCO1	R_2		1200		k Ω	
Attenuation resistance	R_3		6.8		k Ω	
Resistance at PD2/VCO2	R_5		1200		k Ω	
Integration capacitor	C_1		2.2		nF	
Integration capacitor	C_3		33		nF	

VCO – Frequency Range Adjustment

Resistance at IREF (for bias current adjustment)	R_4		100		k Ω	
--	-------	--	-----	--	------------	--

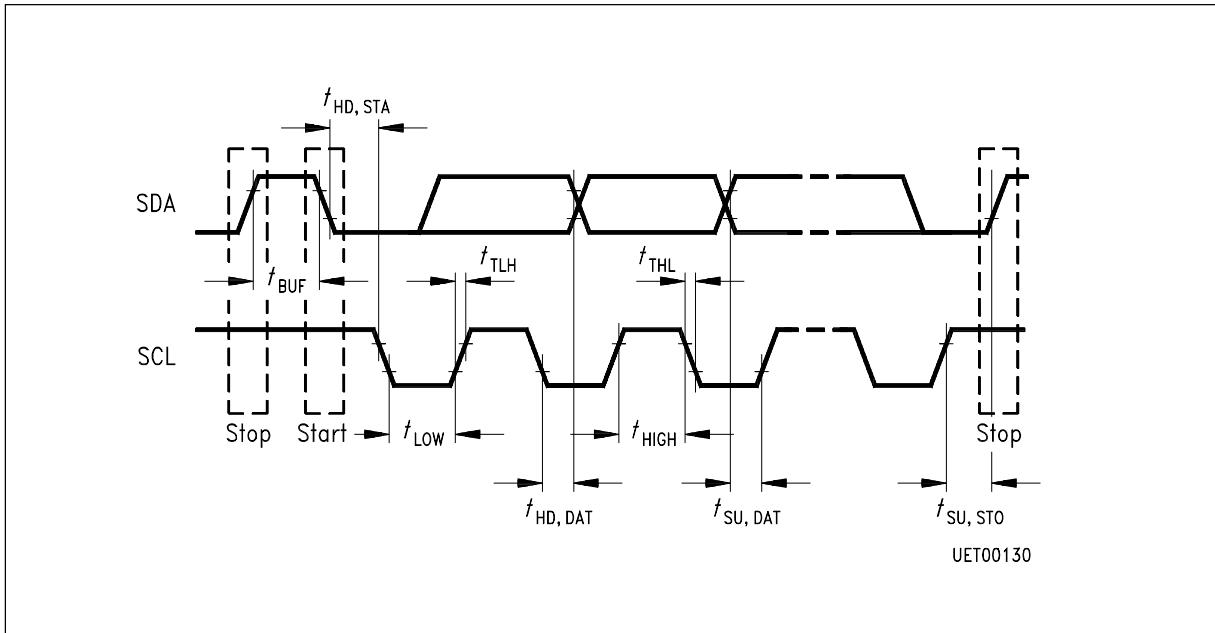

I²C-Bus Timing

Parameter	Symbol	Limit Values		Unit
		min.	max.	
Clock frequency	f_{SCL}	0	100	kHz
Inactive time prior to new transmission start-up	t_{BUF}	4.7		μ s
Hold time during start condition	$t_{HD,STA}$	4.0		μ s
Low-period of clock	t_{LOW}	4.7		μ s
High-period of clock	t_{HIGH}	4.0		μ s
Set-up time for data	$t_{SU,DAT}$	250		ns
Rise time for SDA and SCL signal	t_{TLH}		1	μ s
Fall time for SDA and SCL signal	t_{THL}		300	ns
Set-up time for SCL clock during stop condition	$t_{SU,STO}$	4.7		μ s

All values referred to V_{IH} and V_{IL} levels.

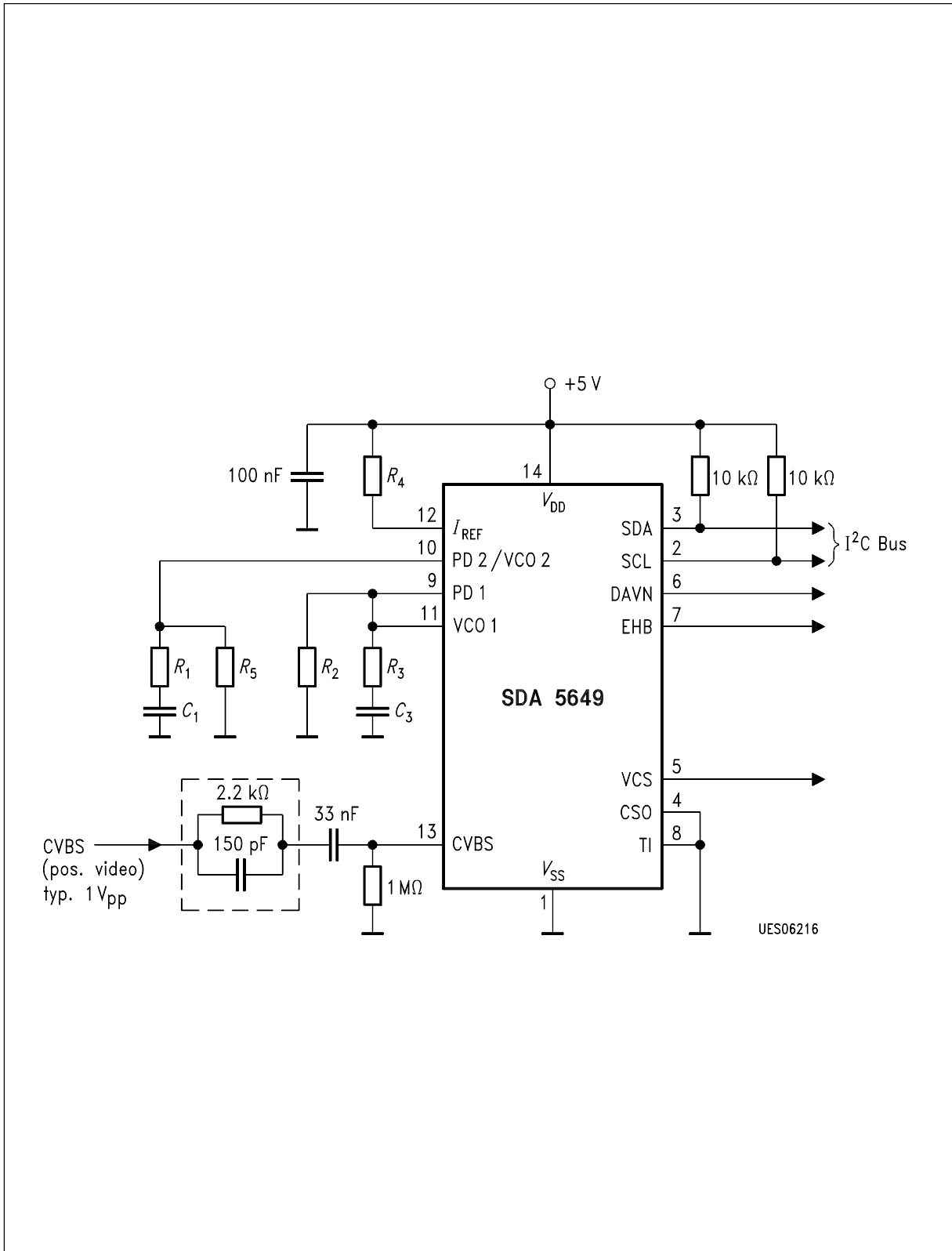

PDC/VPS-Receiver

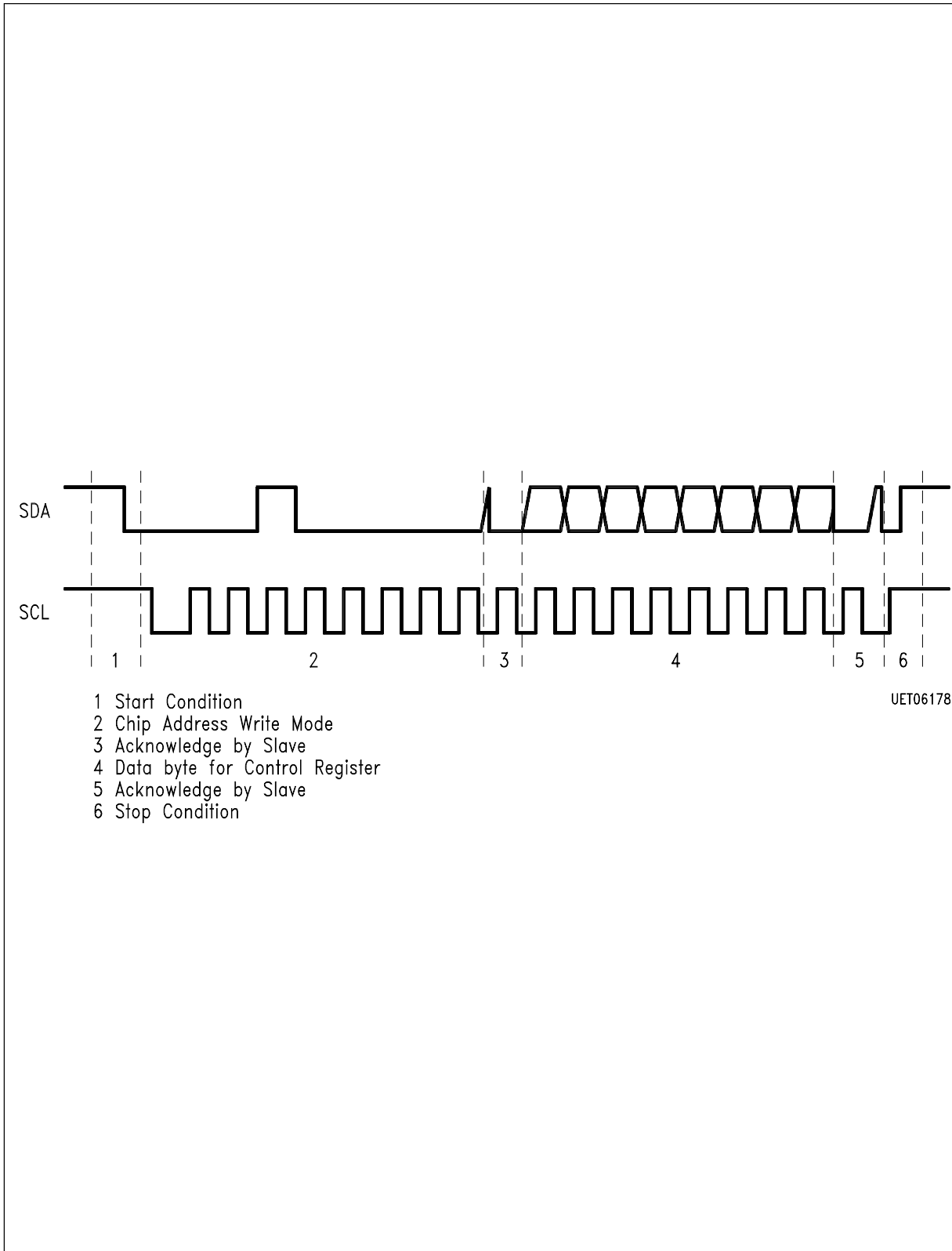

I²C-Bus Signals During Write Operations

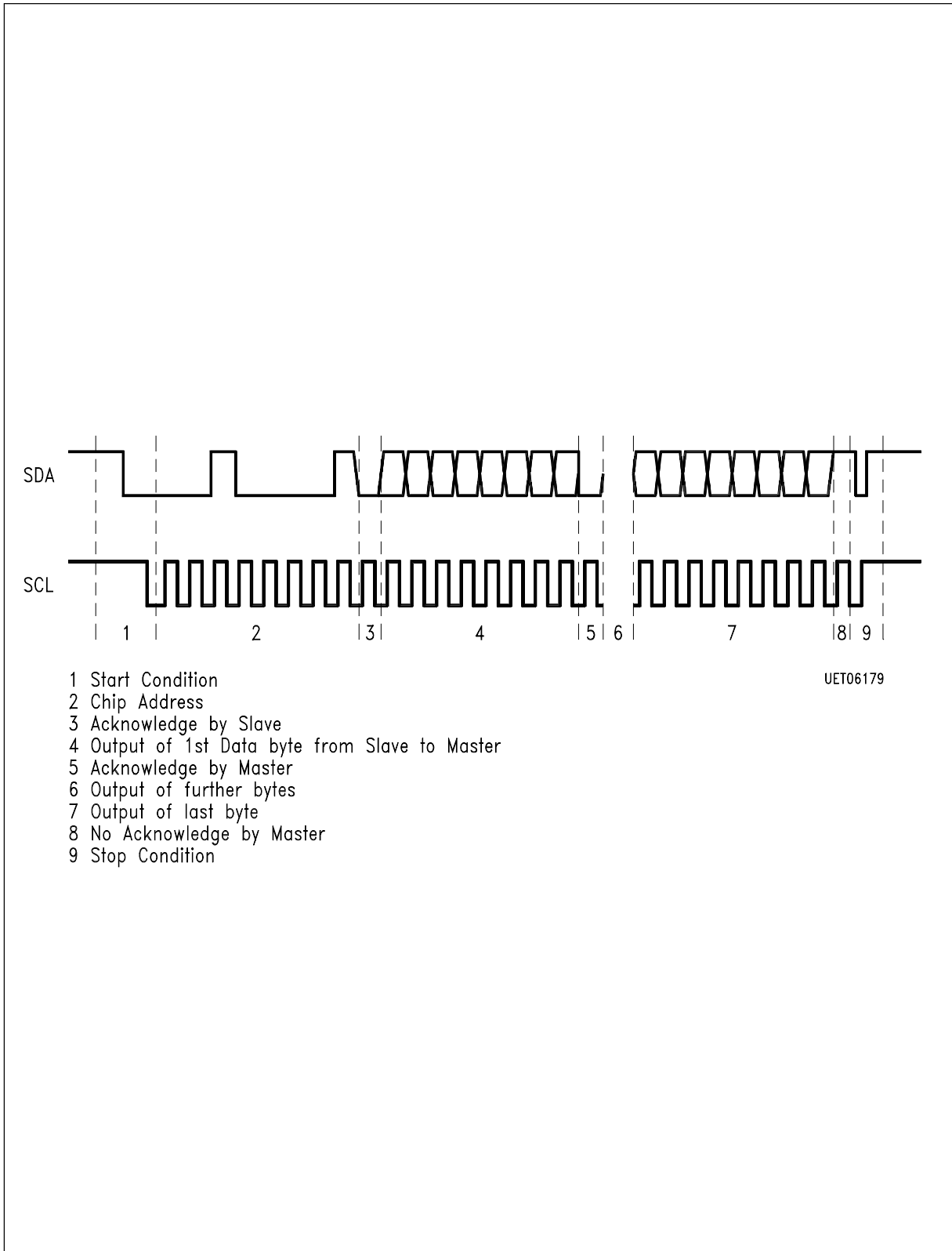

I²C-Bus Signals During Read Operations

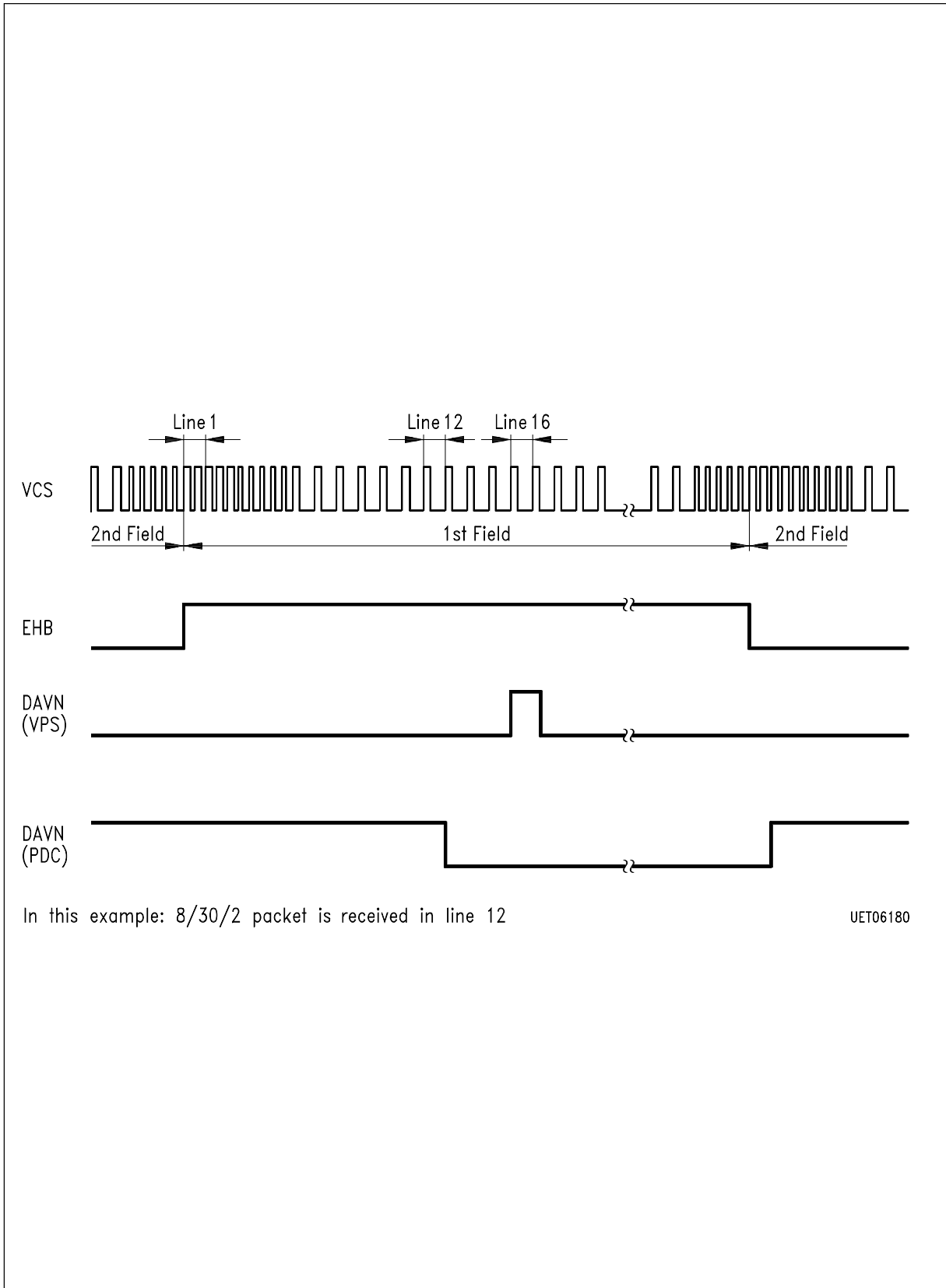

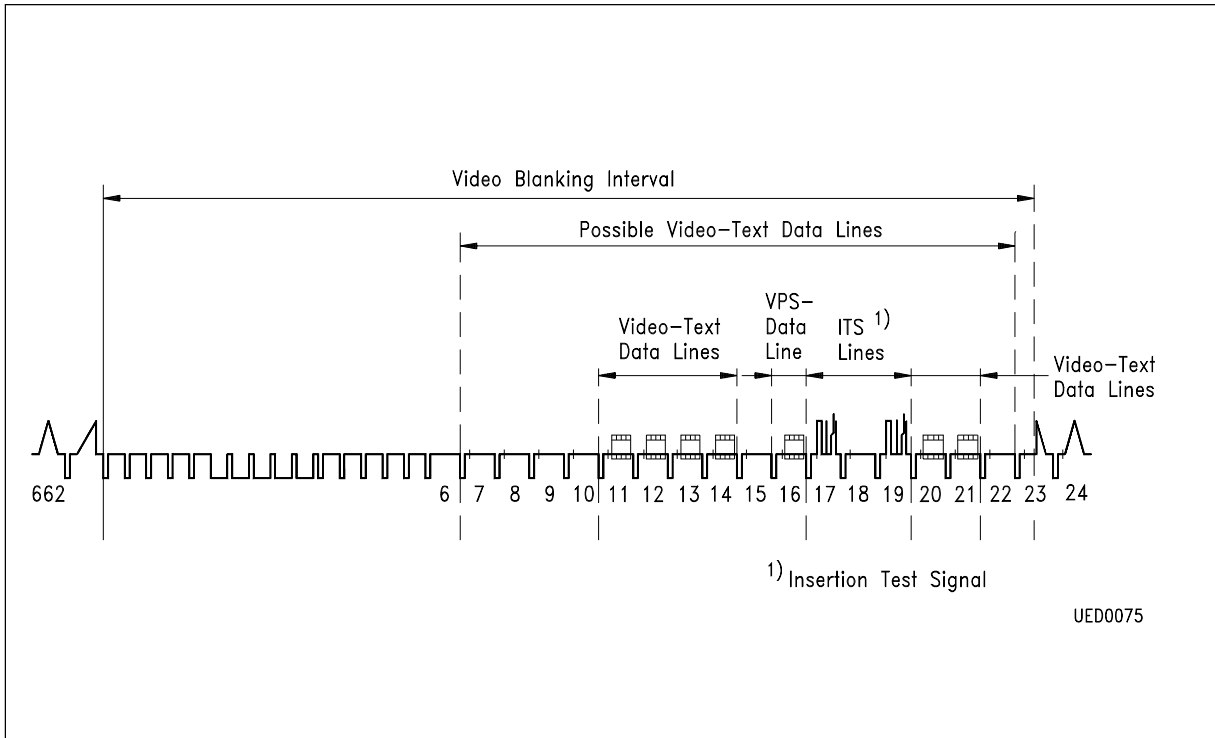

Position of Teletext and VPS Data Lines within the Vertical Blanking Interval
(shown for first field)

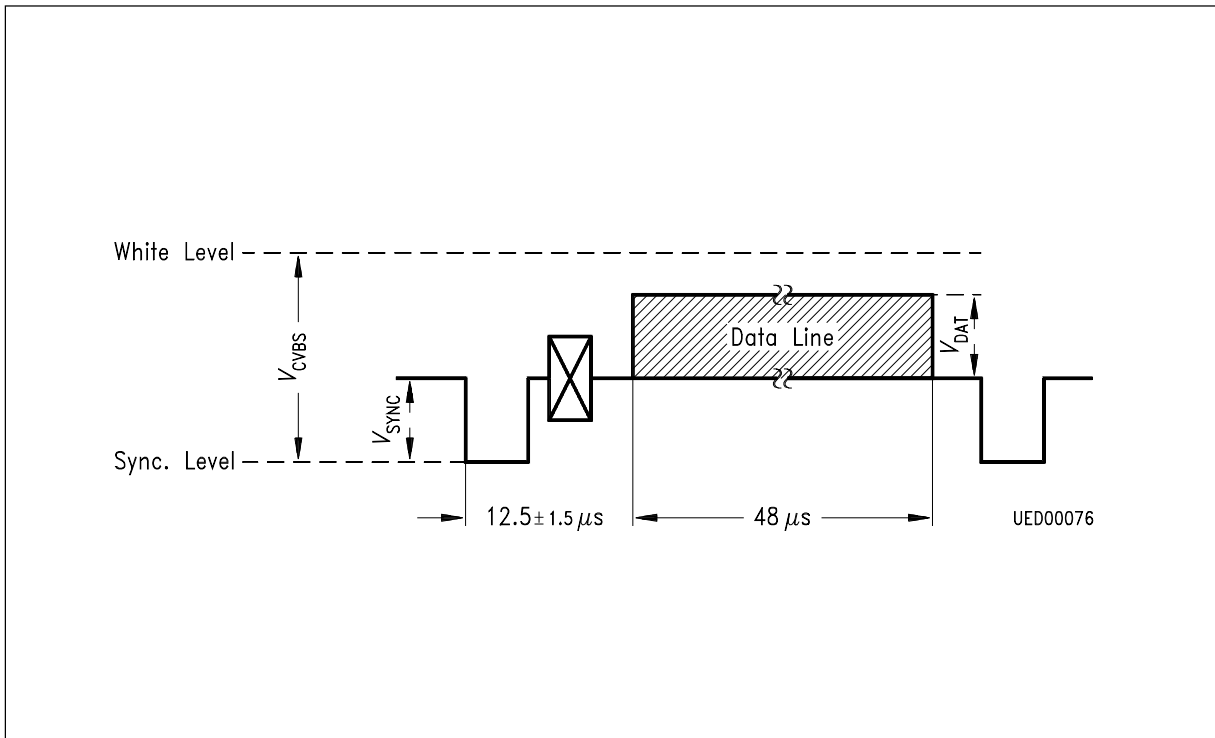

Definition of Voltage Levels for VPS Data Line

BDSP 8/30 Format 1 Bit Allocation

Byte No.	Bit No.								Contents
	0	1	2	3	4	5	6	7	
13									Network Identification 1. Byte
14									Network Identification 2. Byte
15	Weight			Weight			Sign		Time Offset Code
	2^{-2}	2^{-1}	2^0	2^1	2^2	2^3	0 1		
16	MJD Digit Weight 10^4			1	1	1	1	Modified Julian Date (MJD) 1. Byte	
17	MJD Digit Weight 10^2			MJD Digit Weight 10^3				Modified Julian Date 2. Byte	
18	MJD Digit Weight 10^0			MJD Digit Weight 10^1				Modified Julian Date (MJD) 3. Byte	
19	UTC Hours Units			UTC Hours Tens				Universal Time Coordinated (UTC) 1. Byte	
20	UTC Minutes Units			UTC Minutes Tens				Universal Time Coordinated 2. Byte	
21	UTC Seconds Units			UTC Seconds Tens				Universal Time Coordinated 3. Byte	
22									Short Program Label 1. Byte
23									Short Program Label 2. Byte
24									Short Program Label 3. Byte
25									Short Program Label 4. Byte

This corresponds to the coding adopted in CCIR teletext system B BDSP 8/30 format 1.

NB: The received bytes are output on the I²C-Bus in a transparent way, i.e., on a bit-first-in-first-out basis. No bit manipulation is performed on the chip in this operating mode.

Concerning bytes no. 16 through 21: When evaluating the numbers, note that each 4-bit-digit has been incremented by one prior to transmission, and the least significant bits are transmitted first.

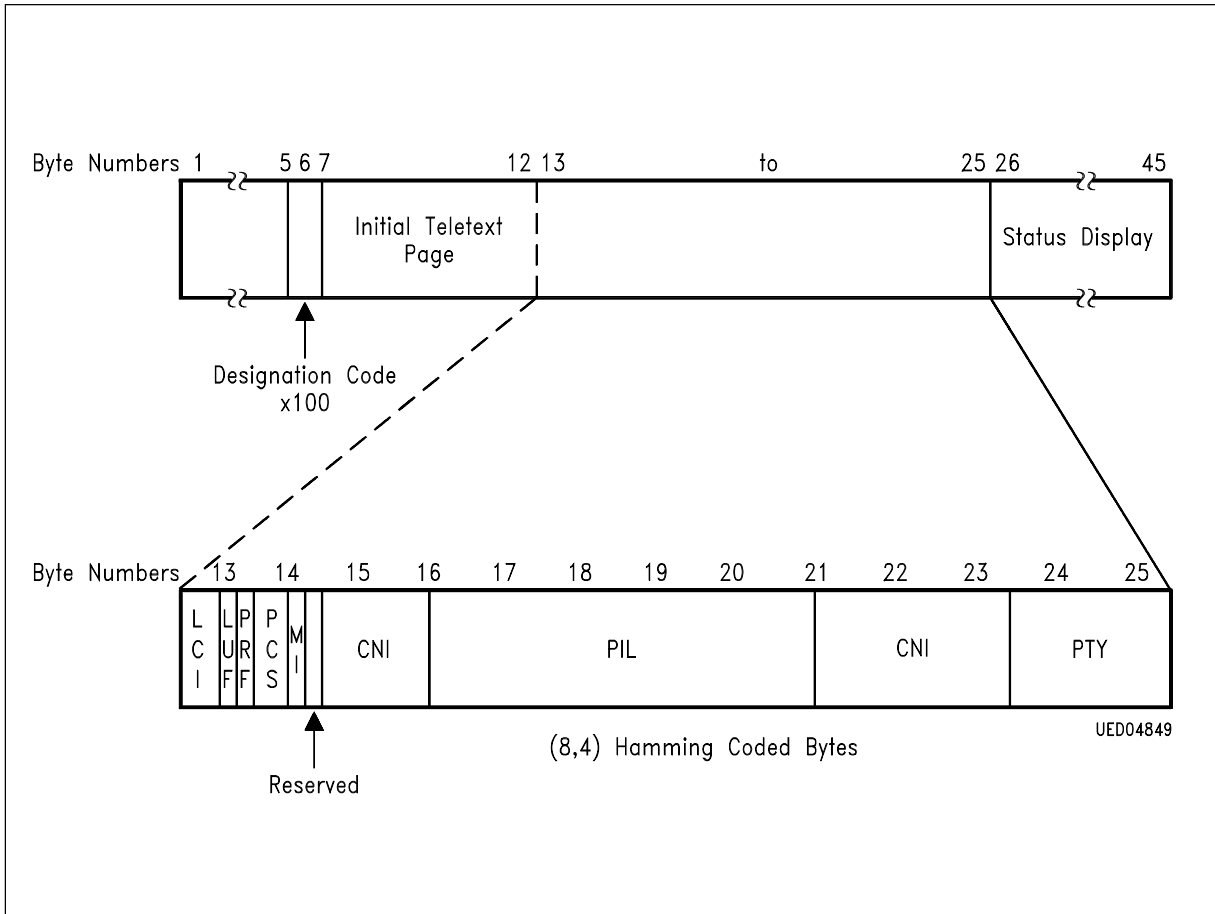

Structure of the Teletext Data Packet 8/30 Format 2

BDSP 8/30 Format 2 Bit Allocation

The four message bits of byte 13 are used as follows:

byte 13 bit 0 – LCI b_1) label channel identifier
 1 – LCI b_2)
 2 – LUF label update flag
 3 – reserved but as yet undefined

The message bits of bytes 14 – 25 are used in a way similar to the coding of the label in the dedicated television line as follows:

byte 14 bit 0 PCS b_1)	status of	byte 20 bit 0 PIL b_{15})	
1 PCS b_2)	analogue sound	1 PIL b_{16})	
2) reserved but yet	2 PIL b_{17})	minute
3) undefined	3 PIL b_{18})	
		byte 21 bit 0 PIL b_{19})	
		1 PIL b_{20})	
byte 15 bit 0 CNI b_1)		2 CNI b_5)	
1 CNI b_2)	country	3 CNI b_6)	country
2 CNI b_3)		byte 22 bit 0 CNI b_7)	
3 CNI b_4)		1 CNI b_8)	
byte 16 bit 0 CNI b_9)	network (or	2 CNI b_{11})	
1 CNI b_{10})	program provider)	3 CNI b_{12})	
2 PIL b_1)		byte 23 bit 0 CNI b_{13})	network (or
3 PIL b_2)		1 CNI b_{14})	program
byte 17 bit 0 PIL b_3)	day	2 CNI b_{15})	provider)
1 PIL b_4)		3 CNI b_{16})	
2 PIL b_5)		byte 24 bit 0 PTY b_1)	
3 PIL b_6)		1 PTY b_2)	
byte 18 bit 0 PIL b_7)	month	2 PTY b_3)	
1 PIL b_8)		3 PTY b_4)	program
2 PIL b_9)		byte 25 bit 0 PTY b_5)	type
3 PIL b_{10})		1 PTY b_6)	
byte 19 bit 0 PIL b_{11})		2 PTY b_7)	
1 PIL b_{12})	hour	3 PTY b_8)	
2 PIL b_{13})			
3 PIL b_{14})			

Data Format of the Program Delivery Data in the Dedicated TV Line

Time →

Parameter →	PCS				CNI				PIL				CNI				PTY					
	1	2	3 & 4	5	6 to 10	11	12	13	14	15	16	17	18	19	20	21	22	23	24			
Byte No. →																						
Parameter bits b _i , i = →				1, 2, 3, 4	1, 2, 3, 4																	
Transmission bit No. →				0 1 2 3 4 5 6 7	0 1 2 3 4 5 6 7																	
Content →	Clock run-in	Start code	Not relevant to PDC	Reserved for enhancement of VPS M L	Not relevant to PDC	Net. or prog. prov. bin.	Day binary	Month binary	Hour binary	Minute binary	Country binary	Network or program provider binary										
Reserved code values for receiver control (service codes)			Bits b ₁ and b ₂ : 00 don't know 01 mono 10 stereo 11 dual sound																			
			Not relevant to PDC																			
			Timer control code	N.....N																		
			Record inhibit/term.	N.....N																		
			Interruption code	N.....N																		
		Continuation code	N.....N																			
		Unenhanced VPS	1 1 1 1																			
		PTY not in use	N.....N																			

Abbreviations: CNI = Country and Network Identification
 PCS = Program Control Status
 PIL = Program Identification Label
 PTY = Program Type

M = Most-significant bit
 L = Least-significant bit

A = Bit value is that of the current PTY code
 N = Bit value is that of the current CNI code
 P = Bit value is that of the current PIL code