

**Programmable Schmitt Trigger with Memory, Dual Input Precision Level Detector**

The CA3098 Programmable Schmitt Trigger is a monolithic silicon integrated circuit designed to control high operating current loads such as thyristors, lamps, relays, etc. The CA3098 can be operated with either a single power supply with maximum operating voltage of 16V, or a dual power supply with maximum operating voltage of  $\pm 8V$ . It can directly control currents up to 150mA and operates with microwatt standby power dissipation when the current to be controlled is less than 30mA. The CA3098 contains the following major circuit function features (see Block Diagram):

1. Differential amplifiers and summer: the circuit uses two differential amplifiers, one to compare the input voltage with the "high" reference, and the other to compare the input with the "low" reference. The resultant output of the differential amplifiers actuates a summer circuit which delivers a trigger that initiates a change in state of a flip-flop.
2. Flip-flop: the flip-flop functions as a bistable "memory" element that changes state in response to each trigger command.
3. Driver and output stages: these stages permit the circuit to "sink" maximum peak load currents up to 150mA at terminal 3.
4. Programmable operating current: the circuit incorporates access at terminal 2 to permit programming the desired quiescent operating current and performance parameters.

**Pinout**

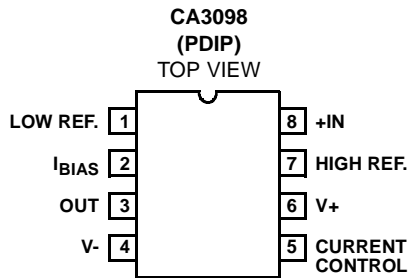

**Features**

- Programmable Operating Current
- Micropower Standby Dissipation
- Direct Control of Currents Up to . . . . . 150mA
- Low Input On/Off Current of Less Than 1nA for Programmable Bias Current of 1 $\mu$ A
- Built-in Hysteresis . . . . . 20mV (Max)

**Applications**

- Control of Relays, Heaters, LEDs, Lamps, Photosensitive Devices, Thyristors, Solenoids, etc.
- Signal Reconditioning
- Phase and Frequency Modulators
- On/Off Motor Switching
- Schmitt Triggers, Level Detectors
- Time Delays
- Overvoltage, Overcurrent, Overtemperature Protection
- Battery-Operated Equipment
- Square and Triangular-Wave Generators

**Part Number Information**

PART NUMBER	TEMP RANGE (°C)	PACKAGE	PKG. NO.
CA3098E	-55 to 125	8 Ld PDIP	E8.3

Block Diagram

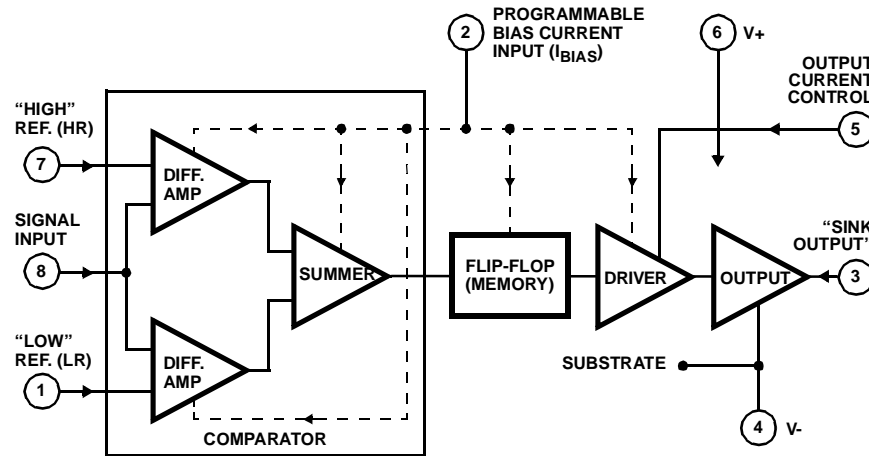

Schematic Diagram

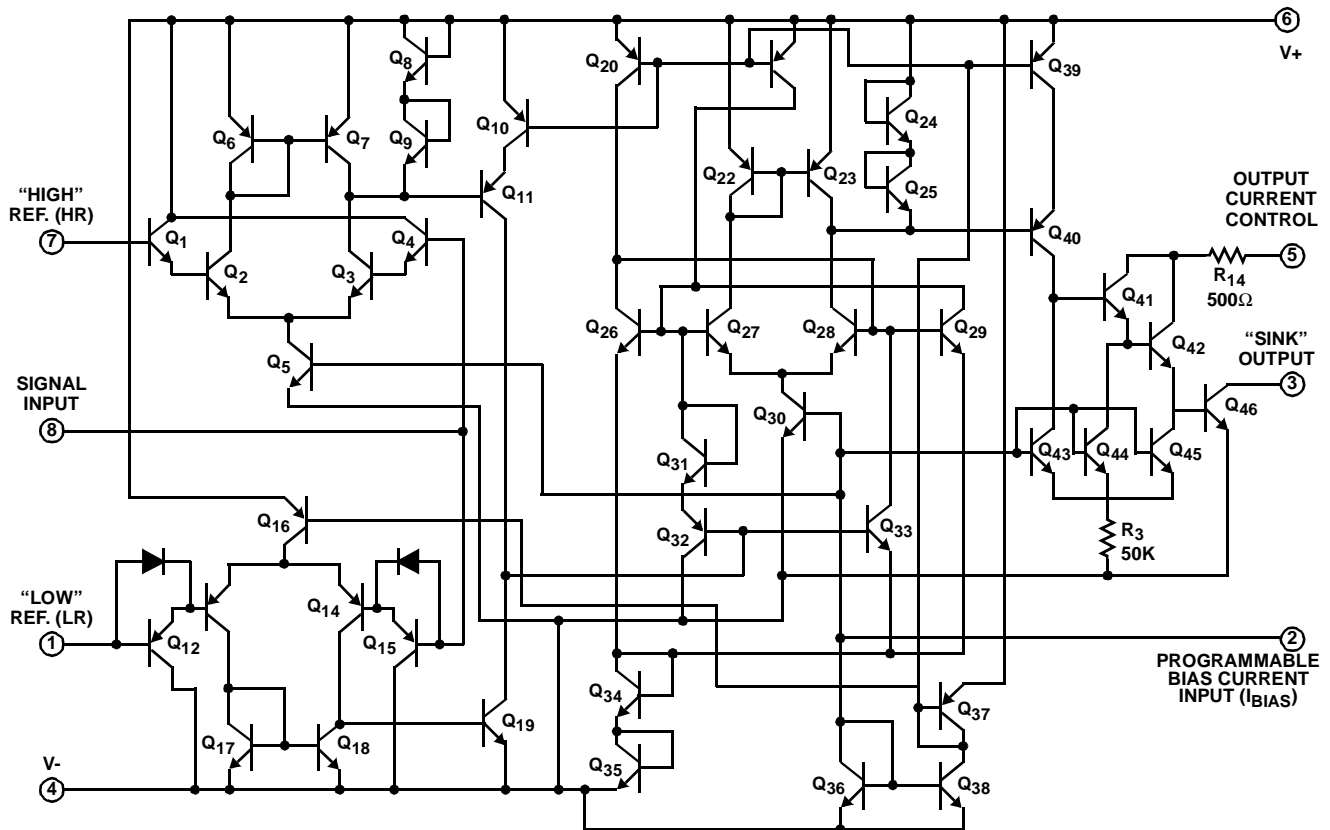

## Absolute Maximum Ratings

Supply Voltage Between V+ and V- . . . . .	16V
Voltage Between High Reference or Sink Output and V- . . . . .	16V
Differential Input Voltage Between Terminals 8 and 1 . . . . .	10V and Terminals 7 and 8
Load Current (Terminal 3) (Duty Cycle $\leq 25\%$ ) . . . . .	150mA
Input Current to Voltage Regulator (Terminal 5) . . . . .	25mA
Programmable Bias Current (Terminal 2) . . . . .	1mA
Output Current Control (Terminal 5). . . . .	15mA

## Operating Conditions

Temperature Range . . . . .	-55°C to 125°C
Voltage Range	
+IN . . . . .	V- to V+
HIGH REF . . . . .	(V- +2.0V) to V+
LOW REF . . . . .	(V-) to (V+ -2.0V)

CAUTION: Stresses above those listed in "Absolute Maximum Ratings" may cause permanent damage to the device. This is a stress only rating and operation of the device at these or any other conditions above those indicated in the operational sections of this specification is not implied.

## Thermal Information

Thermal Resistance (Typical, Note 3)	$\theta_{JA}$
PDIP Package . . . . .	125°C/W
Maximum Junction Temperature (Die) . . . . .	175°C
Maximum Junction Temperature (Plastic Package) . . . . .	150°C
Maximum Storage Temperature Range . . . . .	-65°C to 150°C
Maximum Lead Temperature (Soldering 10s) . . . . .	300°C

Electrical Specifications  $T_A = 25^\circ\text{C}$ , Unless Otherwise Specified

PARAMETER	SYMBOL	TEST CONDITIONS	CA3098			UNITS
			MIN	TYP	MAX	
Input Offset Voltage						
"Low" Reference (Figures 2, 5)	$V_{IO(LR)}$	$V_{LR} = \text{GND}$ , $V_{HR} = V+$ to $(V- +2V)$ , $I_{BIAS} = 100\mu\text{A}$	-15	-3	6	mV
"High Reference (Figures 2, 6)	$V_{IO(HR)}$	$V_{HR} = \text{GND}$ , $V_{LR} = V-$ to $(V+ -2V)$ , $I_{BIAS} = 100\mu\text{A}$	-10	-1	10	mV
Temperature Coefficient						
"Low" Reference (Figure 7)		-55°C to 125°C	-	4.5	-	$\mu\text{V}/^\circ\text{C}$
"High" Reference (Figure 8)		-55°C to 125°C	-	$\pm 8.2$	-	$\mu\text{V}/^\circ\text{C}$
Minimum Hysteresis						
Voltage (Figure 9)	$V_{IO(HR-LR)}$	$V_{REG} = 0\text{V}$ (Note 1), $V+ = 4\text{V}$ , $V- = -4\text{V}$ , $I_{BIAS} = 1\mu\text{A}$	-	3	20	mV
Temperature Coefficient (Figure 10)		-55°C to 125°C	-	6.7	-	$\mu\text{V}/^\circ\text{C}$
Output Saturation Voltage (Figures 11, 12)	$V_{CE(SAT)}$	$V_I = 5\text{V}$ , $V_{REG} = 6\text{V}$ (Note 1), $V+ = 12\text{V}$ , $I_{BIAS} = 100\mu\text{A}$	-	0.72	1.2	V
Total Supply Current	$I_{TOTAL}$					
"ON" (Figures 3, 13, 14)		$V_I = 6\text{V}$ , $V_{REG} > 6\text{V}$ (Note 1), $V+ = 16\text{V}$ , $I_{BIAS} = 100\mu\text{A}$	500	710	800	$\mu\text{A}$
"OFF" (Figures 3, 13, 14)		$V_I = 10\text{V}$ , $V_{REG} < 10\text{V}$ (Note 1), $V+ = 16\text{V}$ , $I_{BIAS} = 100\mu\text{A}$	400	560	750	$\mu\text{A}$
Input Bias Current (Figures 3, 15)	$I_{IB}$					
$I_{B(PNP)}$		$V_I = 16\text{V}$ , $V_{REG} < 16\text{V}$ (Note 1), $V+ = 16\text{V}$ , $I_{BIAS} = 100\mu\text{A}$	-	42	100	nA
$I_{B(NPN)}$		$V_I = 6\text{V}$ , $V_{REG} > 6\text{V}$ (Note 1), $V+ = 16\text{V}$ , $I_{BIAS} = 100\mu\text{A}$	-	28	100	nA
Output Leakage Current	$I_{CE(OFF)}$	Current from Terminal 3 when $Q_{46}$ is "OFF"	-	-	10	$\mu\text{A}$
Switching Times (Figures 4, 16-27)		$I_{BIAS} = 100\mu\text{A}$ , $V+ = 5\text{V}$ , $V_{REG} = 2.5\text{V}$ (Note 1)				
Delay Time	$t_D$		-	900	-	ns
Fall Time	$t_F$		-	30	-	ns
Rise Time	$t_R$		-	2000	-	ns
Storage Time	$t_S$		-	6.5	-	$\mu\text{s}$
Output Current (Note 2)	$I_O$		100	-	-	mA

### NOTES:

- For definition of  $V_{REG}$  see Figure 3.
- Continuous (DC) output current must be limited to  $\leq 40\text{mA}$ . For 100mA output current, the duty cycle must be  $\leq 40\%$ .
- $\theta_{JA}$  is measured with the component mounted on an evaluation PC board in free air.

**General Description of Circuit Operation**

When the signal input voltage of the CA3098 is equal to or less than the "low" reference voltage (LR), current flows from an external power supply through a load connected to Terminal 3 ("sink" output). This condition is maintained until the signal input voltage rises to or exceeds the "high" reference voltage (HR), thereby effecting a change in the state of the flip-flop (memory) such that the output stage interrupts current flow in the external load. This condition, in turn, is maintained until such time as the signal again becomes equal to or less than the "low" reference voltage.

The CA3098 comparator is unique in that it contains circuit provisions to permit programmability. This feature provides flexibility to the designer to optimize quiescent power consumption, input circuit characteristics, hysteresis, and additionally permits independent control of the comparator, namely, pulsing, strobing, keying, squelching, etc. Programmability is accomplished by means of the bias current ( $I_{BIAS}$ ) supplied to Terminal 2.

An auxiliary means of controlling the magnitude of load current flow at Terminal 3 is provided by "sinking" current into Terminal 5. Figure 1 highlights the operation of the CA3098 when connected as a simple hysteresis switch (Schmitt trigger).

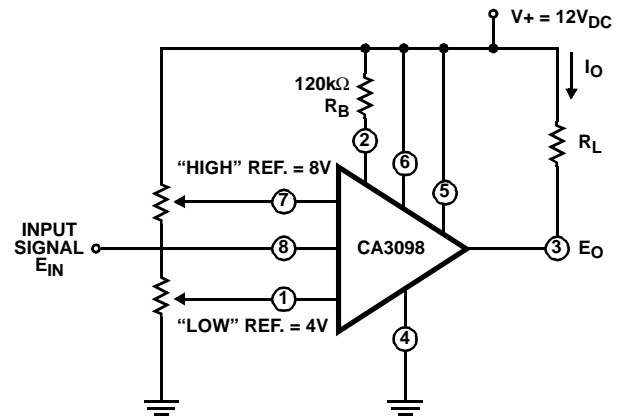

SEQUENCE	INPUT SIGNAL LEVEL	OUTPUT VOLTAGE (V) (TERMINAL 3)
1	$4 \geq E_{IN} > 0$	0
2	$8 \geq E_{IN} > 4$	0
3	$E_{IN} > 8$	12
2	$8 \geq E_{IN} > 4$	12
1	$4 \geq E_{IN} > 0$	0

**FIGURE 1. BASIC HYSTERESIS SWITCH (SCHMITT TRIGGER) AND RESULTANT OUTPUT STATES**

**Metallization Mask Layout**

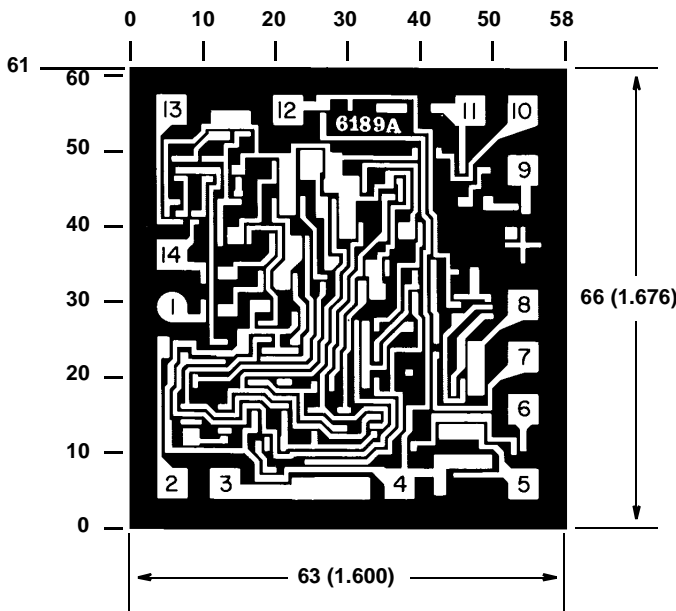

Dimensions in parentheses are in millimeters and are derived from the basic inch dimensions as indicated. Grid graduations are in mils ( $10^{-3}$  inch).

The layout represents a chip when it is part of the wafer. When the wafer is cut into chips, the cleavage angles are  $57^\circ$  instead of  $90^\circ$  with respect to the face of the chip. Therefore, the isolated chip is actually 7mils (0.17mm) larger in both dimensions.

Test Circuits

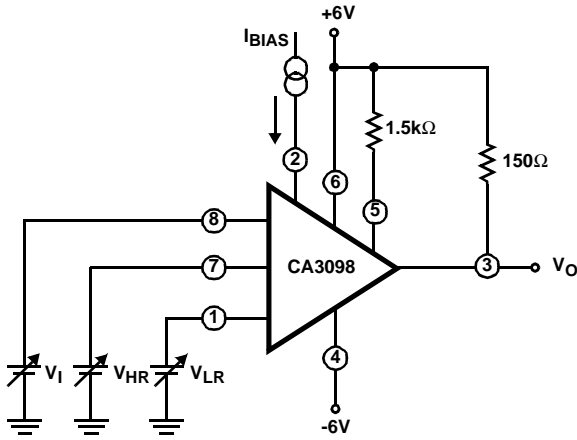

FIGURE 2. INPUT OFFSET VOLTAGE TEST CIRCUIT

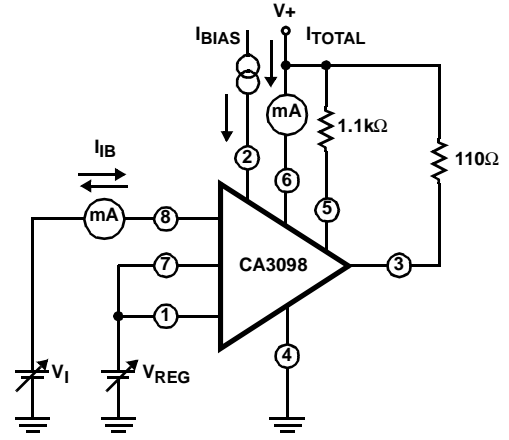

FIGURE 3. TOTAL SUPPLY CURRENT, AND INPUT BIAS CURRENT TEST CIRCUIT

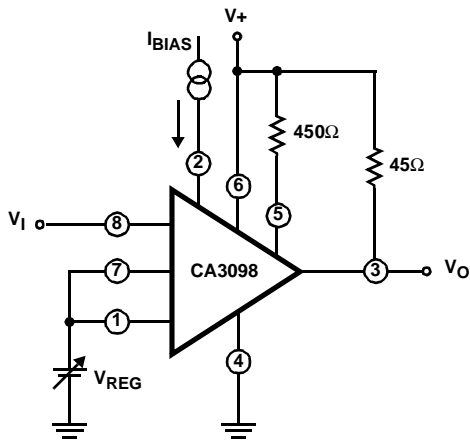
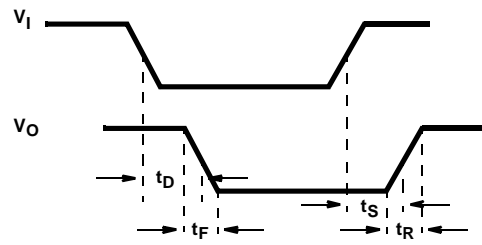

FIGURE 4. SWITCHING TIME TEST CIRCUIT



Typical Performance Curves

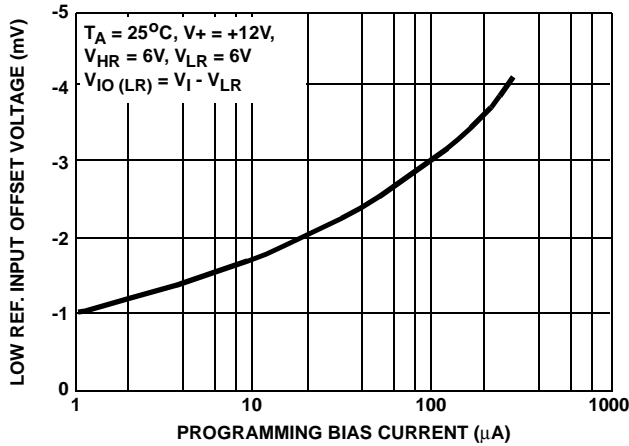

FIGURE 5. INPUT OFFSET VOLTAGE (“LOW” REFERENCE) vs PROGRAMMING BIAS CURRENT

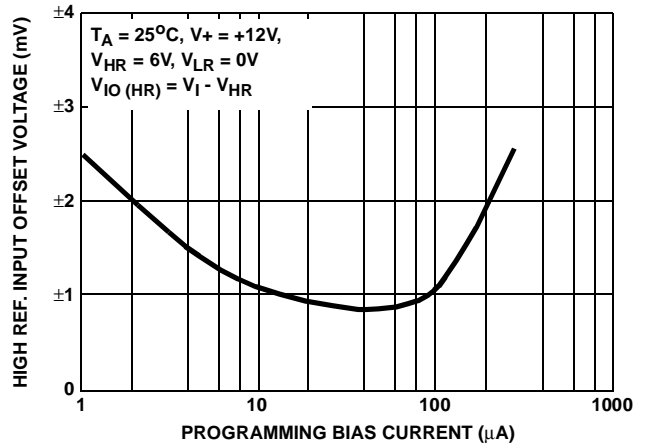

FIGURE 6. INPUT OFFSET VOLTAGE (“HIGH” REFERENCE) vs PROGRAMMING BIAS CURRENT

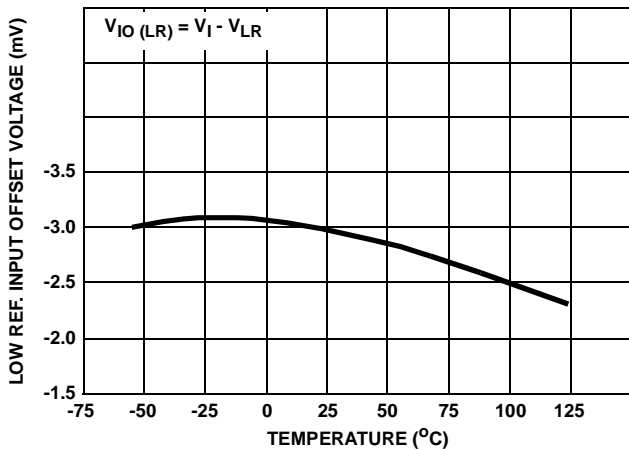

FIGURE 7. INPUT OFFSET VOLTAGE (“LOW” REFERENCE) vs AMBIENT TEMPERATURE

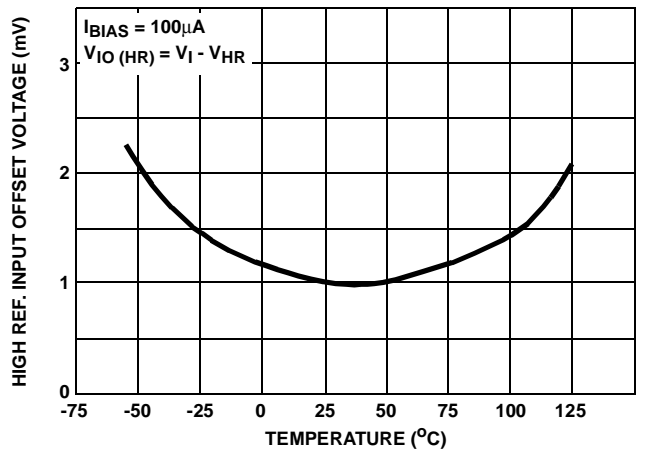

FIGURE 8. INPUT OFFSET VOLTAGE (“HIGH” REFERENCE) vs AMBIENT TEMPERATURE

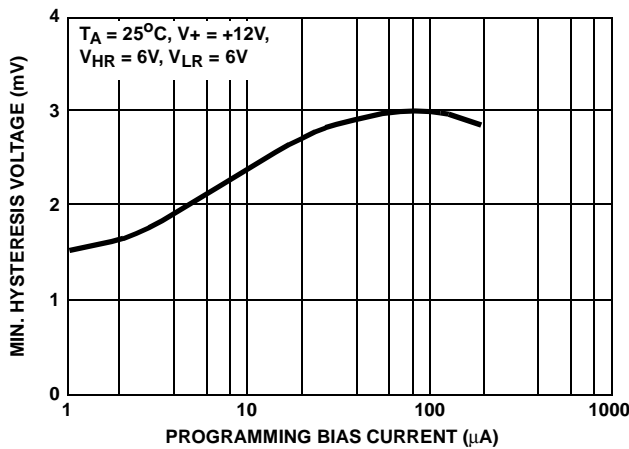

FIGURE 9. MINIMUM HYSTERESIS VOLTAGE vs PROGRAMMING BIAS CURRENT

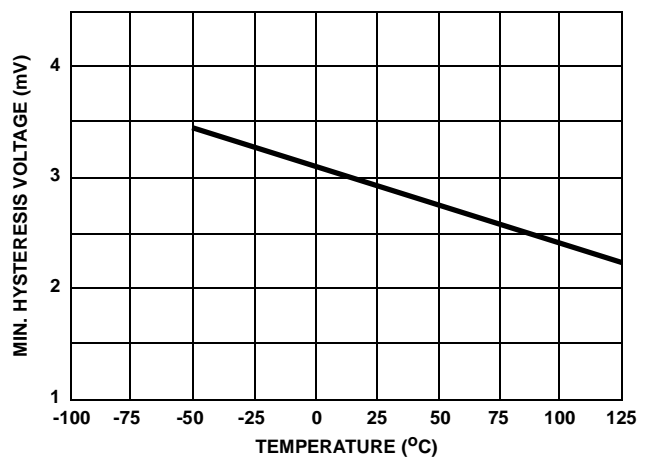

FIGURE 10. MINIMUM HYSTERESIS VOLTAGE vs AMBIENT TEMPERATURE

Typical Performance Curves (Continued)

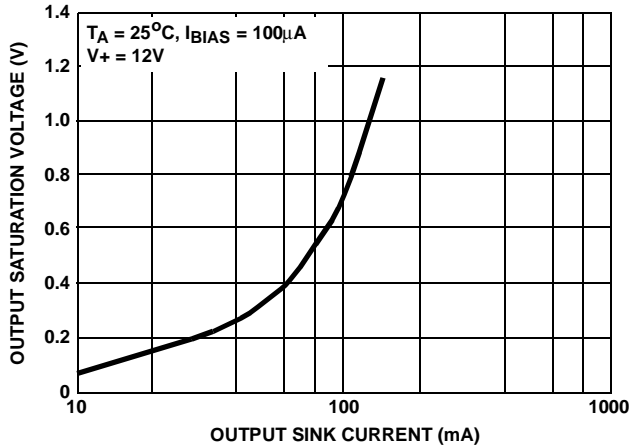

FIGURE 11. OUTPUT SATURATION VOLTAGE vs OUTPUT SINK CURRENT

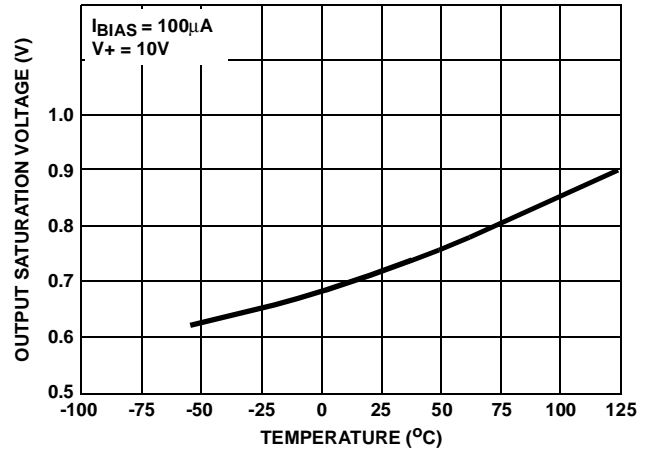
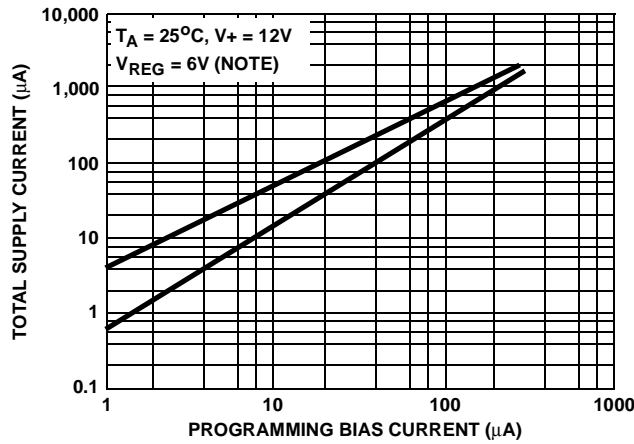

FIGURE 12. OUTPUT SATURATION VOLTAGE vs AMBIENT TEMPERATURE



NOTE: See Figure 3 for definition of  $V_{REG}$

FIGURE 13. TOTAL SUPPLY CURRENT vs PROGRAMMING BIAS CURRENT

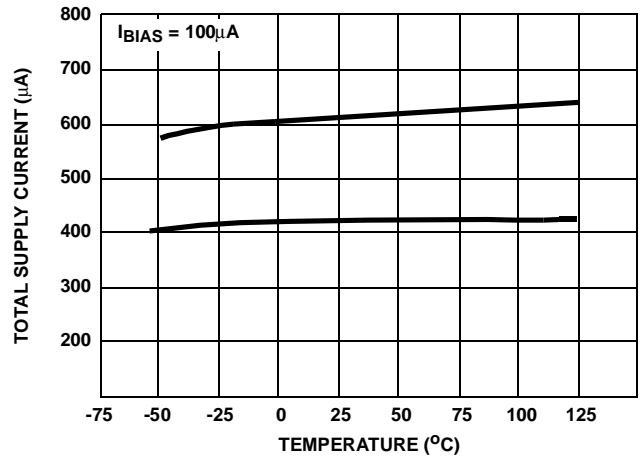
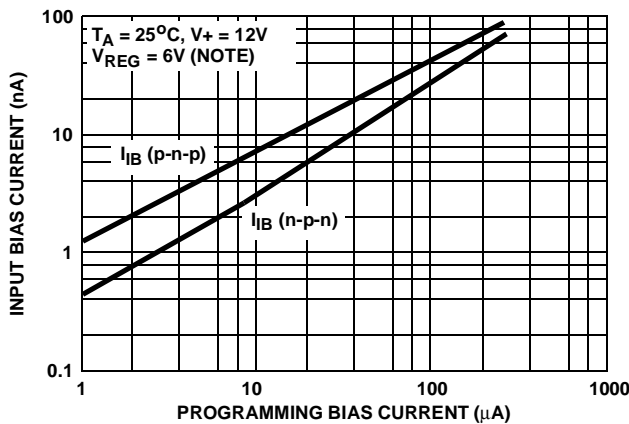

FIGURE 14. TOTAL SUPPLY CURRENT vs AMBIENT TEMPERATURE



NOTE: See Figure 3 for definition of  $V_{REG}$

FIGURE 15. INPUT BIAS CURRENT vs PROGRAMMING BIAS CURRENT

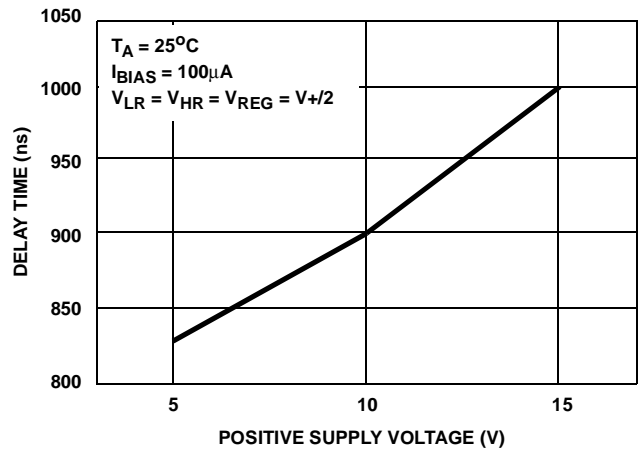

FIGURE 16. DELAY TIME vs SUPPLY VOLTAGE

Typical Performance Curves (Continued)

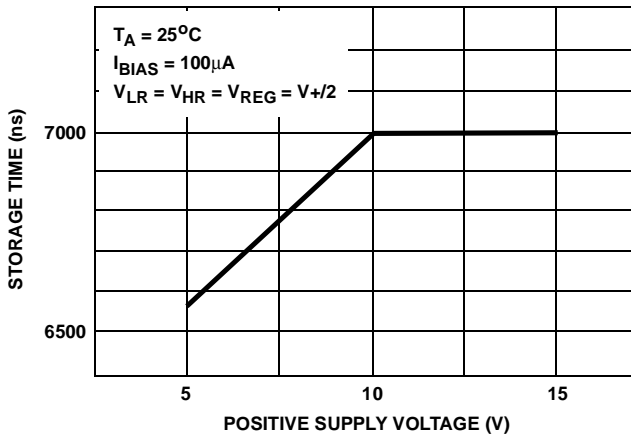

FIGURE 17. STORAGE TIME vs SUPPLY VOLTAGE

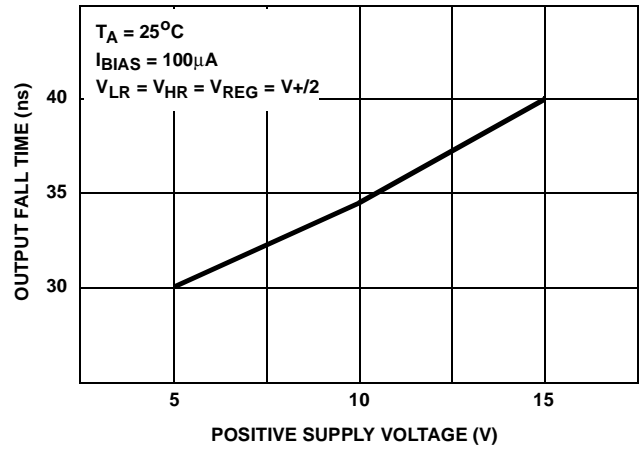

FIGURE 18. OUTPUT FALL TIME vs SUPPLY VOLTAGE

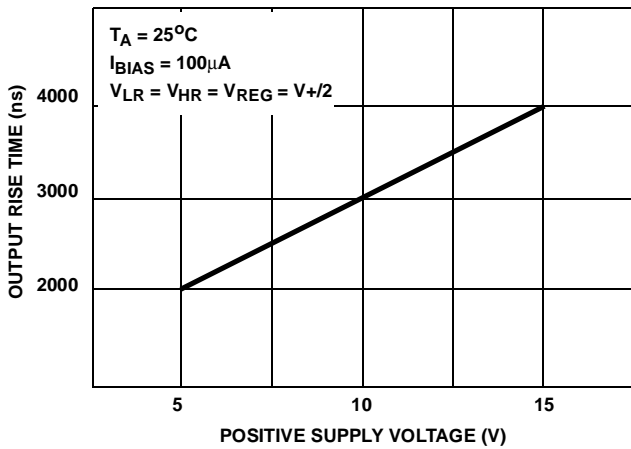

FIGURE 19. OUTPUT RISE TIME vs SUPPLY VOLTAGE

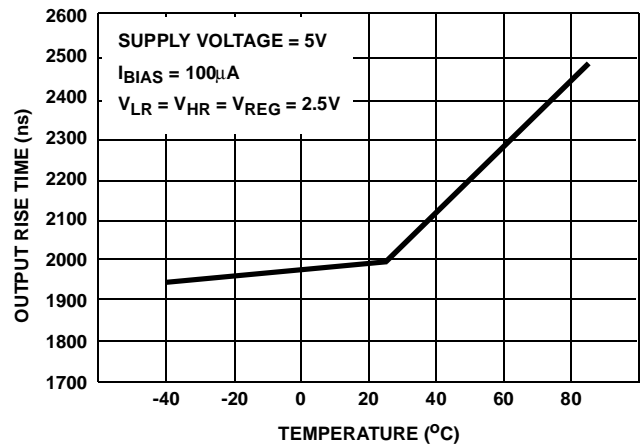

FIGURE 20. OUTPUT RISE TIME vs AMBIENT TEMPERATURE

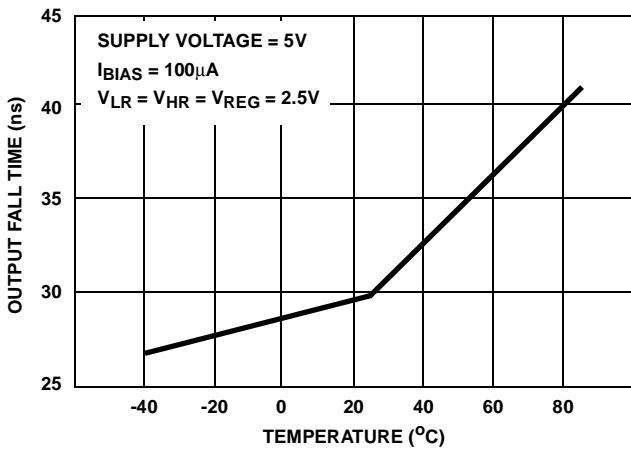

FIGURE 21. OUTPUT FALL TIME vs AMBIENT TEMPERATURE

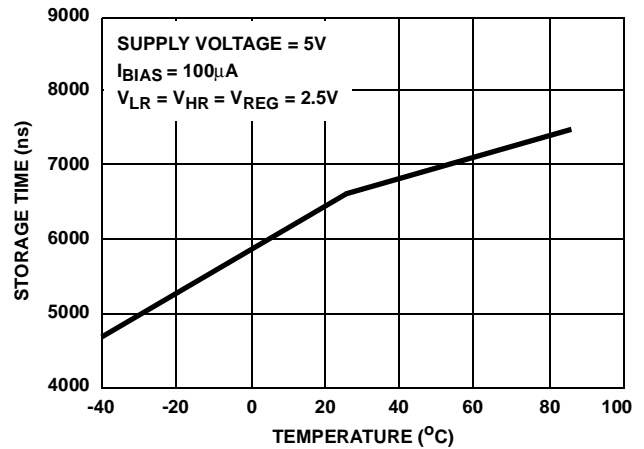

FIGURE 22. STORAGE TIME vs AMBIENT TEMPERATURE



Typical Performance Curves (Continued)

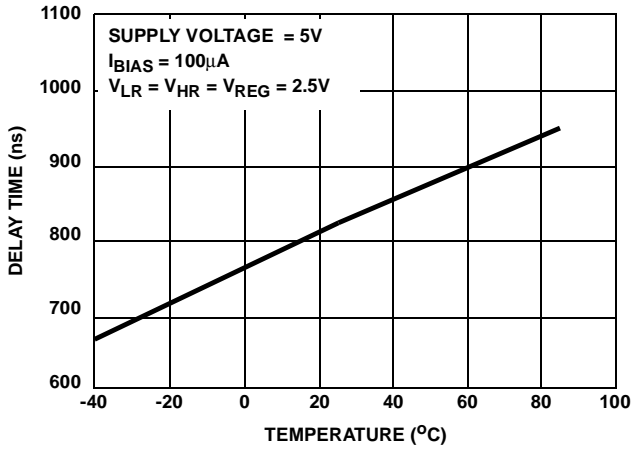

FIGURE 23. DELAY TIME vs AMBIENT TEMPERATURE

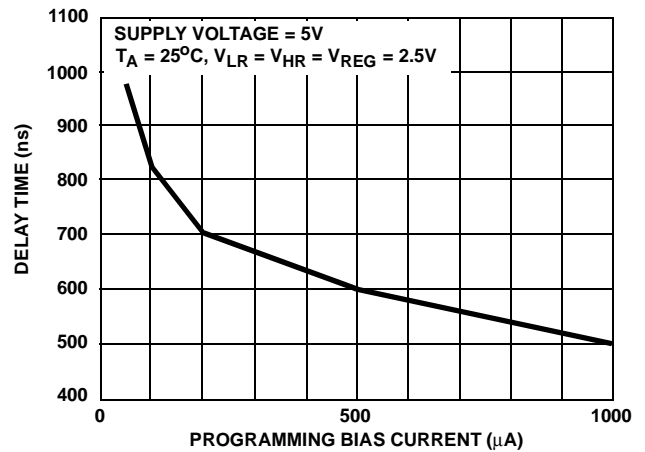

FIGURE 24. DELAY TIME vs PROGRAMMING BIAS CURRENT

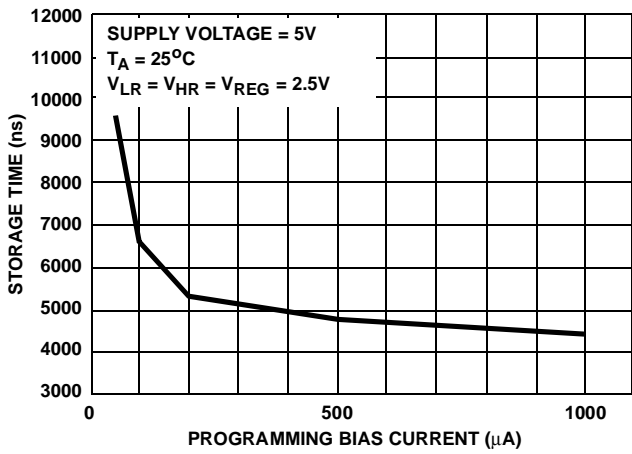

FIGURE 25. STORAGE TIME vs PROGRAMMING BIAS CURRENT

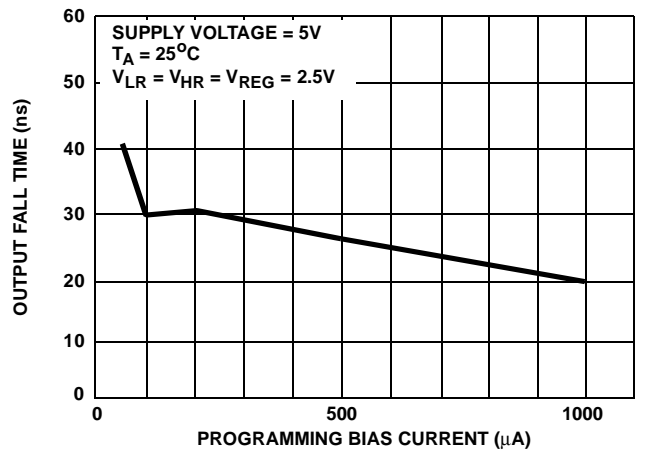

FIGURE 26. OUTPUT FALL TIME vs PROGRAMMING BIAS CURRENT

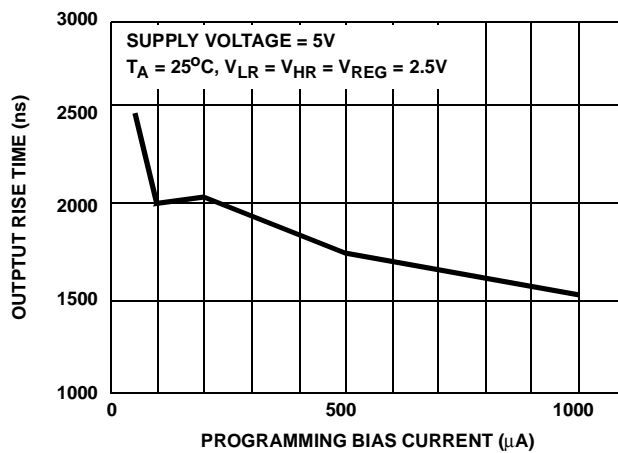

FIGURE 27. OUTPUT RISE TIME vs PROGRAMMING BIAS CURRENT

Typical Applications

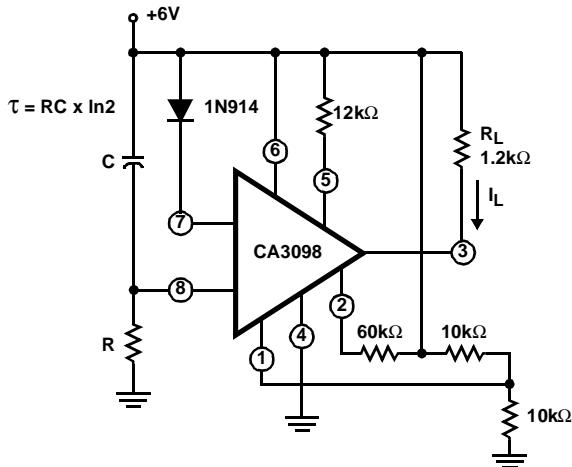

FIGURE 28. TIME DELAY CIRCUIT: TERMINAL 3 "SINKS" AFTER  $\tau$  SECONDS

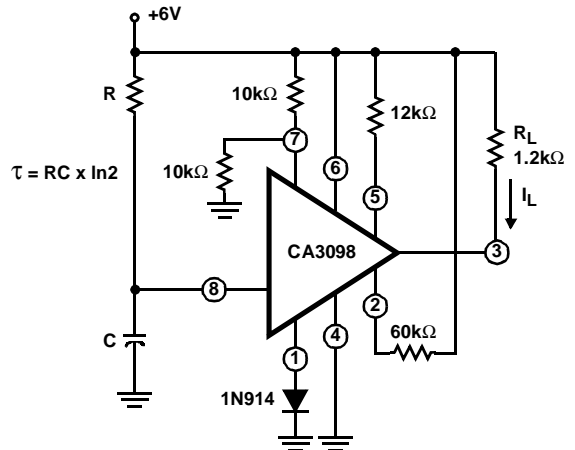

FIGURE 29. TIME DELAY CIRCUIT: "SINK" CURRENT INTERRUPTED AFTER  $\tau$  SECONDS

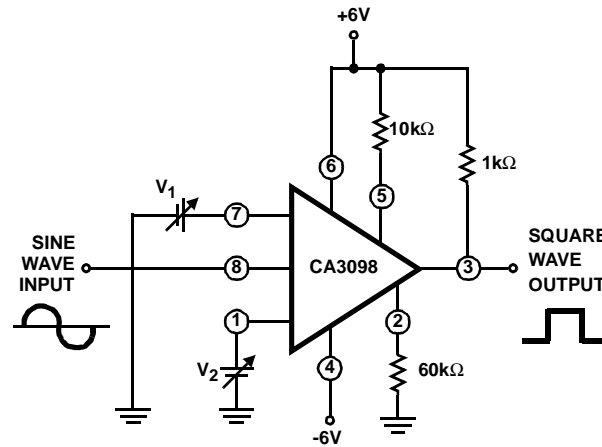

FIGURE 30. SINE WAVE TO SQUARE WAVE CONVERTER WITH DUTY CYCLE ADJUSTMENT ( $V_1$  AND  $V_2$ )

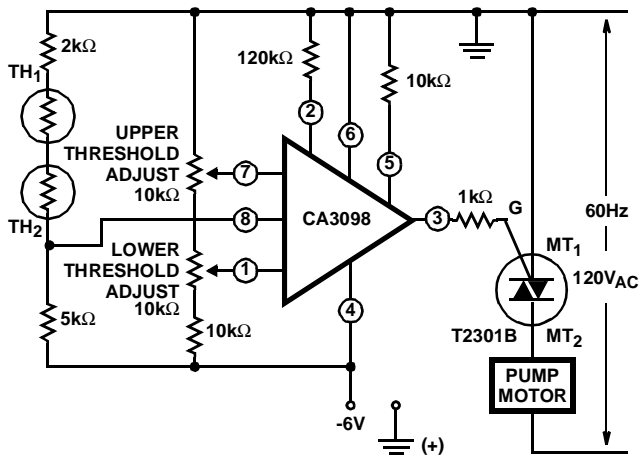
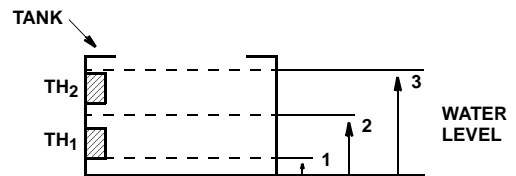

FIGURE 31A. WATER LEVEL CONTROL CIRCUIT



NOTES:

1. Motor pump is "ON" when water level rises above thermistor TH<sub>2</sub>.
2. Motor pump remains "ON" until water level falls below thermistor TH<sub>1</sub>.
3. Thermistors, operate in self heating mode.

FIGURE 31B. WATER LEVEL DIAGRAM FOR CIRCUIT  
FIGURE 31. WATER LEVEL CONTROL APPLICATION

Typical Applications (Continued)

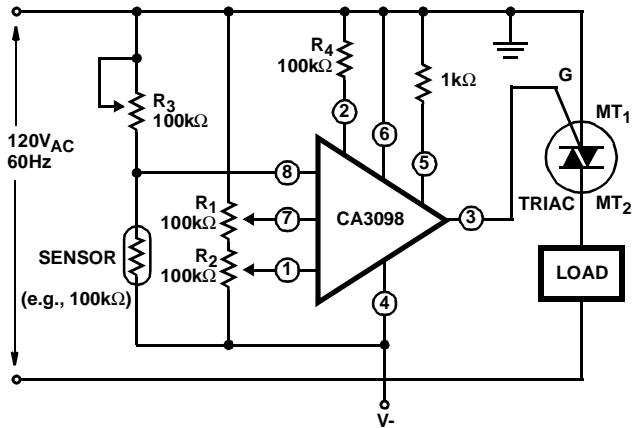
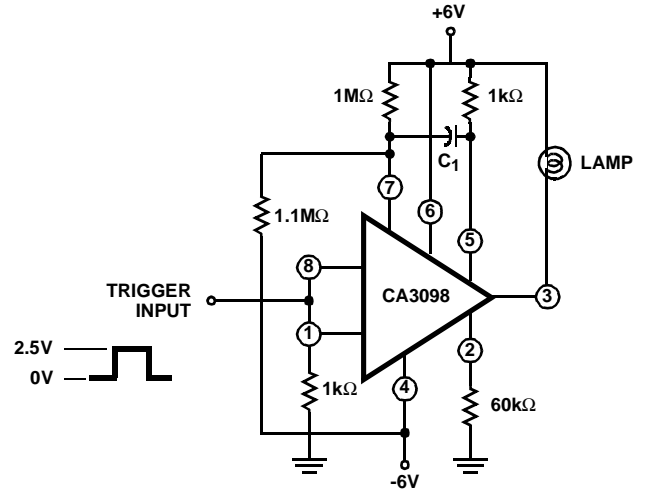

FIGURE 32. OFF/ON CONTROL OF TRIAC WITH PROGRAMMABLE HYSTERESIS



DESIRED $t_{ON}$ (ms)	VALUE OF $C_1$ ( $\mu F$ )
15	0.01
150	0.1
300	0.2

FIGURE 33. ONE SHOT MULTIVIBRATOR

Dual-In-Line Plastic Packages (PDIP)

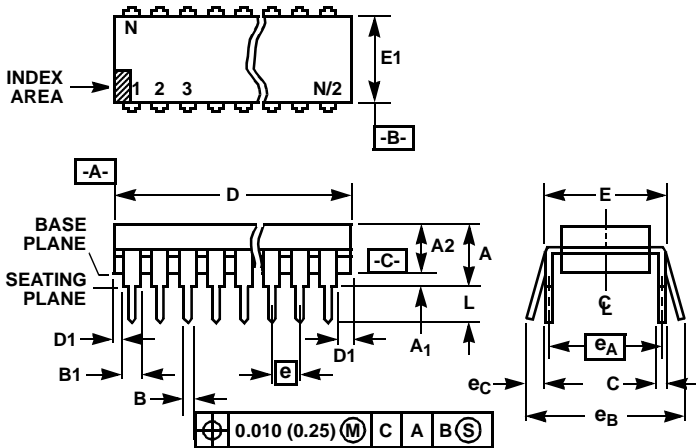

NOTES:

- Controlling Dimensions: INCH. In case of conflict between English and Metric dimensions, the inch dimensions control.
- Dimensioning and tolerancing per ANSI Y14.5M-1982.
- Symbols are defined in the "MO Series Symbol List" in Section 2.2 of Publication No. 95.
- Dimensions A, A1 and L are measured with the package seated in JEDEC seating plane gauge GS-3.
- D, D1, and E1 dimensions do not include mold flash or protrusions. Mold flash or protrusions shall not exceed 0.010 inch (0.25mm).
- E and  $e_A$  are measured with the leads constrained to be perpendicular to datum  $-C-$ .
- $e_B$  and  $e_C$  are measured at the lead tips with the leads unconstrained.  $e_C$  must be zero or greater.
- B1 maximum dimensions do not include dambar protrusions. Dambar protrusions shall not exceed 0.010 inch (0.25mm).
- N is the maximum number of terminal positions.
- Corner leads (1, N, N/2 and N/2 + 1) for E8.3, E16.3, E18.3, E28.3, E42.6 will have a B1 dimension of 0.030 - 0.045 inch (0.76 - 1.14mm).

E8.3 (JEDEC MS-001-BA ISSUE D)  
8 LEAD DUAL-IN-LINE PLASTIC PACKAGE

SYMBOL	INCHES		MILLIMETERS		NOTES
	MIN	MAX	MIN	MAX	
A	-	0.210	-	5.33	4
A1	0.015	-	0.39	-	4
A2	0.115	0.195	2.93	4.95	-
B	0.014	0.022	0.356	0.558	-
B1	0.045	0.070	1.15	1.77	8, 10
C	0.008	0.014	0.204	0.355	-
D	0.355	0.400	9.01	10.16	5
D1	0.005	-	0.13	-	5
E	0.300	0.325	7.62	8.25	6
E1	0.240	0.280	6.10	7.11	5
e	0.100 BSC		2.54 BSC		-
$e_A$	0.300 BSC		7.62 BSC		6
$e_B$	-	0.430	-	10.92	7
L	0.115	0.150	2.93	3.81	4
N	8		8		9

Rev. 0 12/93

All Intersil U.S. products are manufactured, assembled and tested utilizing ISO9000 quality systems. Intersil Corporation's quality certifications can be viewed at [www.intersil.com/design/quality](http://www.intersil.com/design/quality)

*Intersil products are sold by description only. Intersil Corporation reserves the right to make changes in circuit design, software and/or specifications at any time without notice. Accordingly, the reader is cautioned to verify that data sheets are current before placing orders. Information furnished by Intersil is believed to be accurate and reliable. However, no responsibility is assumed by Intersil or its subsidiaries for its use; nor for any infringements of patents or other rights of third parties which may result from its use. No license is granted by implication or otherwise under any patent or patent rights of Intersil or its subsidiaries.*

For information regarding Intersil Corporation and its products, see [www.intersil.com](http://www.intersil.com)

Sales Office Headquarters

**NORTH AMERICA**  
Intersil Corporation  
7585 Irvine Center Drive  
Suite 100  
Irvine, CA 92618  
TEL: (949) 341-7000  
FAX: (949) 341-7123

Intersil Corporation  
2401 Palm Bay Rd.  
Palm Bay, FL 32905  
TEL: (321) 724-7000  
FAX: (321) 724-7946

**EUROPE**  
Intersil Europe Sarl  
Ave. William Grasse, 3  
1006 Lausanne  
Switzerland  
TEL: +41 21 6140560  
FAX: +41 21 6140579

**ASIA**  
Intersil Corporation  
Unit 1804 18/F Guangdong Water Building  
83 Austin Road  
TST, Kowloon Hong Kong  
TEL: +852 2723 6339  
FAX: +852 2730 1433