



MOS DIGITAL INTEGRATED CIRCUIT

μ PD2819C

PHASE LOCKED LOOP FREQUENCY SYNTHESIZER CMOS LSI

DESCRIPTION The μ PD2819C is a CMOS LSI for a Phase Locked Loop Frequency Synthesizer for Digital Tuning System. The μ PD2819C is packaged in a 18 pin plastic dual in-line package (DIP).

- FEATURES**
- Programmable divider : divided-by 20 to 7999 (BCD)
 - Reference divider : $f_{ref} = 10\text{kHz}, 9\text{kHz}, 5\text{kHz}, 4.5\text{kHz}, 2.5\text{kHz}, 1\text{kHz}$
 - Phase detector
 - Reference oscillation circuit : 5.76MHz
 - Filter amplifier : $V_{DD2} = 20\text{V}(\text{max.})$ open drain
 - Serial data input : Numbers of lead wires=3
 - Two programmable divider inputs can be selected with program
 - Data input terminal can withstand input voltage higher than supply voltage
: $V_{IH2} = 0.7V_{DD1}$ to 15V
 - Clock pulse output for a controller : 360kHz and 25Hz (open drain)
 - Un-locked signal is detected as instant stop "IS" terminal
: locked ... high level, un-locked ... pulsed wave
 - High speed and low power consumption due to CMOS
 - Single power supply
: $V_{DD1} = 5 \pm 0.5$ volts
 - Operating temperature $T_{opt} = -35$ to $+75$ degrees centigrade

PACKAGE DIMENSIONS (Unit : mm)

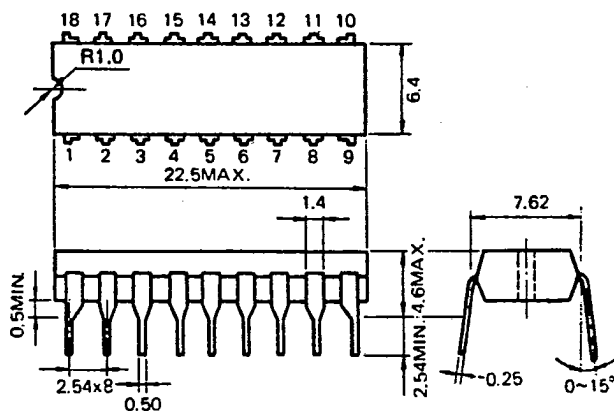

Nippon Electric Co., Ltd.

BLOCK DIAGRAM

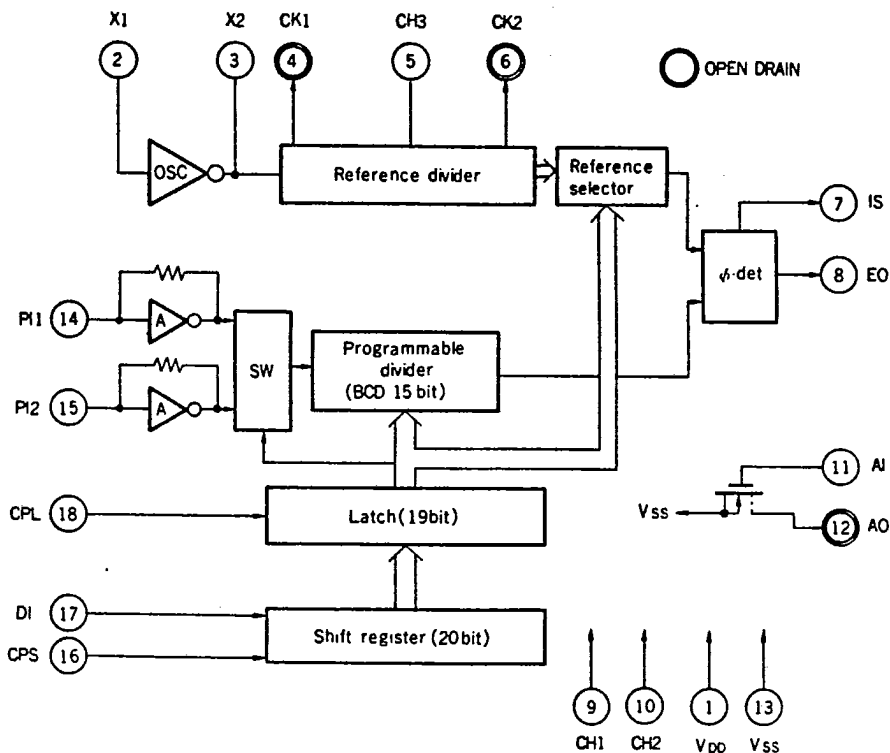

PIN CONNECTION

PIN#	SYMBOL	DESCRIPTION
1	V _{DD}	POWER SUPPLY (V _{DD} = 5 ±0.5V)
2	X1	X-tal OSCILLATOR (5.76MHz)
3	X2	
4	CK1	CLOCK OUTPUT (360kHz) OPEN DRAIN
5	CH3	CHECK TERMINAL (90kHz)
6	CK2	CLOCK OUTPUT (25Hz) OPEN DRAIN
7	IS	INSTANT STOP OUTPUT
8	EO	CHARGE PUMP OUTPUT (THREE STATE)
9	CH1	CHECK TERMINAL (REFERENCE FREQUENCY)
10	CH2	CHECK TERMINAL (PROGRAMMABLE DIVIDER OUTPUT)
11	A _I	ACTIVE FILTER INPUT
12	A _O	ACTIVE FILTER OUTPUT (OPEN DRAIN)
13	V _{SS}	GROUND
14	PI1	PROGRAMMABLE DIVIDER INPUT
15	PI2	PROGRAMMABLE DIVIDER INPUT
16	CPS	SHIFT REGISTER CLOCK INPUT
17	DI	SHIFT REGISTER DATA INPUT
18	CPL	LATCH CLOCK INPUT

INPUT PROGRAM DATA

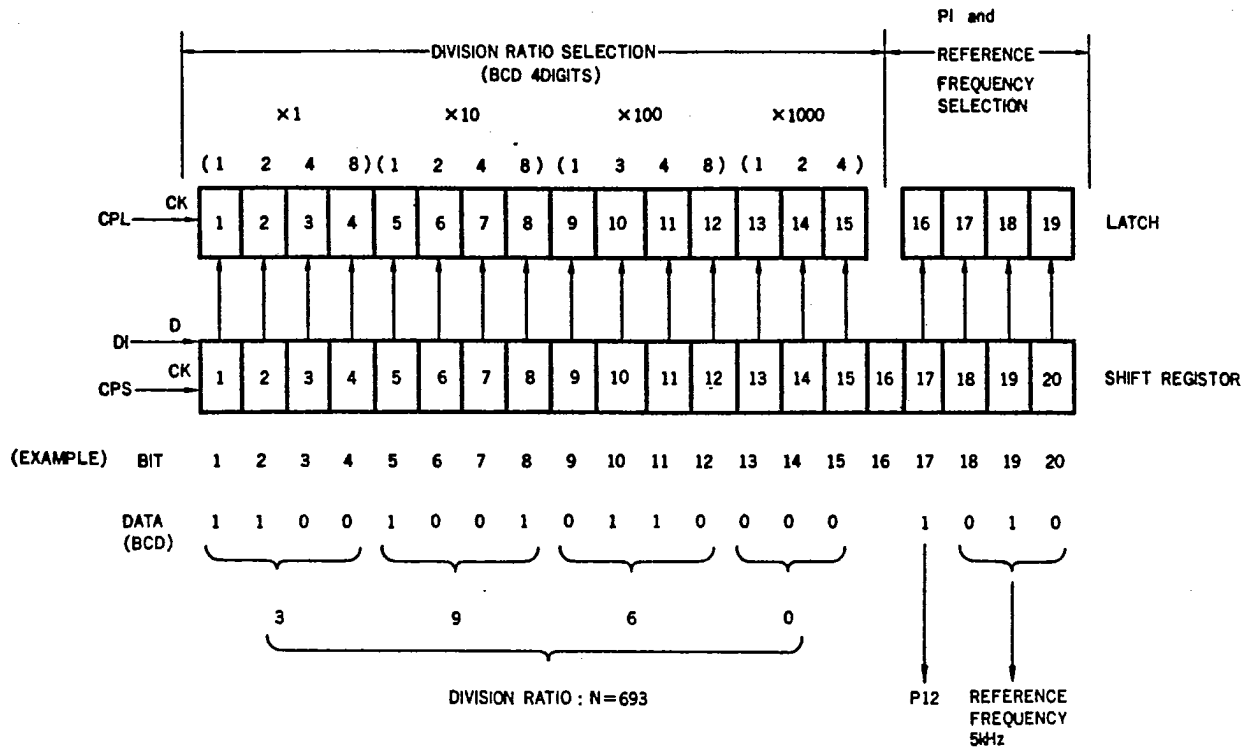

DATA WAVE FORM (EXAMPLE)

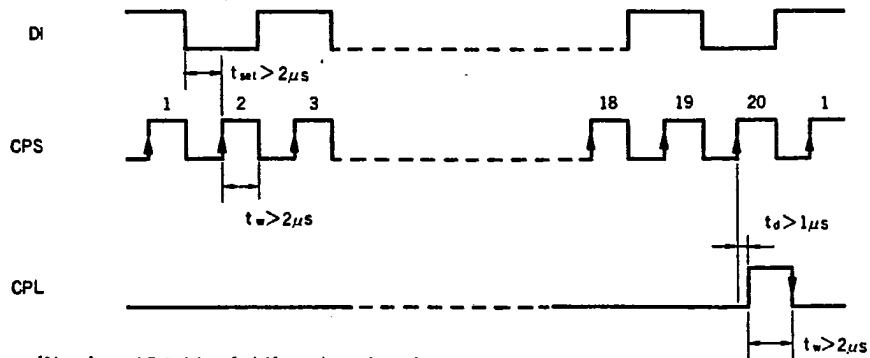

- 16th bit of shift register is a dummy.
- The data is shifted at positive edge of clock pulse (CPS).
- The data is latched at negative edge of latch pulse (CPL)

SELECTION OF PROGRAMMABLE DIVIDER INPUT AND REFERENCE FREQUENCY

17th bit	programmable divider input
0	P11
1	P12

reference frequency	18th bit	19th bit	20th bit
9	1	0	0
4.5	1	1	0
1	1	1	1
10	0	0	0
5	0	1	0
2.5	0	1	1

Nippon Electric Co., Ltd.

NEC Building, 33-1, Shiba-Gochome, Minato-ku, Tokyo 108, Japan
 Tel: Tokyo 454-1111
 Telex Address: NECTOK A J22686
 Cable Address: MICROPHONE TOKYO

IC-1193B
 APR. 18-79M
 Printed in Japan

ABSOLUTE MAXIMUM RATINGS (Ta = 25°C)

Supply Voltage 1	V _{DD1}	-0.3 to +6.0	V	(V _{DD})
Supply Voltage 2	V _{DD2}	-0.3 to +20	V	(CK1, CK2, AO)
Input Voltage 1	V _{I1}	-0.3 to V _{DD1}	V	
Input Voltage 2	V _{I2}	-0.3 to +18	V	(CPL, CPS, DI)
Operating Temperature	T _{opt}	-35 to +75	°C	
Storage Temperature	T _{stg}	-55 to +125	°C	

ELECTRICAL CHARACTERISTICS (Ta = -35 to +75°C)

CHARACTERISTIC	SYMBOL	MIN.	TYP.	MAX.	UNIT	TEST CONDITION
Supply Voltage 1	V _{DD1}	4.5	5.0	5.5	V	
High Level Input Voltage 1	V _{IH1}	0.7V _{DD}		V _{DD}	V	all inputs except CPS, CPL, DI
High Level Input Voltage 2	V _{IH2}	0.7V _{DD}		15	V	CPS, CPL, DI
Low Level Input Voltage	V _{IL}	-0.3		0.3V _{DD}	V	all inputs except AI, PI1, PI2
High Level Output Voltage	V _{OH}	0.7V _{DD}		V _{DD}	V	all outputs, I _{OH} = -1.0mA
Low Level Output Voltage	V _{OL}	0		0.3V _{DD}	V	all outputs, I _{OL} = 1.0mA
High Level Input Current 1	I _{IH1}			1.0	μA	all inputs except AI, PI1, PI2
Low Level Input Current 1	I _{IL1}			-1.0	μA	all inputs except AI, PI1, PI2
High Level Input Current 2	I _{IH2}		1.0		nA	AI
Low Level Input Current 2	I _{IL2}		-1.0		nA	AI
Leak Current	I _L		1.0		nA	EO(floating)
Maximum Frequency Response	f _{dmax}	5.76			MHz	X1-X2, DIVIDER, V _{DD} = 3.5V
	f _{pmax}	7.2			MHz	PI1, PI2
Total Current	I _{DD}			5	mA	f _{in} = 0, f _d = 5.76MHz
A.C. Input Voltage	V _i	1.0			V _{p-p}	PI1, PI2