

3-phase motor driver

BA6870S

The BA6870S is a 3-phase, full-wave, pseudo-linear motor driver suited for VCR capstan motors. The IC has a torque ripple cancellation circuit to reduce wow and flutter, and an output transistor saturation prevention circuit that provides superb motor control over a wide range of current. The built-in motor power series regulator allows applications with low power consumption.

●Applications

3-phase VCR capstan motors

●Features

- 1) 3-phase, full-wave, pseudo-linear driver system.
- 2) High performance torque ripple cancellation circuit.
- 3) Reversal braking by detecting the motor direction.
- 4) Saturation prevention circuit for high- and low-side output transistors.
- 5) Motor power supply series regulators.
- 6) Built-in circuit for output-to-GND short-circuit detection.

●Absolute maximum ratings (Ta = 25°C)

Parameter	Symbol	Limits	Unit
Applied voltage	V _{CC1}	7	V
Applied voltage	V _{CC2} , V _M	36	V
Power dissipation	P _d	3100*1	mW
Operating temperature	T _{opr}	-20~+75	°C
Storage temperature	T _{stg}	-40~+150	°C
Allowable output current	I _{OPEAK}	1.5*2	A

*1 Reduced by 24.8mW for each increase in Ta of 1°C over 25°C.

*2 Should not exceed Pd or ASO values.

●Recommended operating conditions (Ta = 25°C)

Parameter	Symbol	Min.	Typ.	Max.	Unit
Operating power supply voltage	V _{CC1}	4	5	6	V
	V _{CC2}	3	—	32	V
	V _M	3	12	32	V

●Block diagram

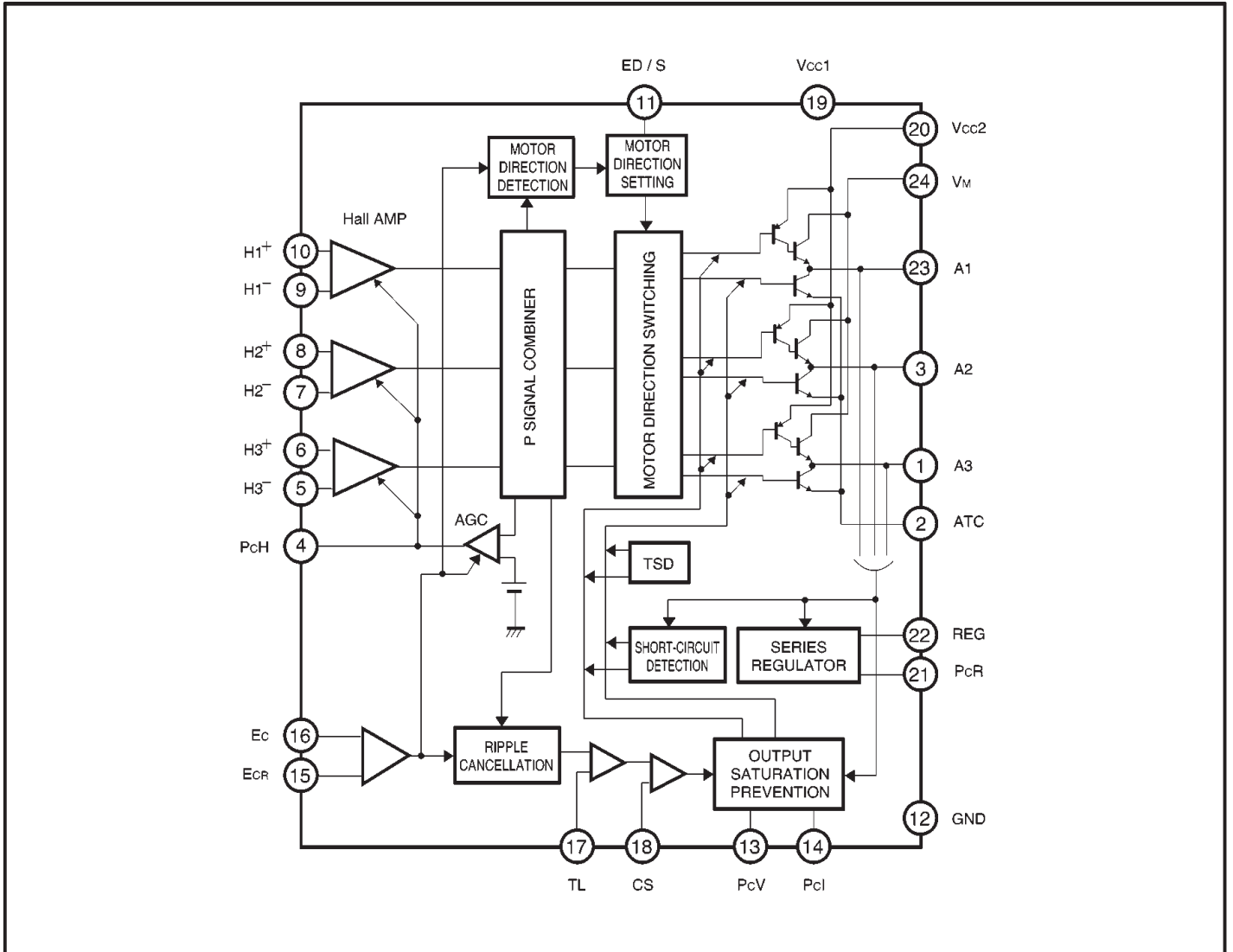

●Pin descriptions

Pin No.	Pin name	Function
1	A3	Motor output
2	ATC	Driver ground
3	A2	Motor output
4	PcH	Phase compensation pin for hall amplifier AGC
5	H3 ⁻	Hall signal input
6	H3 ⁺	Hall signal input
7	H2 ⁻	Hall signal input
8	H2 ⁺	Hall signal input
9	H1 ⁻	Hall signal input
10	H1 ⁺	Hall signal input
11	ED / S	Forward / stop / reverse switching input
12	GND	Signal ground

Pin No.	Pin name	Function
13	PcV	Phase compensation pin for preventing driver high-side saturation
14	PcI	Phase compensation pin for preventing driver low-side saturation
15	E _{CR}	Torque control reference input
16	E _C	Torque control input
17	TL	Torque limit
18	CS	Current sensing input
19	V _{CC1}	Signal power supply
20	V _{CC2}	Signal power supply
21	PcR	Phase compensation for series reg.
22	REG	Series regulator output (sink)
23	A1	Motor output
24	V _M	Motor power supply

●Electrical characteristics (unless otherwise noted, Ta = 25°C, V_{CC1} = 5V, V_M = V_{CC2} = 12V)

Parameter	Symbol	Min.	Typ.	Max.	Unit	Conditions
Torque control input/output gain	G _{io}	0.26	0.32	0.38	—	E _C = 2.2→2.1 V; Input = (L, L, H)
Ripple cancellation ratio	V _{RCC}	4.0	6.3	8.6	%	Input = (L, L, H)→(L, M, H)
Output high level voltage	V _{OH}	0.9	1.3	1.7	V	I _o =0.8A
Output low level voltage	V _{OL}	0.95	1.3	1.65	V	I _o =0.8A
Series regulator current capacity	I _{REG}	17	30	—	mA	V _{REG} =2V

●Circuit operation

(1) Pseudo-linear output and torque ripple cancellation
 The IC generates a trapezoidal (pseudo-linear) output current, whose waveform phase is 30 degrees ahead of that of the Hall input voltage (Fig. 1).

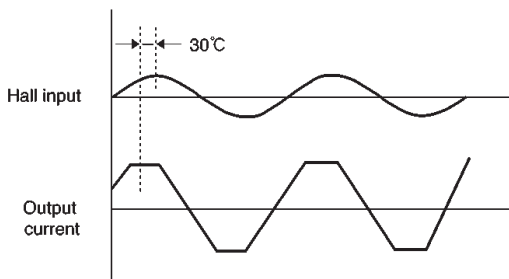

Fig.1

The trapezoidal waveform of output current would create intermittence in the magnetic field generated by the 3-phase motor, and would result in an irregular rotation of the motor. To prevent this, the output waveform is obtained by superimposing a triangular wave on the trapezoidal wave (Fig. 2). This process is called torque ripple cancellation.

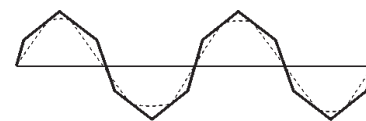

Fig.2

(2) Torque control and reversal brake

The output current can be controlled by adjusting the voltage applied to the torque control pins (pins 15 and 16).

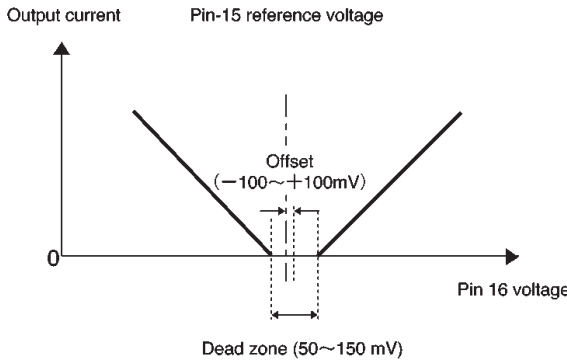

Fig.3

These pins are the inputs to a differential amplifier. A reference voltage between 2.3 ~ 3.0V (2.5V recommended) is applied to pin 15.

A brake is applied to the motor as described in the following. When the motor is running, pin 16 is given a negative potential with respect to the reference potential. If the pin-16 potential becomes positive, the IC detects the rise of pin-16 potential above the reference potential and activates the motor direction detecting circuit.

The motor direction detecting circuit sends a signal to the motor direction setting circuit to reverse the motor direction. This causes a braking torque that depends on the pin-16 potential, so that the motor quickly reduces its speed. At the same time, the positive pin-16 potential is shifted to the reference potential, so that the motor stops smoothly.

(3) Output current sensing and torque limitation

Pin 2 is the ground pin for the output stage. To sense the output current, a resistor (0.5Ω recommended) is connected between pin 2 and the ground. The output current is sensed by applying the voltage developed across this resistor to pin 18 as a feedback.

The output current can be limited by adjusting the voltage applied to pin 17. The current is limited when pin 17 reaches the same potential as pin 18. The output current ($I_{MAX.}$) under this condition is given by:

$$I_{MAX.} = \frac{V_{17P} - (TL - CS_{ofs})}{R_{2P}}$$

Where R_{2P} is the value of the resistor connected between pin 2 and the ground, V_{17P} is the voltage applied to pin 17, and $(TL - CS_{ofs})$ is the offset between the TL and CS pins.

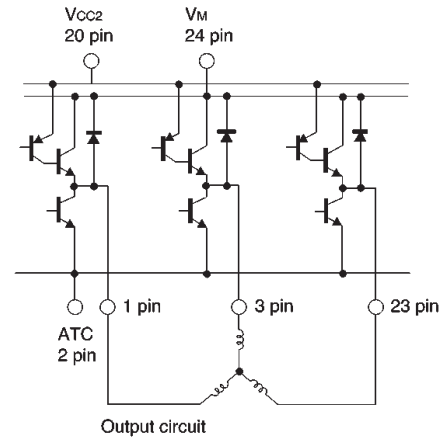

Fig.4 Output circuit

(4) Motor direction control (pin 11)

The motor mode is:

Forward when the pin 11 voltage is less than 0.9V,
 Stop when the voltage is between 1.3 ~ 3.0V,
 Reverse when the voltage is above 3.5V.

In the stop mode, high- and low-side output transistors are turned off, resulting in a high impedance state.

(5) Output transistor saturation prevention circuit

This circuit monitors the output voltage and maintain the operation of the output transistors below their saturation levels. Operating the transistors in the linear characteristic range provides good control over a wide range of current and good torque characteristics even during overloading.

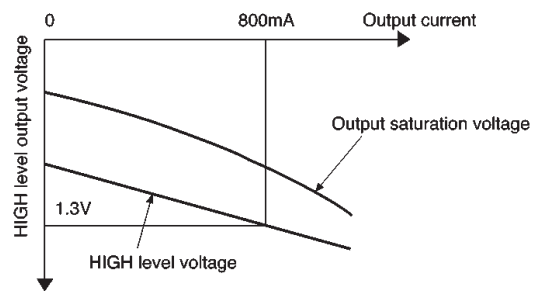

Fig.5 High level output voltage vs. output current (Reference value)

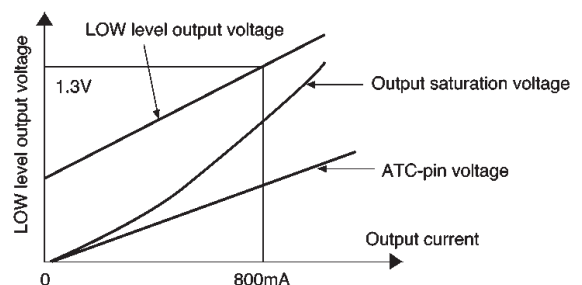

Fig.6 Low level output voltage vs. output current (Reference value)

(6) Series regulator

The BA6870S has a series regulator output pin. The IC outputs a sink current according to the HIGH level output voltage detected.

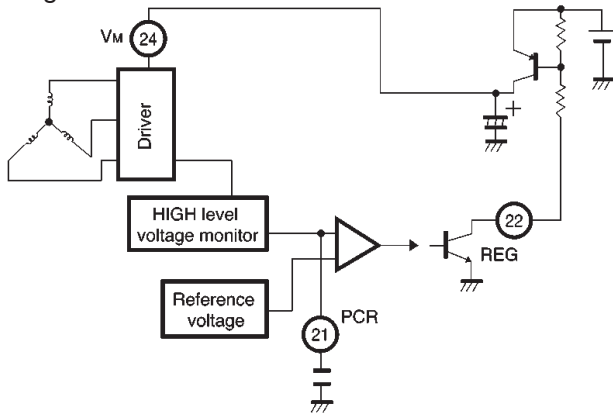

Fig.7

As shown in Fig. 7 the regulator circuit reduces the power consumed by the IC by reducing the collector-to-emitter (C-E) voltage of the driver transistors.

Nearly all the power dissipated by the IC is dissipated between the collectors and emitters of the output transistors. More power is consumed as the C-E voltage increases and as the output current increases.

The output transistor C-E voltage is equal to the difference between the supply voltage and the voltage applied to the motor. Because the voltage across the motor decreases with decreasing drive current, the C-E voltage must increase if the supply voltage is fixed.

Therefore, to improve the efficiency of the driver and to prevent the power rating of the IC being exceeded, the supply voltage must be varied in response to changes in the output current. The supply voltage is decreased at low current and increased at high current so that no excessive voltage is applied between the output transistor collectors and emitters.

(7) Output-to-ground short-circuit detection

The motor output pins of the IC may be short-circuited to the ground by some fault conditions. A short-circuited output can destroy the output transistors because of excessive current, excessive voltage, or both. Even when a short-circuit condition does not completely destroy the device, it can still cause extreme overheating. To prevent this, the BA6870S contains a short-circuit detection circuit that turns off the motor drive current if the output-to-ground potential becomes abnormally low.

●Operation notes

The BA6870S has two thermal shutdown circuits (TSD1 and TSD2) to protect the IC. The typical shutdown temperatures are 175°C for TSD1 and 215°C for TSD 2.

When the TSD1 is activated at an elevated chip temperature, the output pins (pins 1, 3, and 23) are set to the open state. TSD1 is functional against excessive power dissipation, output short-circuiting, and other irregularities in the output current, but does not work against overheating caused by high internal currents due to externally caused IC damage or pin-to-pin short-circuiting.

When TSD2 is activated at a higher chip temperature, the high- and low-side output transistors are turned on, and the internal resistance between the motor power supply pin (pin 24) and the output ground pin (pin 2) drops to less than 3Ω. The motor power supply current (I_M) is then given by

$$I_M = \frac{V_M (V)}{R_M + R_{2P} + 3 (\Omega)}$$

Where

I_M is the motor supply current

V_M is the motor supply voltage,

R_M is the motor power supply output resistance,

R_{2P} is the pin-2 resistance.

In your application, make sure to connect between the motor power supply and pin 24 a circuit breaker that operates at currents less than I_M.

●Application example

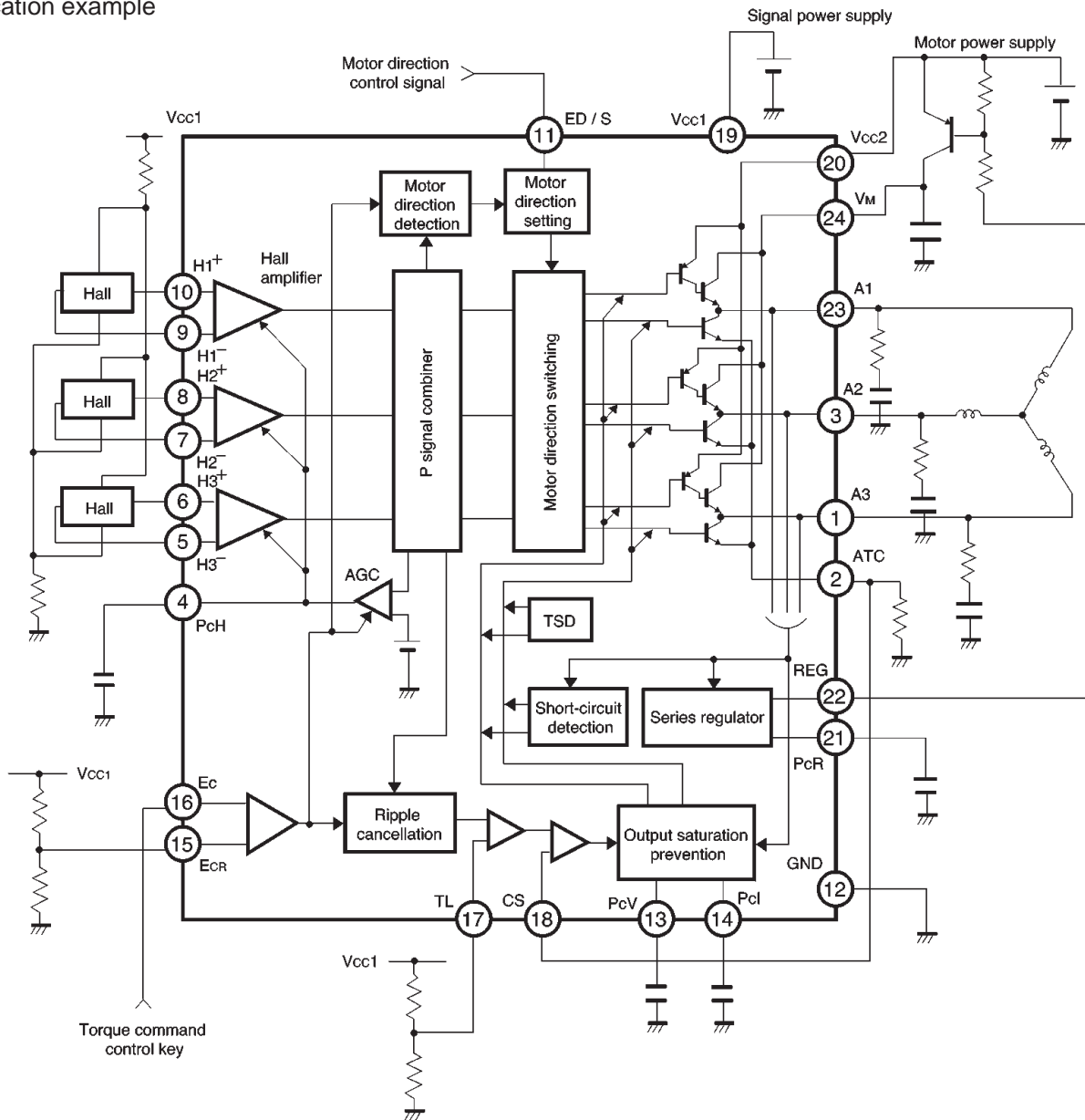

Fig.8

●Electrical characteristic curves

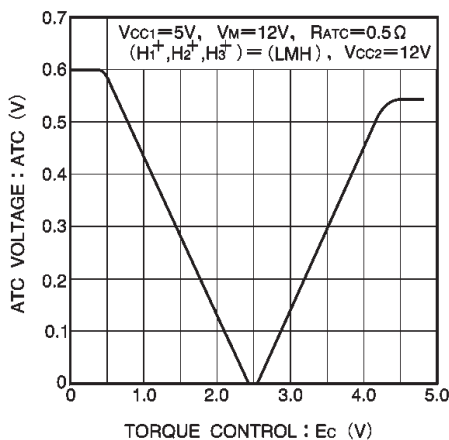

Fig.9 Output current vs. torque control voltage (I)

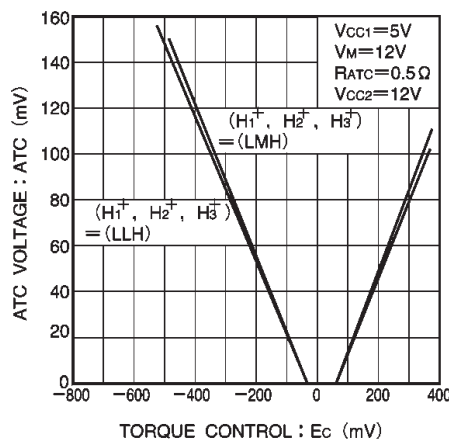

Fig.10 Output current vs. torque control voltage (II)

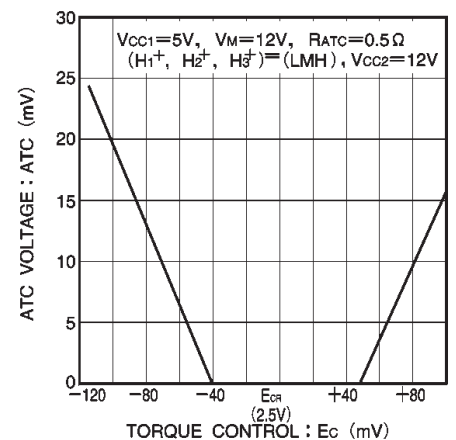

Fig.11 Output current vs. torque control voltage (III)

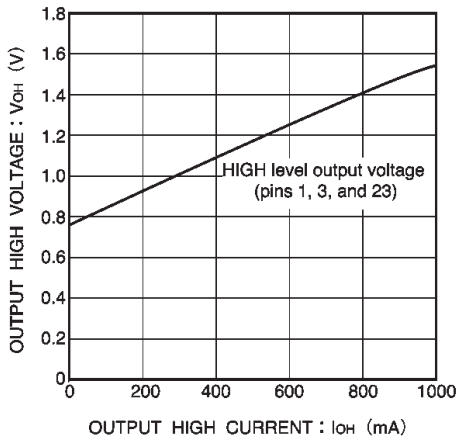

Fig.12 Output high level voltage vs. Output high level current

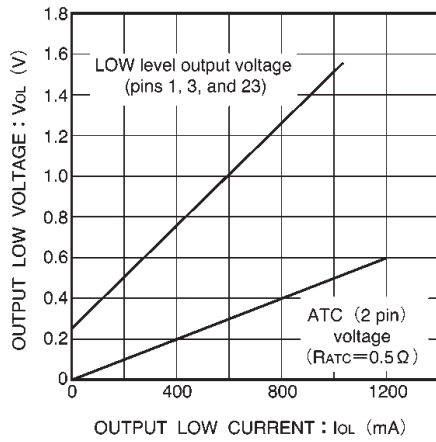

Fig.13 Output low level voltage vs. Output low level current

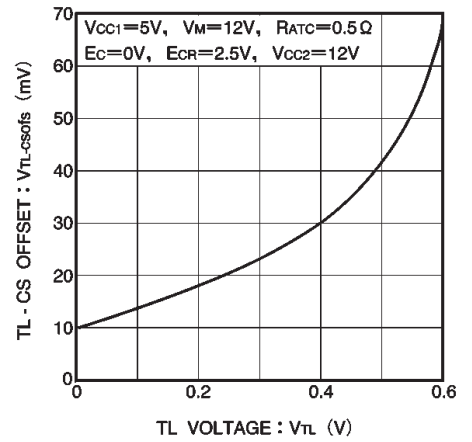

Fig.14 TL-CS offset vs. TL voltage

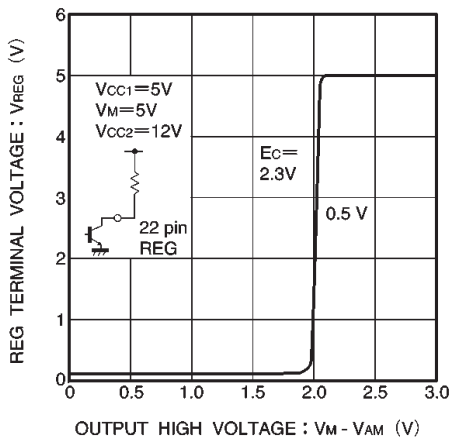

Fig.15 REG-pin voltage vs. output high level voltage

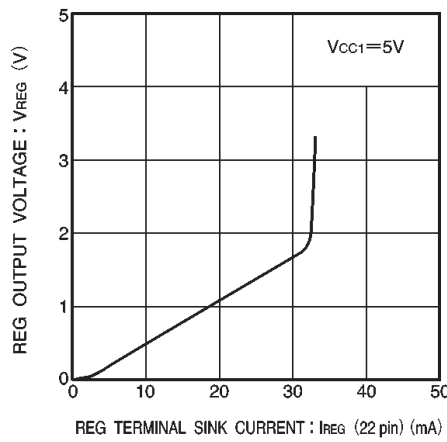

Fig.16 REG-pin output voltage vs. REG-pin sink current

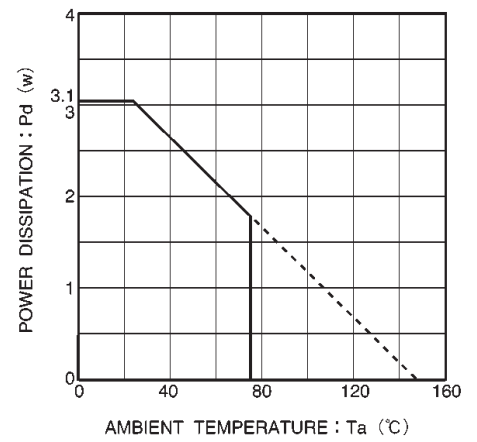

Fig.17 Power dissipation curve

● External dimensions (Units: mm)

