

PBL 388 12

Voice-switch circuit for Handsfree speakerphone TAM

Description

The PBL 388 12 contains all the necessary circuitry, amplifiers, detectors, comparators and control functions to implement a high performance, voice-switched, "hands-free" function in an answering machine. The gain dynamics (attenuation between channels) is settable (25dB or 50dB) via CTR pin that also control two mute levels. A background noise detector in the transmitting channel reduces the influence of continuous noise signals.

The PBL 388 12 is designed for answering machines that are either powered from the telephone line or from a mains powered dc. supply.

Filtering of both the audio and control signals in both transmitter and receiver channels possible.

An external loudspeaker amplifier has to be used, normally the same as used for the answering machine.

All figures in this paper refer to 16-pin SO package.

Key Features

- Settable gain dynamics (25 or 50 dB).
- Low power consumption, totally 1.0mA at 3.3V typical.
- Background noise compensation in the transmitting channel with hold function.
- Excellent noise performance.
- Both channel input amplifiers have balanced inputs.
- Minimum of external components needed for function.
- 16-pin SO and 18-pin DIP encapsulation.

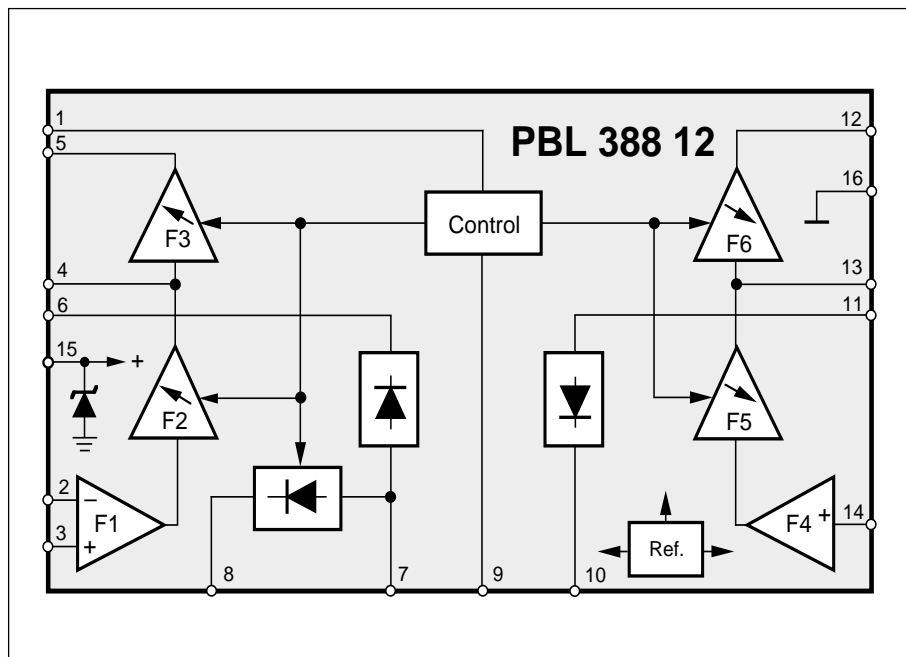
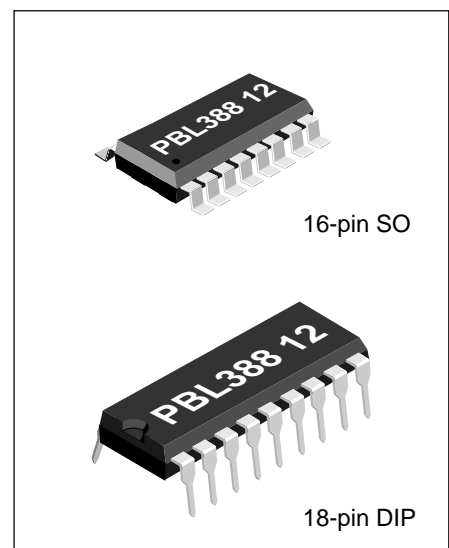

Figure 1. Block diagram. (SO - package)



Maximum Ratings

Parameter	Symbol	Min	Max	Unit
Speech switch supply current	I_D		10	mA
Voltage pin 1-14		-0,5	$V_{pin_{15}}+0.5$	V
Operating temperature	T_{Amb}	-20	+70	°C
Storage temperature	T_{Stg}	-55	+125	°C

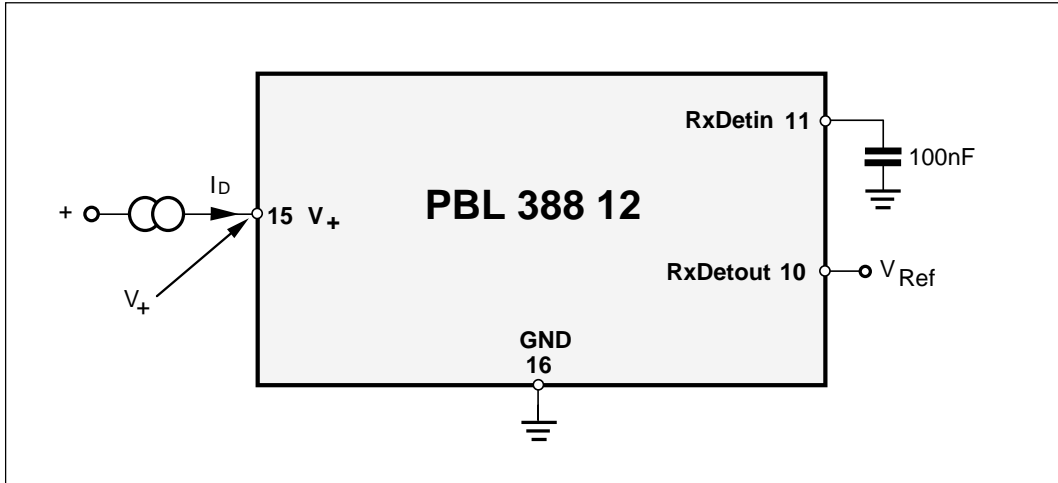

Figure 2. Isolation and measurement of V_{Ref} . Reference figure No.2.

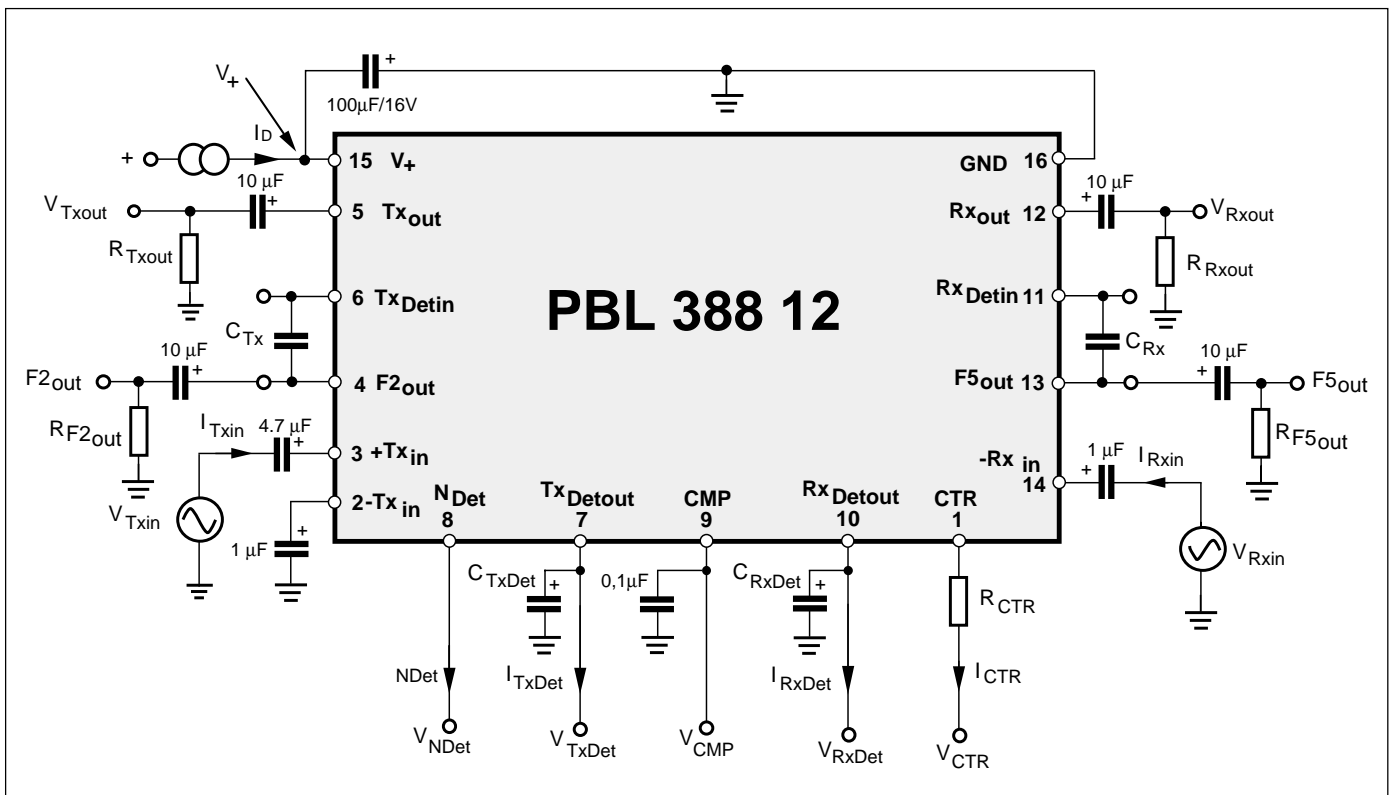

Figure 3. Test circuit. Reference figure No. 3.

Electrical Characteristics

f = 1 kHz, T = 25°C, R_{CTR}=0, C_{TxDet} = 0, R_{Txout} = ∞, R_{Rxout} = ∞, R_{F2out} = ∞, R_{F5out} = ∞, R_{Tx} = 0, R_{Rx} = 0, C_{RxDet} = 0 and I_D=1.0mA unless otherwise noted.

Parameter	Ref. fig.	Condition	Min.	Typ.	Max.	Unit.
Speech control section						
Terminal voltage, V ₊	3	I _D = 1.0mA		3.3		V
Internal reference voltage, V _{Ref}	2			1.96		V
Frequency response for all amplifiers	3	200 - 3400 Hz, Relative 1 kHz	-1		1	dB
Transmit gain, 20 • 10 log(V _{Txout} / V _{Txin})	3	V _{CMP} = V _{Ref} - 0.1 V	41.5	44		dB
		V _{CMP} = V _{Ref} + 0.1 V		-6	-3.5	dB
		V _{CMP} = V _{Ref} - 0.1 V R _{CTR} =100k, V _{CTR} =V+	41.5	44		dB
		V _{CMP} = V _{Ref} + 0.1 V R _{CTR} =100k, V _{CTR} =V+		19	21.5	dB
Receive gain, 20 • 10 log(V _{Rxout} / V _{Rxin})	3	V _{CMP} = V _{Ref} + 0.1 V	26.5	29		dB
		V _{CMP} = V _{Ref} - 0.1 V		-21	-18.5	dB
		V _{CMP} = V _{Ref} + 0.1 V R _{CTR} =100k, V _{CTR} =V+	26.5	29		dB
		V _{CMP} = V _{Ref} - 0.1 V R _{CTR} =100k, V _{CTR} =V+		4	6.5	dB
Max transmit detector gain, 20 • 10 log(V _{Txdet} / V _{Txin})	3	V _{TxDet} < 200 mV _p , C _{Tx} = 100nF		67.5		dB
		V _{CMP} = V _{Ref} - 0.1 V				dB
		V _{CMP} = V _{Ref} + 0.1 V	37	42.5		dB
Max receive detector gain, 20 • 10 log(V _{Rxdet} / V _{Rxin})	3	V _{RxDet} < 200 mV _p , C _{Tx} = 100nF		53		dB
		V _{CMP} = V _{Ref} + 0.1 V				dB
		V _{CMP} = V _{Ref} - 0.1 V	22.5	28		dB
Background noise rectifier gain, (note 1)	3	V _{CMP} = V _{Ref} - 0.1 V, C _{TxDet} =1μF		6.0		dB
		V _{CMP} = V _{Ref} + 0.1 V, C _{TxDet} =1μF		Hold		
+ Tx _{In} input impedance	3		80	100	120	kΩ
- Tx _{In} input impedance	3		2.4	3.0	3.6	kΩ
- Rx _{In} input impedance	3		16	20	24	kΩ
Tx _{Out} ac, load impedance	3		10			kΩ
Rx _{Out} ac, load impedance	3		10			kΩ
F2 _{Out} ac, load impedance	3		10			kΩ
F5 _{Out} ac, load impedance	3		10			kΩ
Transmitter channel output swing, v _{TxOut}	3	2% distortion, R _{Txout} =R _{Rxout} =25k Ω		500		mV _p
Receiver channel output swing, v _{RxOut}	3	2% distortion, R _{Txout} =R _{Rxout} =25k Ω		500		mV _p
Transmitter output noise, v _{TxOut}	3	V _{CMP} = V _{Ref} - 0.1 V, v _{TxIn} = 0 V		-75		dB _{psof}
Receiver output noise, v _{RxOut}	3	V _{CMP} = V _{Ref} + 0.1 V, v _{RxIn} = 0 V		-75		dB _A
Tx _{Det} sink current, I _{TxDetOut}	3	V _{TxDetIn} = V _{Ref} + 0.1 V		-6.0	-2.5	mA
Rx _{Det} source current, I _{RxDetOut}	3	V _{RxIn} = V _{Ref} - 0.1 V	2.5	6.0		mA
Tx _{Det} source current, I _{TxDet}	3	V _{CMP} = V _{Ref} - 0.1 V			30	μA
Rx _{Det} sink current, I _{RxDetOut}	3	V _{RxDetIn} = V _{Ref} + 0.1 V	-30			μA
Tx _{Det} swing relative to V _{Ref} , V _{TxDetOut}	3	V _{TxDetIn} = V _{Ref} + 0.1 V	(note 2)	-0.7		V
Rx _{Det} swing relative to V _{Ref} , V _{RxDetOut}	3	V _{RxDetIn} = V _{Ref} - 0.1 V	(note 2)	+0.7		V
N _{Det} sink current (fast charge), I _{NDet}	3	V _{TxDetIn} = V _{Ref} - 0.1 V		-4.5	-1.5	mA
		V _{CMP} = V _{Ref} - 0.1 V				
N _{Det} source current, I _{NDet}	3	V _{TxDetIn} = V _{Ref} + 0.1 V	3	5	7	μA
		V _{CMP} = V _{Ref} + 0.1 V				

Parameter	Ref. fig.	Conditions	Min.	Typ.	Max.	Unit.
N_{Det} leakage current (hold), I_{NDet}	3	$V_{\text{TxDetIn}} = V_{\text{Ref}} - 0.1 \text{ V}$, $V_{\text{CMP}} = V_{\text{Ref}} + 0.1 \text{ V}$,		-100		nA
N_{Det} swing relative to V_{Ref} , V_{NDet}	3	$V_{\text{CMP}} = V_{\text{Ref}} - 0.1 \text{ V}$, $V_{\text{TxDetIn}} = V_{\text{Ref}} + 0.1 \text{ V}$		-0.45		V
CMP (comparator) sensitivity, transmit (Tx) mode to receive (Rx) mode or vice versa	3 13	Tx mode = max Tx gain, Rx mode = max Rx gain		50	100	mV
CTR voltage for 25 dB dynamics, V_{CTR}	3	$V_{\text{CMP}} = V_{\text{Ref}} \pm 0.35 \text{ V}$, $R_{\text{CTR}} = 100 \text{ k}\Omega$		V_+		V
CTR voltage for mute, I_{CTR}	3	$V_{\text{CMP}} = V_{\text{Ref}} \pm 0.35 \text{ V}$				μA
CTR voltage for disable, V_{CTR}	3				0.55	V

Notes:

$$1. \quad 20 \cdot 10 \log \left(\frac{V_{\text{NDet}} - V_{\text{Ref}}}{V_{\text{TxDet}} - V_{\text{TxDetO}}} \right)$$

V_{NDet} = voltage at noise detector output

V_{Ref} = reference voltage (about 1.9 V) see figure 2.

V_{TxDet} = Voltage at transmit detector output.

V_{TxDetO} = voltage at transmit detector output at the point when the voltage at the noise detector starts moving when a signal at transmit channel input is gradually increased (threshold, typical value 30 mV)

2. Depends on V_+ . Channels are tracking.

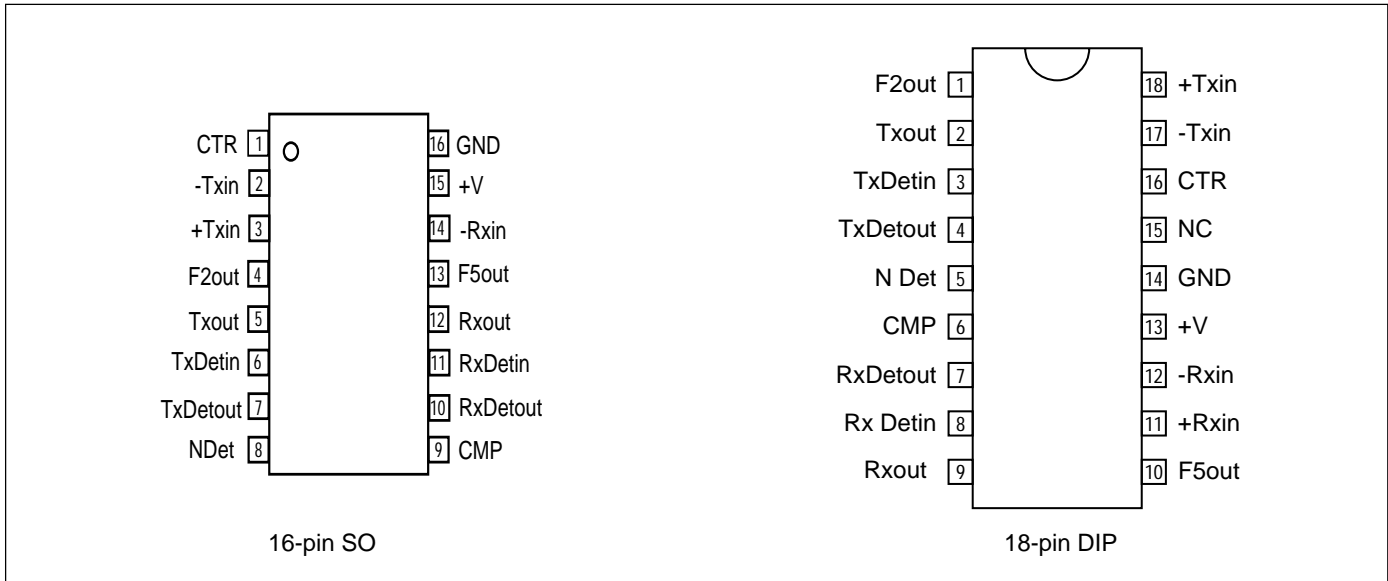

Figure 4. Pin configuration.

Pin Descriptions:

Refer to figure 4. (16-pin SO and 18-pin DIP package)

Pin SO	Pin DIP	Symbol	Description	Pin SO	Pin DIP	Symbol	Description
1	16	CTR	Control input for gain dynamics (25 or 50dB), mute and disable.	9	6	CMP	Comparator input.. Summing point to the different detector outputs.
2	17	-Txin	Transmitter channel negative input. Input impedance 3 kohm.	10	7	RxDetout	Output of the receiver channel signal detector. Goes positive referred to the internal ref. voltage of app. 2V when a receiver signal is present
3	18	+Txin	Transmitter channel positive input. Input impedance 100 kohm.	11	8	RxDetin	Input of the receiver channel signal detector. Input impedance 13 kohm.
4	1	F2out	Output of the second amplifier in the transmitter channel.	12	9	Rxout	Receiver channel output. Min. ac load impedance 10 kohm.
5	2	Txout	Transmitter channel output. Min. ac load impedance 10 kohm.	13	10	F5out	Output of the second amplifier in the receiver channel.
6	3	TxDetin	Input of the transmitter channel signal detector. Input impedance 13 kohm.	11	11	+Rxin	Receiver channel positive input. Input impedance 140 kohm.
7	4	TxDetout	Output of the transmitter channel signal detector. Goes negative referred to the internal ref. voltage of app. 2V when a transmitter signal is present.	14	12	-Rxin	Receiver channel negative input. Input impedance 20 kohm.
8	5	NDet	Background noise detector output. Goes positive referred to the internal ref. voltage of app. 2V when a background noise signal is present	15	13	V+	Supply of the speech switching circuitry. A shunt regulator, voltage appr. 3.3V at 1.0mA.
				16	14	GND	System ground.
				15	15	NC	Not connected.

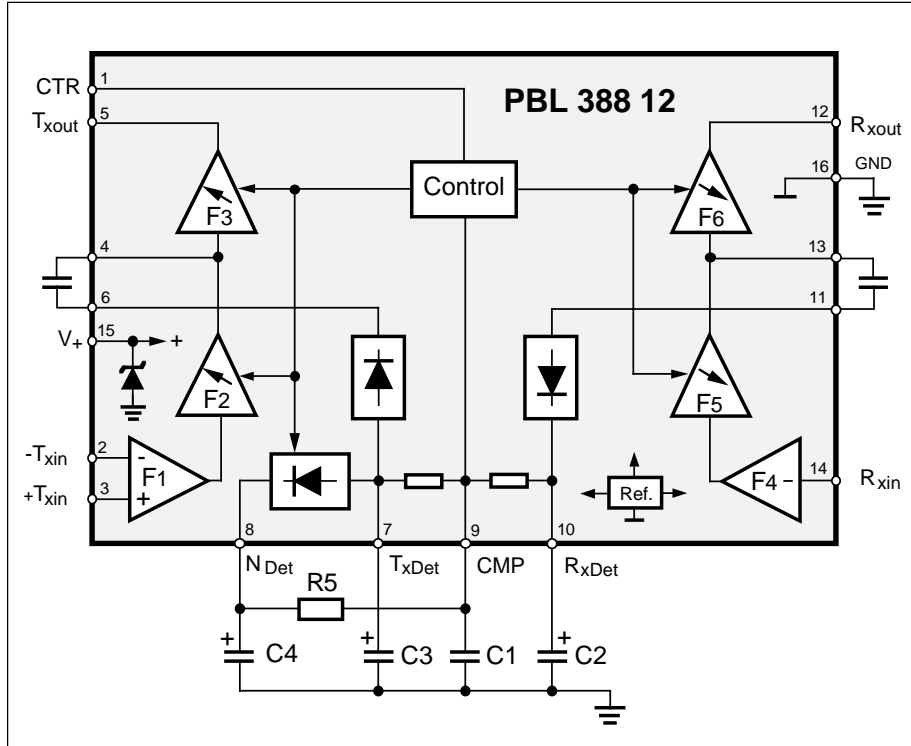

Figure 5. Passive networks setting the speech control function.

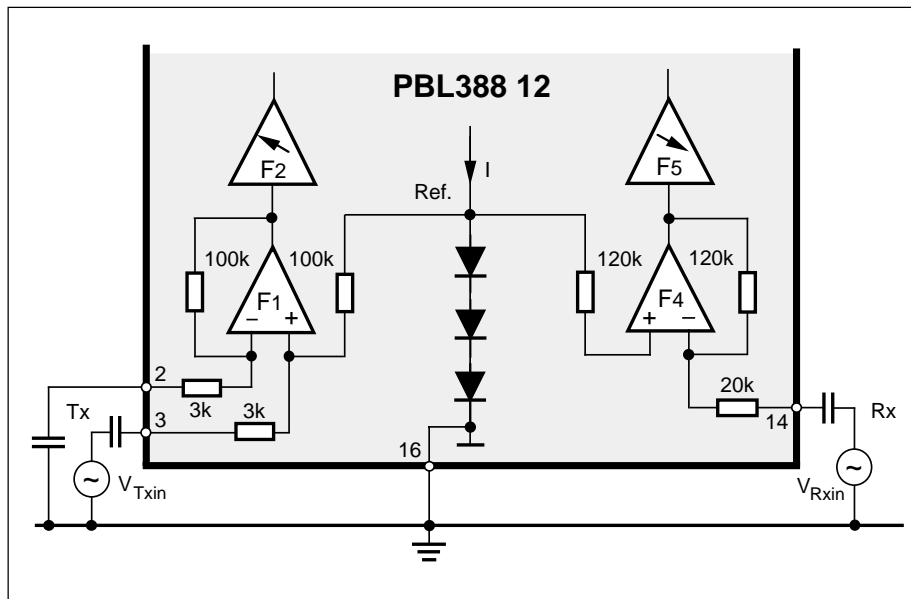

Figure 6. Receiver and transmitter channel input arrangement.

Functional Description Speech control section Transmitter and Receiver Channels

The transmitter and receiver channels consist of three amplifying stages each, F1, F2, F3 and F4, F5, F6. The inputs of the amplifiers must be ac. coupled because they are dc. wise at the internal reference voltage ($\approx 2V$) level. F1 and F4 are fixed gain amplifiers of 30,5 dB and 15.5 dB respectively, while the rest of them are of controlled gain type. The gain of F2, F3 as well as F5 and F6 is controlled by comparators. The comparator receives its information partly from the summing point of the transmitter, receiver and background noise detectors at CMP input and partly through the control input, CTR, which controls the gain dynamics (25 or 50 dB). Amplifiers F2 and F3 have the maximum gain when the transmitter channel is fully open, consequently the amplifiers F5 and F6 will have minimum gain and vice versa. See figure 5 and figure 11.

The positive input on transmitter and the negative input on receiver channel has a rather high input impedance. It renders a good gain precision and noise performance when used with low signal source impedance. The differential input of the transmitter channel can be used to suppress unwanted signals in the microphone supply, see figure 7. Also see application 1.

Signal Detectors and Comparator

The signal detectors sense and rectify the receiver and microphone signals to opposite polarities referenced to the internal reference voltage of approx. 2V. The voltage at RxDet will go positive and at TxDet negative in the presence of a signal at the respective channel input. In the idle (no signal) state, the voltages at RxDet, TxDet and CMP are equal to the internal reference voltage. Signal at Txin will result in an decreasing level at TxDetout and hence also at CMP input.

Figure 7. Transmitter channel input amplifier used to suppress ripple in the mic. supply. (CMRR).

$R1 = R2 \approx 3k$
 $R3 = R4 \approx 100k$
 $R5 = R6$
 $C1 = C2$

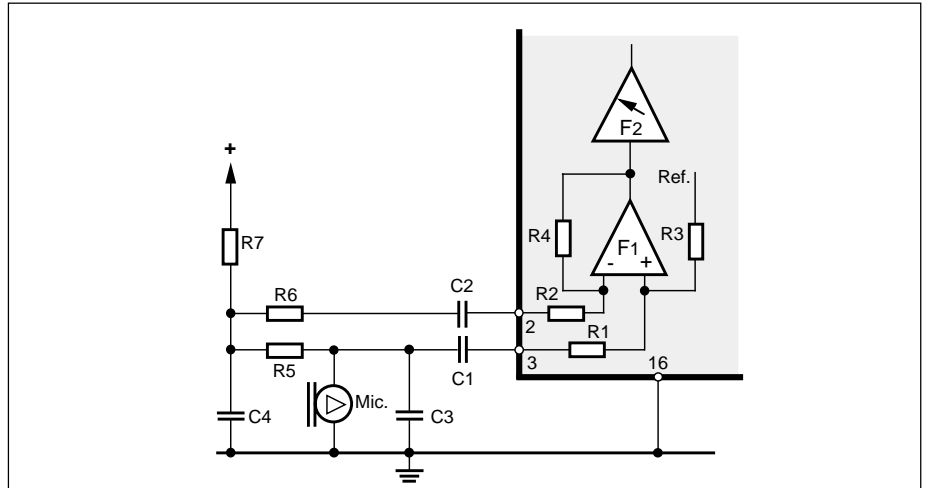

Figure 8. Transmitter and receiver channel rectifier characteristics.

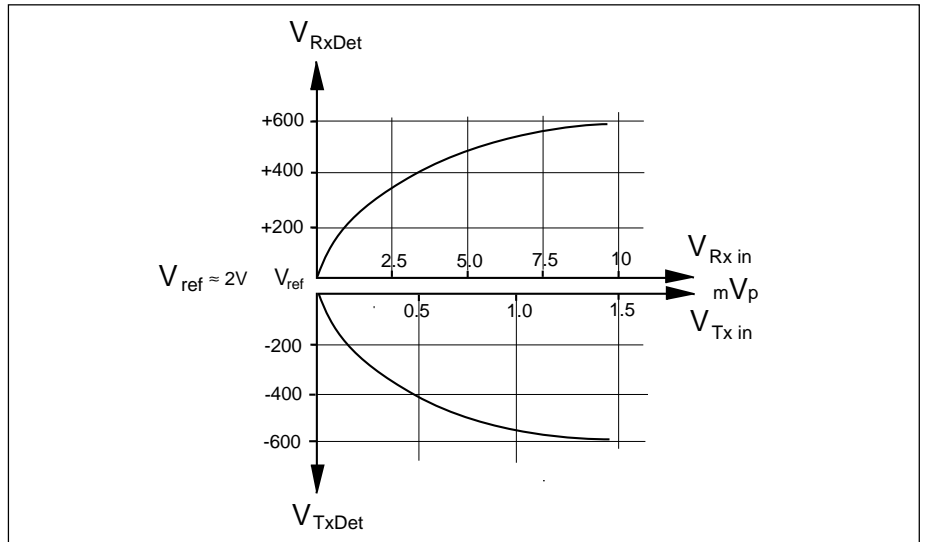

Figure 9. Relationship in timing between the voltage levels at Tx_{in} , Tx_{Det} and N_{Det}

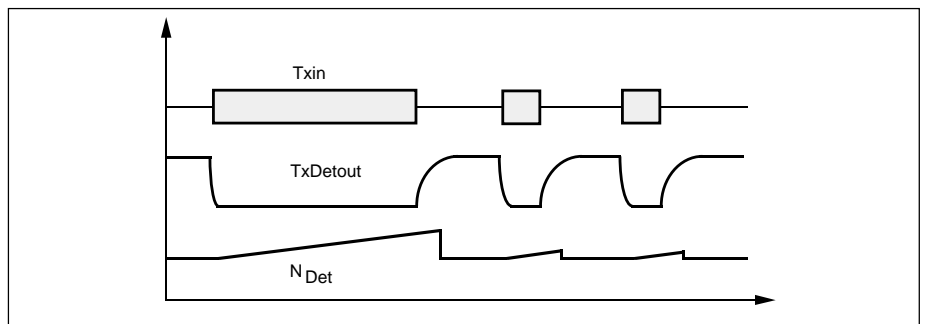
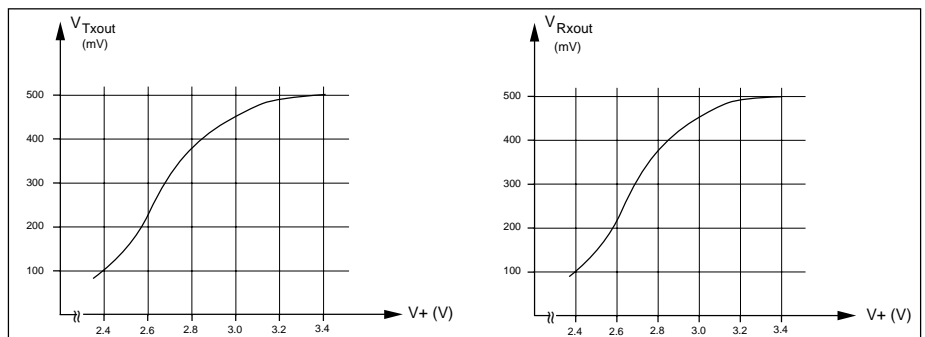

Figure 10. Transmitter and receiver channel output dynamics.



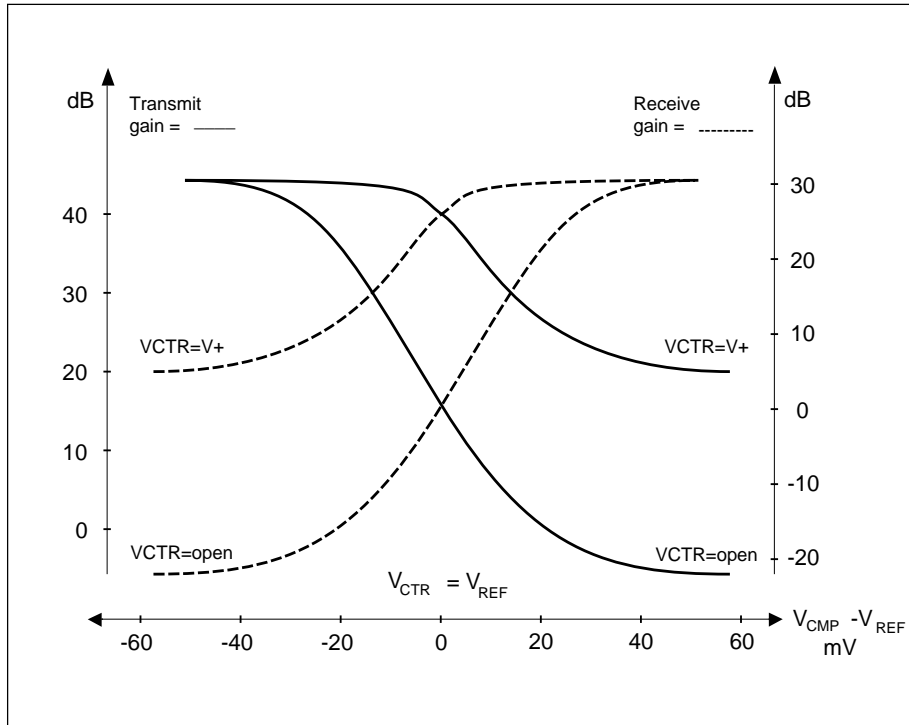

Figure 11. Transmit and receive gain as a function of V_{CMP} and V_{CTR} .

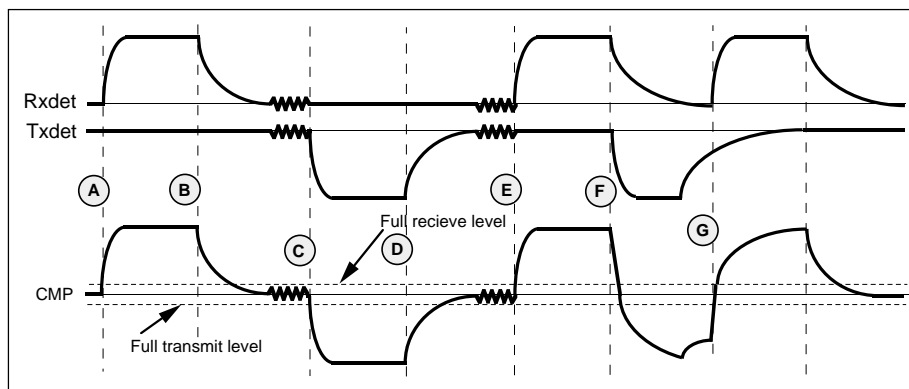

Figure 12. Timing of the transmitter and receiver channels at the CMP-input.

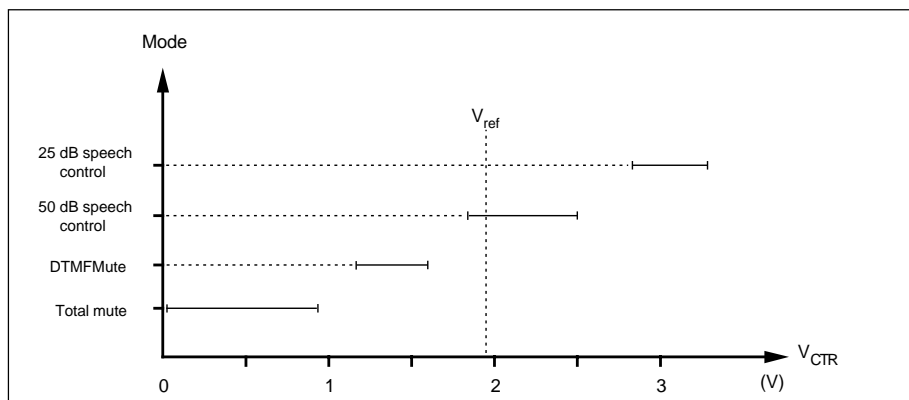

Figure 13. Control modes as function of voltage applied to gain dynamics control input CTR; $I_D=1mA$.

the transmitter channel and decrease it in the receiver channel. Signal at Rxin will do vice versa. The voltages RxDetout and TxDetout control thus the gain setting in respective channel through the comparators using the CMP input as a summing point with an input current of less than $1\mu A$. The attack and decay times for the signals RxDetout and TxDetout are controlled by individual external RC-networks. The attack time in the receiver channel is set by C2 together with C1 and either by the maximum current capability of the detector output or it with R2 added. The transmitter channel works likewise. See fig. 7.

The decay time in the receiver and transmitter channels is set by C2 and C3 respectively. The resistor in the time constant is formed by an internal $200k\Omega$ resistor in parallel with the external resistors R3 and R4 respectively. The influence of eventual R1 and R2 can be omitted.

The text above describes the case when only one channel is open at a time and there is a distinctive pause between signals at receiver and transmitter channel inputs so the circuit will have time to reach its idle state. See fig.14 A) to E). If one of the channels gets an input signal immediately after the signal has disappeared from the other channel input the effective decay time, as the CMP input sees it, will be shorter than in the first case. See fig.14 F) to G). The capacitor C4 at CMP - input sets the speed of the gain change in the transmitter and receiver channels. The capacitors C2 and C3 should be dimensioned for a charging time of 0.5 - 10mS and for a discharge time of 150 - 300 mS. The question of switching times being a highly subjective proposition, is in large dependent of the language being spoken in the system, caused by the varying sound pressure picture of the different languages. A hysteresis effect is achieved in the switching since the level detectors sense the signals after F2 and F5 respectively (F2 and F5 are affected by the gain setting). For example: If the transmitter channel is open (maximum gain), a smaller signal at Txin is enough to keep the channel open than would be necessary to open it when the receiver channel is open. The output swing of the level detectors is matched for variations in the supply voltage. The detectors have

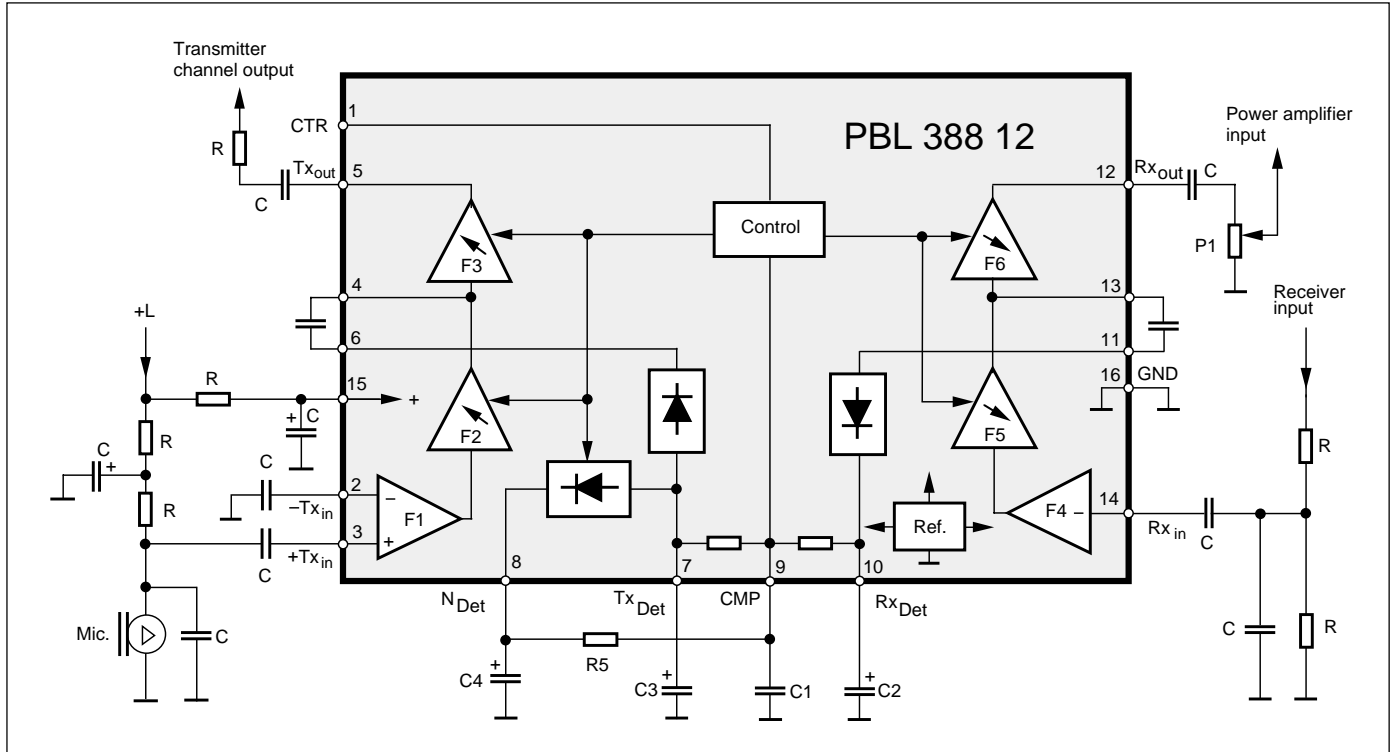

Figure 14. Speech switching arrangement.

a logarithmic rectifier characteristic whereby gain and sensitivity is high at small signals. There is a break point in the curve at a level of $\pm 200\text{mV}$ from the internal reference voltage app. 2V , where the sensitivity for increasing input signals decreases with factor of 10, increasing the detectors dynamic range. See fig.10.

Background Noise Detector

The general function of the background noise detector in the transmitting channel is to create a positive signal (in respect to the reference) so that, when coupled to the summing point at the CMP input, will counteract the signal from the transmitter level detector representing the actual sound pressure level at the microphone. This counteracts the noise from influencing the switching characteristics. The input signal to the background noise level detector is taken from the output of the transmitter detector, a voltage representing the envelope of the amplified microphone signal. The detector inverts and amplifies this signal $2 \times$ (transmitting mode) and has on its output a RC network consisting of an internal resistor of 100k

and an external capacitor C4. The voltage across C4 is connected to the CMP input (summing point) via a resistor R5. The resistor R6 is important in order to keep the charging current of C4 within safe limits in regard of high charge peaks that could be audible in the system. The extent to which the NDet output will influence the potential at CMP input is set by the gain of the detector, the maximum swing and R5. If a continuous input signal is received from the microphone ($> 10\text{sec.}$) the voltage across C4 is pulled negative (relative to the reference) with a time constant set by C4 to e.g. 5sec. A continuous input signal is thus treated as noise. Since the output of the noise detector is going negative it thereby counteracts the signal from the transmitter detector and thus helping the receiver detector signal to maintain a set relation to the transmitter detector signal. If the transmitter input signal contains breaks like breath pauses the voltage at TxDetout decreases. If the voltage across C3 gets less than the inverted voltage across C4 divided by the detector gain a rapid charge of C4 towards reference will follow (all levels referred to the reference). If the breaks are frequent as in speech the background detector will not influence the

switching characteristic of the system. See fig. 11. There is a threshold of approx. 50mV at TxDetout to prevent the activation of background noise detection in noiseless environment. In the receiver mode some of the loudspeaker output signal will be sensed by the microphone. In order not to treat this input signal as noise, the noise detector goes into a hold state and "remembers" the level from the previous transmitting mode period.

CTR Input

For full speech control (50dB attenuation between the channels) this input can be left unconnected. To set the function to 25dB attenuation the input has to be higher than 600mV below $V+$. See figure 13. To set the circuit into a mute state (results in, reduced gain in receiver channel for the DTMF confidence tone in the loudspeaker and closed transmitter channel) a voltage below V_{ref} has to be connected to the input. By lowering the voltage at the input below 0.9V a condition will emerge where both receiver and transmitter channels are closed. See fig. 11 and 15.

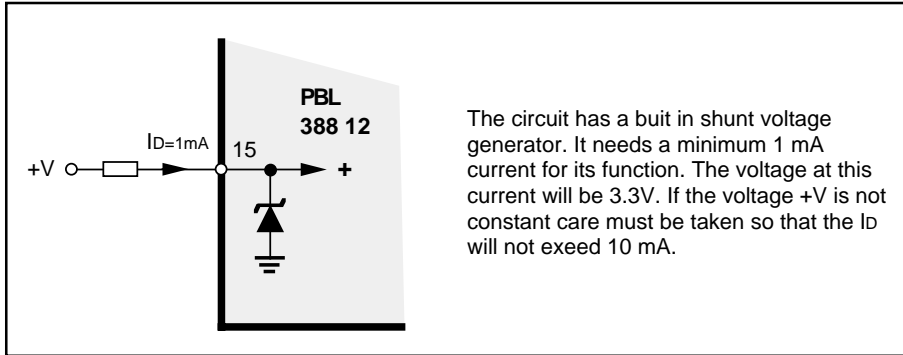

Figure 15. Circuit supply function.

Information given in this data sheet is believed to be accurate and reliable. However no responsibility is assumed for the consequences of its use nor for any infringement of patents or other rights of third parties which may result from its use. No license is granted by implication or otherwise under any patent or patent rights of Ericsson Components AB. These products are sold only according to Ericsson Components AB' general conditions of sale, unless otherwise confirmed in writing.

Specifications subject to change without notice.

1522-PBL 388 12/1 Uen Rev.A

October 1999

© Ericsson Components AB,



Ericsson Components AB
 S-164 81 Kista-Stockholm, Sweden
 Telephone: (08) 757 50 00

Ordering Information

Package	Temp. Range	Part No.
Plastic SO	-20 to 70°C	PBL 388 12/1SO
Plastic SO	-20 to 70°C	PBL 388 12/1SO:T (Tape and Reel)
Plastic DIP	-20 to 70°C	PBL 388 12