

TC55328P/J-17, TC55328P/J-20
 TC55328P/J-25, TC55328P/J-35

T-46-23-14

32,768 WORD x 8 BIT CMOS STATIC RAM

DESCRIPTION

The TC55328P/J is a 262,144 bits high speed static random access memory organized as 32,768 words by 8 bits using CMOS technology, and operated from a single 5-volt supply. Toshiba's CMOS technology and advanced circuit form provide high speed feature.

The TC55328P/J has low power feature with device control using Chip Enable (\overline{CE}), and has Output Enable Input (\overline{OE}) for fast memory access. Also the device power at memory access is reduced by automatic power down circuit form.

The TC55328P/J is suitable for use in cache memory where high speed is required. All Inputs and Outputs are directly TTL compatible.

The TC55328P/J is packaged in a 28 pin standard DIP and SOJ with 300 mil width for high density surface assembly.

FEATURES

- Fast access time:

TC55328P/J-17	17ns(MAX.)
TC55328P/J-20	20ns(MAX.)
TC55328P/J-25	25ns(MAX.)
TC55328P/J-35	35ns(MAX.)
- Low power dissipation

Operation :	TC55328P/J-17	140mA(MAX.)
	TC55328P/J-20	140mA(MAX.)
	TC55328P/J-25	140mA(MAX.)
	TC55328P/J-35	120mA(MAX.)
Standby :		1mA(MAX.)
- 5V single power supply :

-17	: 5V±5%
-20/25/35	: 5V±10%
- Fully static operation
- All Inputs and Outputs : TTL compatible
- Output buffer control : \overline{OE}
- Package

TC55328P	: DIP28-P-300B
TC55328J	: SOJ28-P-300A

PIN CONNECTION

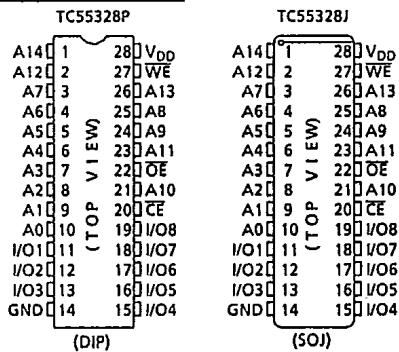

PIN NAMES

A0~A14	Address Inputs
I/O1~I/O8	Data Inputs/Outputs
\overline{CE}	Chip Enable Input
\overline{WE}	Write Enable Input
\overline{OE}	Output Enable Input
V _{DD}	Power (+ 5V)
GND	Ground

BLOCK DIAGRAM

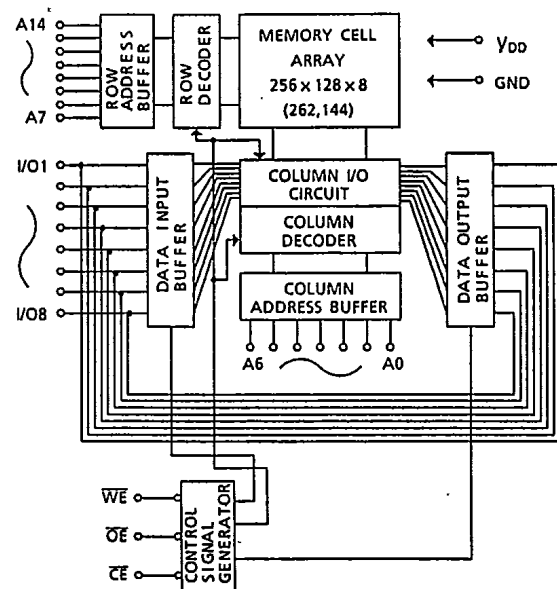

TC55328P/J-17, TC55328P/J-20
TC55328P/J-25, TC55328P/J-35

T-4623-14

MAXIMUM RATINGS

SYMBOL	ITEM	RATING	UNIT
V_{DD}	Power Supply Voltage	-0.5~7.0	V
V_{IN}	Input Voltage	-2.0~7.0	V
V_{IO}	Input / Output Voltage	-0.5~ $V_{DD} + 0.5$	V
P_D	Power Dissipation	1.0	W
T_{solder}	Soldering Temperature · Time	260 · 10	°C · sec
T_{strg}	Storage Temperature	-65~150	°C
T_{opr}	Operating Temperature	-10~85	°C

DC RECOMMENDED OPERATING CONDITIONS ($T_a = 0 \sim 70^\circ\text{C}$)

SYMBOL	PARAMETER	MIN.	TYP.	MAX.	UNIT
V_{DD}	Power Supply Voltage	-17	4.75	5.0	5.25
		-20/25/35	4.5	5.0	5.5
V_{IH}	Input High Voltage	2.2	-	$V_{DD} + 0.5$	V
V_{IL}	Input Low Voltage	-0.5*	-	0.8	V

* -3V Pulse Width : 10ns

DC and OPERATING CHARACTERISTICS ($T_a = 0 \sim 70^\circ\text{C}$, -17: $V_{DD} = 5V \pm 5\%$, -20/25/35: $V_{DD} = 5V \pm 10\%$)

SYMBOL	PARAMETER	TEST CONDITION	MIN.	TYP.	MAX.	UNIT	
I_{IL}	Input Leakage Current	$V_{IN} = 0 \sim V_{DD}$	-	-	± 1	μA	
I_{OH}	Output High Current	$V_{OH} = 2.4V$	-4	-	-	mA	
I_{OL}	Output Low Current	$V_{OL} = 0.4V$	8	-	-	mA	
I_{LO}	Output Leakage Current	$\overline{CE} = V_{IH}$ or $\overline{OE} = V_{IH}$ or $\overline{WE} = V_{IL}$, $V_{OUT} = 0 \sim V_{DD}$	-	-	± 1	μA	
I_{DDO}	Operating Current	t _{cycle} = Min cycle $\overline{CE} = V_{IL}$ Other Input = V_{IH} / V_{IL}	$V_{DD} = 5.25V$	-17	-	-	140
				-20	-	-	140
		$V_{DD} = 5.5V$	-25	-	-	140	
			-35	-	-	120	
I_{DSS1}	Standby Current	t _{cycle} = Min cycle $\overline{CE} = V_{IH}$ Other Input = V_{IH} / V_{IL}	$V_{DD} = 5.25V$	-17	-	-	20
				-20	-	-	20
		$V_{DD} = 5.5V$	-25	-	-	20	
			-35	-	-	20	
I_{DSS2}		$\overline{CE} = V_{DD} - 0.2V$ Other Input = $V_{DD} - 0.2V$ or 0.2V	-	-	1	mA	

CAPACITANCE ($T_a = 25^\circ\text{C}$, $f = 1.0\text{MHz}$)

SYMBOL	PARAMETER	TEST CONDITION	MAX.	UNIT
C_{IN}	Input Capacitance	$V_{IN} = \text{GND}$	6	pF
C_{OUT}	Output Capacitance	$V_{OUT} = \text{GND}$	8	pF

Note: This parameter is periodically sampled and is not 100% tested.

TC55328P/J-17, TC55328P/J-20
TC55328P/J-25, TC55328P/J-35

T-46-23-14

AC CHARACTERISTICS ($T_a = 0 \sim 70^\circ\text{C}$ (1), -17: $V_{DD} = 5V \pm 5\%$, -20/25/35: $V_{DD} = 5V \pm 10\%$)

READ CYCLE

SYMBOL	PARAMETER	TC55328P/J-17		TC55328P/J-20		TC55328P/J-25		TC55328P/J-35		UNIT
		MIN.	MAX.	MIN.	MAX.	MIN.	MAX.	MIN.	MAX.	
t_{RC}	Read Cycle Time	17	-	20	-	25	-	35	-	ns
t_{ACC}	Address Access Time	-	17	-	20	-	25	-	35	
t_{CO}	\overline{CE} Access Time	-	17	-	20	-	25	-	35	
t_{OE}	\overline{OE} Access Time	-	9	-	10	-	12	-	15	
t_{OH}	Output Data Hold Time from Address Change	5	-	5	-	5	-	5	-	
t_{COE}	Output Enable Time from \overline{CE}	5	-	5	-	5	-	5	-	
t_{COD}	Output Disable Time from \overline{CE}	-	10	-	10	-	10	-	15	
t_{OEE}	Output Enable Time from \overline{OE}	0	-	0	-	0	-	0	-	
t_{ODD}	Output Disable Time from \overline{OE}	-	8	-	8	-	10	-	15	
t_{PU}	Chip Selection to Power Up Time	0	-	0	-	0	-	0	-	
t_{PD}	Chip Deselection to Power Down Time	-	17	-	20	-	25	-	35	

WRITE CYCLE

SYMBOL	PARAMETER	TC55328P/J-17		TC55328P/J-20		TC55328P/J-25		TC55328P/J-35		UNIT
		MIN.	MAX.	MIN.	MAX.	MIN.	MAX.	MIN.	MAX.	
t_{WC}	Write Cycle Time	17	-	20	-	25	-	35	-	ns
t_{CW}	Chip Enable to End of Write	13	-	13	-	15	-	20	-	
t_{AS}	Address Set Up Time	0	-	0	-	0	-	0	-	
t_{WP}	Write Pulse Width	13	-	13	-	15	-	20	-	
t_{WR}	Write Recovery Time	0	-	0	-	0	-	0	-	
t_{DS}	Data Set Up Time	10	-	10	-	12	-	15	-	
t_{DH}	Data Hold Time	0	-	0	-	0	-	0	-	
t_{OEW}	Output Enable Time from \overline{WE}	0	-	0	-	0	-	0	-	
t_{ODW}	Output Disable Time from \overline{WE}	-	8	-	8	-	10	-	15	

AC TEST CONDITIONS

Input Pulse Levels	3.0V/0.0V
Input Pulse Rise and Fall Time	3ns
Input Timing Measurement Reference Levels	2.2V/0.8V
Output Timing Measurement Reference Levels	2.0V/0.8V
Output Load	Fig.1

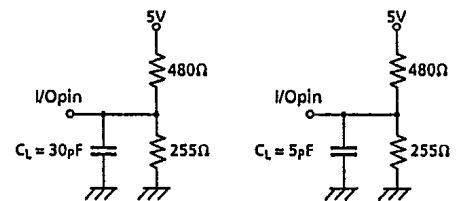
Fig.1

 (For t_{COE} , t_{OEE} , t_{COD} , t_{ODD} , t_{OEW} and t_{ODW})

TC55328P/J-17, TC55328P/J-20
 TC55328P/J-25, TC55328P/J-35

T-46-23-14

TIMING WAVEFORMS

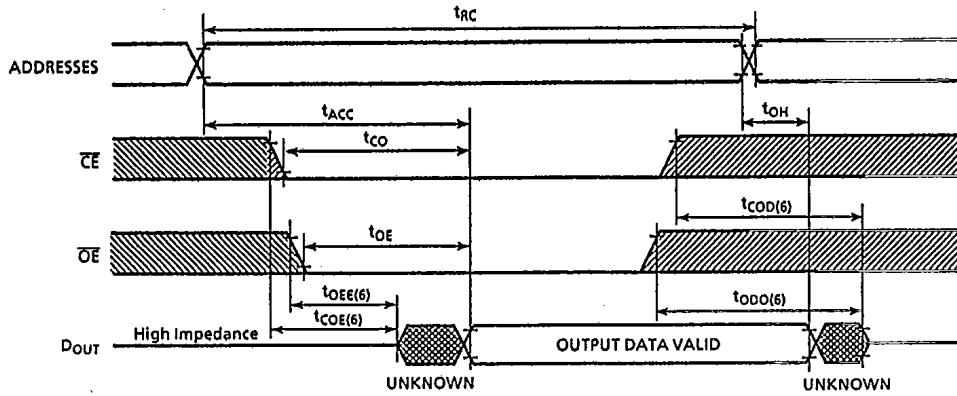
READ CYCLE (2)



WRITE CYCLE1 (5) (\overline{WE} Controlled Write)

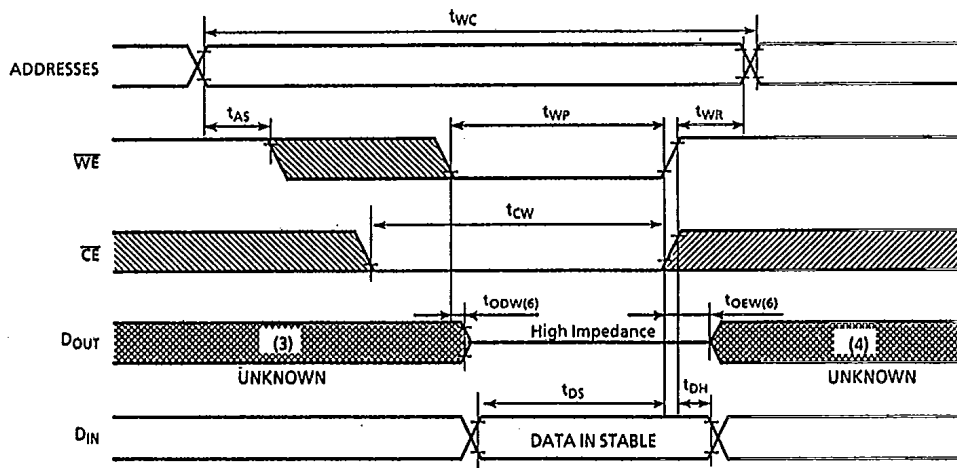

T-46-23-14

WRITE CYCLE2 (5) (\overline{CE} Controlled Write)

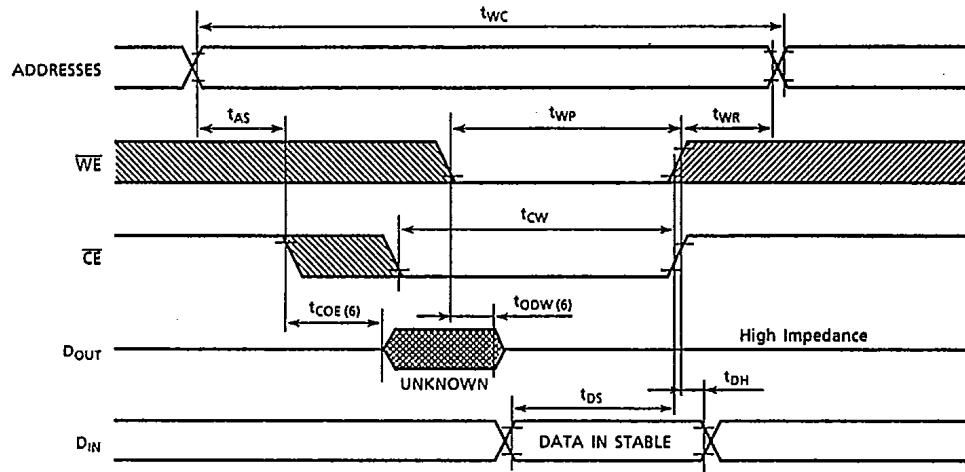

TC55328P/J-17, TC55328P/J-20
 TC55328P/J-25, TC55328P/J-35

T-46-23-14

- NOTE: 1. The operating temperature (T_a) is guaranteed with transverse air flow exceeding 400 linear feet per minute.
2. \overline{WE} is High for Read Cycle.
3. Assuming that \overline{CE} Low transition occurs coincident with or after \overline{WE} Low transition, Outputs remain in a high impedance state.
4. Assuming that \overline{CE} High transition occurs coincident with or prior to \overline{WE} High transition, Outputs remain in a high impedance state.
5. Assuming that \overline{OE} is High for Write Cycle, Outputs are in a high impedance state during this period.
6. These parameters are specified as follows and measured by using the load shown in Fig.1.
- (A) t_{COE} , t_{OEE} , $t_{OE\overline{W}}$ Output Enable Time
- (B) t_{COD} , t_{ODO} , $t_{OD\overline{W}}$ Output Disable Time

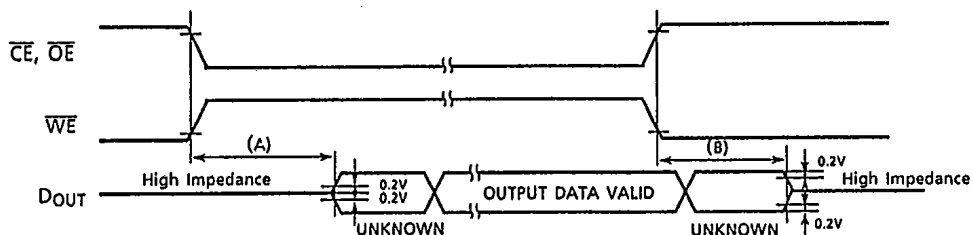

T-46-23-14

OUTLINE DRAWINGS

Plastic DIP (DIP28 - P - 300B)

UNIT in mm

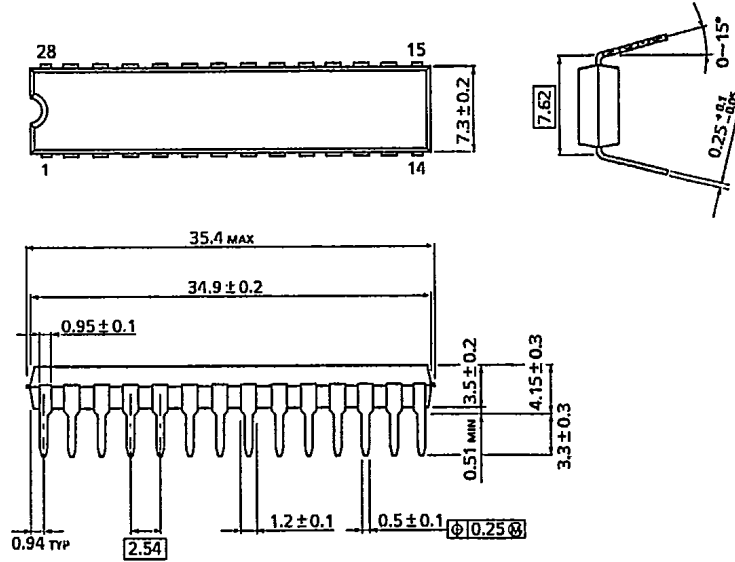

WEIGHT : 2.03g (Typ.)

T-46.23.14

OUTLINE DRAWINGS

Plastic SOJ (SOJ28-P-300A)

UNIT in mm

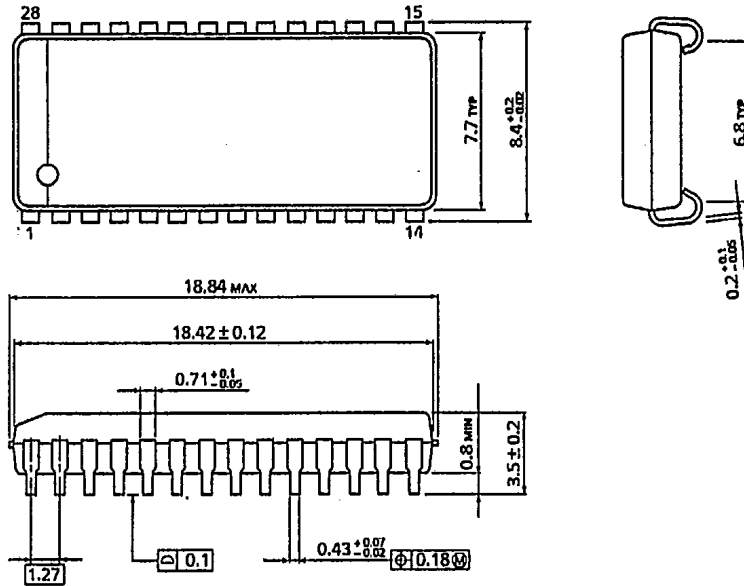

WEIGHT : 0.83g (Typ.)