

# PBL 3781, PPB 3781/02 Low Voltage Speech Circuit

## Description

The PBL 3781 and PBL 3781/02 are bipolar integrated speech circuits for use in electronic telephones. The circuits are designed to operate at low supply voltages, down to 1.3 V, making them usable when connected in parallel with other telephones.

A differential-input microphone amplifier, permits the use of a dynamic microphone. Electret microphones (with built-in FET buffer amplifiers) may also be used.

Gain regulation circuitry provides compensation for loop losses in both the transmit and receiver amplifiers.

The receiver amplifier has a balanced push-pull output stage for good driving capabilities even at low supply voltages.

The PBL 3781 is made to drive low impedance receivers. PBL 3781/02 has a higher impedance to the line.

A straight-forward design procedure simplifies adaptation of the circuit to suit different transducers and battery feeding systems.

## Key Features

- Low voltage operation, down to 1.3 V DC.
- AC voltage swing down to 0.4 V.
- Transmit and receive gain regulation for automatic loop loss compensation.
- Differential microphone input for dynamic microphone.
- Current generator output powers electret buffer amplifier or pulse dialler.
- Balanced receiver output stage.
- 16-pin "batwing" DIP handles 1.5 W power dissipation.
- 20-pin small outline package handles 1.3 W power dissipation.

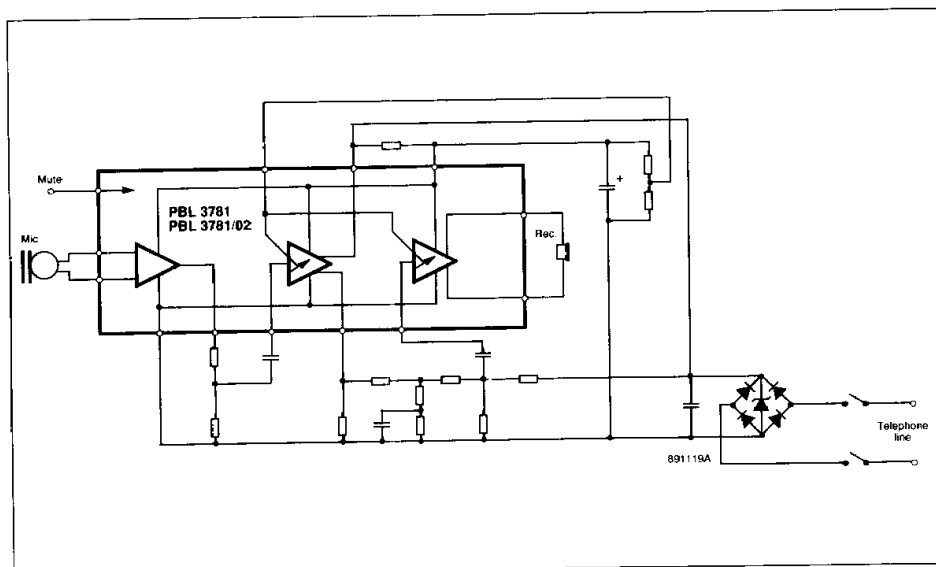
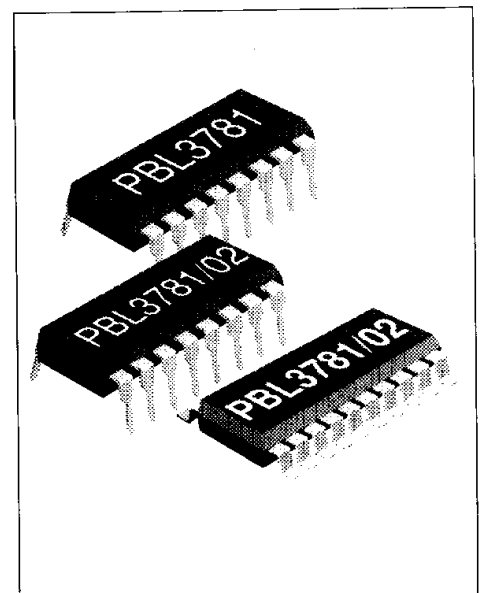

Figure 1. Functional diagram.



### Maximum Ratings

Parameter	Symbol	Min	Max	Unit
Line current, $T_{Amb} = 70\text{ }^\circ\text{C}$				
Dual-in-line package	$I_L$		150	mA
Small Outline package	$I_L$		130	mA
Line voltage				
continuous	$V_L$		15	V
$t_p = 2\text{ s}$	$V_L$		18	V
$t_p = 10\text{ ms}$	$V_L$		20	V
Power dissipation, $T_{Amb} = 70\text{ }^\circ\text{C}$				
Dual-in-line package			1.5	W
Small outline package			1.3	W
Operating temperature range	$T_{Amb}$	-20	+70	$^\circ\text{C}$
Storage temperature range	$T_{Stg}$	-55	+125	$^\circ\text{C}$

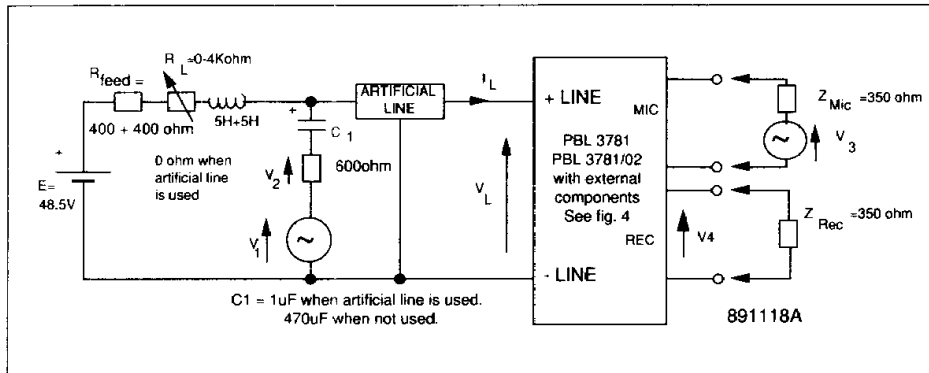

Figure 2. Test setup without rectifier bridge.

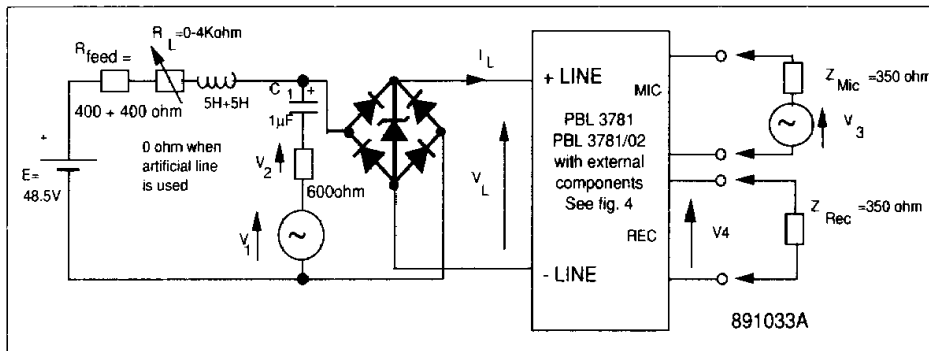

Figure 3. Test setup with rectifier bridge.

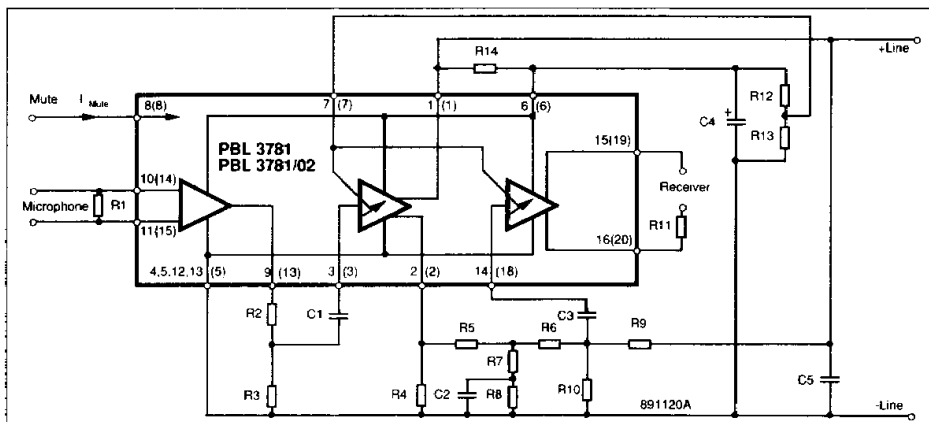

Figure 4. PBL 3781 with external components for test circuits in figures 2 and 3.

- $R1 = 1.8\text{ k}\Omega$
- $R2 = 9.6\text{ k}\Omega$
- $R3 = 3.9\text{ k}\Omega$
- $R4 = 75\text{ }\Omega$
- $R5 = 240\text{ }\Omega$
- $R6 = 6.2\text{ k}\Omega$
- $R7 = 47\text{ }\Omega$
- $R8 = 800\text{ }\Omega$
- $R9 = 62\text{ k}\Omega$
- $R10 = 11\text{ k}\Omega$
- $R11 = 310\text{ }\Omega$
- $R12 = 47\text{ k}\Omega$
- $R13 = 39\text{ k}\Omega$
- $R14 = 900\text{ }\Omega$  (3781)  
 $= 830\text{ }\Omega$  (3781/02)
- $C1 = 150\text{ nF}$
- $C2 = 0.22\text{ }\mu\text{F}$
- $C3 = 47\text{ nF}$
- $C4 = 68\text{ }\mu\text{F}$
- $C5 = 15\text{ nF}$

**Electrical Characteristics**

$T_{Amb} = 25\text{ }^{\circ}\text{C}$  . Measured using test circuit of fig. 1 and 2 without artificial cable, unless otherwise noted.

Parameter	Ref fig	Conditions	Min	Typ	Max	Unit
<b>DC-characteristics</b>						
Line voltage, $V_L$	2	$R_4 = 47\text{ ohm}$ $I_L = 2.5\text{ mA}$		1.3		V
	2	$I_L = 10\text{ mA}$		3.3		V
	2	$I_L = 100\text{ mA}$		8.5		V
	2	$R_4 = 75\text{ ohm}$ $I_L = 2.5\text{ mA}$		1.5		V
	2	$I_L = 10\text{ mA}$		3.5		V
	2	$I_L = 100\text{ mA}$		11.3		V
Maximum Transmitting gain, $V_2, V_3$	2	$20 \times 10 \log (V_2/V_3)$ , $f = 1\text{ kHz}$ $R_L = 0\text{ ohm}$ , $R_2 = 0\text{ ohm}$ , $R_3 = \infty$ , $R_4 = 47\text{ ohm}$		57		dB
	2	$R_L = 900\text{ ohm}$ , $R_2 = 0\text{ ohm}$ , $R_3 = \infty$ , $R_4 = 47\text{ ohm}$		62		dB
Transmitting gain, $V_2, V_3$		$20 \times 10 \log (V_2/V_3)$ $f = 1\text{ kHz}$ , (adjustable with R2 & R3)				
	2	$R_L = 0\text{ ohm}$	41	43	45	dB
	2	$R_L = 400\text{ ohms}$	43.5	45.5	47.5	dB
	2	$R_L = 900\text{ ohms}$	46	48	50	dB
Transmitting gain, range of regulation	2	$f = 1\text{ kHz}$ , $R_L = 0\text{ to }900\text{ ohms}$	3	5	7	dB
Transmitting frequency response	2	200-3400 Hz	-1		+1	dB
Maximum receiving gain, $V_4, V_1$	2	$20 \times 10 \log (V_4/V_1)$ , $f = 1\text{ kHz}$				
	2	$R_L = 0\text{ ohm}$ , $R_{10} = \infty$		-8		dB
	2	$R_L = 900\text{ ohm}$ , $R_{10} = \infty$		-3		dB
Receiving gain, $V_4, V_1$		$20 \cdot 10 \log (V_4/V_1)$ $f = 1\text{ kHz}$ , (Adjustable with R10)				
	2	$R_L = 0\text{ ohm}$	-18.5	-16.5	-14.5	dB
	2	$R_L = 400\text{ ohms}$	-16	-14	-12	dB
	2	$R_L = 900\text{ ohms}$	-13.5	-11.5	-9.5	dB
Receiving gain range of regulation	2	$f = 1\text{ kHz}$ , $R_L = 0\text{ to }900\text{ ohms}$	3	5	7	dB
Receiving frequency response	2	200-3400 Hz	-1		+1	dB
Input impedance microphone amplifier	2,4	$f = 1\text{ kHz}$		2.5//1.8		kohms
Transmitter dynamic output level, $V_2$	2	200-3400 Hz, THD $\leq 2\%$ , $I_L = 20\text{-}100\text{ mA}$		1.5		$V_{Peak}$

Figure 5. DC-current to external microphone amplifier.

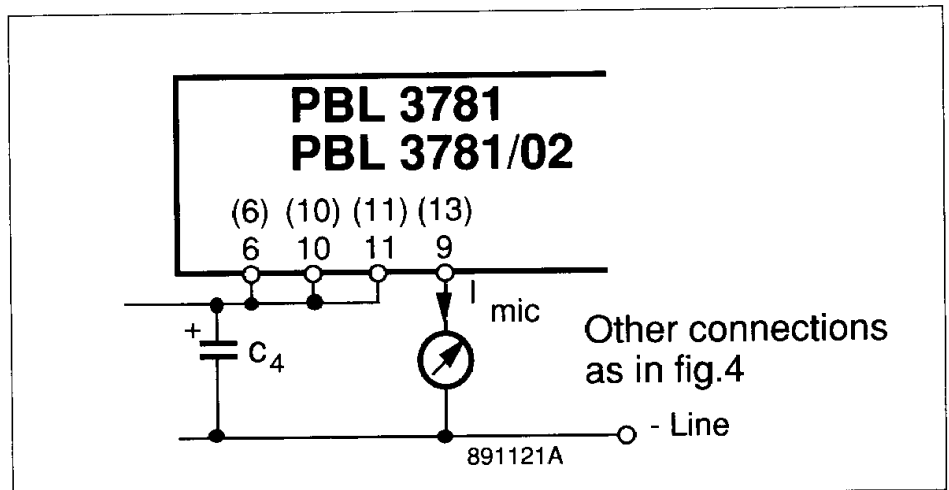

Parameter	Ref fig	Conditions	Min	Typ	Max	Unit
Transmitter maximum output level, $V_2$	2	200-3400 Hz, $I_L = 0-100$ mA, $V_3 = 0-1$ V		3.5		$V_{Peak}$
Receiver output impedance	2, 4	$f = 1$ kHz		6 (+310)		ohms
Receiver dynamic output level, $V_4$	2	200-3400 Hz, THD $\leq 2\%$ , $I_L = 20-100$ mA		0.5		$V_{Peak}$
Receiver maximum output level, $V_4$	3	200-3400 Hz, $I_L = 0-100$ mA, $V_1 = 0-50$ V		1		$V_{Peak}$
Transmitter noise level, $V_2$	2	Psophometric weighted relative to $1 V_{rms}$ , $R_L = 0$		-70		dB
Receiver noise level, $V_4$	2	A-weighted, relative to $1 V_{rms}$ , with artificial cable: 0-5 km, $\varnothing = 0.5$ mm 0-3 km, $\varnothing = 0.4$ mm		-80		dB
DC current to external microphone amplifier, $I_{Mic}$	5	Pins 10 and 11 to pin 6 $I_L = 10-150$ mA, DC-current at pin 9	300			$\mu A$
Mute current, $I_{Mute}$	4	$I_L = 10-150$ mA	100			$\mu A$

**Warning:** It is important to use a receiver which is not too sensitive. Otherwise the internal clipping will not function properly, and acoustic shocks may cause permanent damage to the human ear.

**Pin Descriptions**

Ref. fig 3 and 5.

DIP	S/O	Name	Description
1	1	+L	Output of the DC-regulator and transmit amplifier. This pin is connected to the line through a polarity guard diode bridge.
2	2	TO	Output of the transmit amplifier. This pin is connected to a resistor R4 of 47 ohms to 100 ohms to -L, which sets the DC series-resistance of the circuit. The output has a low AC output impedance, and the signal is used to drive a sidetone balancing network R5, R7, R8 and C2.
3	3	TI	Input of the transmit amplifier.
4, 5, 12, 13	5	-L	The negative power terminal, connected to the line through a polarity guard diode bridge.
6	6	+C	This pin is the positive power supply terminal for most of the circuitry inside the PBL 3781 (about 1 mA current consumption). The majority of the line current however, passes through the TO and +L pins (see above). The +C pin shall be connected to a decoupling capacitor, C4 of 47 to 150 uF.
7	7	GR	This pin is control input for the gain regulation circuitry.
8	8	MUTE	The MUTE input which requires min. 100 µA, to mute the microphone and receiver amplifiers.
9	13	MO	Output of the microphone amplifier. When electret microphones are used, this pin can be connected as a current generator output. See functional description for pins 10 and 11 below.
10	14	MI1	Inputs of the microphone amplifier. The input impedance at these pins is approx. 2.5 kohms. Connecting pins 10 and 11 to pin 6, (+C) switches pin 9 (MO) to a current generator output, that sources about 300 µA for an external electret buffer amplifier.
11	15	MI2	
14	18	RI	Input of receiver amplifier. Input impedance is approx. 35 kohms.
15, 16	19, 20	RE1, RE2	Receiver amplifier output. The output is intended to drive low impedance receivers.
4, 9, 10, 11, 12, 16, 17		NC	Not connected

Figure 6 Pin configuration. 16 -pin DIP and 20-pin SO package.

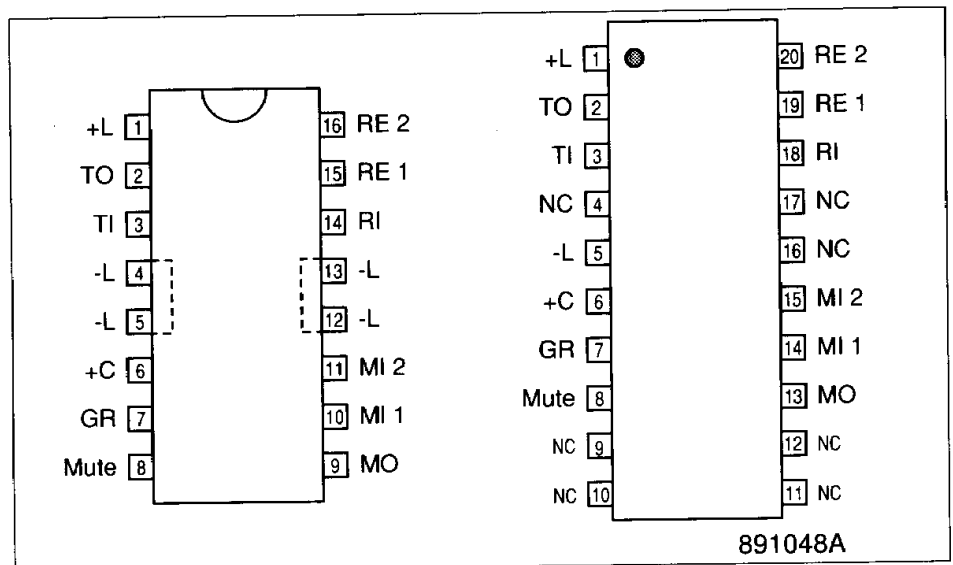

### Functional Description

The PBL 3781, PBL 3781/02 contains a DC-regulator, a microphone amplifier, a transmit amplifier and a receiver amplifier.

The DC-regulator determines the voltage/current characteristics of the circuit. Looking from the line, the circuit acts as a reference voltage of approx. 2.5 Volts in series with a resistor (externally set). The voltage reference is derived from a bandgap reference, which provides for temperature-stable DC-characteristics. To maintain operation even when the line voltage (inside polarity guard diode bridge) drops below 2.5 Volts, the circuit automatically switches to a lower reference voltage.

A microphone amplifier with a differential input stage, and hence good common mode rejection, is provided for low-sensitivity magnetic or dynamic microphones.

The transmit amplifier receives its input signal either from the microphone amplifier or from a separate electret buffer amplifier (that can be powered directly from the circuit). The transmit output stage contains the previously described DC-regulator. The AC-gain is regulated with the line length (selectable), and the

output level is amplitude limited to eliminate sidetone distortion at high transmitting levels.

The sidetone cancellation (or hybrid function) works as follows: A signal, opposite in phase from the transmit signal on the line, is taken from the transmit amplifier and fed through a sidetone balancing network into the summing junction of the receiver amplifier. The (inverted) signal from the line is added, and sidetone cancellation occurs. Only the receive signal, is left at the input of the receiver amplifier.

The AC-gain of the receiver amplifier is regulated with the line length. The output from the receiver amplifier is intended to drive low-impedance (3781 down to 150 ohms, 3781/02 down to 200 ohms) receivers. An internal clipping network limits the signal to the receiver, and prevents acoustic shocks.

PBL 3781, PBL 3781/02 and associated components in a basic telephone speech network. To complete an electronic telephone, the circuit needs to be supplemented by a tone ringer and a DTMF or pulse dialler circuit.

When proceeding through a design, some of the circuit adjustments will interact with each other. It is therefore recommended to adjust the parameters in the following order:

1. Impedance to the line.
2. DC-characteristics.
3. Microphone selection, transmitting gain and frequency response.
4. Gain regulation.
5. Side-tone level, receiving gain and frequency response.

### Impedance to the line

The output impedance of the circuit is determined by R14 in parallel with C5. R14 is normally set to a value between 600 and 900 ohms to satisfy the return loss requirements. R14 also supplies the operating current for the majority of the circuit inside PBL 3781, PBL 3781/02.

It is recommended to select a value near 900 ohms, in order to maximize the available output level from the transmit

### Applications Information

The PBL 3781, PBL 3781/02 is a flexible circuit designed to meet specifications from telephone administrations all over the world. Adaptation to different battery feeding systems and transducers is made by selecting the values of a few external components. Figure 7 shows the

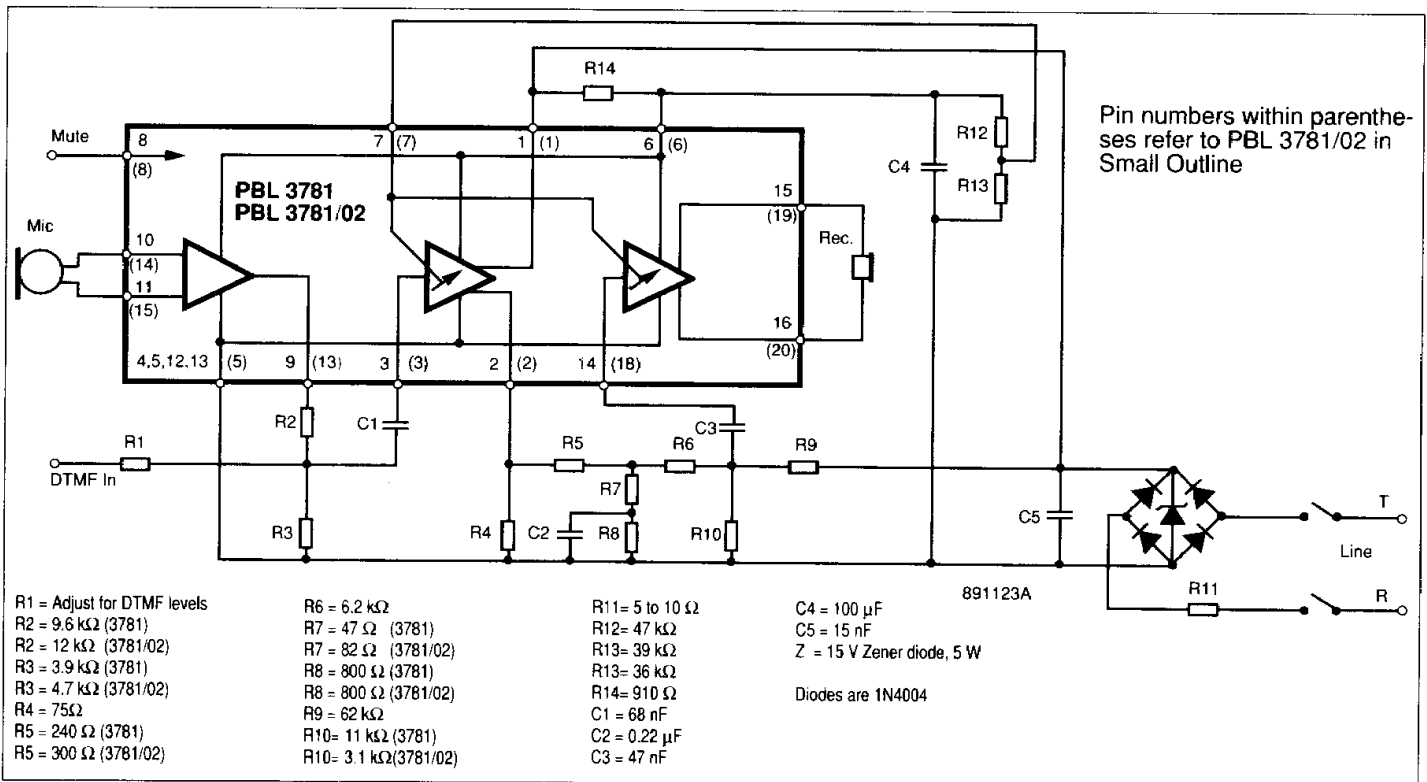

Figure 7. Basic application for 48V/2 X 400 ohms battery feeding system and dynamic microphone and receiver.

amplifier. A lower value of R14 requires a larger capacitor C4 for the stabilization of the supply voltage at pin 6. C5 should be located near the circuit to effectively suppress any radio interference pick-up.

**DC-characteristics**

The DC-behavior is adjusted by resistor R4, which determines the slope of the V-I curve. For line currents above 10 mA, the circuit acts as a series combination of R4 and a zenar diode of approx 2.5 volts.

The minimum working voltage is approximately 1.3 volts, which corresponds to about 2.5 mA line current with R4=47 ohms.

R4 should be selected to give a safe operating point at very short loops. A low value results in excessive current through the circuit, while a larger resistance may raise the voltage above the maximum rated. Suitable values of R4 ranges from 47 to 100 ohms depending on the battery feeding system.

**Microphone selection, transmitting gain and frequency response**

The microphone amplifier section is intended for low-sensitivity dynamic microphones and provides about 26 dB voltage gain. A differential input stage (pins 10/14 and 11/15) gives a good common mode rejection.

The total transmitting gain is adjusted by a resistive attenuator R2 and R3. Capacitor C1 is inserted to give a low-frequency cut-off in the transmit path. The values of R2 and R3 should be selected to present about 3 kohms source impedance for the transmit amplifier input at pin 3.

The transmit amplifier has a current

generator output which means that the voltage gain is partly determined by the ratio between R14 in parallel with the line impedance and R4. The voltage gain from the input at pin 3 to the output (pin 1) varies approximately between 32 and 37 dB over the regulation range with R14 = 900 ohms, R4=47 ohms and a line impedance of 600 ohms. The available gain is therefore enough to enable an electret microphone to be connected directly to pin 3. In such case, it is necessary to utilize the current generator at pin 9/13 to feed the electret buffer amplifier since the transmit amplifier itself is not affected by the MUTE input. The current generator at pin 9/13, which is switched off when the circuit is muted, is selectable by tying pins 10/14 and 11/15 to pin 6. Another method of interfacing an electret microphone is shown in figure 9.

**Gain regulation**

Automatic gain regulation circuitry in the transmit and receiver amplifiers reduces the gain with the loop length when it decreases, see figure 8. The control voltage for the gain regulation is fed into pin 7. By changing the resistive attenuator consisting of R12 and R13, it is possible to shift the location of the regulation curve to get a correct compensation in different battery feeding systems. The slope of the curve is determined by R4. Gain regulation can be cut off completely by tying pin 7 to ground (pins 4, 5, 12, 13 in DIP and (5) in Small Outline.

**Side-tone level, receiving gain and frequency response**

Side-tone cancellation occurs at the input of the receiver amplifier (pin 14/18)

which receives opposite-phased transmit signals from the line and the side-tone network respectively.

Resistor R5 and the actual balancing network consisting of R7, R8 and C2, simulates a first order approximation of the output impedance of the circuit and the line impedance. A practical sequence for determining the component values in the side-tone network is given below. Observe that some iterations and experimental work has to be carried out to find an optimum solution.

1. The value of R5 choose two to four times the value of R4.
2. R7, R8 and C2 should simulate the amplitude and phase response of the line impedance seen at the line terminals. The impedance level of the balancing network should be about one tenth of the line impedance. The values given in figure 7 is good starting point in most cases.
3. The ratio between R6 and R9 should be set to make the signals coming from the line and from the side-tone network equal in amplitude so that cancellation occurs. The value of R6 should be about an order of magnitude larger than the impedance level of the balancing network.
4. R10 is selected to give the desired receiving gain.
5. Steps 2 to 4 above may have to be repeated to give the required side-tone level and receiving gain.

The coupling capacitor C3 is needed for low-frequency cut-off in the receiving amplifier. The input impedance at pin 14/18 is approximately 35 kohms. A balanced push-pull output stage provides good driving capabilities even at low supply voltages. The circuit is intended to drive low-impedance (3781 down to 150 ohm, 3781/02 down to 200 ohm) receivers. High-inductance magnetic receivers may require a series resistor to define a correct driving impedance.

Internal clamping diodes in the output stage prevent excessive acoustic levels which may cause damage to the listener's ear.

**Tone dialling telephone**

Figure 9 shows a tone dialling telephone based on the PBL 3781, PBL 3781/02 and a CMOS DTMF IC. The DTMF circuit operates in parallel with the

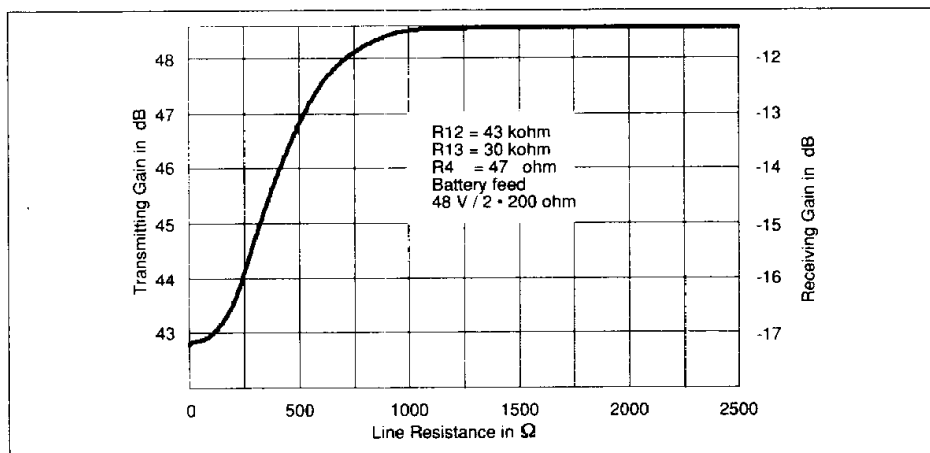

Figure 8. Typical gain regulation curve.

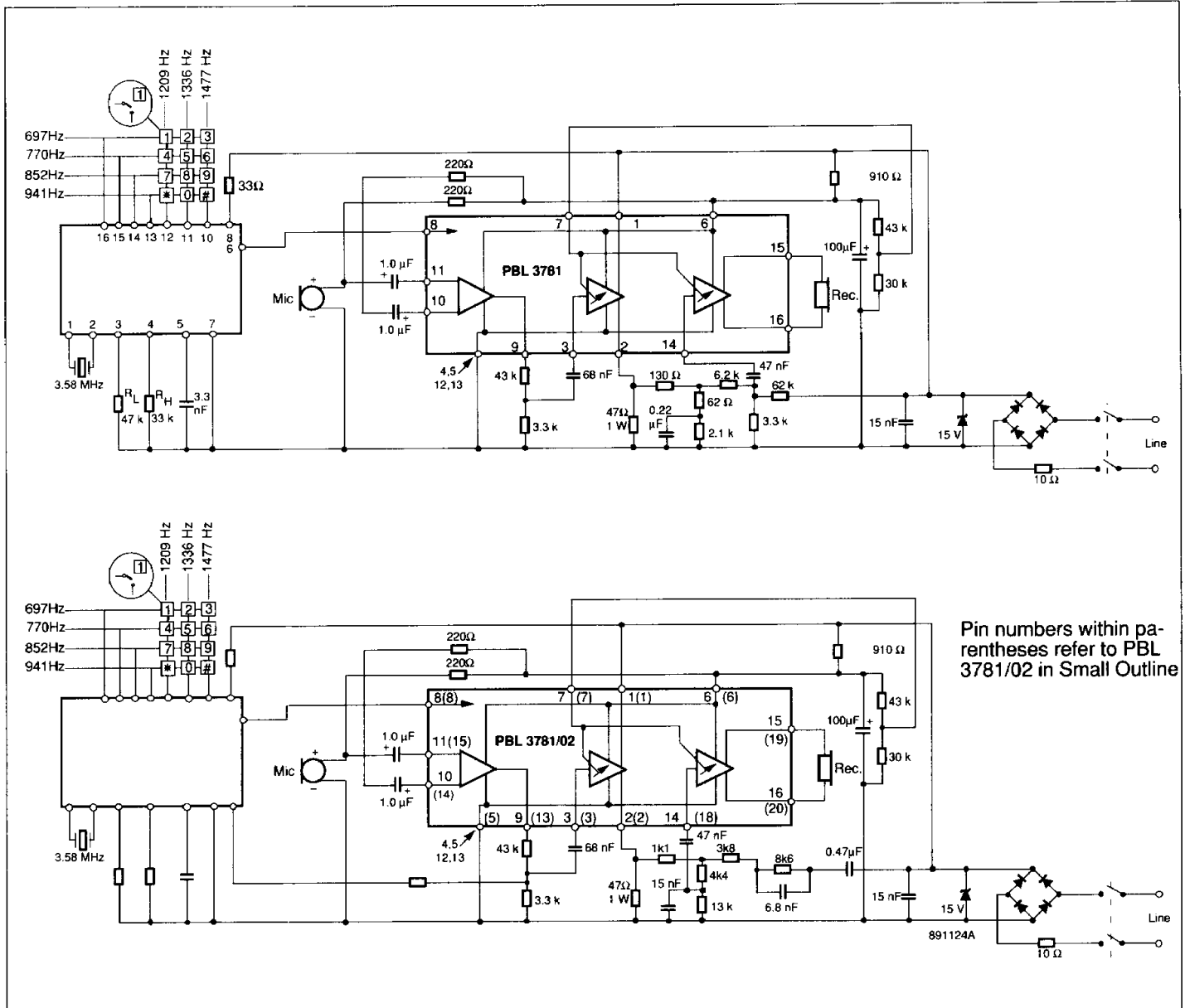

Figure 9. Typical tone-dialling telephone for 48V 2x200Ω battery feeding system.

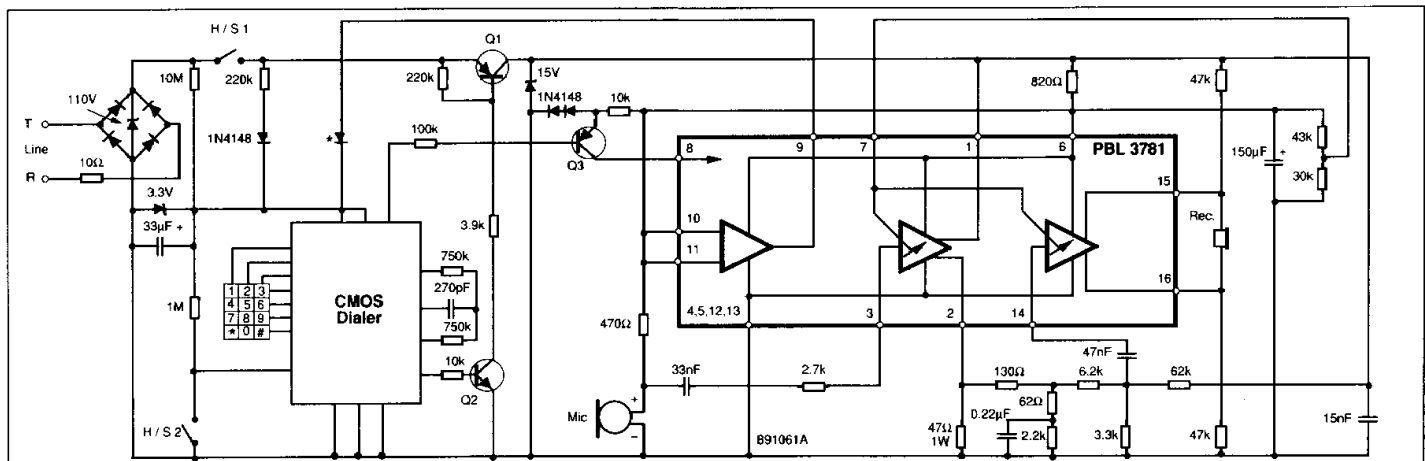

Figure 10. Typical pulse-dialling telephone for 48V 2x200Ω battery feeding system.



speech circuit, consuming a stand-by current of less than 250 uA. When a key closure is sensed, the speech circuit is muted, and a tone pair is generated directly on the line. Resistors RH and RL are used to set the output levels of the DTMF-generators. A reduced tone level is monitored in the receiver during dialling.

When using a CMOS DTMF-generator, a stabilized supply voltage may be derived from pin 6 of the PBL 3781, PBL 3781/02. The tones can be fed directly to the transit amplifier input as indicated in figure 7. The mute input requires a minimum of 100 uA.

**Pulse dialling telephone**

Figure 10 shows a 10 number memory telephone, using a minimum number of components.

The current generator output at pin 9 of the PBL 3781, PBL 3781/02 and pin 13 of the PBL 3781/02 SO is used to feed the pulse dialler during off-hook. During on-hook, a 10 Mohm resistor to

the telephone line supplies a small amount of current to retain the memory.

Since the line current passes through the speech network during dialling, the pulses will be monitored in the receiver. However, by adding two balancing resistors of 47 kohms at the receiver output terminals, this effect is minimized.

**Ordering Information**

Package	Temp. Range
Plastic DIP	-20 to +70°C
Plastic DIP	-20 to +70°C
Plastic S/O	-20 to +70°C

**Part No.**

- PBL 3781N
- PBL 3781/02N
- PBL 3781/02SO