

## Terminal Voltage 0V to +15V, 100 Taps

# X9312

## E<sup>2</sup>POT™ Nonvolatile Digital Potentiometer

### FEATURES

- **Compatible with X9C102/103/104/503**
- **Low Power CMOS**
  - Active Current, 3mA Max
  - Standby Current, 1mA Max
- **99 Resistive Elements**
  - Temperature Compensated
  - ±20% End to End Resistance Range
  - 0 to +15V Range
- **100 Wiper Tap Points**
  - Wiper Positioned via Three-Wire Interface
  - Similar to TTL Up/Down Counter
  - Wiper Position Stored in Nonvolatile Memory and Recalled on Power-Up
- **100 Year Wiper Position Data Retention**
- **X9312Z = 1KΩ**
- **X9312W = 10KΩ**
- **X9312U = 50KΩ**
- **X9312T = 100KΩ**

### DESCRIPTION

The Xicor X9312 is a solid state nonvolatile potentiometer and is ideal for digitally controlled resistance trimming.

The X9312 is a resistor array composed of 99 resistive elements. Between each element and at either end are tap points accessible to the wiper element. The position of the wiper element is controlled by the  $\overline{CS}$ ,  $U/\overline{D}$ , and  $\overline{INC}$  inputs. The position of the wiper can be stored in nonvolatile memory and then be recalled upon a subsequent power-up operation.

The resolution of the X9312 is equal to the maximum resistance value divided by 99. As an example, for the X9312U (50KΩ) each tap point represents 505Ω.

All Xicor nonvolatile memories are designed and tested for applications requiring extended endurance and data retention.

### FUNCTIONAL DIAGRAM

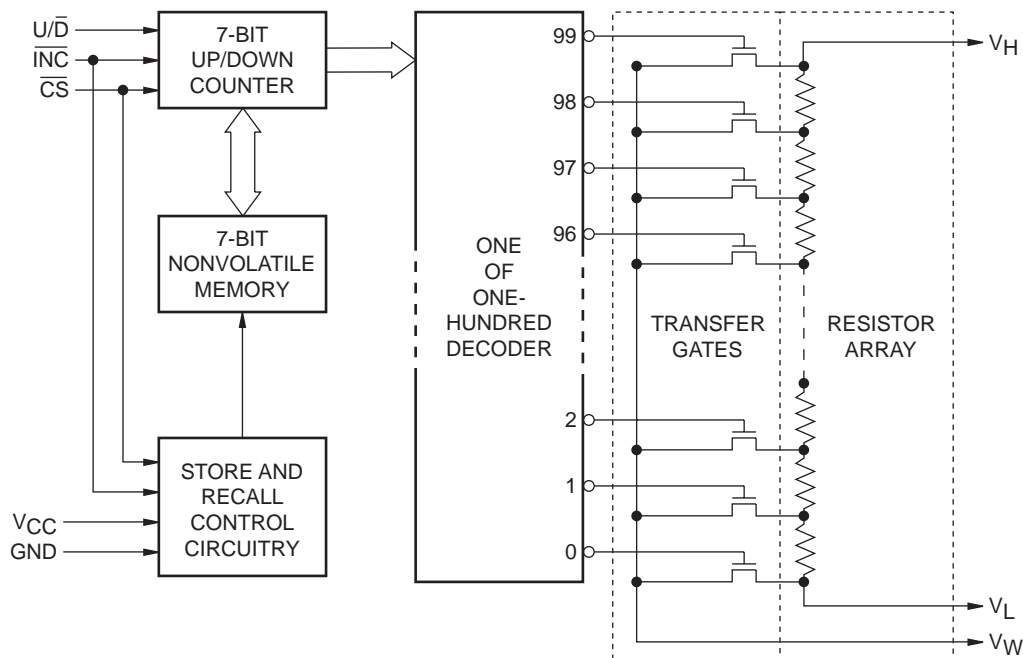

3865 FHD F01

E<sup>2</sup>POT™ is a trademark of Xicor, Inc.

©Xicor, Inc. 1994, 1995 Patents Pending  
 3865-2.4 12/1/95 T1/C0/D0 NS

# X9312

## PIN DESCRIPTIONS

### $V_H$ and $V_L$

The high ( $V_H$ ) and low ( $V_L$ ) terminals of the X9312 are equivalent to the fixed terminals of a mechanical potentiometer. The minimum voltage is 0V and the maximum is +15V. It should be noted that the terminology of  $V_L$  and  $V_H$  references the relative position of the terminal in relation to wiper movement direction selected by the  $U/\bar{D}$  input and not the voltage potential on the terminal.

### $V_W$

$V_W$  is the wiper terminal, equivalent to the movable terminal of a mechanical potentiometer. The position of the wiper within the array is determined by the control inputs. The wiper terminal series resistance is typically 40Ω.

### Up/Down ( $U/\bar{D}$ )

The  $U/\bar{D}$  input controls the direction of the wiper movement and whether the counter is incremented or decremented.

### Increment ( $\bar{INC}$ )

The  $\bar{INC}$  input is negative-edge triggered. Toggling  $\bar{INC}$  will move the wiper and either increment or decrement the counter in the direction indicated by the logic level on the  $U/\bar{D}$  input.

### Chip Select ( $\bar{CS}$ )

The device is selected when the  $\bar{CS}$  input is LOW. The current counter value is stored in nonvolatile memory when  $\bar{CS}$  is returned HIGH while the  $\bar{INC}$  input is also HIGH. After the store operation is complete the X9312 will be placed in the low power standby mode until the device is selected once again.

## PIN CONFIGURATION

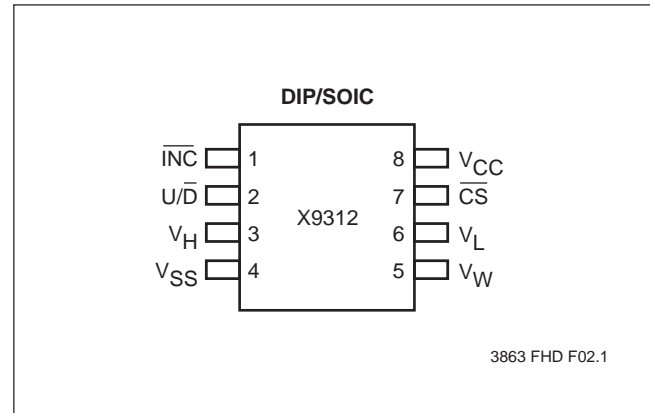

## PIN NAMES

Symbol	Description
$V_H$	High Terminal
$V_W$	Wiper Terminal
$V_L$	Low Terminal
$V_{SS}$	Ground
$V_{CC}$	Supply Voltage
$U/\bar{D}$	Up/Down Input
$\bar{INC}$	Increment Input
$\bar{CS}$	Chip Select Input

3865 PGM T01

# X9312

## DEVICE OPERATION

There are three sections of the X9312: the input control, counter and decode section; the nonvolatile memory; and the resistor array. The input control section operates just like an up/down counter. The output of this counter is decoded to turn on a single electronic switch connecting a point on the resistor array to the wiper output. Under the proper conditions the contents of the counter can be stored in nonvolatile memory and retained for future use. The resistor array is comprised of 99 individual resistors connected in series. At either end of the array and between each resistor is an electronic switch that transfers the potential at that point to the wiper.

The  $\overline{INC}$ ,  $U/\overline{D}$  and  $\overline{CS}$  inputs control the movement of the wiper along the resistor array. With  $\overline{CS}$  set LOW the X9312 is selected and enabled to respond to the  $U/\overline{D}$  and  $\overline{INC}$  inputs. HIGH to LOW transitions on  $\overline{INC}$  will increment or decrement (depending on the state of the  $U/\overline{D}$  input) a seven bit counter. The output of this counter is decoded to select one of one-hundred wiper positions along the resistive array.

The wiper, when at either fixed terminal, acts like its mechanical equivalent and does not move beyond the last position. That is, the counter does not wrap around when clocked to either extreme.

The value of the counter is stored in nonvolatile memory whenever  $\overline{CS}$  transitions HIGH while the  $\overline{INC}$  input is also HIGH.

When the X9312 is powered-down, the last counter position stored will be maintained in the nonvolatile memory. When power is restored, the contents of the memory are recalled and the counter is reset to the value last stored.

## Operation Notes

The system may select the X9312, move the wiper and deselect the device without having to store the latest wiper position in nonvolatile memory. The wiper movement is performed as described above; once the new position is reached, the system would keep  $\overline{INC}$  LOW while taking  $\overline{CS}$  HIGH. The new wiper position would be maintained until changed by the system or until a power-up/down cycle recalled the previously stored data.

This would allow the system to always power-up to a preset value stored in nonvolatile memory; then during system operation minor adjustments could be made. The adjustments might be based on user preference, system parameter changes due to temperature drift, etc...

The state of  $U/\overline{D}$  may be changed while  $\overline{CS}$  remains LOW. This allows the host system to enable the X9312 and then move the wiper up and down until the proper trim is attained.





### $T_{IW}/R_{TOTAL}$

The electronic switches on the X9312 operate in a "make before break" mode when the wiper changes tap positions. If the wiper is moved several positions multiple taps are connected to the wiper for  $t_{IW}$  ( $\overline{INC}$  to  $V_W$  change). The  $R_{TOTAL}$  value for the device can temporarily be reduced by a significant amount if the wiper is moved several positions.

### $R_{TOTAL}$ with $V_{CC}$ Removed

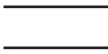
The end to end resistance of the array will fluctuate once  $V_{CC}$  is removed.

## SYMBOL TABLE

WAVEFORM	INPUTS	OUTPUTS
	Must be steady	Will be steady
	May change from LOW to HIGH	Will change from LOW to HIGH
	May change from HIGH to LOW	Will change from HIGH to LOW
	Don't Care: Changes Allowed	Changing: State Not Known
	N/A	Center Line is High Impedance

# X9312

## ABSOLUTE MAXIMUM RATINGS\*

Temperature under Bias .....  $-65^{\circ}\text{C}$  to  $+135^{\circ}\text{C}$   
 Storage Temperature .....  $-65^{\circ}\text{C}$  to  $+150^{\circ}\text{C}$   
 Voltage on  $\overline{\text{CS}}$ ,  $\overline{\text{INC}}$ ,  $\text{U}/\overline{\text{D}}$  and  $\text{V}_{\text{CC}}$   
 with Respect to  $\text{V}_{\text{SS}}$  .....  $-1\text{V}$  to  $+7\text{V}$   
 Voltage on  $\text{V}_{\text{H}}$  and  $\text{V}_{\text{L}}$  Referenced to  $\text{V}_{\text{SS}}$   
 $\Delta\text{V} = |\text{V}_{\text{H}} - \text{V}_{\text{L}}|$   
 X9312Z, X9312W, X9312U, and X9312T .....  $15\text{V}$   
 Lead Temperature (Soldering 10 seconds) .....  $300^{\circ}\text{C}$   
 Wiper Current .....  $\pm 1\text{mA}$

## ANALOG CHARACTERISTICS

### Electrical Characteristics

End-to-End Resistance Tolerance .....  $\pm 20\%$   
 Power Rating at  $25^{\circ}\text{C}$   
 X9312Z, .....  $225\text{mW}$   
 X9312W, X9312U, and X9312T .....  $25\text{mW}$   
 Wiper Current .....  $\pm 1\text{mA}$  Max.  
 Typical Wiper Resistance .....  $40\Omega$  at  $1\text{mA}$   
 Typical Noise .....  $< -120\text{dB}/\sqrt{\text{Hz}}$  Ref:  $1\text{V}$

### Resolution

Resistance .....  $1\%$

### Linearity

Absolute Linearity<sup>(1)</sup> .....  $\pm 1.0 \text{ MI}$ <sup>(2)</sup>  
 Relative Linearity<sup>(3)</sup> .....  $\pm 0.2 \text{ MI}$ <sup>(2)</sup>

### Test Circuit #1

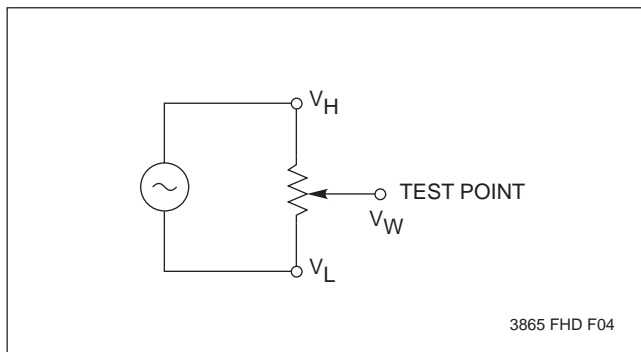

## \*COMMENT

Stresses above those listed under “Absolute Maximum Ratings” may cause permanent damage to the device. This is a stress rating only and the functional operation of the device at these or any other conditions above those listed in the operational sections of this specification is not implied. Exposure to absolute maximum rating conditions for extended periods may affect device reliability.

### Temperature Coefficient

( $-40^{\circ}\text{C}$  to  $+85^{\circ}\text{C}$ )  
 X9312W, X9312U and  
 X9312T .....  $+300 \text{ ppm}/^{\circ}\text{C}$  Typical  
 Ratiometric Temperature Coefficient .....  $\pm 20 \text{ ppm}$

### Wiper Adjustability

Unlimited Wiper Adjustment (Non-Store operation)  
 Wiper Position Store Operations .....  $10,000$   
 Data Changes

### Physical Characteristics

#### Marking Includes

Manufacturer's Trademark  
 Resistance Value or Code  
 Date Code

### Test Circuit #2

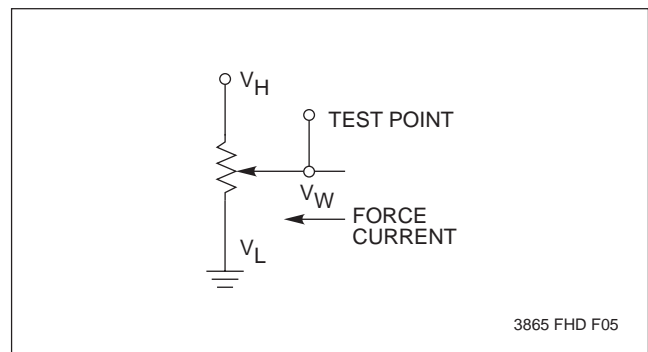

- Notes:** (1) Absolute Linearity is utilized to determine actual wiper voltage versus expected voltage  
 $= (\text{V}_{\text{W}(n)}(\text{actual}) - \text{V}_{\text{W}(n)}(\text{expected})) = \pm 1 \text{ MI}$  Maximum.  
 (2)  $1 \text{ MI} = \text{Minimum Increment} = \text{R}_{\text{TOT}}/99$ .  
 (3) Relative Linearity is a measure of the error in step size between taps  $= \text{V}_{\text{W}(n+1)} - [\text{V}_{\text{W}(n)} + \text{MI}] = +0.2 \text{ MI}$ .

# X9312

## RECOMMENDED OPERATING CONDITIONS

Temperature	Min.	Max.
Commercial	0°C	+70°C
Industrial	-40°C	+85°C
Military	-55°C	+125°C

3865 PGM T03.1

Supply Voltage	Limits
X9312	5V ±10%

3865 PGM T04.1

## D.C. OPERATING CHARACTERISTICS (Over recommended operating conditions unless otherwise specified.)

Symbol	Parameter	Limits			Units	Test Conditions
		Min.	Typ.(4)	Max.		
I <sub>CC</sub>	V <sub>CC</sub> Active Current		1	3	mA	$\overline{CS} = V_{IL}$ , $U/\overline{D} = V_{IL}$ or $V_{IH}$ and $\overline{INC} = 0.4V/2.4V$ @ max. $t_{CYC}$
I <sub>SB</sub>	Standby Supply Current		500	1000	μA	$\overline{CS} = V_{CC} - 0.3V$ , $U/\overline{D}$ and $\overline{INC} = V_{SS}$ or $V_{CC} - 0.3V$
I <sub>LI</sub>	$\overline{CS}$ , $\overline{INC}$ , $U/\overline{D}$ Input Leakage Current			±10	μA	$V_{IN} = V_{SS}$ to $V_{CC}$
V <sub>IH</sub>	$\overline{CS}$ , $\overline{INC}$ , $U/\overline{D}$ Input HIGH Voltage	2		$V_{CC} + 1$	V	
V <sub>IL</sub>	$\overline{CS}$ , $\overline{INC}$ , $U/\overline{D}$ Input LOW Voltage	-1		0.8	V	
R <sub>W</sub>	Wiper Resistance		40	100	Ω	Max. Wiper Current ±1mA
V <sub>VH</sub>	VH Terminal Voltage	0		15	V	
V <sub>VL</sub>	VL Terminal Voltage	0		15	V	
C <sub>IN</sub> (5)	$\overline{CS}$ , $\overline{INC}$ , $U/\overline{D}$ Input Capacitance			10	pF	$V_{CC} = 5V$ , $V_{IN} = V_{SS}$ , $T_A = 25^\circ C$ , $f = 1MHz$

3865 PGM T05.3

## STANDARD PARTS

Part Number	Maximum Resistance	Wiper Increments	Minimum Resistance
X9312Z	1KΩ	10.1Ω	40Ω
X9312W	10KΩ	101Ω	40Ω
X9312U	50KΩ	505Ω	40Ω
X9312T	100KΩ	1010Ω	40Ω

- Notes:** (4) Typical values are for  $T_A = 25^\circ C$  and nominal supply voltage.  
 (5) This parameter is periodically sampled and not 100% tested.

3865 PGM T08.1

# X9312

## A.C. CONDITIONS OF TEST

Input Pulse Levels	0V to 3V
Input Rise and Fall Times	10ns
Input Reference Levels	1.5V

3865 PGM T05.1

## MODE SELECTION

$\overline{CS}$	$\overline{INC}$	$U/\overline{D}$	Mode
L	$\lambda$	H	Wiper Up
L	$\lambda$	L	Wiper Down
f	H	X	Store Wiper Position
H	X	X	Standby
f	L	X	No Store, Return to Standby

3865 PGM T06

## A.C. OPERATING CHARACTERISTICS (Over recommended operating conditions unless otherwise specified)

Symbol	Parameter	Limits			Units
		Min.	Typ.(6)	Max.	
$t_{CI}$	$\overline{CS}$ to $\overline{INC}$ Setup	100			ns
$t_{ID}$	$\overline{INC}$ HIGH to $U/\overline{D}$ Change	100			ns
$t_{DI}$	$U/\overline{D}$ to $\overline{INC}$ Setup	1			$\mu$ s
$t_{IL}$	$\overline{INC}$ LOW Period	1			$\mu$ s
$t_{IH}$	$\overline{INC}$ HIGH Period	1			$\mu$ s
$t_{IC}$	$\overline{INC}$ Inactive to $\overline{CS}$ Inactive	1			$\mu$ s
$t_{CPH}$	$\overline{CS}$ Deselect Time	20			ms
$t_{IW}$	$\overline{INC}$ to $V_W$ Change		100	500	$\mu$ s
$t_{CYC}$	$\overline{INC}$ Cycle Time	4			$\mu$ s
$t_R, t_F^{(7)}$	$\overline{INC}$ Input Rise and Fall Time			500	$\mu$ s
$t_{PU}^{(7)}$	Power up to Wiper Stable			500	$\mu$ s
$t_R V_{CC}^{(7)}$	$V_{CC}$ Power-up Rate	0.2		50	mV/ $\mu$ s

3865 PGM T07.4

## A.C. Timing

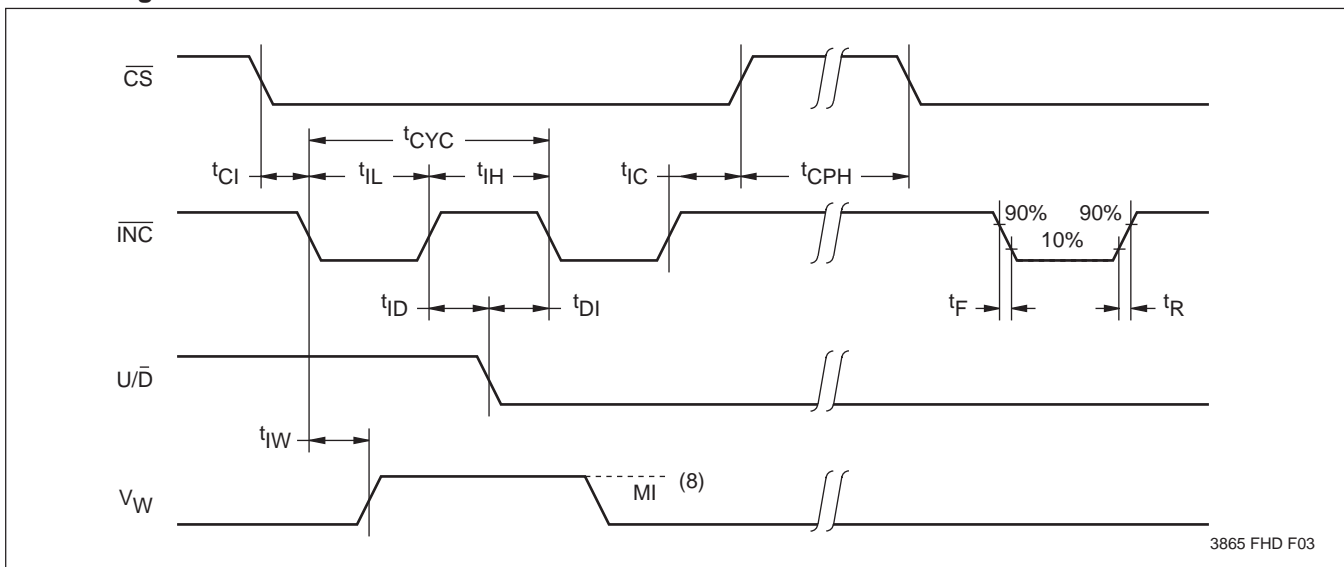

3865 FHD F03

- Notes:** (6) Typical values are for  $T_A = 25^\circ\text{C}$  and nominal supply voltage.  
 (7) This parameter is periodically sampled and not 100% tested.  
 (8) MI in the A.C. timing diagram refers to the minimum incremental change in the  $V_W$  output due to a change in the wiper position.

PACKAGING INFORMATION

8-LEAD PLASTIC DUAL IN-LINE PACKAGE TYPE P

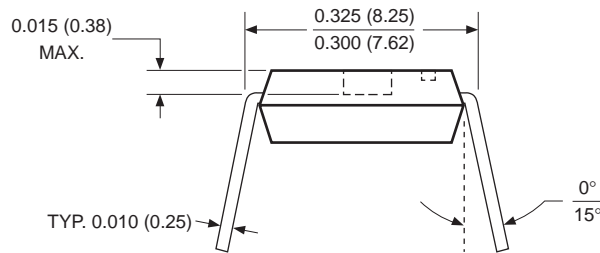
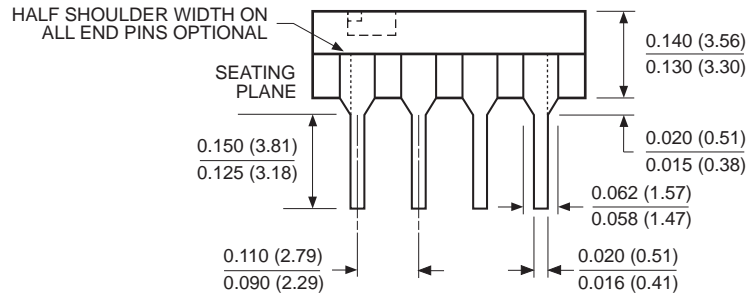
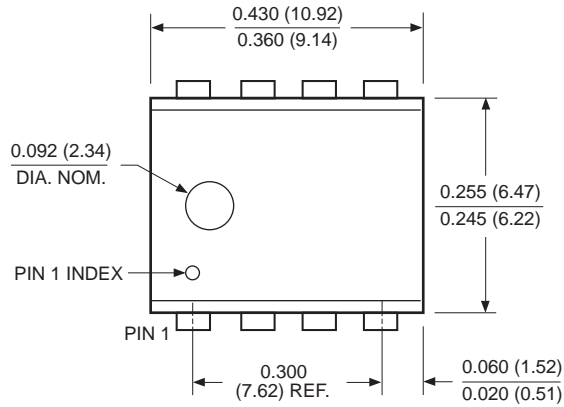

NOTE: ALL DIMENSIONS IN INCHES (IN PARENTHESES IN MILLIMETERS)

3926 FHD F01

PACKAGING INFORMATION

8-LEAD PLASTIC SMALL OUTLINE GULL WING PACKAGE TYPE S

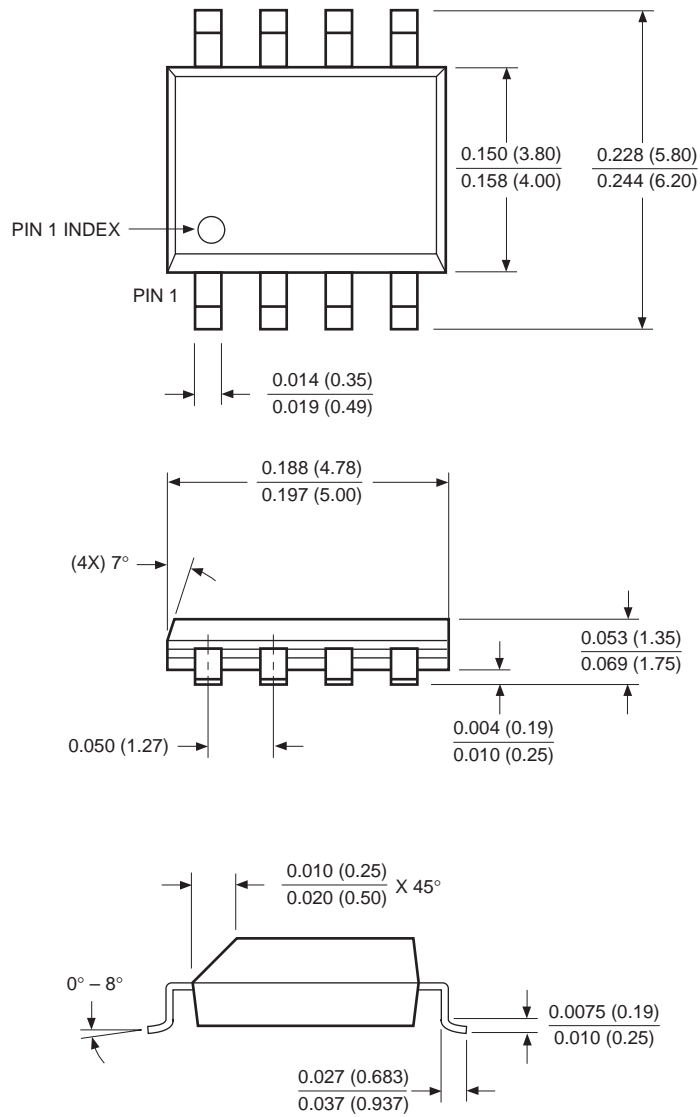

NOTE: ALL DIMENSIONS IN INCHES (IN PARENTHESIS IN MILLIMETERS)

3926 FHD F22



# X9312

---

## ORDERING INFORMATION

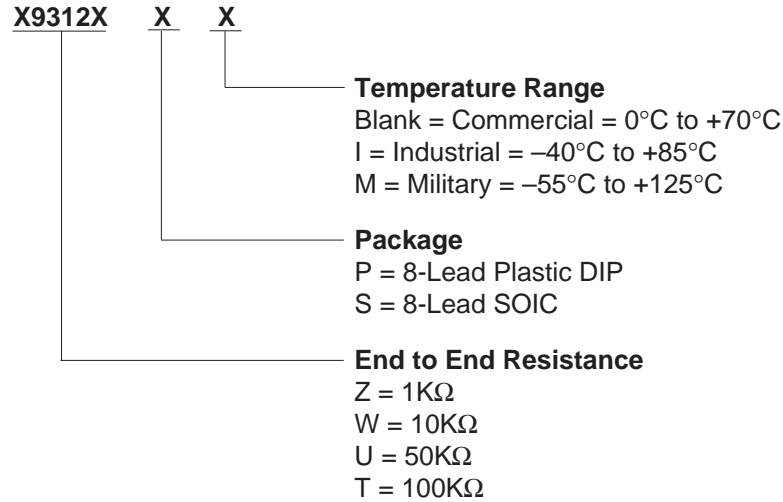

---

### LIMITED WARRANTY

Devices sold by Xicor, Inc. are covered by the warranty and patent indemnification provisions appearing in its Terms of Sale only. Xicor, Inc. makes no warranty, express, statutory, implied, or by description regarding the information set forth herein or regarding the freedom of the described devices from patent infringement. Xicor, Inc. makes no warranty of merchantability or fitness for any purpose. Xicor, Inc. reserves the right to discontinue production and change specifications and prices at any time and without notice.

Xicor, Inc. assumes no responsibility for the use of any circuitry other than circuitry embodied in a Xicor, Inc. product. No other circuits, patents, licenses are implied.

### U.S. PATENTS

Xicor products are covered by one or more of the following U.S. Patents: 4,263,664; 4,274,012; 4,300,212; 4,314,265; 4,326,134; 4,393,481; 4,404,475; 4,450,402; 4,486,769; 4,488,060; 4,520,461; 4,533,846; 4,599,706; 4,617,652; 4,668,932; 4,752,912; 4,829, 482; 4,874, 967; 4,883, 976. Foreign patents and additional patents pending.

### LIFE RELATED POLICY

In situations where semiconductor component failure may endanger life, system designers using this product should design the system with appropriate error detection and correction, redundancy and back-up features to prevent such an occurrence.

Xicor's products are not authorized for use in critical components in life support devices or systems.

1. Life support devices or systems are devices or systems which, (a) are intended for surgical implant into the body, or (b) support or sustain life, and whose failure to perform, when properly used in accordance with instructions for use provided in the labeling, can be reasonably expected to result in a significant injury to the user.
2. A critical component is any component of a life support device or system whose failure to perform can be reasonably expected to cause the failure of the life support device or system, or to affect its safety or effectiveness.