

FG system speed servo controller

BA6301 / BA6301F / BA6321

The BA6301, BA6301F, and BA6321 are single package servo control ICs suitable for controlling the speed of VCR motors. The ICs contain an F / V conversion section for speed control, a hysteresis amplifier section for waveform shaping, and an MIX amplifier section for speed / phase control output. They are compatible with either phase lagging or phase leading servo by setting the MIX system according to the phase servo control and MDA. They provide stable and efficient operation with either 5, 9, or 12V supply voltage. Motor speed can be controlled precisely at different levels with an FG program counter.

●Applications

Speed control of capstan motors, drum head motors, reel motors, cassette players, and record players

●Features

- | | |
|---|---|
| <ul style="list-style-type: none"> 1) Motor speed can be controlled by an FG program counter. 2) S / H type F / V converter allows servo control of various FG frequencies (BA6301 / F or BA6321 is used for f_c greater or less than 600Hz, respectively) | <ul style="list-style-type: none"> 3) Quick and precise motor starting. 4) Low current dissipation. 5) Wide range of operating voltage. 6) Limited number of external components. |
|---|---|

●Block diagram

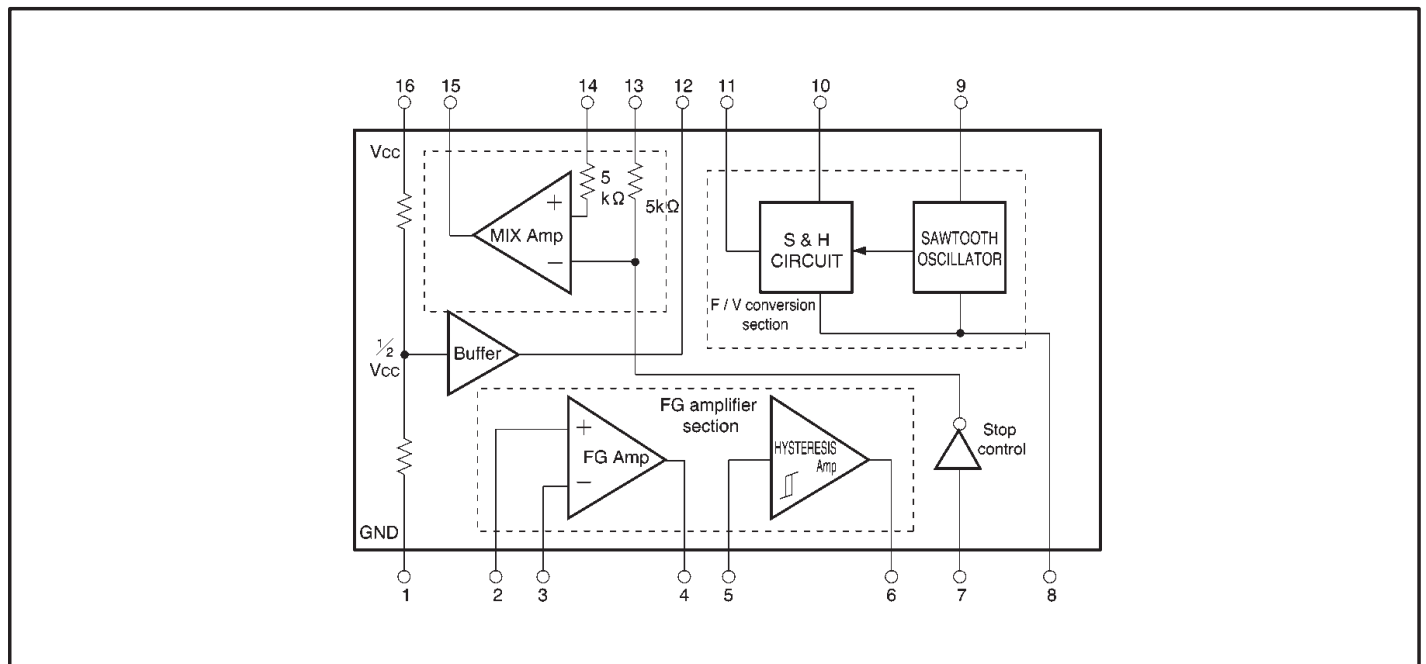

● Internal circuit configuration

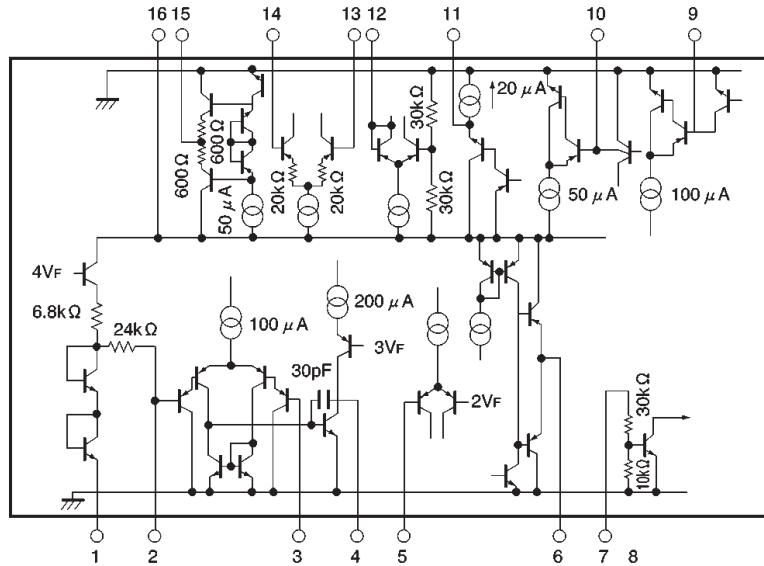

● Absolute maximum ratings (Ta = 25°C)

Parameter	Symbol	Limits	Unit
Power supply voltage	V _{CC}	15	V
Power dissipation	P _d	450*	mW
Operating temperature	T _{opr}	-20~+60	°C
Storage temperature	T _{stg}	-55~+125	°C

* Reduced by 4.5 mW for each increase in Ta of 1°C over 25°C.

● Electrical characteristics (unless otherwise noted, Ta = 25°C, V_{CC}=9V)

Parameter		Symbol	Min.	Typ.	Max.	Unit	Conditions
Operating voltage		V _{CC}	4.5	—	13.0	V	—
Quiescent current		I _o	1.1	2.2	4.4	mA	—
FG amplifier section	Open loop voltage gain	G _{vo1}	65	73	—	dB	R _{FG} =100kΩ
	Output level	V _{FGO}	2.0	2.6	—	V _{P-P}	—
	Mean-hysteresis voltage	V _{hyM}	-130	-60	0	mV	Electric potential difference from pin3
	Hysteresis voltage width	V _{hyW}	30	70	110	mV	—
	Hysteresis amplifier output level	V _{hyO}	6.0	7.0	—	V _{P-P}	R _L =20kΩ
F / V converter section	Output temperature coefficient	ΔV _{FVT}	—	-2	-5	mV / °C	V _{FVO} =4.5V
	Output drift	ΔV _{FVD}	—	-0.05	-0.1	% / °C	V _{FVO} =4.5V
	Output level	V _{FVO}	—	7.5	—	V _{P-P}	R _L =∞
MIX amplifier section	Open loop voltage gain	G _{vo2}	50	60	—	dB	—
	Output level	V _{MIXO}	6.0	7.0	—	V _{P-P}	R _L =20kΩ
Mean-bias voltage		V _{Bias}	4.3	4.5	4.8	V	—
Forced stop control	Forced stop threshold	V _{IN TH}	1.0	2.0	3.0	V	V _{MIXO} <1.0V
	Input resistance	R _{IN}	20	30	40	kΩ	—

●Application example

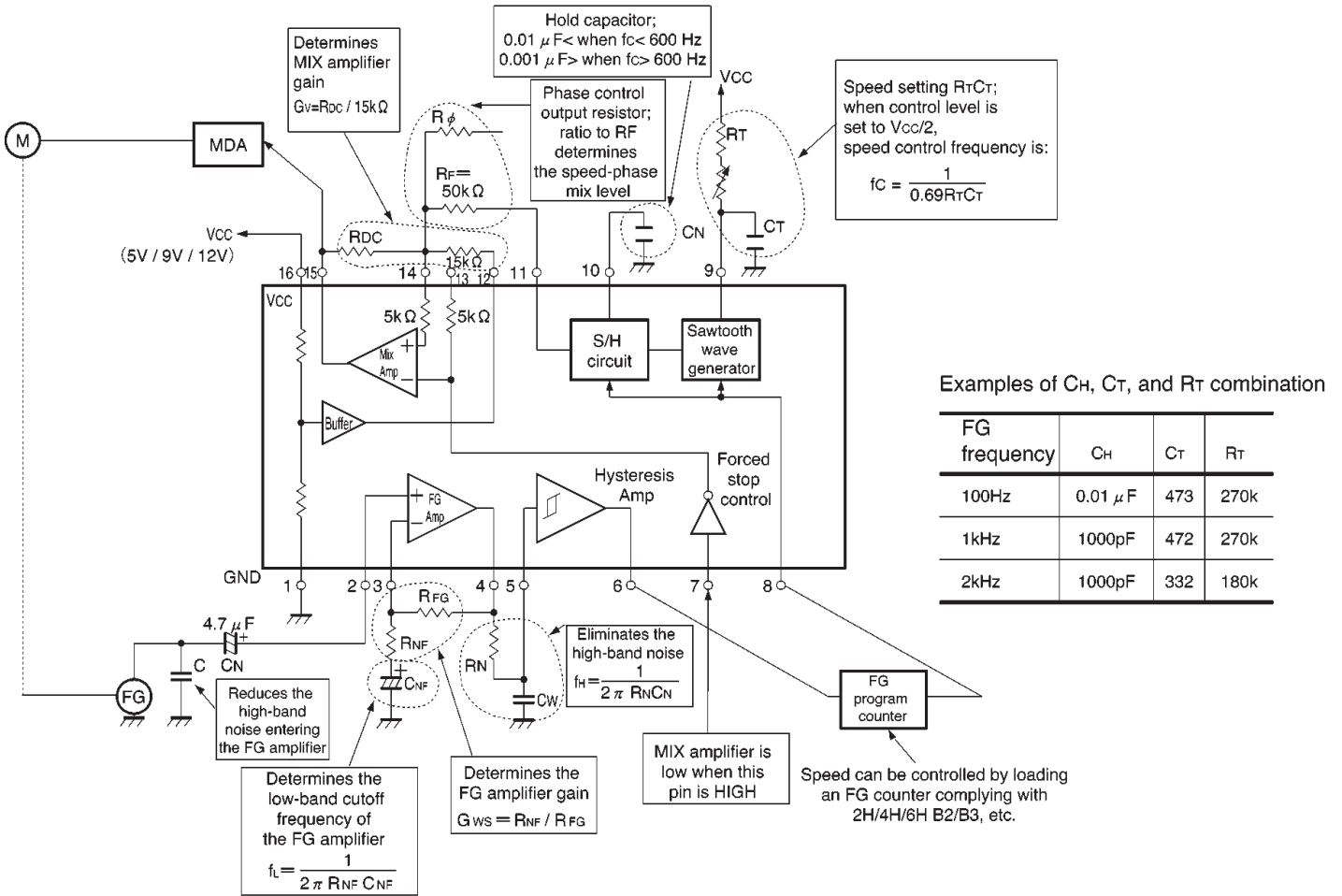

●Electrical characteristic curves

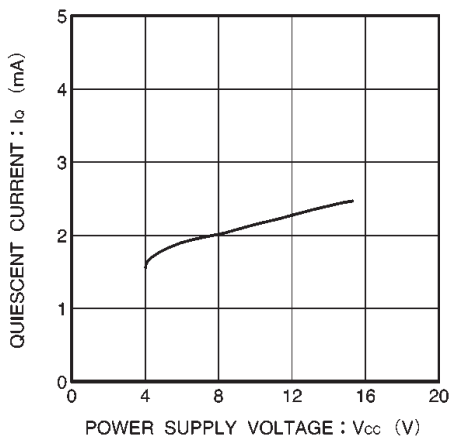

Fig.1 Quiescent current vs. power supply current

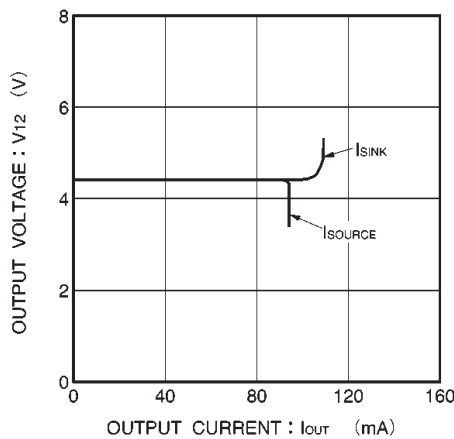

Fig.2 Pin-12 output voltage vs. output current

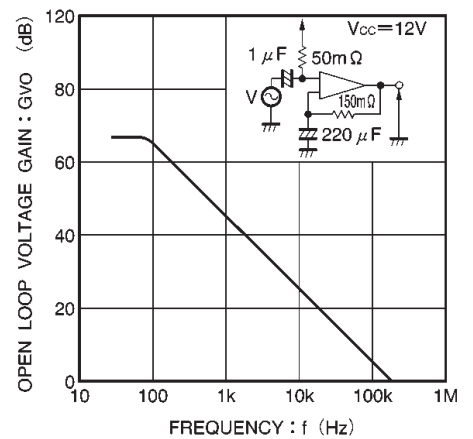

Fig.3 MIX amplifier open loop voltage gain vs. frequency

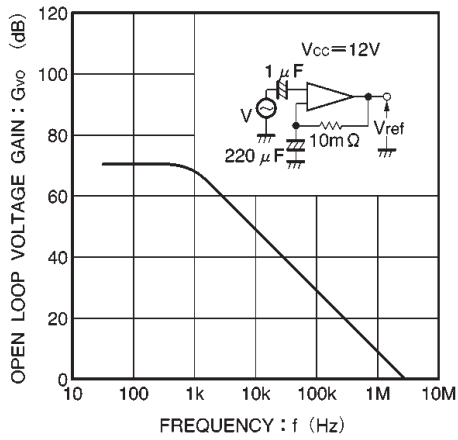

Fig.4 FG amplifier open loop voltage gain vs. frequency

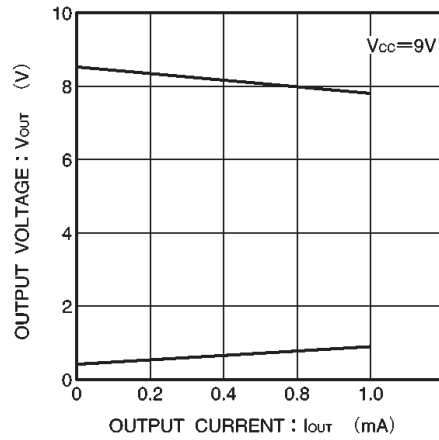

Fig.5 Hysteresis amplifier output voltage vs. output current

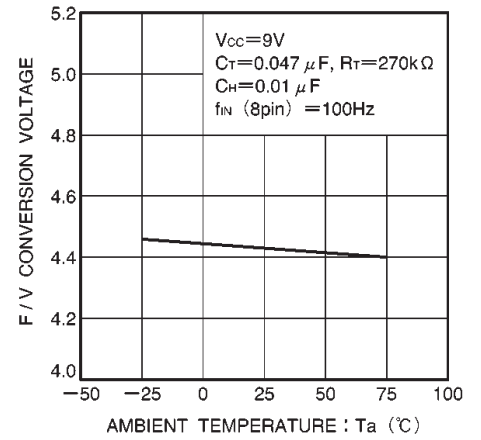
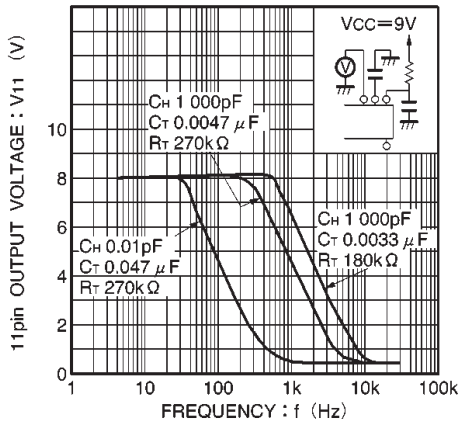

Fig.6 F / V conversion voltage temperature characteristic



Note: current sink capacity of pin 11 is about 20 μA

Fig.7 F / V conversion characteristics (no load : pin11)

●External dimensions (Units: mm)

