

February 1999

**OBSOLETE PRODUCT**  
**NO RECOMMENDED REPLACEMENT**  
Call Central Applications 1-800-442-7747  
or email: centapp@harris.com

## CMOS 4 x 4 x 2 Crosspoint Switch with Control Memory

### Features

- Low ON Resistance . . . . . 75Ω (Typ) at V<sub>DD</sub> = 12V
- “Built - In” Latched Inputs
- Large Analog Signal Capability . . . . . ±V<sub>DD</sub>/2
- Switch Bandwidth . . . . . 10MHz
- Matched Switch Characteristics  
ΔR<sub>ON</sub> = 8Ω (Typ) at V<sub>DD</sub> = 12V
- High Linearity - 0.25% Distortion (Typ) at f = 1kHz,  
V<sub>IN</sub> = 5V<sub>P-P</sub>, V<sub>DD</sub> - V<sub>SS</sub> = 10V, and R<sub>L</sub> = 1kΩ
- Standard CMOS Noise Immunity

### Applications

- Telephone Systems
- PBX
- Studio Audio Switching
- Multisystem Bus Interconnect

### Ordering Information

PART NUMBER	TEMP. RANGE (°C)	PACKAGE	PKG. NO.
CD22101E	-40 to 85	24 Ld PDIP	E24.6
CD22101F	-55 to 125	24 Ld CERDIP	F24.6
CD22102E	-40 to 85	24 Ld PDIP	E24.6

### Description

CD22101 and CD22102 crosspoint switches consist of 4 x 4 x 2 arrays of crosspoints (transmission gates) with a 4-line to 16-line decoder and 16 latch circuits. Any one of the sixteen crosspoint pairs can be selected by applying the appropriate four-line address, corresponding crosspoints in each array are turned on and off simultaneously. Any number of crosspoints can be turned on simultaneously.

In the CD22101, the selected crosspoint pair can be turned on or off by applying a logic ONE or ZERO, respectively, to the data input, and applying a ONE to the strobe input. When the device is “powered up”, the states of the 16 switches are indeterminate. Therefore, all switches must be turned off by putting the strobe high, data-in low, and then addressing all switches in succession.

The selected pair of crosspoints in the CD22102 is turned on by applying a logic ONE to the K<sub>A</sub> (set) input while a logic ZERO is on the K<sub>B</sub> input, and turned off by applying a logic ONE to the K<sub>B</sub> (reset) input while a logic ZERO is on the K<sub>A</sub> input. In this respect, the control latches of the CD22102 are similar to SET/RESET flip-flops. They differ, however, in that the simultaneous application of ONes to the K<sub>A</sub> and K<sub>B</sub> inputs turns off (resets) all crosspoints. All crosspoints in both devices must be turned off as V<sub>DD</sub> is applied.

### Pinouts

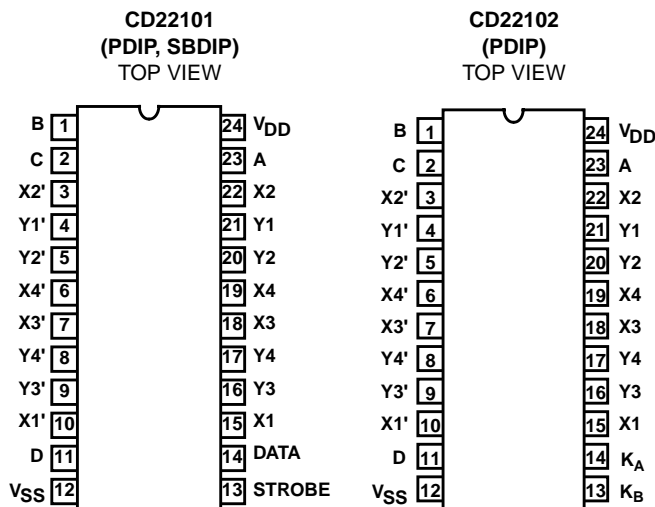

### Functional Diagram

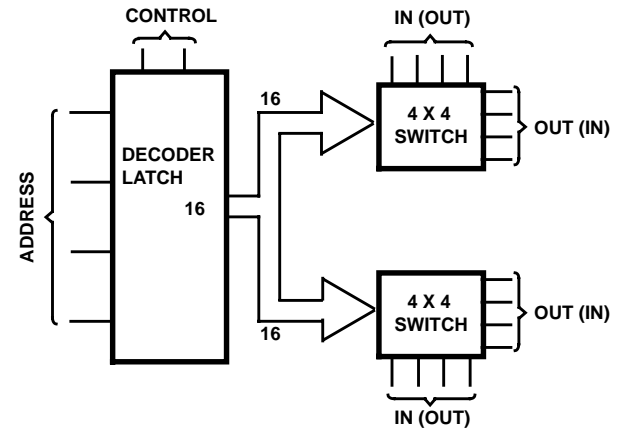

# CD22101, CD22102

## Absolute Maximum Ratings

Supply Voltage ( $V_{DD}$ ) (Referenced to  $V_{SS}$  Terminal) . . . . -0.5 to 20V  
 Input Voltage (All Inputs) . . . . . -0.5 to  $V_{DD} + 0.5V$   
 Supply Voltage Range  
 For  $T_A$  = Full Package Temperature Range . . . . . 3V to 18V  
 Input Current (Any One Input) (Note 1) . . . . .  $\pm 10mA$   
 Power Dissipation  
 For  $T_A$  = -40°C to 60°C (Package Type E) . . . . . 500mW  
 For  $T_A$  = 60°C to 85°C  
 Package Type E) . . . . . Derate Linearly 12mW/°C to 200mW  
 For  $T_A$  = -55°C to 100°C (Package Type D, F) . . . . . 500mW  
 For  $T_A$  = 100°C to 125°C  
 (Package Type D, F) . . . . . Derate Linearly 12mW/°C to 200mW  
 Device Dissipation per Output Transistor  
 For  $T_A$  = Full Package Temperature Range (All Types) . . . . . 100mW

## Thermal Information

Maximum Junction Temperature . . . . . 175°C  
 Maximum Junction Temperature (Plastic Package) . . . . . 150°C  
 Maximum Storage Temperature Range . . . . .  $-65^\circ C \leq T_A \leq 150^\circ C$   
 Maximum Lead Temperature (Soldering 10s) . . . . . 300°C

## Operating Conditions

Temperature Range  
 Package Type D, F . . . . .  $-55^\circ C \leq T_A \leq 125^\circ C$   
 Package Type E . . . . .  $-40^\circ C \leq T_A \leq 85^\circ C$

*CAUTION: Stresses above those listed in "Absolute Maximum Ratings" may cause permanent damage to the device. This is a stress only rating and operation of the device at these or any other conditions above those indicated in the operational sections of this specification is not implied.*

## Electrical Specifications

Values at -55°C, 25°C, 125°C Apply to D, F, H Packages  
 Values at -40°C, 25°C, 85°C Apply to E Package

PARAMETER	SYMBOL	TEST CONDITIONS		-55°C	-40°C	85°C	125°C	25°C			UNITS	
		FIGURE	$V_{DD}(V)$	MAX	MAX	MAX	MAX	MIN	TYP	MAX		
<b>STATIC CROSSPOINTS</b>												
Quiescent Device Current	$I_{DD} (Max)$		1	5	5	5	150	150	-	0.04	5	$\mu A$
			1	10	10	10	300	300	-	0.04	10	$\mu A$
			1	15	20	20	600	600	-	0.04	20	$\mu A$
			1	20	100	100	3000	3000	-	0.08	100	$\mu A$
On Resistance	$R_{ON} (Max)$	Any Switch $V_{IS} = 0$ to $V_{DD}$	14	5	475	500	725	800	-	225	600	$\Omega$
			15	10	135	145	205	230	-	85	180	$\Omega$
			-	12	100	110	155	175	-	75	135	$\Omega$
			16	15	70	75	110	125	-	65	95	$\Omega$
$\Delta_{ON}$ Resistance	$\Delta R_{ON}$	Between Any Two Switches	5		-	-	-	-	-	25	-	$\Omega$
			10		-	-	-	-	-	10	-	$\Omega$
			12		-	-	-	-	-	8	-	$\Omega$
			15		-	-	-	-	-	5	-	$\Omega$
OFF Leakage Current	$I_L (Max)$	All Switches OFF, $V_{IS} = 18V$	4	18	$\pm 1000$			-	$\pm 1$	$\pm 100$ (Note 2)	nA	
<b>STATIC CONTROLS</b>												
Input Low Voltage	$V_{IL} (Max)$	OFF Switch $I_L < 0.2\mu A$	5		1.5			-	-	1.5	V	
			10		3			-	-	3	V	
			15		4			-	-	4	V	
Input High Voltage	$V_{IH} (Min)$	ON Switch See $R_{ON}$ Characteristic	5		3.5			3.5	-	-	V	
			10		7			7	-	-	V	
			15		11			11	-	-	V	
Input Current	$I_{IN} (Max)$	Any Control $V_{IN} = 0, 18V$	2	18	$\pm 0.1$	$\pm 0.1$	$\pm 1$	$\pm 1$	-	$\pm 10^{-5}$	$\pm 0.1$	$\mu A$

**NOTES:**

- Maximum current through transmission gates (switches) = 25mA.
- Determined by minimum feasible leakage measurement for automatic testing.

## CD22101, CD22102

### Electrical Specifications $T_A = 25^\circ\text{C}$

PARAMETER	SYMBOL	TEST CONDITIONS				MIN	TYP	MAX	UNITS	
		FIGURE	$f_{IS}$ (kHz)	$R_L$ (k $\Omega$ )	$V_{IS}$ (V) (Note 3)					$V_{DD}$ (V)
<b>DYNAMIC CROSSPOINTS</b>										
Propagation Delay Time, (Switch ON) Signal Input to Output	$t_{PHL}, t_{PLH}$	5	-	-	5	5	-	30	60	ns
			-	10	10	10	-	15	30	ns
					15	15	-	10	20	ns
			$C_L = 50\text{pF}; t_R, t_F = 20\text{ns}$							
Frequency Response (Any Switch ON)	$f_{3dB}$	19	1	1	5	10	-	40	-	MHz
			Sine Wave Input, $20\log\frac{V_{OS}}{V_{IS}} = -3\text{dB}$							
Sine Wave Response (Distortion)	THD	-	1	1	2.5	5	-	1	-	%
			1	1	5	10	-	0.25	-	%
			1	1	7.5	15	-	0.15	-	%
Feedthrough (All Switches OFF)	$F_{DT}$	13	1.6	0.6	2 (Note 4)	10	-	-96	-	dB
			Sine Wave Input							
Frequency for Signal Crosstalk Attenuation of 40dB	$F_{CT}$	12	-	0.6	1 (Note 4)	10	-	2.5	-	MHz
			Sine Wave Input					0.1		
Capacitance:										
$X_N$ to Ground	$C_{IS}$			-	-	-	-	25	-	pF
$Y_N$ to Ground				-	-	-	-	60	-	pF
Feedthrough	$C_{IOS}$			-	-	-	-	0.6	-	pF
<b>DYNAMIC CONTROLS</b>										
Propagation Delay Time: High Impedance to High Level or Low Level  Strobe to Output, CD22101	$t_{PZH}, t_{PZL}$	6	$R_L = 1\text{k}\Omega, C_L = 50\text{pF}, t_R, t_F = 20\text{ns}$			5	-	500	1000	ns
						10	-	230	460	ns
						15	-	170	340	ns
Data-In to Output, CD22101	$t_{PZH}, t_{PZL}$	7	$R_L = 1\text{k}\Omega, C_L = 50\text{pF}, t_R, t_F = 20\text{ns}$			5	-	515	1000	ns
						10	-	220	440	ns
						15	-	170	340	ns
$K_A$ to Output, CD22102	$t_{PZH}, t_{PZL}$	-	$R_L = 1\text{k}\Omega, C_L = 50\text{pF}, t_R, t_F = 20\text{ns}$			5	-	500	1000	ns
						10	-	215	430	ns
						15	-	160	320	ns
Address to Output CD22101, CD22102	$t_{PZH}, t_{PZL}$	8	$R_L = 1\text{k}\Omega, C_L = 50\text{pF}, t_R, t_F = 20\text{ns}$			5	-	480	960	ns
						10	-	225	450	ns
						15	-	155	300	ns

**CD22101, CD22102**

**Electrical Specifications**     $T_A = 25^\circ\text{C}$  (Continued)

PARAMETER	SYMBOL	TEST CONDITIONS				MIN	TYP	MAX	UNITS
		FIGURE	$f_{IS}$ (kHz)	$R_L$ (k $\Omega$ )	$V_{IS}$ (V) (Note 3)				
Propagation Delay Time: High Level or Low Level to High Impedance Strobe to Output, CD22101	$t_{PHZ}, t_{PLZ}$	6	$R_L = 1\text{k}\Omega, C_L = 50\text{pF},$ $t_R, t_F = 20\text{ns}$	5	-	450	900	ns	
					10	-	200	400	ns
					15	-	135	270	ns
$K_B$ to Output, CD22102	$t_{PHZ}, t_{PLZ}$	-	$R_L = 1\text{k}\Omega, C_L = 50\text{pF},$ $t_R, t_F = 20\text{ns}$	5	-	450	900	ns	
					10	-	200	400	ns
					15	-	130	260	ns
Data-In to Output, CD22101	$t_{PHZ}, t_{PLZ}$	-	$R_L = 1\text{k}\Omega, C_L = 50\text{pF},$ $t_R, t_F = 20\text{ns}$	5	-	450	900	ns	
					10	-	165	330	ns
					15	-	110	220	ns
$K_A \bullet K_B$ to Output, CD22102	$t_{PHZ}, t_{PLZ}$	-	$R_L = 1\text{k}\Omega, C_L = 50\text{pF},$ $t_R, t_F = 20\text{ns}$	5	-	280	560	ns	
					10	-	130	260	ns
					15	-	90	180	ns
Address to Output CD22101, CD22102	$t_{PHZ}, t_{PLZ}$	8	$R_L = 1\text{k}\Omega, C_L = 50\text{pF},$ $t_R, t_F = 20\text{ns}$	5	-	425	850	ns	
					10	-	190	380	ns
					15	-	130	260	ns
Minimum Strobe Pulse Width, CD22101	$t_W$	6	$R_L = 1\text{k}\Omega, C_L = 50\text{pF},$ $t_R, t_F = 20\text{ns}$	5	-	260	500	ns	
					10	-	120	240	ns
					15	-	80	160	ns
Address to Strobe Setup or Hold Times, CD22101	$t_{SU}, t_H$	9	$R_L = 1\text{k}\Omega, C_L = 50\text{pF},$ $t_R, t_F = 20\text{ns}$	5	-	-160	0	ns	
					10	-	-70	0	ns
					15	-	-50	0	ns
Strobe to Data-In Hold Time, CD22101	$t_{HHL}, t_{HLH}$	10	$R_L = 1\text{k}\Omega, C_L = 50\text{pF},$ $t_R, t_F = 20\text{ns}$	5	-	200	400	ns	
					10	-	80	160	ns
					15	-	60	120	ns
Address to $K_A$ and $K_B$ Setup or Hold Times, CD22102	$t_{SU}, t_H$	-	$R_L = 1\text{k}\Omega, C_L = 50\text{pF},$ $t_R, t_F = 20\text{ns}$	5	-	-160	0	ns	
					10	-	-70	0	ns
					15	-	-50	0	ns
Minimum $K_A \bullet K_B$ Pulse Width, CD22102	$t_W$	-	$R_L = 1\text{k}\Omega, C_L = 50\text{pF},$ $t_R, t_F = 20\text{ns}$	5	-	375	750	ns	
					10	-	160	320	ns
					15	-	110	220	ns
Minimum $K_A$ Pulse Width, CD22102	$t_W$	-	$R_L = 1\text{k}\Omega, C_L = 50\text{pF},$ $t_R, t_F = 20\text{ns}$	5	-	425	850	ns	
					10	-	175	350	ns
					15	-	120	240	ns

# CD22101, CD22102

## Electrical Specifications $T_A = 25^\circ\text{C}$ (Continued)

PARAMETER	SYMBOL	FIGURE	TEST CONDITIONS				MIN	TYP	MAX	UNITS	
			$f_{IS}$ (kHz)	$R_L$ (k $\Omega$ )	$V_{IS}$ (V) (Note 3)	$V_{DD}$ (V)					
Minimum $K_B$ Pulse Width, CD22102	$t_W$	-	$R_L = 1\text{k}\Omega$ , $C_L = 50\text{pF}$ , $t_R, t_F = 20\text{ns}$				5	-	200	400	ns
							10	-	90	180	ns
							15	-	70	140	ns
Control Crosstalk, Data-In, Address or Strobe to Output		11	100	10		5	-	75	-	mV <sub>PEAK</sub>	
			Square Wave Input = 5V, $t_R, t_F = 20\text{ns}$ , $R_S = 1\text{k}\Omega$								
Input Capacitance	$C_{IN}$		Any Control Input			-	-	5	7.5	pF	

**NOTES:**

3. Peak-to-peak voltage symmetrical about  $\frac{V_{DD}}{2}$ , unless otherwise specified.
4. RMS.

## Functional Block Diagram

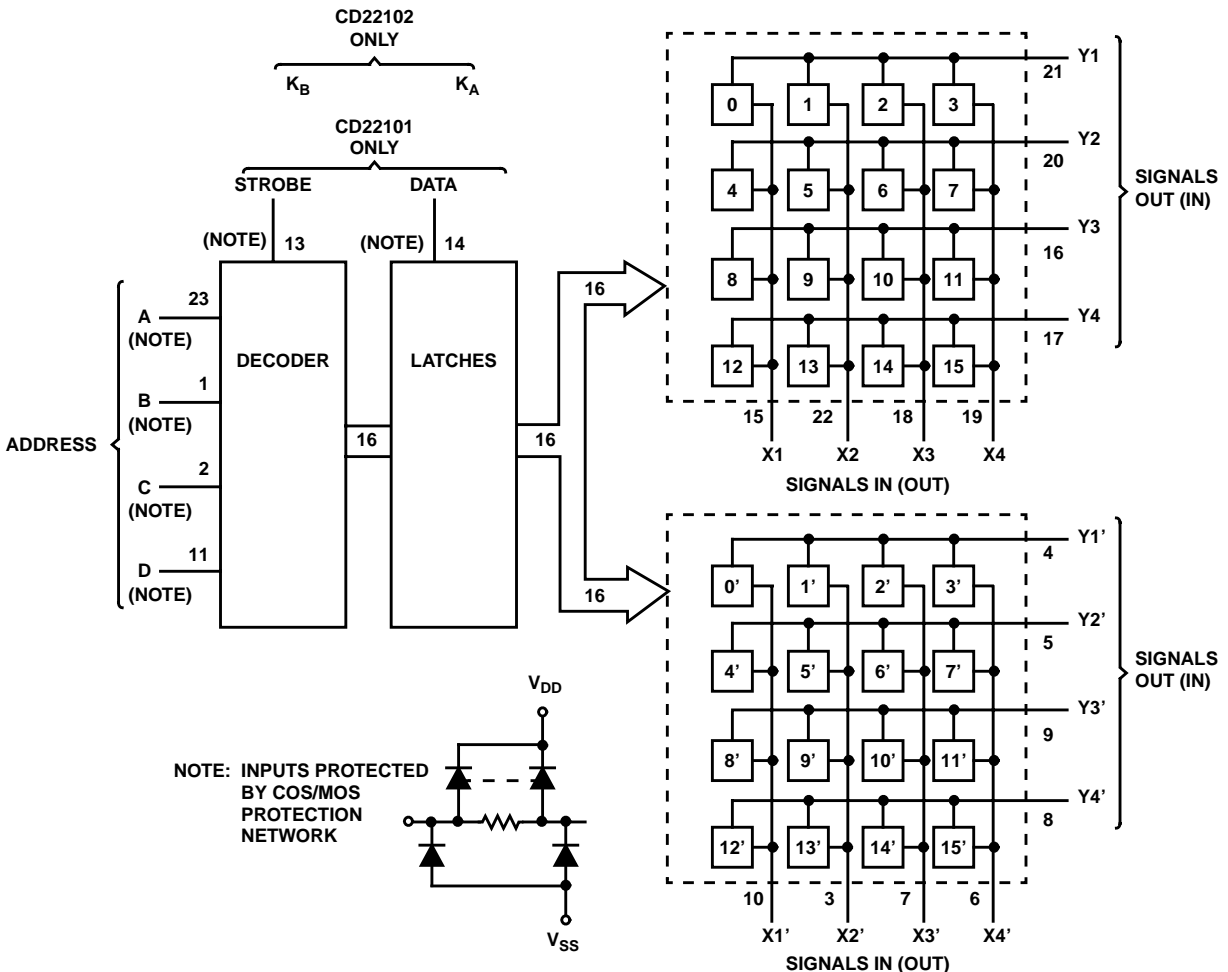

Schematic Diagram

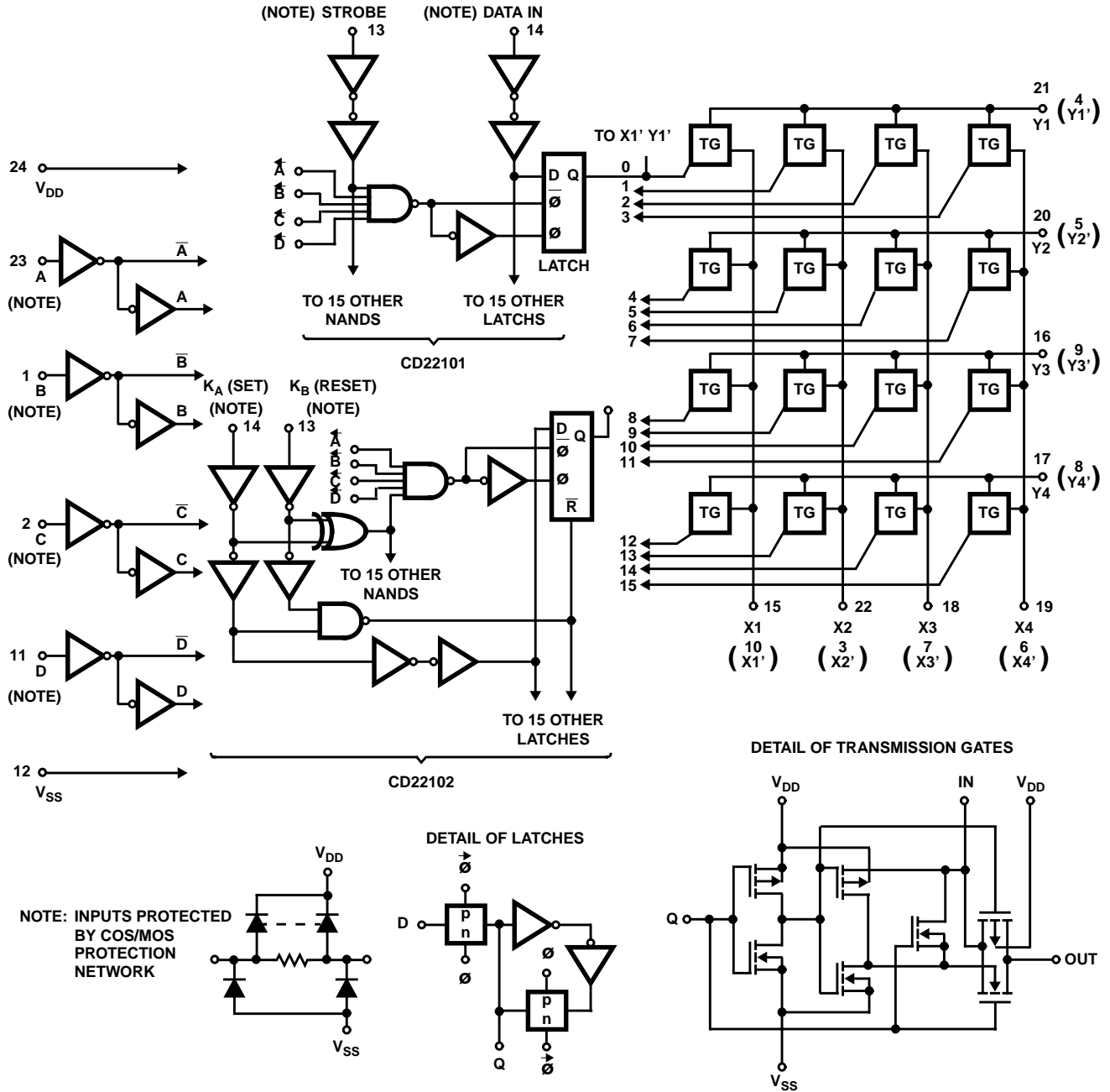

DECODER TRUTH TABLE

ADDRESS				SELECT	ADDRESS				SELECT
A	B	C	D		A	B	C	D	
0	0	0	0	X1Y1 and X1'Y1'	0	0	0	1	X1Y3 and X1'Y3'
1	0	0	0	X2Y1 and X2'Y1'	1	0	0	1	X2Y3 and X2'Y3'
0	1	0	0	X3Y1 and X3'Y1'	0	1	0	1	X3Y3 and X3'Y3'
1	1	0	0	X4Y1 and X4'Y1'	1	1	0	1	X4Y3 and X4'Y3'
0	0	1	0	X1Y2 and X1'Y2'	0	0	1	1	X1Y4 and X1'Y4'
1	0	1	0	X2Y2 and X2'Y2'	1	0	1	1	X2Y4 and X2'Y4'
0	1	1	0	X3Y2 and X3'Y2'	0	1	1	1	X3Y4 and X3'Y4'
1	1	1	0	X4Y2 and X4'Y2'	1	1	1	1	X4Y4 and X4'Y4'

## CD22101, CD22102

**CONTROL TRUTH TABLE FOR CD22101**

FUNCTION	ADDRESS				STROBE	DATA	SELECT
	A	B	C	D			
Switch ON	1	1	1	1	1	1	15 (X4Y4) and 15' (X4'Y4')
Switch OFF	1	1	1	1	1	0	15 (X4Y4) and 15' (X4'Y4')
No Change	X	X	X	X	0	X	X X X X

1 = High Level

0 = Low Level

X = Don't Care

**CONTROL TRUTH TABLE FOR CD22102**

FUNCTION	ADDRESS				K <sub>A</sub>	K <sub>B</sub>	SELECT
	A	B	C	D			
Switch ON	1	1	1	1	1	0	15 (X4Y4) and 15' (X4'Y4')
Switch OFF	1	1	1	1	0	1	15 (X4Y4) and 15' (X4'Y4')
All Switches OFF (Note 5)	X	X	X	X	1	1	All
No Change	X	X	X	X	0	0	X X X X

1 = High Level

0 = Low Level

X = Don't Care

**NOTE:**

5. In the event that K<sub>A</sub> and K<sub>B</sub> are changed from levels 1, 1 to 0, 0 K<sub>B</sub> should not be allowed to go to 0 before K<sub>A</sub>, otherwise a switch which was off will inadvertently be turned on.

### **Metallization Mask Layout**

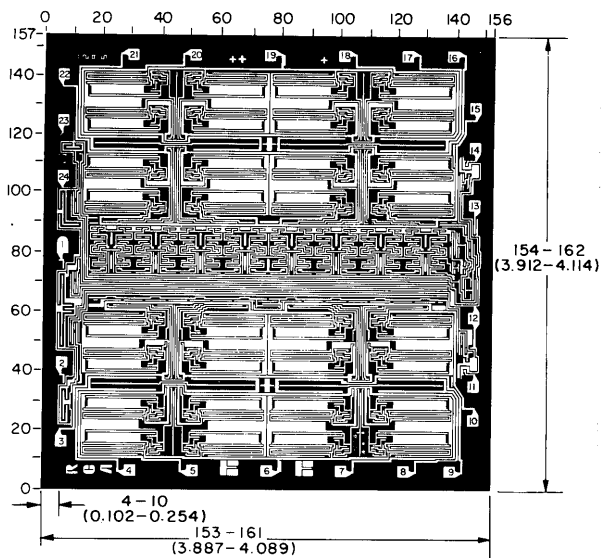
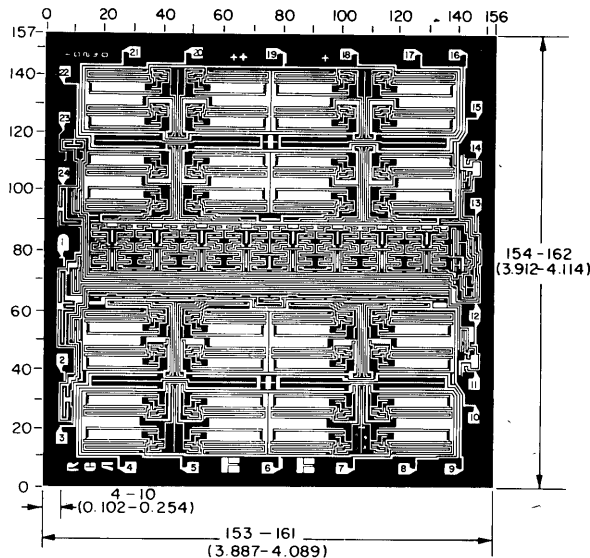

Dimensions in parenthesis are in millimeters and are derived from the basic inch dimensions as indicated. Grid graduations are in mils ( $10^{-3}$  inch).

Test Circuits and Waveforms

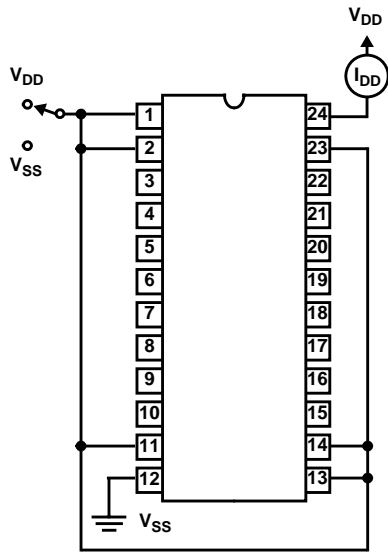
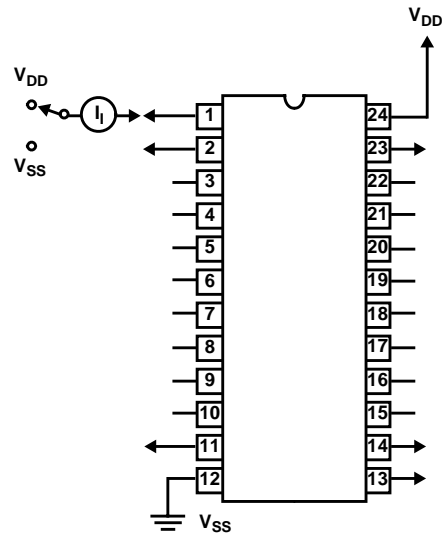
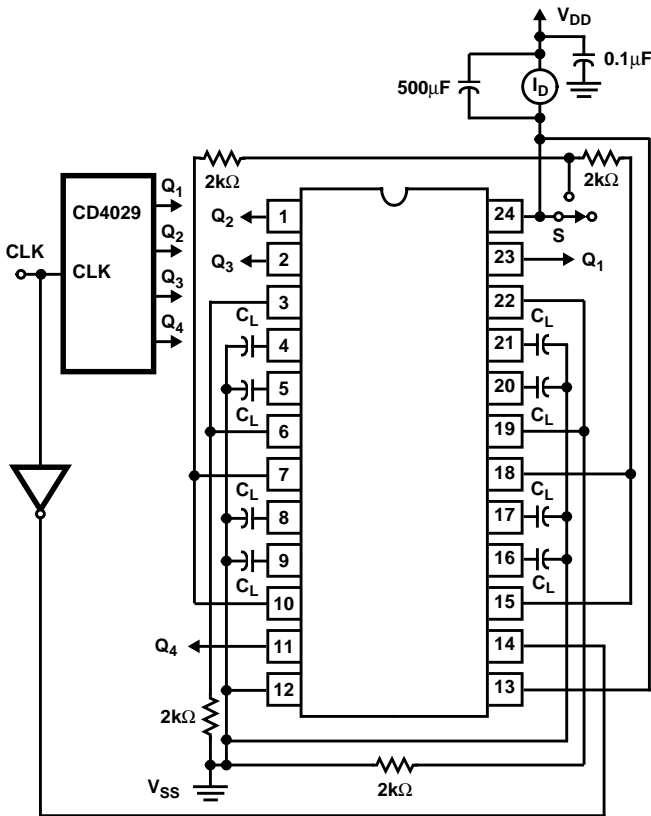

FIGURE 1. QUIESCENT CURRENT TEST CIRCUIT



MEASURE INPUTS SEQUENTIALLY TO BOTH  $V_{DD}$  AND  $V_{SS}$   
CONNECT ALL UNUSED INPUTS TO EITHER  $V_{DD}$  OR  $V_{SS}$

FIGURE 2. INPUT CURRENT TEST CIRCUIT



CLOSE SWITCH S AFTER APPLYING  $V_{DD}$

FIGURE 3. DYNAMIC POWER DISSIPATION TEST CIRCUIT FOR CD22101 AND TYPICAL DYNAMIC POWER DISSIPATION AS A FUNCTION OF SWITCHING FREQUENCY

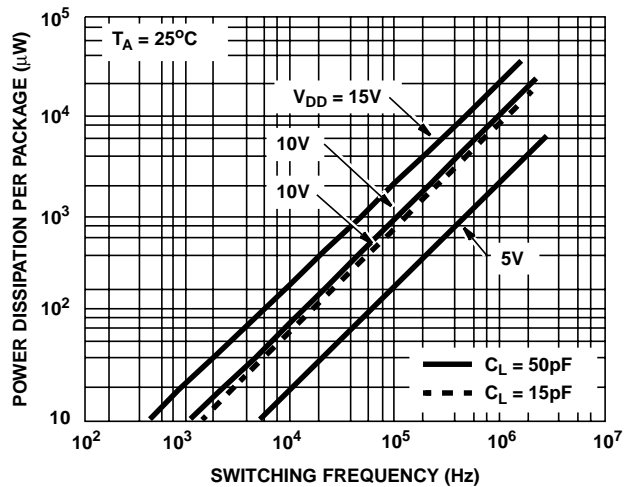



Test Circuits and Waveforms (Continued)

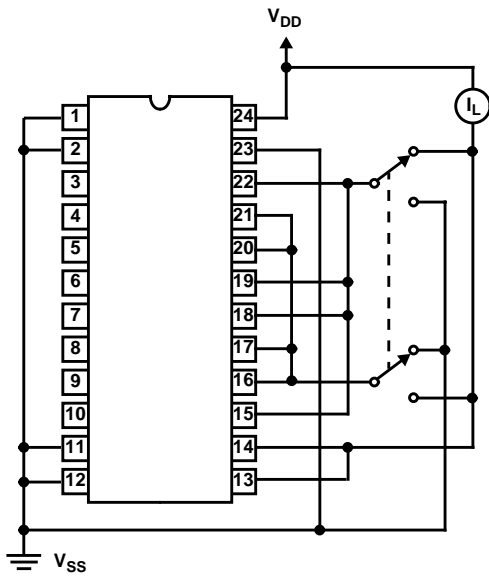
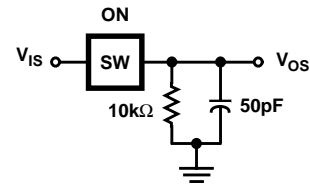

FIGURE 4. OFF SWITCH INPUT OR OUTPUT LEAKAGE CURRENT TEST CIRCUIT (16 OF 32 SWITCHES)



SW = ANY CROSSPOINT  
STROBE = DATA - IN = V<sub>DD</sub>

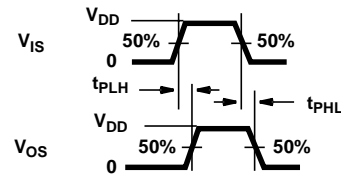
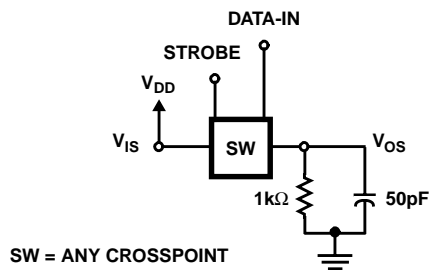

FIGURE 5. PROPAGATION DELAY TIME TEST CIRCUIT AND WAVEFORMS (SIGNAL INPUT TO SIGNAL OUTPUT, SWITCH ON)



SW = ANY CROSSPOINT

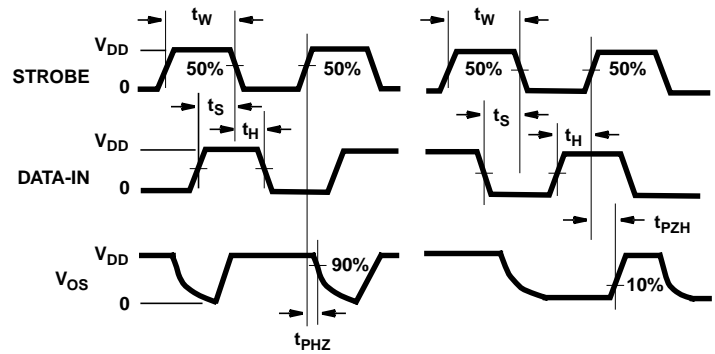

FIGURE 6. PROPAGATION DELAY TIME TEST CIRCUIT AND WAVEFORMS (STROBE TO SIGNAL OUTPUT, SWITCH TURN-ON OR TURN-OFF)

Test Circuits and Waveforms (Continued)

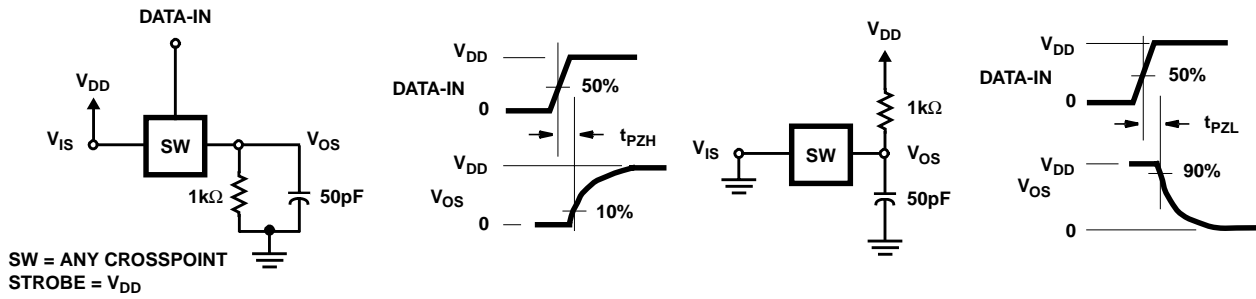

FIGURE 7. PROPAGATION DELAY TIME TEST CIRCUIT AND WAVEFORMS (DATA-IN TO SIGNAL OUTPUT, SWITCH TURN-ON TO HIGH OR LOW LEVEL)

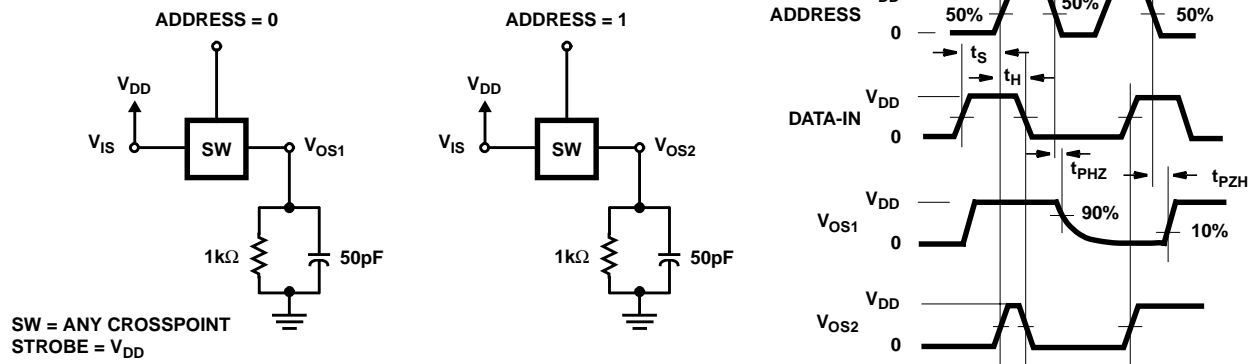
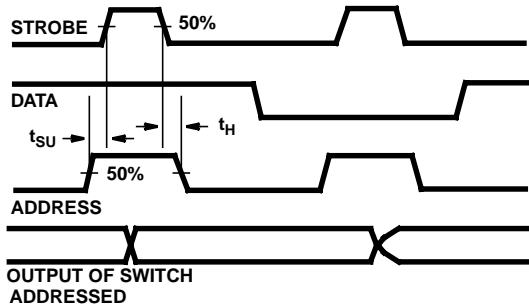
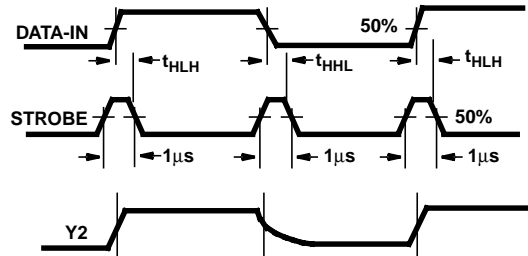

FIGURE 8. PROPAGATION DELAY TIME TEST CIRCUIT AND WAVEFORMS (ADDRESS TO SIGNAL OUTPUT, SWITCH TURN-ON OR TURN-OFF)

Test Circuits and Waveforms (Continued)



IF SETUP AND HOLD TIMES PROVIDED ARE TOO SHORT, AN UNADDRESSED SWITCH MAY BE TURNED ON OR OFF SIMULTANEOUSLY WITH THE ADDRESSED SWITCH



SET ALL SWITCHES TO OFF INITIALLY APPLY VDD TO ALL X INPUTS AND RETURN ALL Y OUTPUTS TO VSS THROUGH 1kΩ ADDRESS X1Y2 (ABCD) WITH  $f_{IN} = 10\text{kHz}$

FIGURE 9. ADDRESS TO STROBE SETUP AND HOLD TIMES

FIGURE 10. STROBE TO DATA-IN HOLD TIME  $t_H$ , FOR CD22101

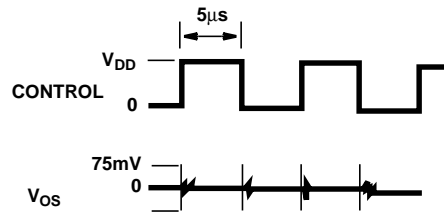
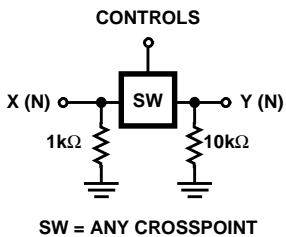

FIGURE 11. TEST CIRCUIT AND WAVEFORMS FOR CROSSTALK (CONTROL INPUT TO SIGNAL OUTPUT)

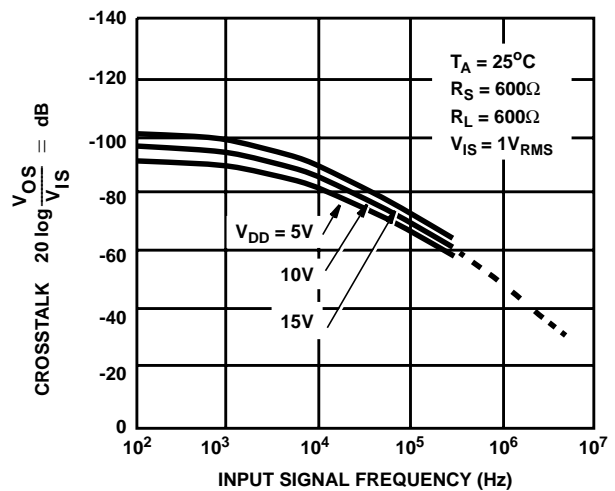
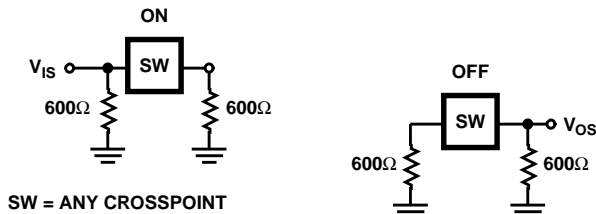

FIGURE 12. TEST CIRCUIT AND TYPICAL CROSSTALK AS A FUNCTION OF FREQUENCY BETWEEN SWITCH CIRCUITS IN THE SAME PACKAGE

Test Circuits and Waveforms (Continued)

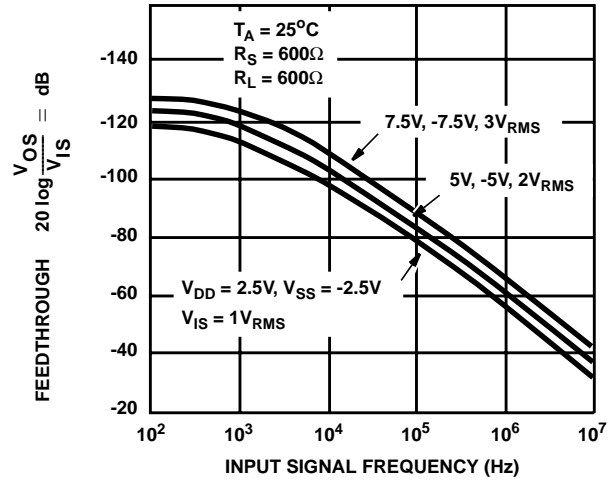
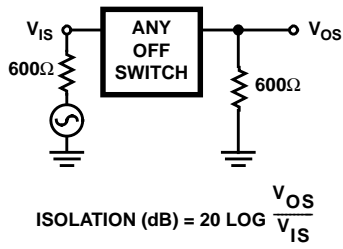

FIGURE 13. TEST CIRCUIT AND TYPICAL FEEDTHROUGH AS A FUNCTION OF FREQUENCY (ANY OFF SWITCH)

Typical Performance Curves

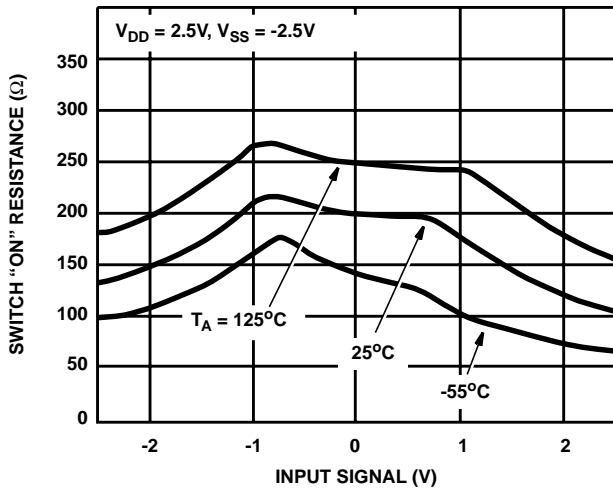

FIGURE 14. TYPICAL ON RESISTANCE AS A FUNCTION OF INPUT SIGNAL VOLTAGE AT  $V_{DD} = -V_{SS} = 2.5V$

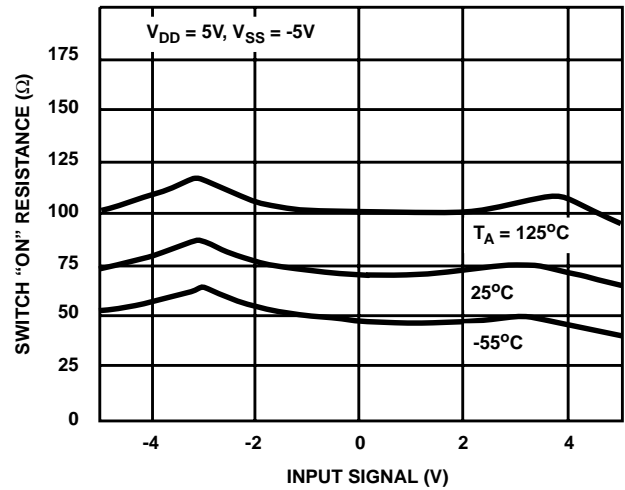

FIGURE 15. TYPICAL ON RESISTANCE AS A FUNCTION OF INPUT SIGNAL VOLTAGE AT  $V_{DD} = -V_{SS} = 5V$

## Typical Performance Curves (Continued)

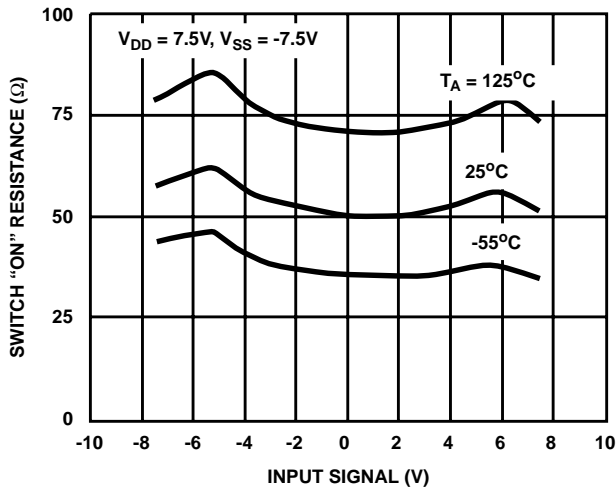

FIGURE 16. TYPICAL ON RESISTANCE AS A FUNCTION OF INPUT SIGNAL VOLTAGE AT  $V_{DD} = -V_{SS} = 7.5\text{V}$

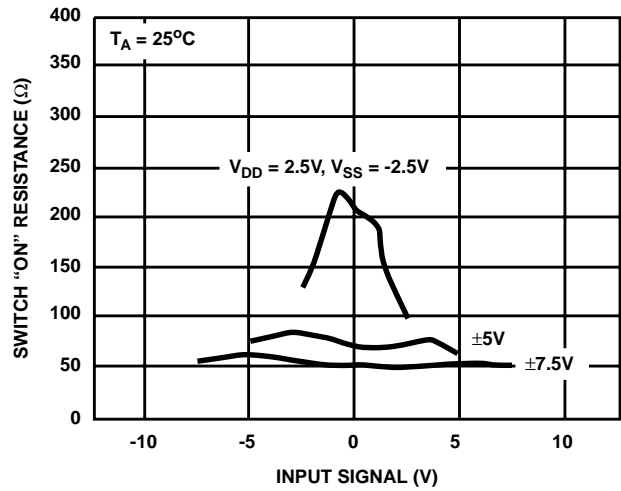

FIGURE 17. TYPICAL ON RESISTANCE AS A FUNCTION OF INPUT SIGNAL VOLTAGE AT  $T_A = 25^\circ\text{C}$

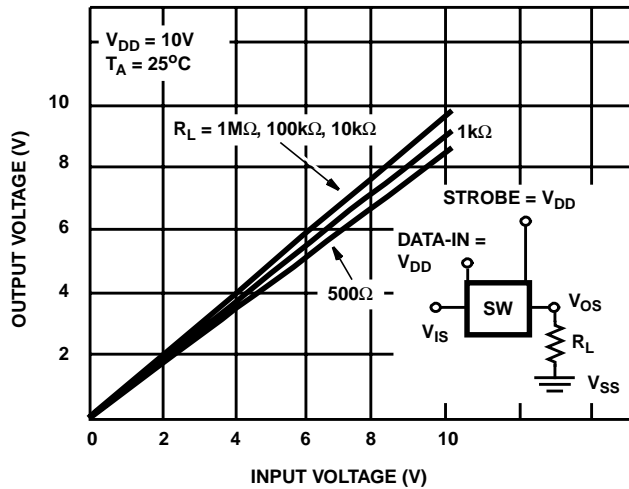

FIGURE 18. TYPICAL SWITCH ON TRANSFER CHARACTERISTICS (1 OF 16 SWITCHES)

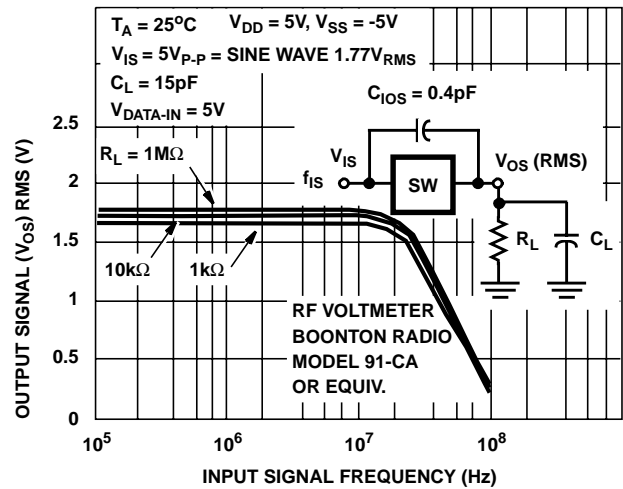

FIGURE 19. TYPICAL SWITCH ON FREQUENCY RESPONSE CHARACTERISTICS