

AN1339 (AN6912N), AN1339S

Quadruple Comparators

Overview

The AN1339 (AN6912N) and the AN1339S are quadruple (voltage) comparators with wide range of operating supply voltages.

Features

- Wide range of supply voltage
Single supply: 2 to 36V
Dual supply: ± 1 to ± 18 V
- Low circuit current: 0.8mA typ.
- Wide range of common-mode input voltages
: 0V to $V_{CC} - 1.5$ V (single supply)
- Open collector output

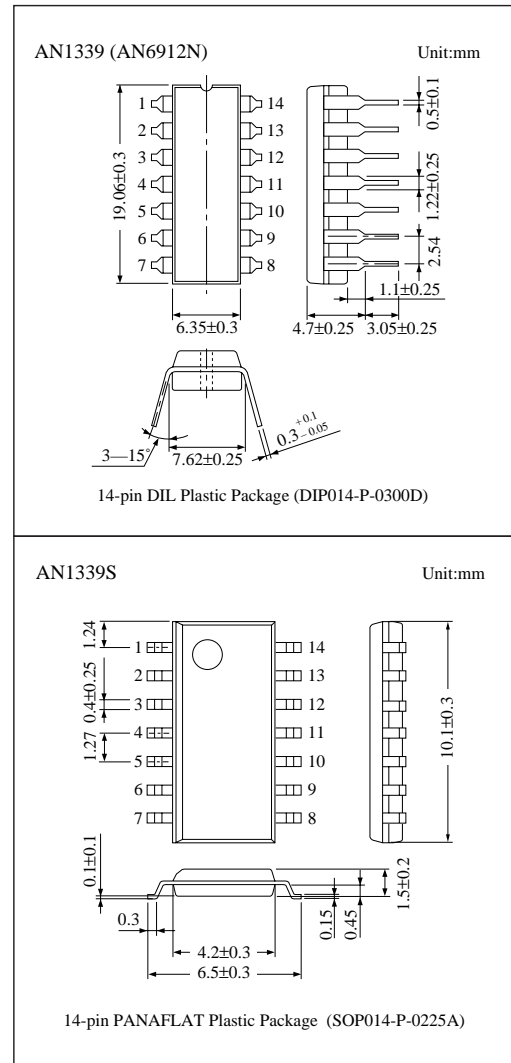

Block Diagram

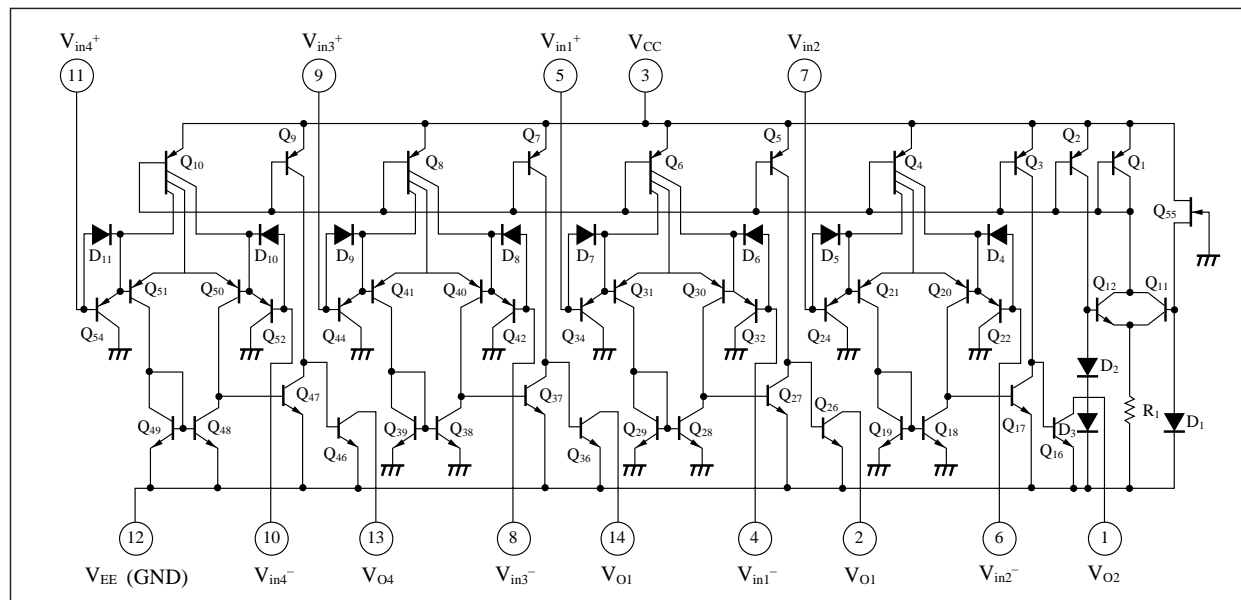

■ Pin Descriptions

Pin No.	Pin name	Pin No.	Pin name
1	Ch.2 output	8	Ch.3 inverting input
2	Ch.1 output	9	Ch.3 non inverting input
3	V _{CC}	10	Ch.4 inverting input
4	Ch.1 inverting input	11	Ch.4 non inverting input
5	Ch.1 non inverting input	12	V _{EE} (GND)
6	Ch.2 inverting input	13	Ch.4 output
7	Ch.2 non inverting input	14	Ch.3 output

■ Absolute Maximum Ratings (Ta=25°C)

Parameter		Symbol	Rating	Unit
Voltage	Supply voltage	V _{CC}	36	V
	Common-mode input voltage	V _{ICM} *1	-0.3 to +36	V
	Differential input voltage	V _{ID} *2	36	V
Power dissipation	AN1339 (AN6912N)	P _D	570	mW
	AN1339S		380	
Operating ambient temperature		T _{opr}	-30 to +85	°C
Storage temperature	AN1339 (AN6912N)	T _{stg}	-55 to +150	°C
	AN1339S		-55 to +125	

*1 The common mode input voltage is a voltage applied to the non-inverting input pin and inverting input pin simultaneously.

*2 Differential input is equivalent to the potential difference between the non-inverting input pin and inverting input pin.

■ Electrical Characteristics (V_{CC}=5V, Ta=25±2°C)

Parameter	Symbol	Condition	min	typ	max	Unit
Input offset voltage	V _{I (offset)}		—	2	5	mV
Input offset current	I _{IO}		—	—	50	nA
Input bias current	I _{Bias}		—	—	250	nA
Voltage gain	G _V	R _L =15kΩ	—	200	—	V/mV
Common-mode input voltage range	V _{CM}		0	—	V _{CC} -1.5	V
Supply current	I _{CC}	R _L = ∞	—	1.1	2	mA
Response time	t _r	R _L =5.1kΩ, V _{RL} =5V	—	1.3	—	μs
Output sink current	I _{SINK}	V _{REF} =0V, V _{IN} =1V, V _O ≤ 1.5V	10	—	—	mA
Low-level output voltage	V _{OL}	V _{REF} =0V, V _{IN} =1V, I _{SINK} =3mA	—	0.2	0.4	V
Output terminal leakage current	I _{O (Leak)}	V _{IN} =0V, V _{REF} =1V, V _O =5V	—	0.1	—	nA

■ Block Diagram

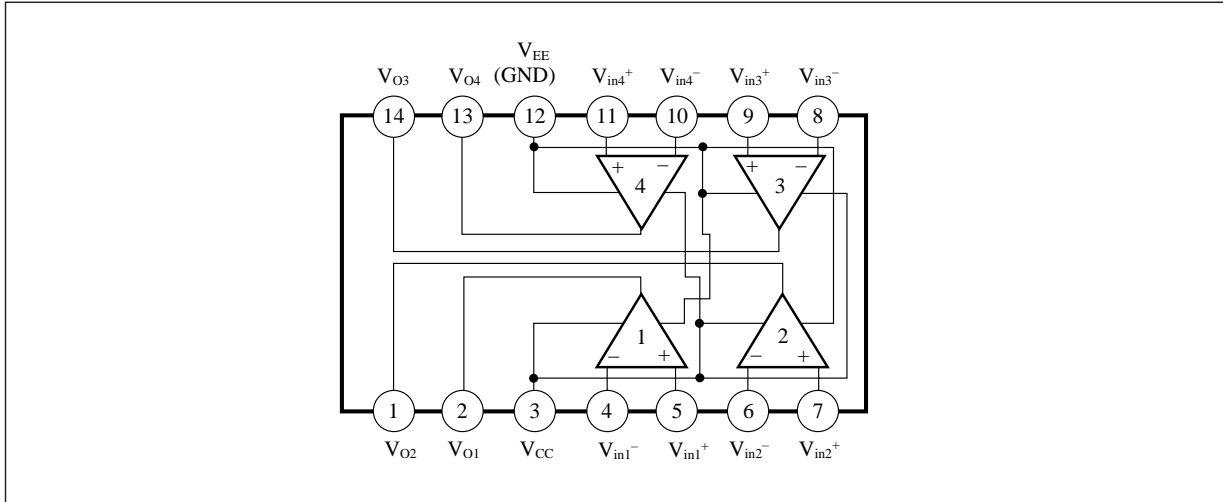

■ Characteristics Curve

