

---

# HA17008RP/RFP

## 8-Bit Multiplying Digital to Analog Converter

# HITACHI

ADE-204-060 (Z)

Rev. 0

Dec. 2000

---

### Description

The HA17008R series are 8-bit monolithic D/A converters which have built in, a reference current amplifier, an R-2R ladder resistor, and 8 high speed current switches.

By setting the reference voltage and resistance, the maximum output current can be freely varied in response to the application.

The reference current is distributed to the current value for each bit by the R-2R ladder resistor, and the maximum output current is 255/256 of the reference current. For example, if the input reference current is 2.0 mA, then the maximum available output current is 1.992 mA.

Applications for the HA17008R are wide ranging, and include CRT displays, stepping motor control, programmable power supplies, audio equipment, and attenuators.

### Features

- Linearity of  $\pm 0.19\%$  ( $\pm 1/2$  LSB) guaranteed.
- The settling time is short, 85 ns (typ), enabling rapid conversions.
- Low power dissipation has been reduced: 135 mW typ.
- Compatible with TTL and CMOS logic.
- The standard supply voltage is  $V_{CC} = +15.0$  V,  $V_{EE} = -15.0$  V.
- A wide output voltage range can be provided. From  $-10$  V to  $+18$  V.

### Ordering Information

Type No.	Package
HA17008RP	DP-16
HA17008RFP	FP-16DA

---



# HA17008RP/RFP

## Pin Arrangement

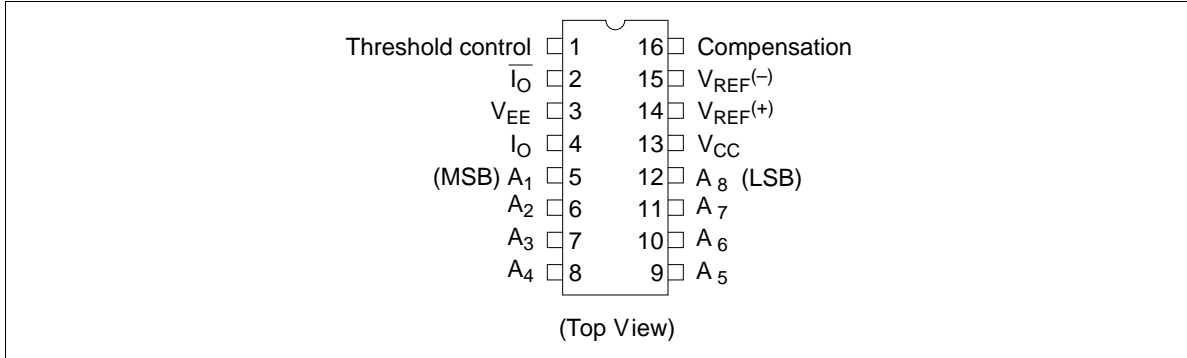

## Block Diagram

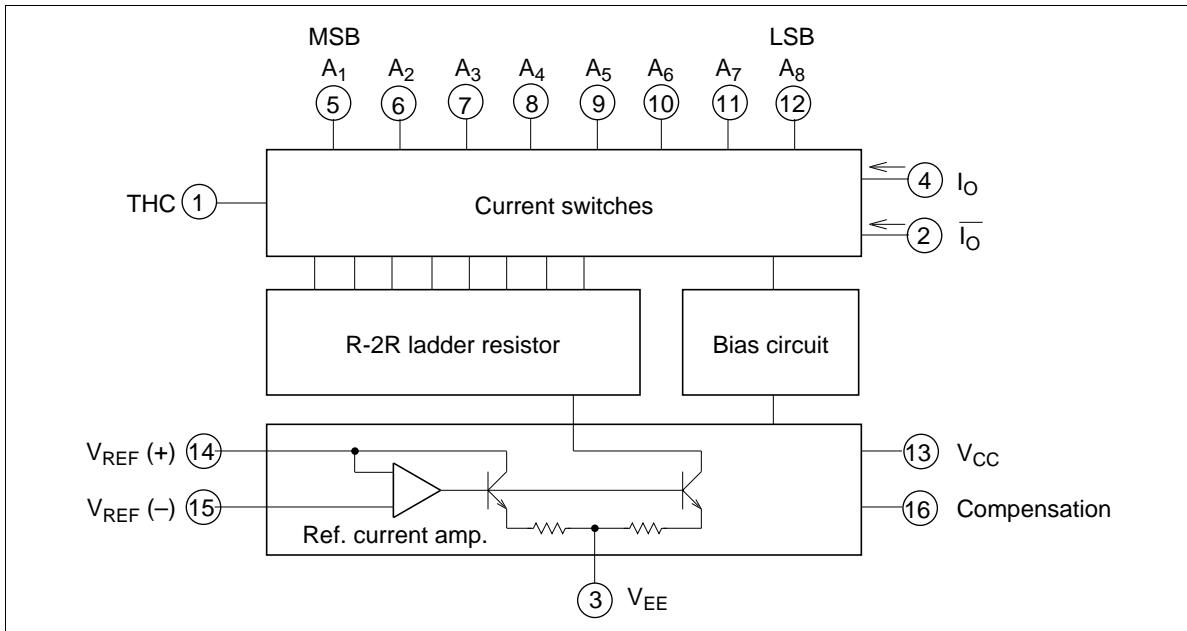

HITACHI

## Functions

### Reference differential amplifier and phase compensation

The reference amplifier is a circuit which converts the reference voltage applied to pin 14 through the external resistor  $R_{14}$  from a voltage to a current. The converted current is supplied to each bit by a current mirror and the ladder resistor. Note that this should be used with the polarity of the current flowing in to pin 14. The reference voltage source provides all of the current flowing into pin 14.

Also, even removing the resistor  $R_{15}$  will have a minimal influence on precision and temperature drift.

To preserve an appropriate value of the phase margin, it is necessary to increase the value of the phase compensation capacitance as  $R_{14}$  is increased. For example, if  $R_{14}$  is 1 k , 2.5 k , or

5 k , the minimum capacitances should be 15 pF, 37 pF, and 75 pF, respectively. The capacitor is connected to  $V_{EE}$ . If high impedance is required in the reference current source, connect  $R_{14}$  to ground and connect  $R_{15}$  to the negative reference voltage. (Refer figure 2.) If a DC reference voltage is used, a bypass capacitor should be inserted in the reference voltage source to reduce compounded hum and noise. We cannot recommend the use of noisy 5 V logic power supplies. When a logic control 5 V power supply of good stability is used for the reference supply, connect a resistor to the reference supply and connect a 0.1  $\mu$ F capacitor between the reference supply and the resistor contact.

When pin 14 is controlled by a high impedance such as a fixed current supply, phase compensation will not be possible with the above method. Therefore, provide adequate phase compensation in the frequency band of the fixed current supply.

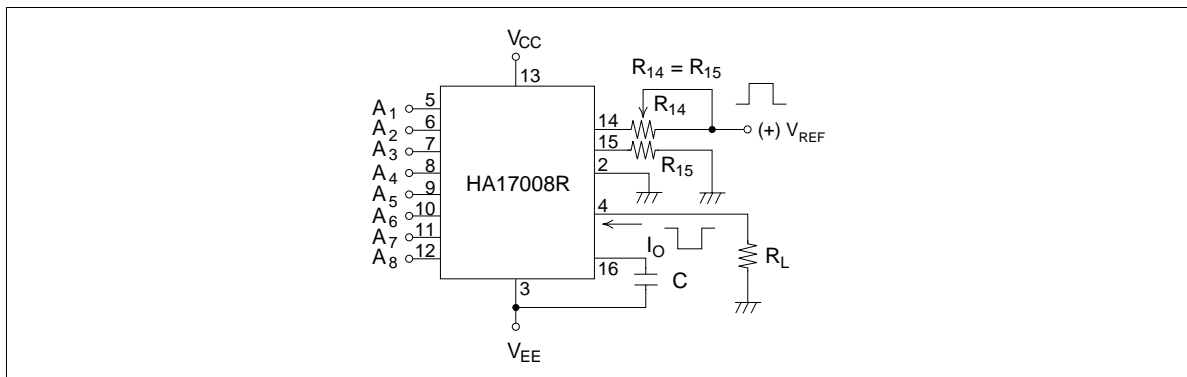

**Figure 1 Positive Reference Potential Application Example**

# HA17008RP/RFP

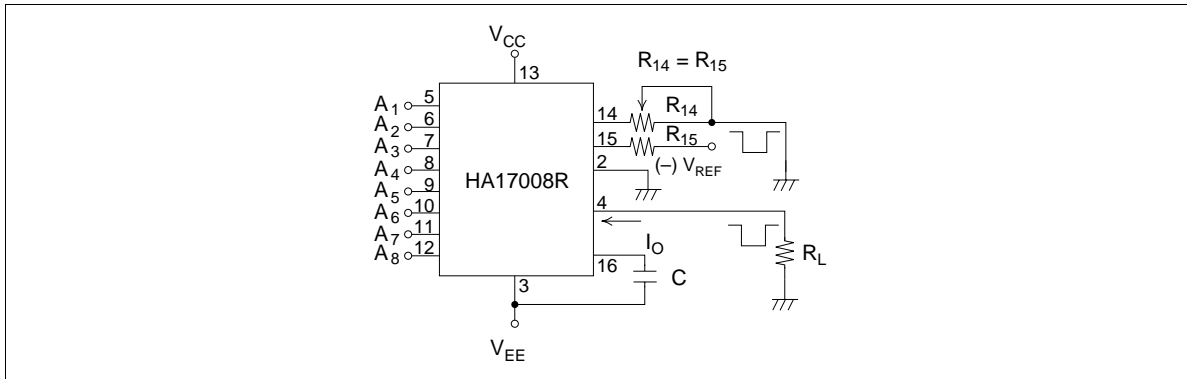

Figure 2 Negative Reference Potential Application Example

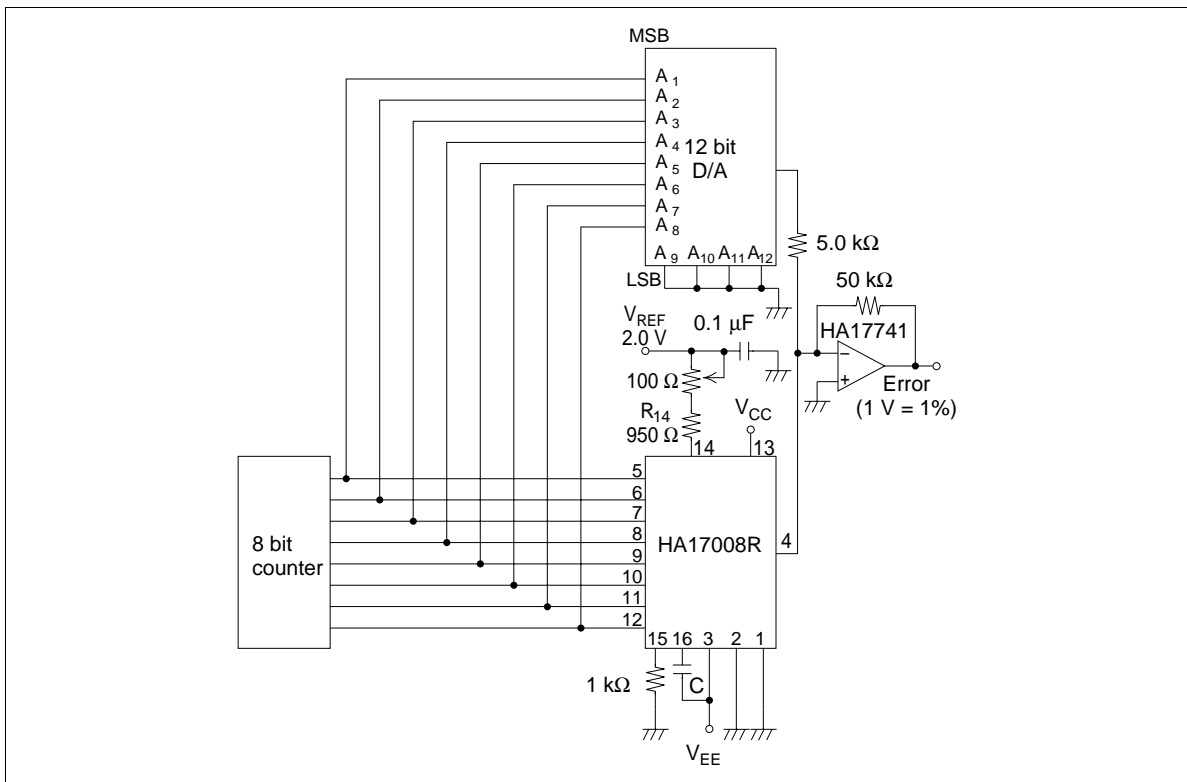

Figure 3 Non Linearity Measurement Circuit

HITACHI

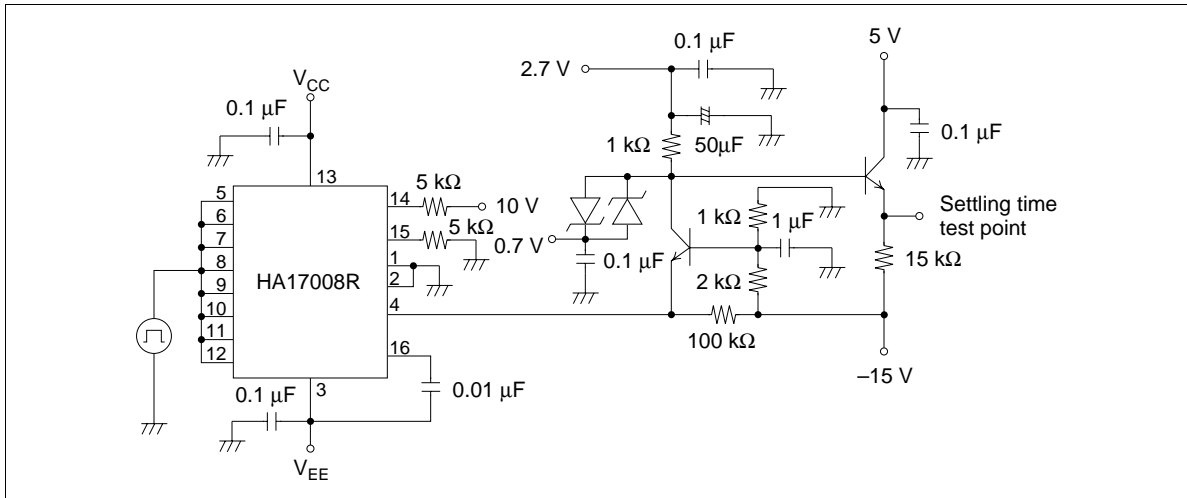
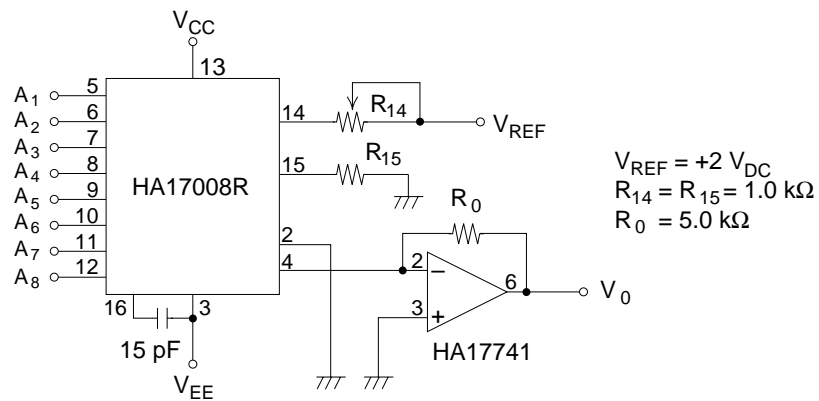

Figure 4 Settling Time Test Circuit

Operation Example

- Current to voltage converter using an op-amp



Logical output  $V_0$

$$V_0 = \frac{V_{REF}}{R_{14}} (R_0) \left( \frac{A_1}{2} + \frac{A_2}{4} + \frac{A_3}{8} + \frac{A_4}{16} + \frac{A_5}{32} + \frac{A_6}{64} + \frac{A_7}{128} + \frac{A_8}{256} \right)$$

When  $V_{REF}$ ,  $R_{14}$ , and  $R_0$  are determined, the output voltage becomes 9.961 V in case of all-high input bits.

$$V_0 = \frac{2V}{1k\Omega} (5k\Omega) \left( \frac{1}{2} + \frac{1}{4} + \frac{1}{8} + \frac{1}{16} + \frac{1}{32} + \frac{1}{64} + \frac{1}{128} + \frac{1}{256} \right)$$

---

## HA17008RP/RFP

---

### Absolute Maximum Ratings (Ta = 25°C)

Item	Symbol	Rating	Unit
Power supply voltage	V <sub>CC</sub>	+18	V
	V <sub>EE</sub>	-18	V
Digital input voltage	V <sub>5</sub> to V <sub>12</sub>	V <sub>EE</sub> to V <sub>EE</sub> + 36 V	V
Reference current	I <sub>14</sub>	5	mA
Reference amplifier input voltage range	V <sub>REF</sub>	V <sub>CC</sub> to V <sub>EE</sub>	V
Power dissipation	P <sub>T</sub>	500* <sup>1</sup>	mW
Operating temperature	T <sub>opr</sub>	-20 to +75	°C
Storage temperature	T <sub>stg</sub>	-55 to +125	°C

Note: 1. This is the allowable value up to Ta = 65°C for HA17008RP. Derate by 8.3mW/°C above that temperature.

In case of HA17008RFP, see notes on SOP Package usage in Reliability section.

**Electrical Characteristics** ( $V_{CC} = 15\text{ V}$ ,  $V_{EE} = -15\text{ V}$ ,  $I_{REF} = 2\text{ mA}$ ,  $V_{THC} = 0\text{ V}$ ,  $T_a = 25^\circ\text{C}$ )

Item	Symbol	Min	Typ	Max	Unit	Test Conditions
Nonlinearity	NL	—	—	±0.19	%FS	
Settling time ( $\pm 1/2$ LSB)	$t_s$	—	85	150	ns	All bits OFF to ON
Propagation delay time	$t_{PLH}$ , $t_{PHL}$	—	35	60	ns	
Full scale current temperature dependence	$T_{CIFS}$	—	±10	±50	ppm/°C	
Digital input level	$V_{IH}$	2	—	—	V	
	$V_{IL}$	—	—	0.8	V	
Digital input current (MSB)	$I_{IH}$	—	0.002	10	μA	$V_{IH} = 5\text{ V}$
	$I_{IL}$	-10	-2	—	μA	$V_{IL} = 0.8\text{ V}$
Reference input bias current	$I_{I5}$	-3	-1	—	μA	
Output current range	$I_{F5R}$	0	2	2.1	mA	$V_{EE} = -5\text{ V}$
		0	2	4.2	mA	$V_{EE} = -8\text{ to }-18\text{ V}$
Full scale output current	$I_{FS}$	1.94	1.99	2.04	mA	$V_{ref} = 10\text{ V}$ , $R_{14}$ , $R_{15} = 5\text{ k}\Omega$
Zero scale output current	$I_z$	—	0	2	μA	All Bits Low
Output voltage range	$V_{OC}$	-10	—	+18	V	$\Delta I_{FS} \leq 1/2\text{ LSB}$
Reference current slew rate	$dl/dt$	4	8	—	mA/μs	$R_{REF} \leq 200\Omega$ , $C_C = 0\text{ pf}$
Power supply current	$I_{CC}$	—	1.8	3.8	mA	$V_{CC} = 5\text{ V}$ , $I_{REF} = 1\text{ mA}$ ,
	$I_{EE}$	-5.8	-3.7	—	mA	$V_{EE} = -5\text{ V}$
	$I_{CC}$	—	1.9	3.8	mA	$V_{CC} = 5\text{ V}$ , $I_{REF} = 2\text{ mA}$ ,
	$I_{EE}$	-7.8	-5.8	—	mA	$V_{EE} = -15\text{ V}$
	$I_{CC}$	—	2.1	3.8	mA	$V_{CC} = 15\text{ V}$ , $I_{REF} = 2\text{ mA}$ ,
Power supply voltage	$I_{EE}$	-7.8	-5.9	—	mA	$V_{EE} = -15\text{ V}$
	$V_{CC}$	4.5	15	18	V	$I_{REF} = 1\text{ mA}$
Power supply voltage dependence	$V_{EE}$	-18	-15	-4.5	V	
	Differential full scale output current difference	$I_{FSS}$	-8	±1	+8	μA
Digital input voltage range	$V_{IS}$	-10	—	+18	V	$V_{THR} = -10\text{ to }+13.5\text{ V}$
Threshold voltage range	$V_{THR}$	-10	0	13.5	V	$V_{THR} \equiv V_{THC} + 1.3\text{ V}$
Power supply voltage dependence	$P_{SS} I_{FS+}$	-100	—	100	ppmFS/%V	$V_{CC} = -4.5\text{ to }-18\text{ V}$ , $I_{REF} = 1\text{ mA}$
	$P_{SS} I_{FS-}$	-100	—	100	ppmFS/%V	$V_{EE} = -4.5\text{ to }-18\text{ V}$ , $I_{REF} = 1\text{ mA}$

## Standard Characteristics Curves

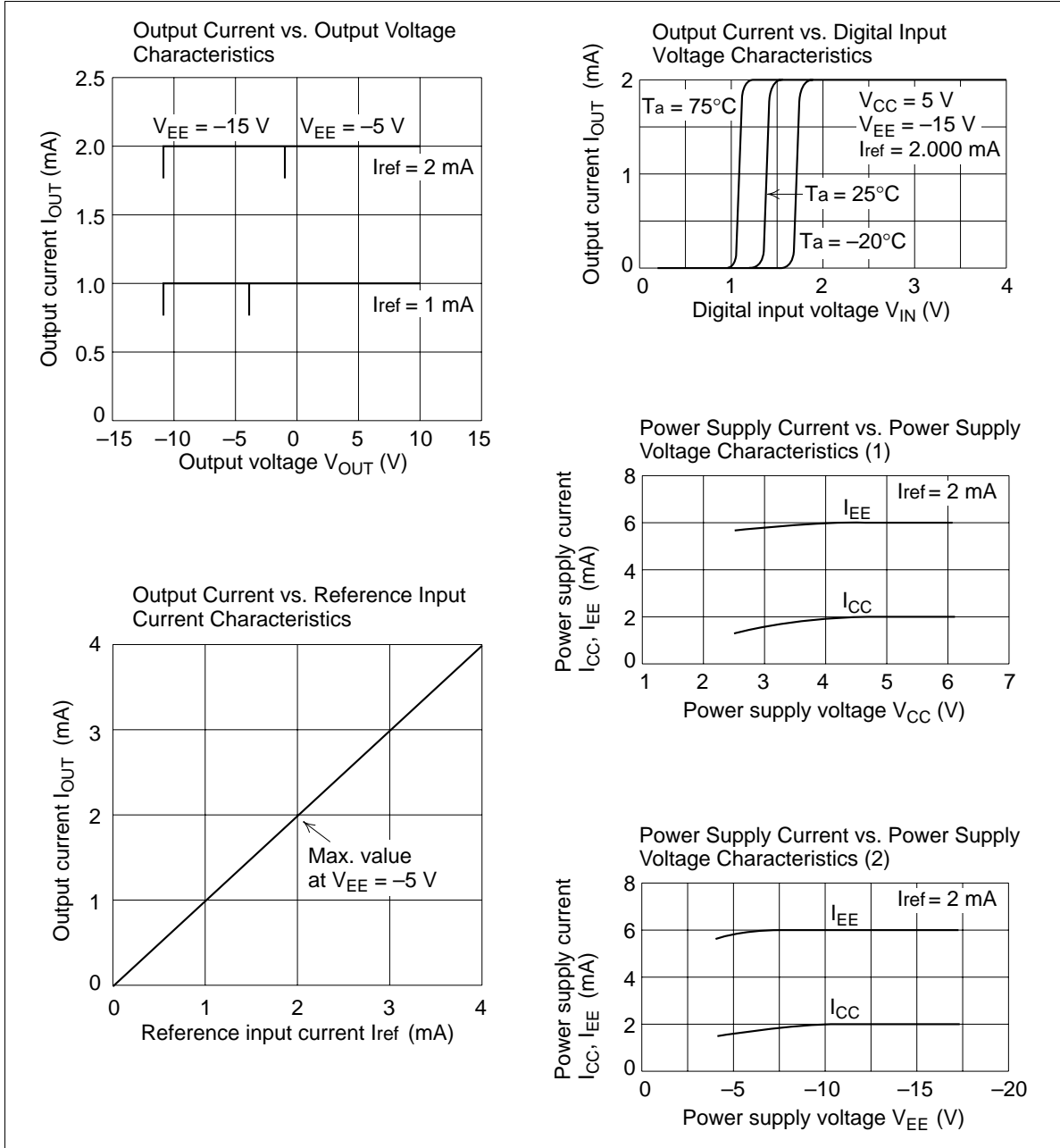



Standard Characteristics Curves (cont)

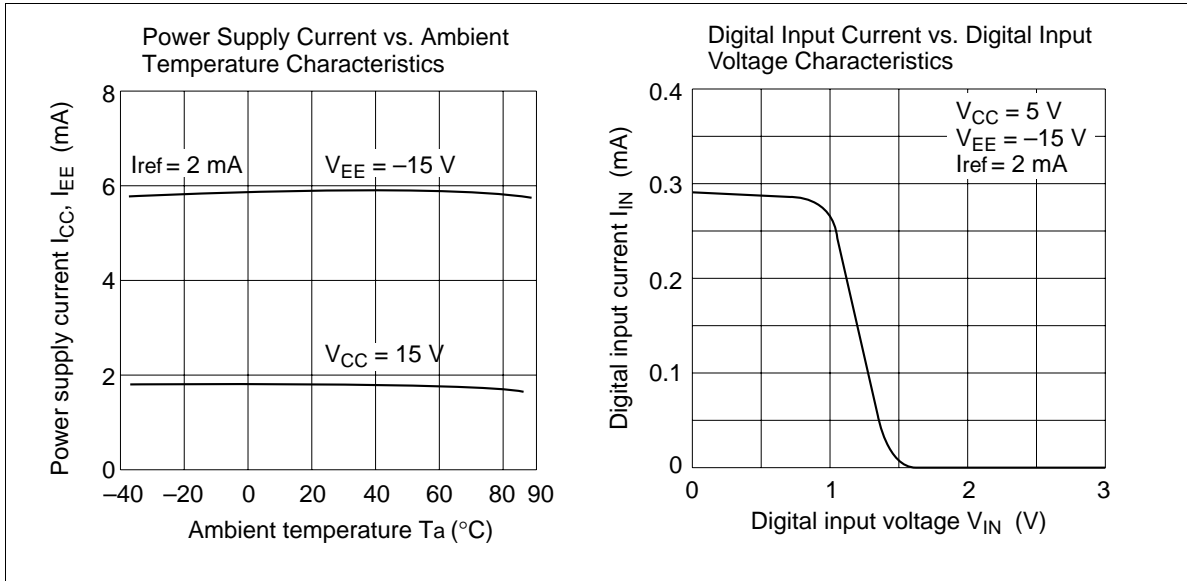

# HA17008RP/RFP

## Package Dimensions

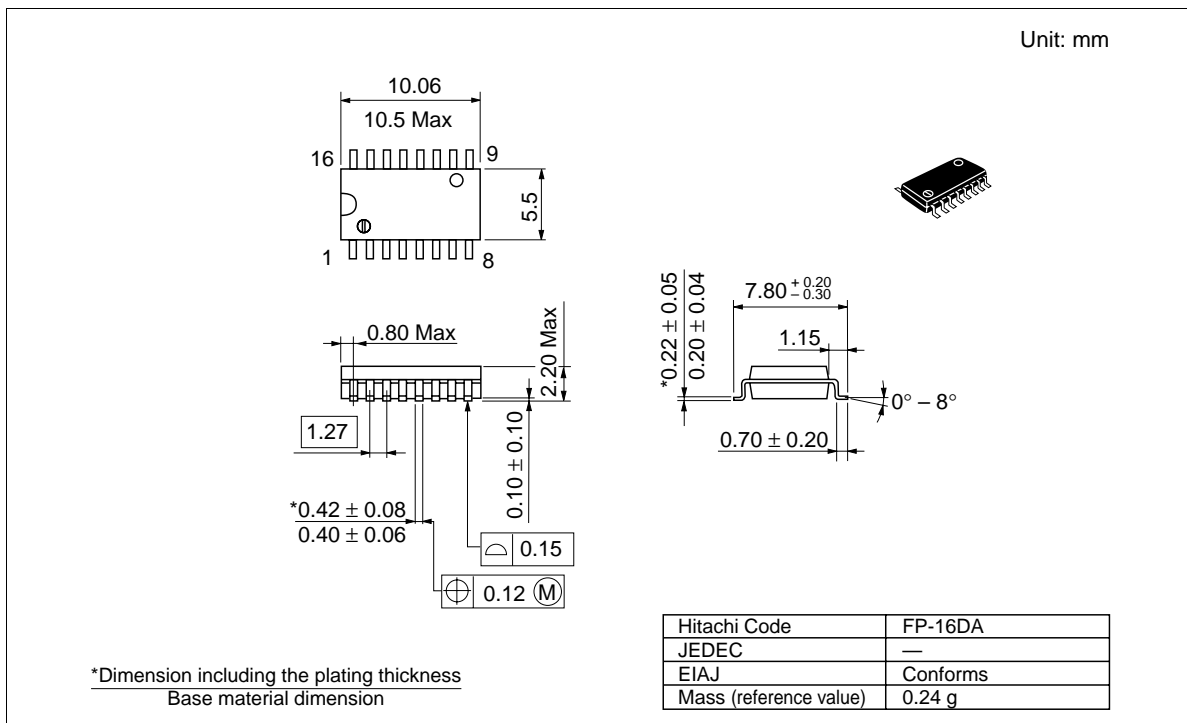
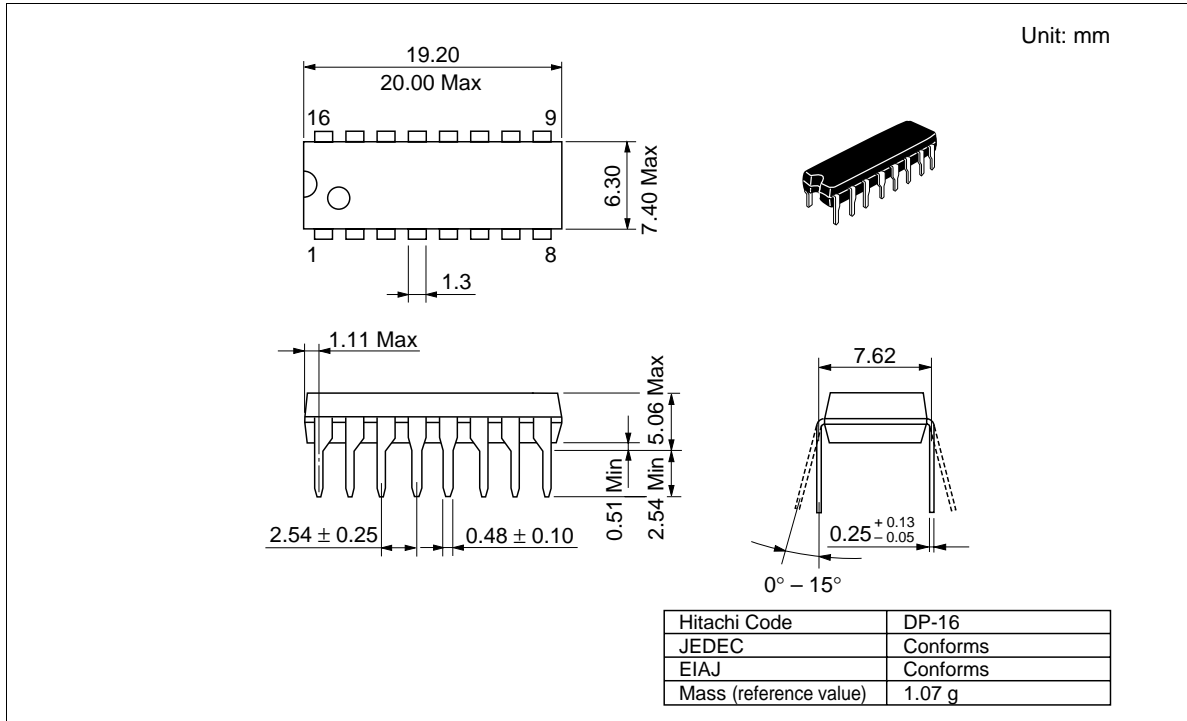

**HITACHI**

**Cautions**

1. Hitachi neither warrants nor grants licenses of any rights of Hitachi's or any third party's patent, copyright, trademark, or other intellectual property rights for information contained in this document. Hitachi bears no responsibility for problems that may arise with third party's rights, including intellectual property rights, in connection with use of the information contained in this document.
2. Products and product specifications may be subject to change without notice. Confirm that you have received the latest product standards or specifications before final design, purchase or use.
3. Hitachi makes every attempt to ensure that its products are of high quality and reliability. However, contact Hitachi's sales office before using the product in an application that demands especially high quality and reliability or where its failure or malfunction may directly threaten human life or cause risk of bodily injury, such as aerospace, aeronautics, nuclear power, combustion control, transportation, traffic, safety equipment or medical equipment for life support.
4. Design your application so that the product is used within the ranges guaranteed by Hitachi particularly for maximum rating, operating supply voltage range, heat radiation characteristics, installation conditions and other characteristics. Hitachi bears no responsibility for failure or damage when used beyond the guaranteed ranges. Even within the guaranteed ranges, consider normally foreseeable failure rates or failure modes in semiconductor devices and employ systemic measures such as fail-safes, so that the equipment incorporating Hitachi product does not cause bodily injury, fire or other consequential damage due to operation of the Hitachi product.
5. This product is not designed to be radiation resistant.
6. No one is permitted to reproduce or duplicate, in any form, the whole or part of this document without written approval from Hitachi.
7. Contact Hitachi's sales office for any questions regarding this document or Hitachi semiconductor products.

# HITACHI

**Hitachi, Ltd.**

Semiconductor & Integrated Circuits.  
Nippon Bldg., 2-6-2, Ohte-machi, Chiyoda-ku, Tokyo 100-0004, Japan  
Tel: Tokyo (03) 3270-2111 Fax: (03) 3270-5109

URL      NorthAmerica      : <http://semiconductor.hitachi.com/>  
              Europe                : <http://www.hitachi-eu.com/hel/ecg>  
              Asia                         : <http://sicapac.hitachi-asia.com>  
              Japan                        : <http://www.hitachi.co.jp/Sicd/indx.htm>

**For further information write to:**

Hitachi Semiconductor  
(America) Inc.  
179 East Tasman Drive,  
San Jose, CA 95134  
Tel: <1> (408) 433-1990  
Fax: <1> (408) 433-0223

Hitachi Europe GmbH  
Electronic Components Group  
Dornacher Straße 3  
D-85622 Feldkirchen, Munich  
Germany  
Tel: <49> (89) 9 9180-0  
Fax: <49> (89) 9 29 30 00

Hitachi Europe Ltd.  
Electronic Components Group.  
Whitebrook Park  
Lower Cookham Road  
Maidenhead  
Berkshire SL6 8YA, United Kingdom  
Tel: <44> (1628) 585000  
Fax: <44> (1628) 585160

Hitachi Asia Ltd.  
Hitachi Tower  
16 Collyer Quay #20-00,  
Singapore 049318  
Tel: <65>-538-6533/538-8577  
Fax: <65>-538-6933/538-3877  
URL : <http://www.hitachi.com.sg>

Hitachi Asia Ltd.  
(Taipei Branch Office)  
4/F, No. 167, Tun Hwa North Road,  
Hung-Kuo Building,  
Taipei (105), Taiwan  
Tel: <886>-(2)-2718-3666  
Fax: <886>-(2)-2718-8180  
Telex: 23222 HAS-TP  
URL : <http://www.hitachi.com.tw>

Hitachi Asia (Hong Kong) Ltd.  
Group III (Electronic Components)  
7/F., North Tower,  
World Finance Centre,  
Harbour City, Canton Road  
Tsim Sha Tsui, Kowloon,  
Hong Kong  
Tel : <852>-(2)-735-9218  
Fax : <852>-(2)-730-0281  
URL : <http://www.hitachi.com.hk>

Copyright © Hitachi, Ltd., 2000. All rights reserved. Printed in Japan.  
Colophon 2.0

# HITACHI