

DATA SHEET

TDA7053

**2 x 1 W portable/mains-fed stereo
power amplifier**

Product specification
File under Integrated Circuits, IC01

February 1994

2 x 1 W portable/mains-fed stereo power amplifier

TDA7053

GENERAL DESCRIPTION

The TDA7053 is an integrated class-B stereo power amplifier in a 16-lead dual-in-line (DIL) plastic package. The device, consisting of two BTL amplifiers, is primarily developed for portable audio applications but may also be used in mains-fed applications.

Features

- No external components
- No switch-ON/OFF clicks
- Good overall stability
- Low power consumption
- Short-circuit-proof.

QUICK REFERENCE DATA

PARAMETER	CONDITIONS	SYMBOL	MIN.	TYP.	MAX.	UNIT
Supply voltage range		V_P	3	6	18	V
Total quiescent current	$R_L = \infty$	I_{tot}	–	9	16	mA
Output power	$R_L = 8 \Omega$; $V_P = 6 V$	P_O	–	1.2	–	W
Internal voltage gain		G_v	38	39	40	dB
Total harmonic distortion	$P_O = 0.1 W$	THD	–	0.2	1.0	%

PACKAGE OUTLINE

16-lead DIL; plastic (SOT38); SOT38-1; 1996 July 24.

2 x 1 W portable/mains-fed stereo
power amplifier

TDA7053

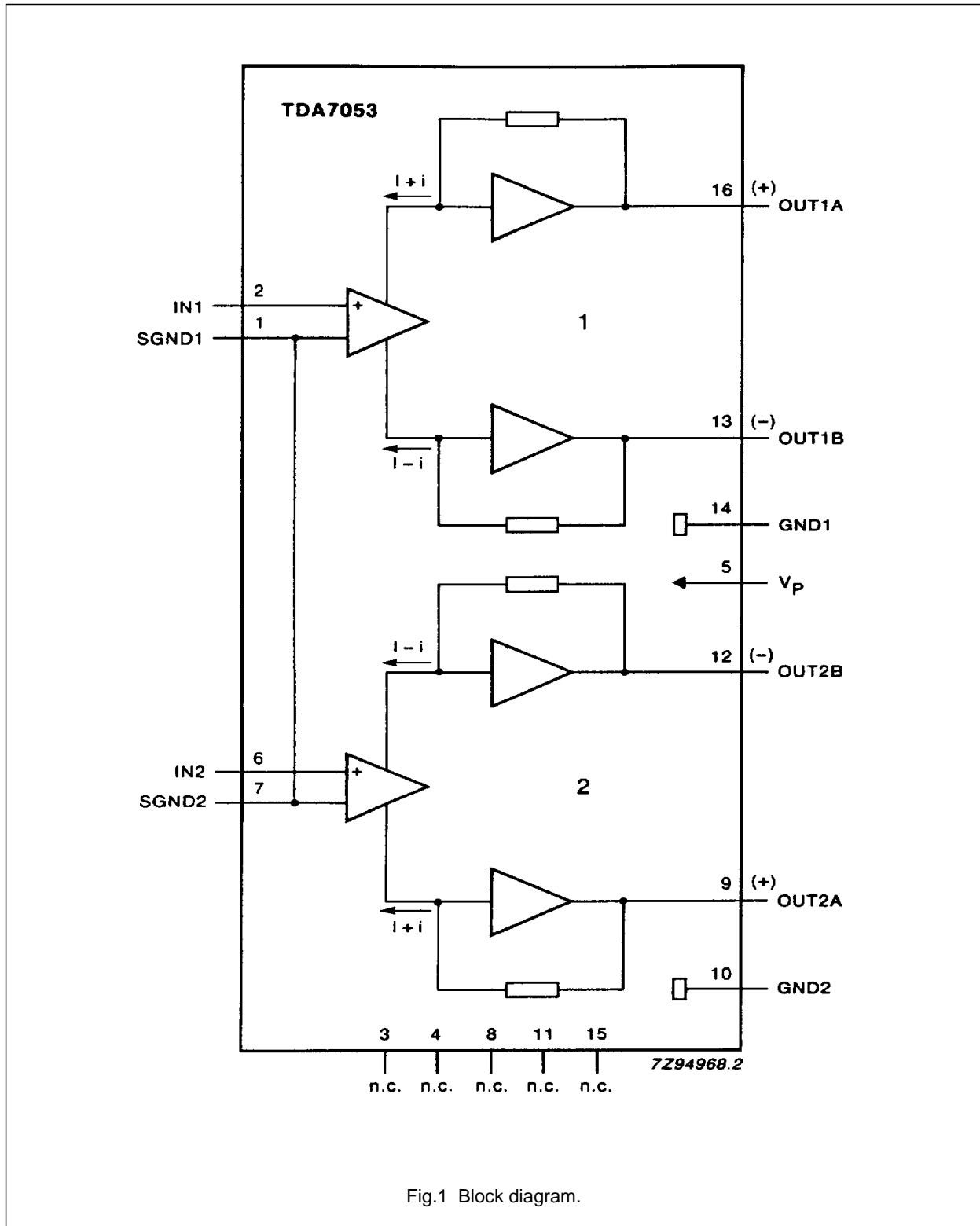

Fig.1 Block diagram.

**2 x 1 W portable/mains-fed stereo
power amplifier**

TDA7053**PINNING**

1.	SGND1	signal ground 1	9.	OUT2A	output 2 (positive)
2.	IN1	input 1	10.	GND2	power ground 2
3.	n.c.	not connected	11.	n.c.	not connected
4.	n.c.	not connected	12.	OUT2B	output 2 (negative)
5.	V _P	supply voltage	13.	OUT1B	output 1 (negative)
6.	IN2	input 2	14.	GND1	power ground 1
7.	SGND2	signal ground 2	15.	n.c.	not connected
8.	n.c.	not connected	16.	OUT1A	output 1 (positive)

Note

The information contained within the parentheses refer to the polarity of the loudspeaker terminal to which the output must be connected.

FUNCTIONAL DESCRIPTION

The TDA7053 is a stereo output amplifier, with an internal gain of 39 dB, which is primarily for use in portable audio applications but may also be used in mains-fed applications. The current trends in portable audio application design is to reduce the number of batteries which results in a reduction of output power when using conventional output stages. The TDA7053 overcomes this problem by using the Bridge-Tied-Load (BTL) principle and is capable of delivering 1.2 W into an 8 Ω load ($V_P = 6$ V). The load can be short-circuited under all input conditions.

2 x 1 W portable/mains-fed stereo power amplifier

TDA7053

RATINGS

Limiting values in accordance with the Absolute Maximum System (IEC 134)

PARAMETER	CONDITIONS	SYMBOL	MIN.	MAX.	UNIT
Supply voltage		V_P	–	18	V
Non-repetitive peak output current		I_{OSM}	–	1.5	A
Total power dissipation		P_{tot}	see Fig.2		
Crystal temperature		T_c	–	+150	°C
Storage temperature range		T_{stg}	–55	+150	°C

THERMAL RESISTANCE

From junction to ambient

 $R_{th\ j-a}$

50

K/W

Power dissipation

Assuming: $V_P = 6\text{ V}$ and $R_L = 8\ \Omega$:The maximum sinewave dissipation is 1.8 W, therefore $T_{amb(max.)} = 150 - (50 \times 1.8) = 60\text{ °C}$.

Fig.2 Power derating curve.

2 x 1 W portable/mains-fed stereo power amplifier

TDA7053

CHARACTERISTICS

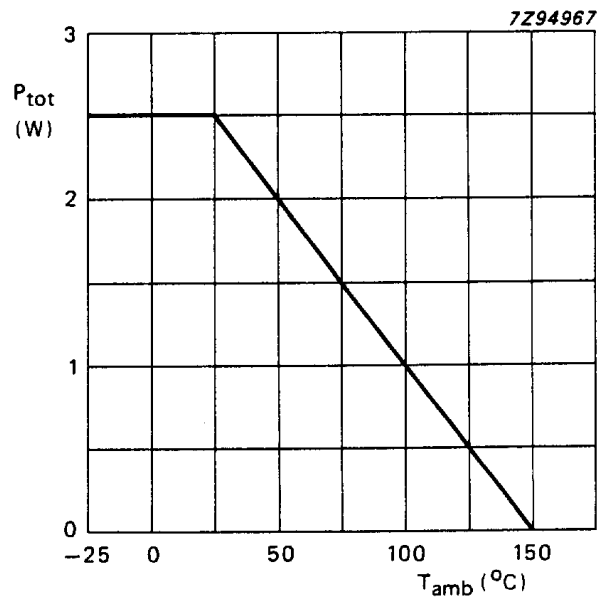
$V_P = 6\text{ V}$; $R_L = 8\ \Omega$; $T_{\text{amb}} = 25\text{ }^\circ\text{C}$; unless otherwise specified; measured from test circuit, Fig.7.

PARAMETER	CONDITIONS	SYMBOL	MIN.	TYP.	MAX.	UNIT
Supply voltage range		V_P	3	6	18	V
Total quiescent current	$R_L = \infty$; note 1	I_{tot}	–	9	16	mA
Input bias current		I_{bias}	–	100	300	nA
Supply voltage ripple rejection	note 2	SVRR	40	50	–	dB
Input impedance		Z_I	–	100	–	k Ω
DC output offset voltage	note 3	ΔV_{13-16}	–	–	100	mV
		ΔV_{12-9}	–	–	100	mV
Noise output voltage (RMS value)	note 4	$V_{\text{no(rms)}}$	–	150	300	μV
	note 5	$V_{\text{no(rms)}}$	–	60	–	μV
Output power	THD = 10%	P_O	–	1.2	–	W
Total harmonic distortion	$P_O = 0.1\text{ W}$	THD	–	0.2	1.0	%
Internal voltage gain		G_V	38	39	40	dB
Channel balance		ΔG_V	–	–	1	dB
Channel separation	note 3	α	40	–	–	dB
Frequency response		f	–	0.02 to 20	–	kHz

Notes to the characteristics

1. With a practical load the total quiescent current depends on the offset voltage.
2. Ripple rejection measured at the output with $R_S = 0\ \Omega$ and $f = 100\text{ Hz}$ to 10 kHz . The ripple voltage (200 mV) is applied to the positive supply rail.
3. $R_S = 5\text{ k}\Omega$.
4. The noise output voltage (RMS value) is measured with $R_S = 5\text{ k}\Omega$, unweighted and a bandwidth of 60 Hz to 15 kHz.
5. The noise output voltage (RMS value) is measured with $R_S = 0\ \Omega$ and $f = 500\text{ kHz}$ with 5 kHz bandwidth. If $R_L = 8\ \Omega$ and $L_L = 200\ \mu\text{H}$ the noise output current is only 100 nA.

2 x 1 W portable/mains-fed stereo
power amplifier

TDA7053

APPLICATION INFORMATION

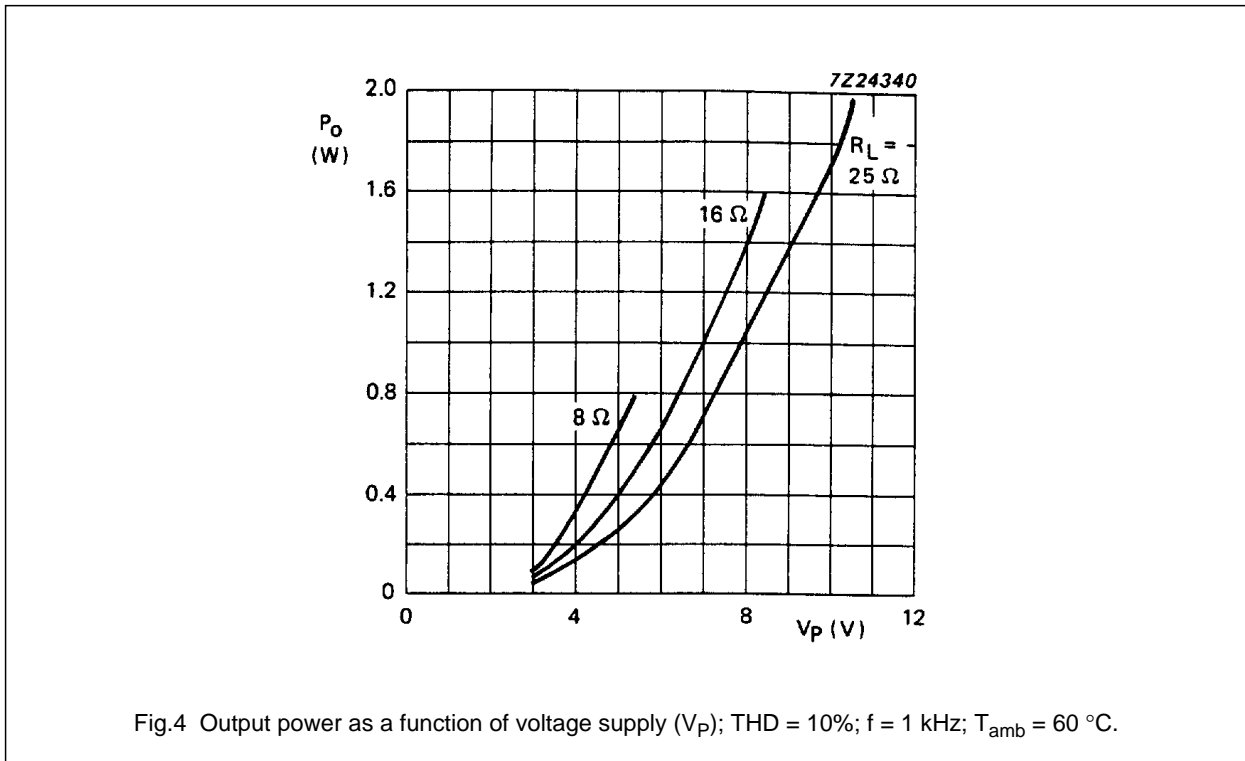
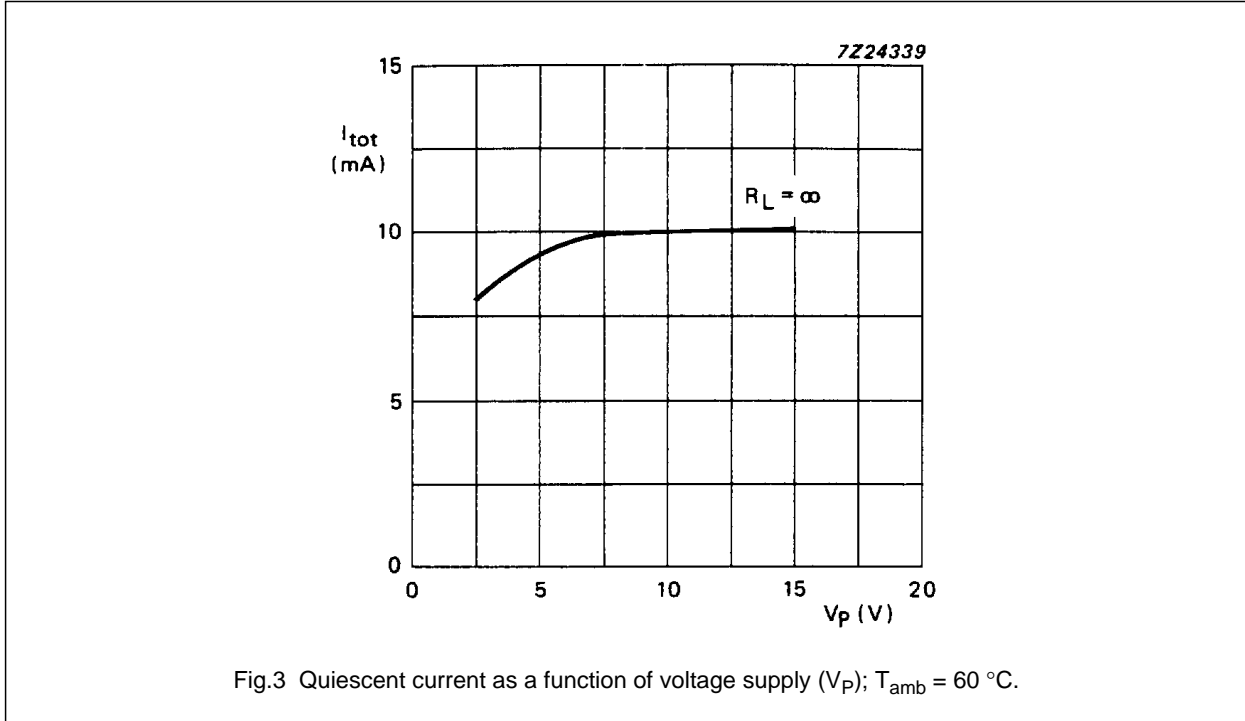

2 x 1 W portable/mains-fed stereo
power amplifier

TDA7053

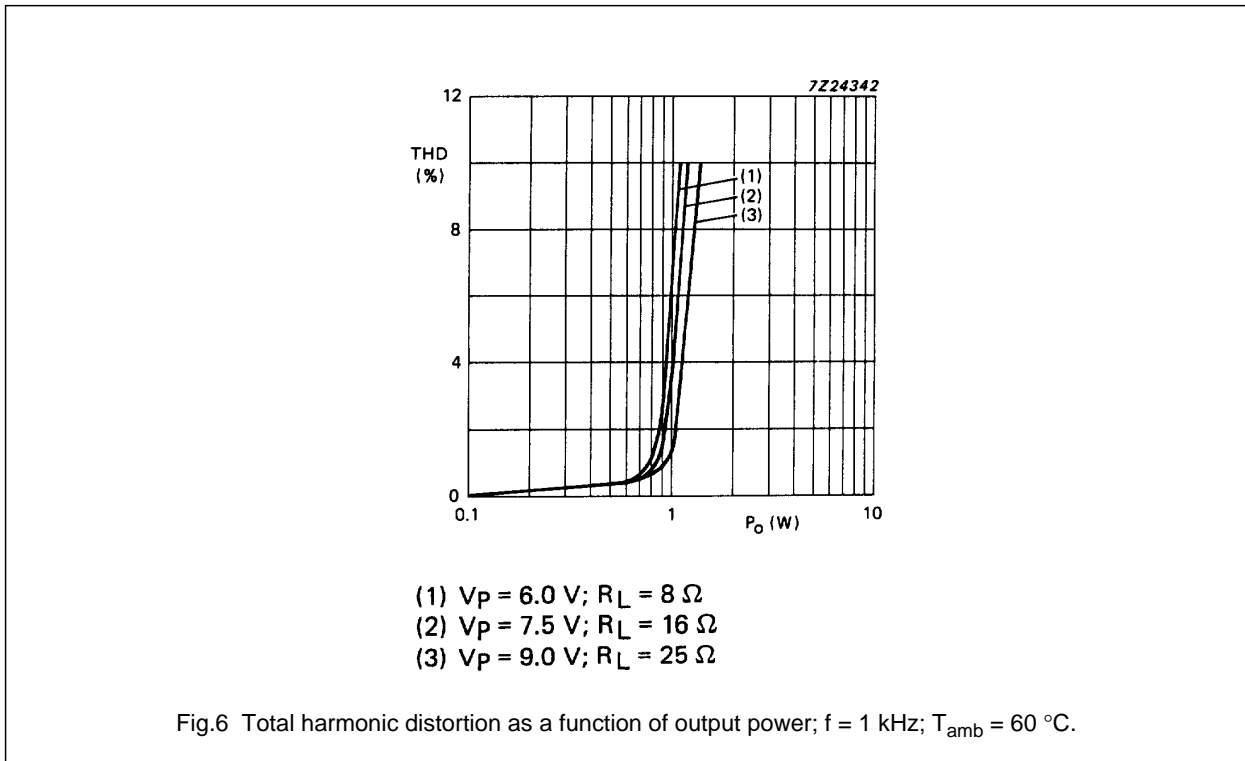
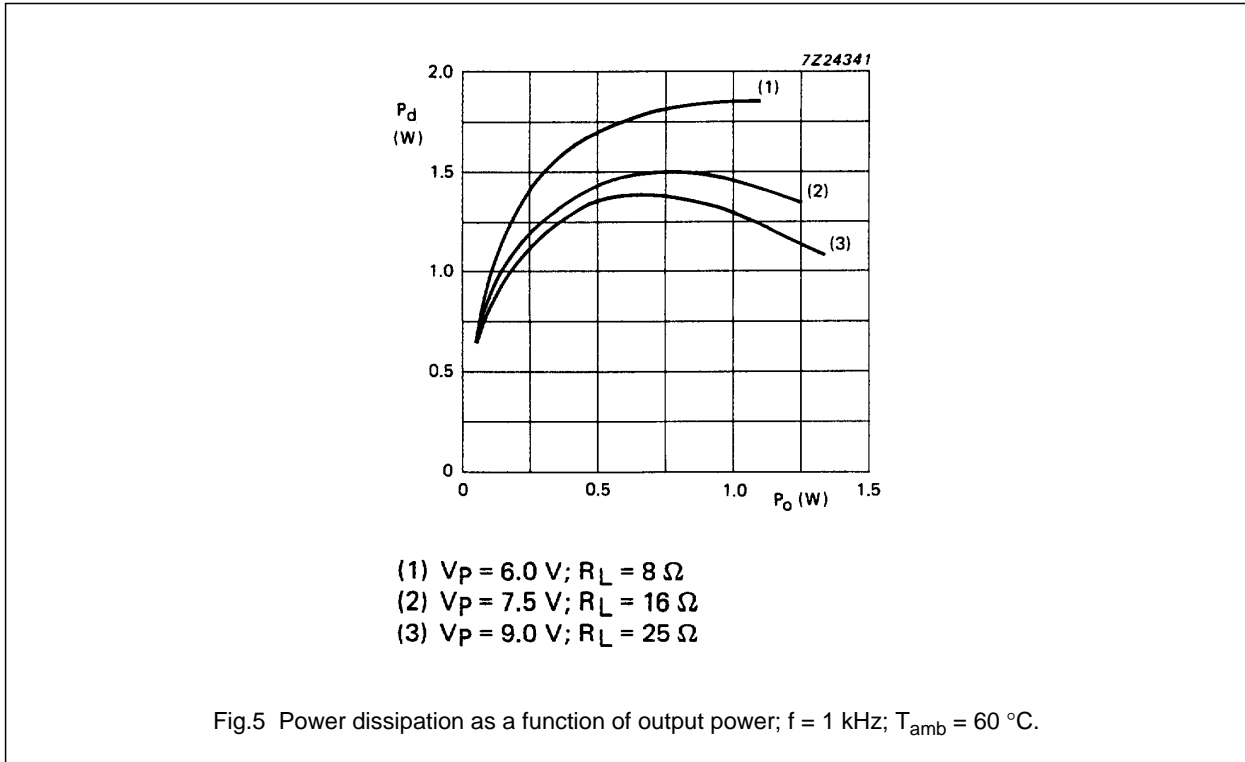

2 x 1 W portable/mains-fed stereo
power amplifier

TDA7053

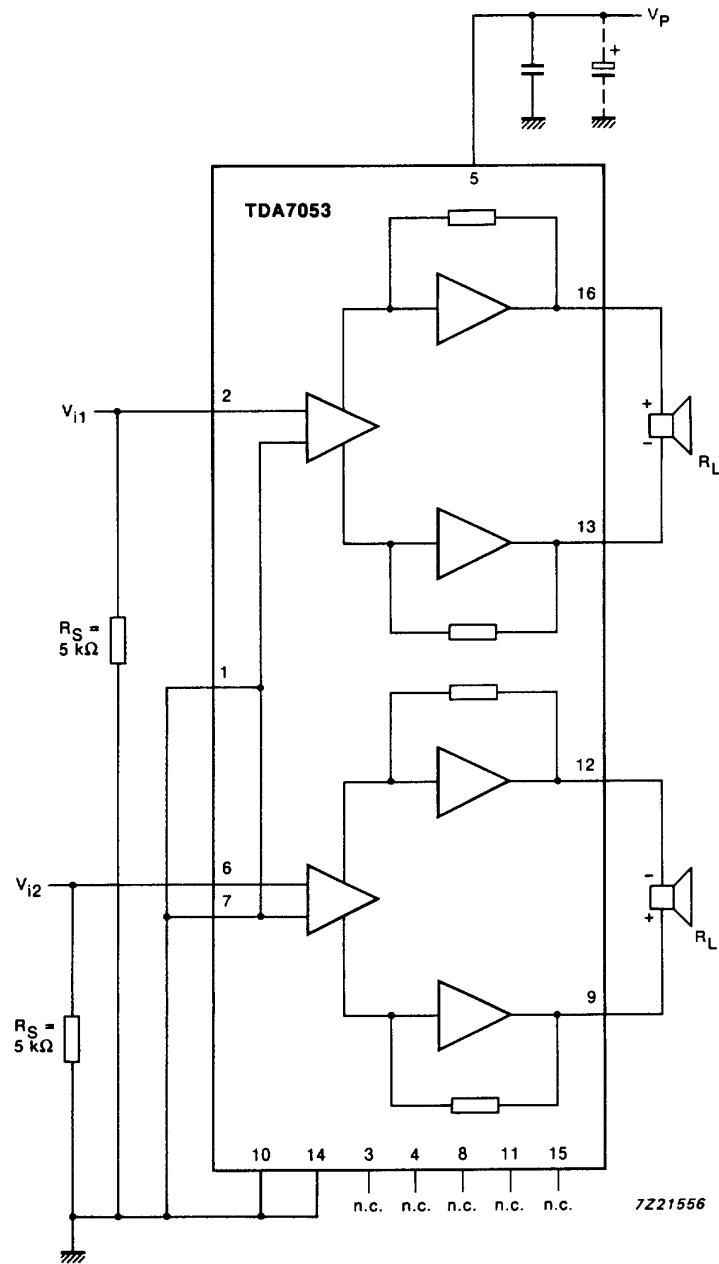

Fig.7 Test and application circuit diagram.

2 x 1 W portable/mains-fed stereo
power amplifier

TDA7053

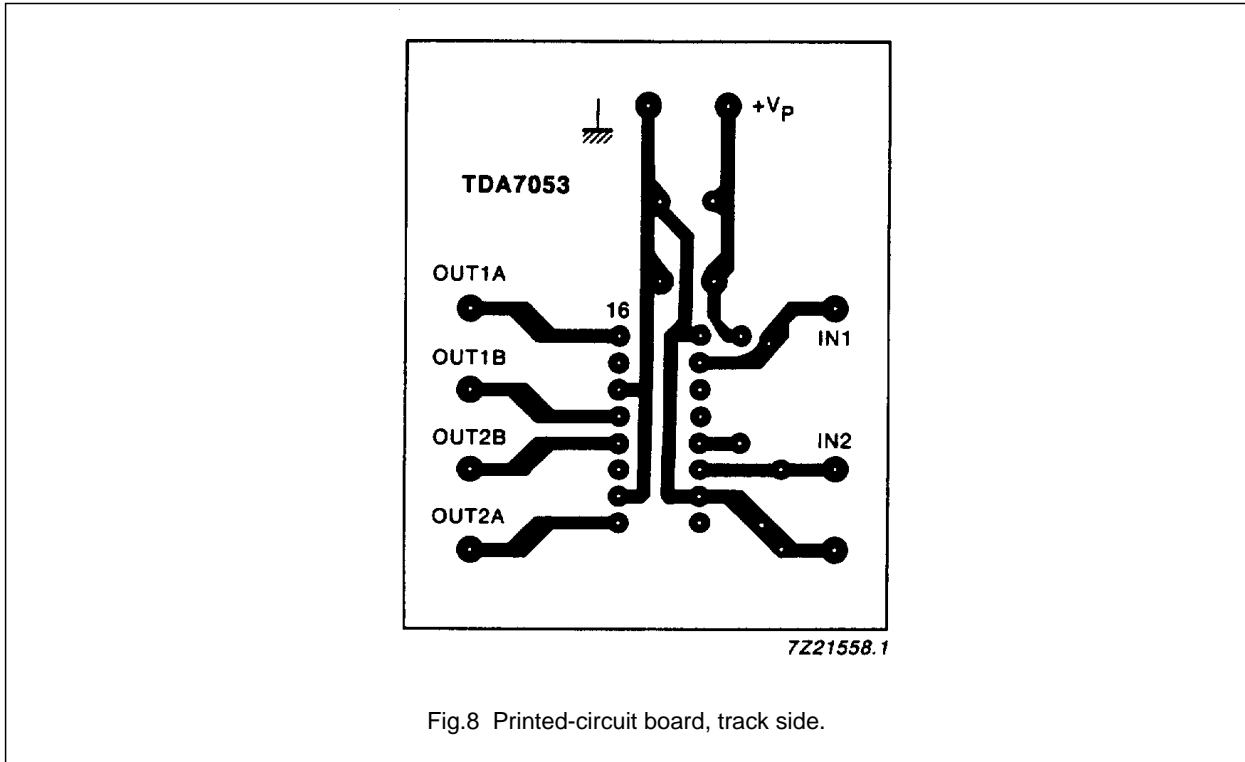

Fig.8 Printed-circuit board, track side.

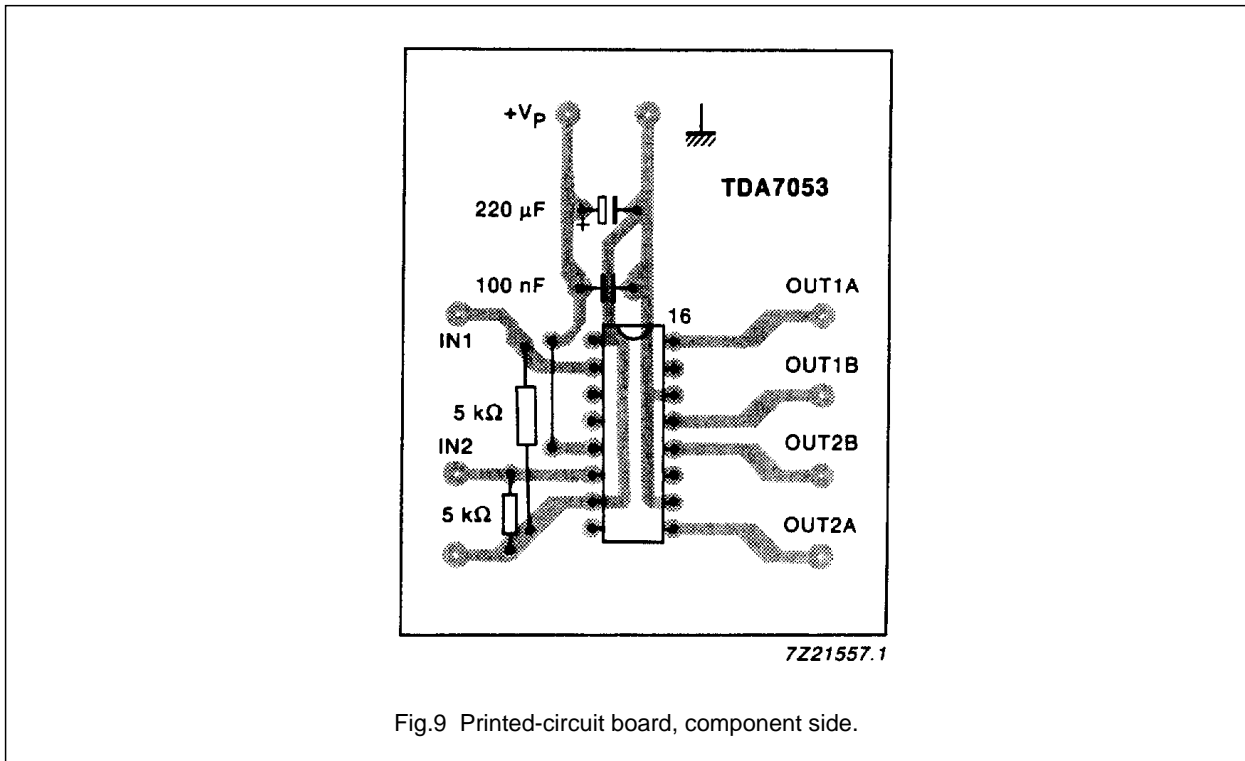

Fig.9 Printed-circuit board, component side.

2 x 1 W portable/mains-fed stereo
power amplifier

TDA7053

PACKAGE OUTLINE

DIP16: plastic dual in-line package; 16 leads (300 mil); long body

SOT38-1

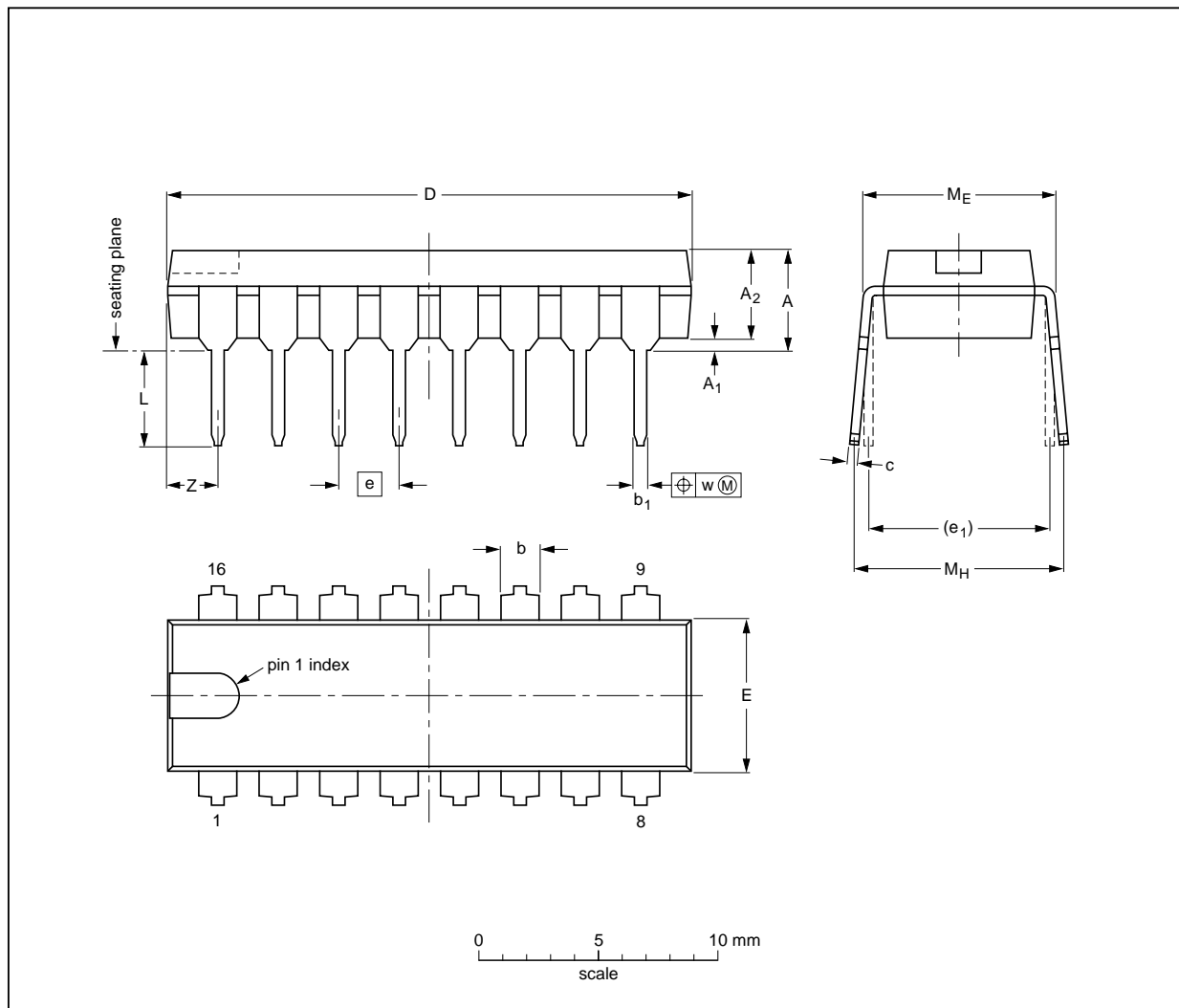

DIMENSIONS (inch dimensions are derived from the original mm dimensions)

UNIT	A max.	A ₁ min.	A ₂ max.	b	b ₁	c	D ⁽¹⁾	E ⁽¹⁾	e	e ₁	L	M _E	M _H	w	Z ⁽¹⁾ max.
mm	4.7	0.51	3.7	1.40 1.14	0.53 0.38	0.32 0.23	21.8 21.4	6.48 6.20	2.54	7.62	3.9 3.4	8.25 7.80	9.5 8.3	0.254	2.2
inches	0.19	0.020	0.15	0.055 0.045	0.021 0.015	0.013 0.009	0.86 0.84	0.26 0.24	0.10	0.30	0.15 0.13	0.32 0.31	0.37 0.33	0.01	0.087

Note

1. Plastic or metal protrusions of 0.25 mm maximum per side are not included.

OUTLINE VERSION	REFERENCES			EUROPEAN PROJECTION	ISSUE DATE
	IEC	JEDEC	EIAJ		
SOT38-1	050G09	MO-001AE			92-10-02- 95-01-19

2 x 1 W portable/mains-fed stereo power amplifier

TDA7053

SOLDERING

Introduction

There is no soldering method that is ideal for all IC packages. Wave soldering is often preferred when through-hole and surface mounted components are mixed on one printed-circuit board. However, wave soldering is not always suitable for surface mounted ICs, or for printed-circuits with high population densities. In these situations reflow soldering is often used.

This text gives a very brief insight to a complex technology. A more in-depth account of soldering ICs can be found in our "IC Package Databook" (order code 9398 652 90011).

Soldering by dipping or by wave

The maximum permissible temperature of the solder is 260 °C; solder at this temperature must not be in contact with the joint for more than 5 seconds. The total contact time of successive solder waves must not exceed 5 seconds.

The device may be mounted up to the seating plane, but the temperature of the plastic body must not exceed the specified maximum storage temperature ($T_{stg\ max}$). If the printed-circuit board has been pre-heated, forced cooling may be necessary immediately after soldering to keep the temperature within the permissible limit.

Repairing soldered joints

Apply a low voltage soldering iron (less than 24 V) to the lead(s) of the package, below the seating plane or not more than 2 mm above it. If the temperature of the soldering iron bit is less than 300 °C it may remain in contact for up to 10 seconds. If the bit temperature is between 300 and 400 °C, contact may be up to 5 seconds.

DEFINITIONS

Data sheet status	
Objective specification	This data sheet contains target or goal specifications for product development.
Preliminary specification	This data sheet contains preliminary data; supplementary data may be published later.
Product specification	This data sheet contains final product specifications.
Limiting values	
Limiting values given are in accordance with the Absolute Maximum Rating System (IEC 134). Stress above one or more of the limiting values may cause permanent damage to the device. These are stress ratings only and operation of the device at these or at any other conditions above those given in the Characteristics sections of the specification is not implied. Exposure to limiting values for extended periods may affect device reliability.	
Application information	
Where application information is given, it is advisory and does not form part of the specification.	

LIFE SUPPORT APPLICATIONS

These products are not designed for use in life support appliances, devices, or systems where malfunction of these products can reasonably be expected to result in personal injury. Philips customers using or selling these products for use in such applications do so at their own risk and agree to fully indemnify Philips for any damages resulting from such improper use or sale.